

DEVELOPMENT OF MYCOBACTERIOPHAGE L5
AS A
MARKER FOR MUTATION INDUCTION IN
MYCOBACTERIA

Belinda Lea Spillings

A dissertation submitted to the Faculty of Science, University of the Witwatersrand, in
fulfilment of the requirements for the degree of Master of Science

Johannesburg, 2005

DECLARATION

I declare that this dissertation is my own, unaided work. It is being submitted for the Degree of Master of Science in the University of Witwatersrand, Johannesburg. It has not been submitted before any degree or examination in any other University.

(Signature of Candidate)

_____ day of _____ 2006

ABSTRACT

Due to the paucity of sensitive mutation markers available for studying mycobacterial species it was decided to explore the suitability of mycobacteriophage L5 as an analogous mutation detection system to phage Lambda in *E. coli*. The system relies on the detection of an increased production of clear plaque mutants (CPM) arising from turbid plaques, in response to DNA damage. A number of L5 phage experimental tools were developed and optimized, including a lysogen-based CPM confirmation assay. The mutant induction system was applied to wild type *M. smegmatis* mc²155 and its *recA* mutant, *dinP* mutant as well as an *M. smegmatis*(L5) lysogen. The lysogen system proved to be insensitive with respect to mutant induction since elevated CPM frequencies could not be detected. Interestingly, the wild type *M. smegmatis* mc²155 system demonstrated slightly elevated CPM frequencies in response to transfection of untreated L5 on UV irradiated host cells. This result suggests that a host SOS mutagenic system is able to act on normal, undamaged DNA bases. The involvement of the SOS response in untargeted mutagenesis was confirmed by the abrogation of increased CPM frequency, in an *M. smegmatis recA* mutant. This data supports suggestions that RecA is responsible for the control of the SOS response. The *M. smegmatis dinP* mutant system showed a decrease in CPM frequency which supports evidence that this gene does have mutator polymerase activity, as is in seen *E. coli dinP* homologues.

KEYWORDS: Untargeted mutagenesis; Mycobacteriophage L5; Mutation Marker; DinP/RecA Mutants

ACKNOWLEDGMENTS

I would like to thank Prof Valerie Mizrahi for supplying the *Mycobacterium smegmatis* mc²155 strain; Dr Bhavna Gordhan for her invaluable assistance in the UV assays; Dr Edith Machowski for supplying the *M. smegmatis RecA* mutant and her help with the *attP/B* primer design; Digby Warner for supplying me with the *M. smegmatis DinP* mutant; Dr Pedulla for supplying the initial Mycobacteriophage L5 stock and her advice on creating high-titre stocks; Prof. Dabbs for his helpful suggestions for working with the lysogen.

To my lab partners, both past and present, and my supervisor – Thank You.

CONTENTS	Page
DECLARATION.....	ii
ABSTRACT.....	iii
ACKNOWLEDGMENTS.....	iv
LIST OF FIGURES.....	vii
LIST OF TABLES.....	viii
LIST OF ABBREVIATIONS.....	ix
TABLE OF STRAINS AND OLIGONUCLEOTIDES.....	x
CHAPTER ONE – INTRODUCTION	
1.1 General Introduction.....	1
1.2 Literature Review.....	2
1.3 Aims and Research Hypothesis.....	16
CHAPTER TWO – OPTIMIZATION OF PHAGE TECHNIQUES	
2.1 Introduction.....	17
2.2 Aims and Objectives.....	21
2.3 Methods.....	22
2.4 Results.....	26
2.5 Discussion.....	31
2.6 Conclusion.....	34
CHAPTER THREE – ULTRAVIOLET DOSE EXPERIMENTS	
3.1 Introduction.....	35
3.2 Aims and Objectives.....	37
3.3 Methods.....	38
3.4 Results.....	39
3.5 Discussion and Conclusion.....	40

CHAPTER FOUR – MUTATION INDUCTION ASSAYS

4.1	Introduction.....	44
4.2	Aims and Objectives.....	47
4.3	Methods.....	47
4.4	Results.....	50
4.5	Discussion	54
4.6	Conclusion.....	57

CHAPTER FIVE – CONCLUDING REMARKS

Concluding Remarks.....	58
-------------------------	----

REFERENCES.....	62
------------------------	-----------

APPENDIX A

List of Chemicals and Suppliers	73
---------------------------------------	----

APPENDIX B

General Media and Buffers	74
---------------------------------	----

LIST OF FIGURES

Figure 1:	The Bacteriophage Marker System	11
Figure 2:	Electron micrograph of Mycobacteriophage L5, Dr B. Duda, University of Pittsburgh. (http://www.asmus.org/division/m/foto/L5Mic.html) ...	12
Figure 3a:	Diagrammatic representation of phage lysogeny	15
Figure 3b:	Diagrammatic representation of phage lysis	15
Figure 4a:	Isolated Phage L5 DNA, 0.8% TAE agarose gel.....	27
Figure 4a:	Restriction products of the mycobacteriophage L5 sample, 0.7% TAE agarose gel.....	27
Figure 5:	Schematic representation of the PCR-based confirmation technique used on <i>M. smegmatis</i> mc ² 155 wild type and lysogen strains.....	30
Figure 6:	Confirmation of the status of the <i>M. smegmatis</i> mc ² 155 (L5) Lysogen, 1% TAE agarose gel.....	31
Figure 7:	Mycobacteriophage L5 clear plaque mutants visualised against a background of wild type turbid plaques.....	32
Figure 8:	Formation of the toxic and mutagenic DNA lesion, the pyrimidine dimer. This schematic diagram shows the formation of a thymine dimer and its photoreactivation by photolyase (Sinha and Häder, 2002).....	37
Figure 9:	UV dose experiments showing the effect of UV irradiation on <i>M. smegmatis</i> mc ² 155 wild type, L5 Lysogen, <i>recA</i> mutant and <i>dinP</i> mutant.....	41
Figure 10:	The effect of UV-irradiation on mycobacteriophage L5 survival	42
Figure 11:	Schematic outline of the DNA damaging experiments for mutation induction	49
Figure 12:	Mutant induction assay for wild type <i>M. smegmatis</i> mc ² 155	50
Figure 13:	Mutant induction assay for <i>M. smegmatis recA</i> Mutant	52
Figure 14:	Mutant induction assay for <i>M. smegmatis dinP</i> Mutant	52
Figure 15:	Mutant Induction in the L5 Lysogen after Increasing UV Irradiation	54

LIST OF TABLES

Table 1:	Presence of homologous genes involved in DNA repair systems present in <i>E. coli</i> and <i>B. subtilis</i> compared to <i>M. tuberculosis</i> through nucleotide and protein sequence alignments. (Adapted from Mizrahi and Andersen, 1998; Boshoff <i>et al.</i> , 2003; Tomkins <i>et al.</i> , 2003)	4
Table 2:	Average phage titres of samples removed from glycerol and cesium chloride gradients after ultra-centrifugation	26
Table 3:	Table of expected L5 digest fragment lengths and actual fragment lengths in bp	28
Table 4:	Inactivation of mycobacteriophage L5 by various concentrations of FAS.....	29
Table 5:	Primer pairing and expected amplicon yields with regards to template DNA used	30

LIST OF ABBREVIATIONS

CPM	Clear Plaque Mutant
FAS	Ferrous Ammonium Sulphate
L5	Mycobacteriophage L5
MOI	Multiplicity of Infection (Ratio of Phage to Host Cells)
NO·	Nitric oxide
Phage	Bacteriophage
ROI	Reactive oxygen intermediates
TB	Tuberculosis and Tubercle Bacillus
<i>vir</i> mutant	Virulent phage mutant
WHO	World Health Organisation
[]	Concentration

TABLE OF STRAINS & OLIGONUCLEOTIDES

Designated Name		Source
Host and Phage Strains:		
<i>M. smegmatis</i> mc ² 155	Wild type strain	Prof V. Mizrahi, NHLS, University of the Witwatersrand
<i>M. smegmatis</i> DinP Mutant	Wild type strain that carries a DinP ⁻ mutation	Digby Warner, NHLS, University of the Witwatersrand
<i>M. smegmatis</i> RecA Mutant	Wild type strain carrying	Dr. Edith Machowski, NHLS, University of the Witwatersrand
Mycobacteriophage L5	Wild type strain	Dr M. Pedulla
Oligonucleotides:		
MSFor	5' ACCTTGTGCTCCTTGATGC	
MSREv	5' ACGTGGCGGTCCCTACCG	
L5For	5' CTTGGATCCTCCCGCTGCGC	
L5Rev	5' AATTCTTGCAGACCCCTGGA	

CHAPTER ONE – INTRODUCTION AND LITERATURE REVIEW

1.1 INTRODUCTION:

The 7th World Health Organization (WHO) report on global tuberculosis (TB) control has been released, stating that the global incidence rate of TB is growing at a rate of 0.4% per annum. There are approximately three million deaths per year due to this disease. Of major concern is that the disease has become increasingly prevalent in Sub-Saharan Africa and India. The 2005 WHO TB Fact Sheet states that someone in the world is newly infected with the TB bacillus every second. Approximately one third of the world population is currently infected with TB and of these infected individuals, 5 – 10% will become sick or infectious at some stage in their life. TB is one the most prevalent diseases worldwide, but leprosy is the second most common mycobacterial disease, where approximately 755 000 new cases were detected in 2001 (WHO, 2003). There is no doubt that mycobacteria pose a huge disease issue in current day health.

A study carried out in 2000 by Corbett *et al.* estimated that of the 1.8 million TB deaths recorded for that year, 12% of these were attributable to HIV. Patients that are immuno-compromised by HIV are at a much higher risk of harbouring an active TB infection. TB infection has two distinct phases, initial primary infection, characterised by the establishment of localized pulmonary infection, followed by a dormancy phase where the disease or infection remains unapparent. A second outburst occurs when the patient is immuno-compromised or when pulmonary infection is renewed (Madigan *et al.*, 1997). Resistance to many conventional drugs increases the difficulty of treating this disease and rates of multi-drug resistant TB are rising in some countries, especially the former Soviet Union (WHO, 2005). The recent completion of the genome sequence for *M. tuberculosis* (Cole *et al.*, 1998) will enable the development of new drugs, as well as the improved use of those which are currently available.

1.2 LITERATURE REVIEW:

Genome Sequence and Genetic Variation in *M. tuberculosis*

Mycobacterium tuberculosis, the causative agent of TB, is a gram positive, aerobic, slow growing bacteria, with an additional protective layer that is rich in lipids, glycolipids and polysaccharides, contributing to its acid fast nature (Madigan *et al.*, 1997). During infection the tubercule bacillus exhibits a generation time of approximately 24 hours, in both animals and synthetic media. The laboratory strain H37Rv genome has been sequenced (Cole *et al.*, 1998) and found to be 4.4Mbp, with approximately 3900 open reading frames and a G+C content of 65.6%. The availability of sequence information has allowed for more research into the level of genetic variation in *M. tuberculosis* and related species.

Streevastan *et al.* (1997) compared gene polymorphism between a large group of independent *M. tuberculosis* isolates and showed that the genome is either evolutionarily 'young' or unusually resistant to change. Even though *M. tuberculosis* has been deemed to be evolutionarily relatively young, and as a consequence has limited genetic polymorphisms (Streevatsen *et al.*, 1997) there are still significant amounts of genetic variation to be found when comparing strains that have been fully sequenced (Fleischmann *et al.*, 2002). A comparison of strains H37Rv (laboratory strain) and CDC1551 (clinical strain) has shown evidence of high levels of long sequence polymorphisms as well as high levels of single nucleotide polymorphisms (Fleischmann *et al.*, 2002). It is interesting to note that the majority of sequence polymorphisms occur in regions that encode for members of the PE/PPE protein family - an acidic; glycine rich family of proteins that may be surface proteins acting as antigens for host immunity (Fleischmann *et al.*, 2002).

The nucleotide sequences of the PE and PPE protein families are repeated continuously throughout the entire genome of *M. tuberculosis* (Cole *et al.*, 1998; Boshoff *et al.*, 2001). Similarly, the IS6110/IS986 insertion sequence is carried at a copy number of 8 to 15 copies and is situated anywhere within the genome, thus its presence has been shown to

be both species as well as strain dependant (van Embden *et al.*, 1993; Poulet *et al.*, 1995; Fleischmann *et al.*, 2002). Insertion sequences, most of which exist as clusters, occur mainly in intergenic regions implying that the presence of insertional ‘hot spots’ may prevent inactivation of functional genes. Many of these ‘hot spot’ regions are defined by direct repeats separated by spacer sequences, both of which are variable in length and copy number according to strain, allowing for the development of fingerprinting techniques for strain typing (Poulet *et al.*, 1995; Van Soolingen *et al.*, 1995; van Embden *et al.*, 2000). It has been suggested that the acquisition of insertion sequences and as well as deletions could lead to increased levels of pathogenesis (Fleischmann *et al.*, 2002) however it has been shown that the genome of *M. tuberculosis* encodes a high level of chromosomally-encoded drug resistance, allowing the organism to adapt to drug pressure. This drug resistance may in turn, be caused by small deletions and point mutations within the resistance encoding regions which may lead to multidrug resistant forms of *M. tuberculosis* (Boshoff *et al.*, 2001).

Potential Sources of DNA Damage

Many of the mutations resulting in the emergence of the drug resistant strains may have arisen as a result of DNA damage. The source of the damage may be from the host environment or it may have an intracellular origin and therefore it may have arisen from within the bacterial cell. Intracellular sources of DNA damage are apparent during anaerobic respiration, which occurs in the chronic phase of *M. tuberculosis* infections (Wayne and Hayes, 1998), when nitrate reductase activity is elevated (Webber *et al.*, 2000), leading to an increased production of the reactive metabolic byproduct nitric oxide (NO•). Nitric oxide in turn may react with superoxide radicals to form powerful DNA damaging agents (Wiid *et al.*, 2002; Durbach *et al.*, 2003).

Further intracellular DNA damage-mediated mutations could potentially occur through the action of error-prone DNA polymerases and mutases such as DNA Pol IV that typically act at the site of DNA damage. In *E. coli*, DNA Pol IV may insert mutations at sites of DNA damage (Tomkins *et al.*, 2003). The extent of this action is however

unclear in *M. tuberculosis* even though homologues of these genes seem to be present (Mizrahi and Andersen, 1998; Tomkins *et al.*, 2003, See Table 1, below).

Table 1: Presence of homologous genes involved in DNA repair systems present in *E. coli* and *B. subtilis* compared to *M. tuberculosis* through nucleotide and protein sequence alignments. (Adapted from Mizrahi and Andersen, 1998; Boshoff *et al.*, 2003; Tomkins *et al.*, 2003)

	<u>Genes involved in DNA Repair</u>	<u>Repair System</u>	<u>Homologues Present in <i>M. tuberculosis</i>?</u>
Long Patch Mismatch Repair	<i>mutS, mutL, mutH, dam</i>	Targets repair to daughter strand of DNA	No
Short Patch Mismatch Repair	<i>Dcm, vsr, mutY, uvrABC</i>	Short patch mismatch repair, A•G and A•C mismatches repaired by adenine excision, uvrABC excinuclease excises mismatch from either strand. Lacks strand specificity leading to potential mutation fixation	Yes
Base Excision Repair	<i>alkA, nei, nth, fpg, mutY, mutT</i> . Genes encoding Pol II, Pol IV and DNA ligases	Correction of alkylation and oxidative damage of purines and pyrimidines through glycosylase type enzymes.	Yes
Nucleotide Excision Repair	Uvr ABC genes, <i>uvrD, polA, mfd, mutS, mutL</i>	Mfd assists uvrABC to bind to damaged DNA in order to initiate excision-repair system. Lacks <i>mutS</i> and <i>mutL</i> , therefore reduced efficiency of transcription-coupled nucleotide excision repair.	Yes, except <i>mutS</i> and <i>mutL</i>
Reversal of DNA Damage	<i>phrB (phr), spl, ogt</i>	Reversal of UV-induced damage, repair of O ⁶ MeG and O ⁴ MeT formation	Only <i>Ogt</i> for the reversal of alkylation damage been identified
Recombinational Repair	<i>recBCD, recJ</i>	Ability to repair double stranded breakage, RecF recombinational repair pathway	Yes
Damage Inducible Repair and Mutagenesis	<i>recA, lexA, alkA, ogt, polB, umuDC, dnaE2, dinP/B</i> , and associated enzyme cascades.	Series of repair and mutagenic activities that occur in response to LexA cleavage by RecA. <i>dnaE2</i> has recently been found to be involved with UV-induced mutagenesis (Boshoff <i>et al.</i> , 2003). Pol IV, encoded by <i>dinB</i> , has been found to play a role in non-selected mutations in <i>E. coli</i> (McKenzie and Rosenberg, 2001; Tomkins <i>et al.</i> , 2003).	Almost all present except, <i>umuD</i> (Brooks <i>et al.</i> , 2001) and <i>polB</i>

Sources of DNA damage not only arise within the cell, but may also be brought about extracellularly. During the course of an infection the tubercle bacillus is subjected to many host environmental challenges. The bacterium has adapted in order to cope with oxygen competition in the lungs as well as low pH and anaerobic conditions in granulomas (Cole *et al.*, 1998, Boshoff *et al.*, 2001). Macrophage activity increases levels of nitrosative stress through the production of NO[•], which in turn produces nitrous anhydride when reacting with O₂. Nitrous anhydride is capable of nitrosating amines and amides, which when metabolically activated can potentially form powerful DNA alkylating agents which primarily cause G to A transitions (Taverna and Sedgwick, 1996; Durbach *et al.*, 2003). Phagocytic host cells also produce reactive oxygen intermediates (ROI's) which may result in oxidative DNA damage (Mizrahi and Andersen, 1998; Durbach *et al.*, 2003).

DNA Repair Mechanisms in *M. tuberculosis*

Due to the potentially high levels of DNA damage that *M. tuberculosis* could sustain from its host environment, it would be advantageous for the organism to possess functional detoxification systems as a first line of defense. However, it is interesting to note that the organism lacks functional OxyR and SoxRS regulons, involved in detoxification of oxidative stress, but does have superoxide dismutase and thioredoxin systems (Boshoff *et al.*, 2001). The presence of a limited 'first-line of defense' system suggests that *M. tuberculosis* may require a comprehensive DNA repair capacity. Evidence from the genome sequence suggests that *M. tuberculosis* has the capacity to deal with most types of the DNA damage (Mizrahi and Andersen, 1998). A summary of some of the genes involved is shown in Table 1, on the previous page.

Based on this genome survey (Mizrahi and Andersen, 1998), it is clear that *M. tuberculosis* has the capacity to repair much DNA damage, although it is not necessarily clear that the genome of *M. tuberculosis* even sustains damage during the course of an infection. Durbach *et al.* (2003), constructed an $\Delta adl-ogt$ mutant of *M. tuberculosis* that lacked the region of *ogt* which contains the alkyl-acceptor site and 'knocked out' the methyl-acceptor site on *adl*. In addition to this, the AlkA-motif was also disrupted. This

mutant displayed reduced survival *in vitro* but very similar levels of survival to wild type strains when placed *in vivo* in a mouse model (Durbach *et al.*, 2003) which suggests that DNA damage via alkylation may not permeate to the level of the genome at detectable levels.

Interestingly, Boshoff *et al.* (2003) recorded a six fold increase of the expression of *dnaE2* in *M. tuberculosis* cultures obtained *in vivo*, from their murine model. *M. tuberculosis* carries two copies of the *dnaE* polymerase, designated *dnaE1* and *dnaE2*. The upregulation of *dnaE2* has been directly linked to the organisms' response to DNA damage through the use of ultra violet irradiation, mitomycin C or hydrogen peroxide *in vitro* (Boshoff *et al.*, 2003). This data suggests that DNA damage does indeed permeate down to the genome level and that *dnaE2* may potentially play a role in DNA damage-induced mutagenesis (Boshoff *et al.*, 2003).

DNA Repair Mechanisms in *M. tuberculosis*: Potential for DNA-damage-induced Mutagenesis

It is evident that *M. tuberculosis* possesses DNA repair systems, which act in response to the presence of DNA damage (Boshoff *et al.*, 2003; Tomkins *et al.*, 2003; McKenzie and Rosenberg, 2001; Brooks *et al.*, 2001). Further, *M. tuberculosis*' ability to engage in DNA-damage induced mutagenesis has been suggested by the presence of *dinB/umuC* homologues (McKenzie and Rosenberg, 2001; Brooks *et al.*, 2001) that have potential error prone polymerase activity (Radman, 1999; Tomkins *et al.*, 2003). Boshoff *et al.* (2003) determined that many genes that were DNA-damage inducible in *E. coli* were in fact not inducible in *M. tuberculosis* and similarly, some genes (e.g. *alkA*, *ogt*, *radA*, *lhr*, *dnaB*, *sbcD*) were uniquely damage-induced in *M. tuberculosis*. Further, it is suggested that *dnaE2* may encode polymerase activity responsible for damage-induced mutagenesis; such that *dnaE2*-mediated mutagenesis may play a role in the acquisition of drug resistance in *M. tuberculosis* (Boshoff *et al.*, 2003).

The SOS response which is generally upregulated during harsh host environmental conditions (Aertsen *et al.*, 2004), stationary phase (Yelser *et al.*, 2002), under DNA damaging conditions (Madigan *et al.*, 1997) and indirectly through nutrient limitation (McKenzie *et al.*, 2000), has been shown to lead to increased frequencies of targeted¹ and non-targeted mutagenesis² (Brooks *et al.*, 2001; Brotcorne-Lannoeye and Maenhaut-Michel, 1986; Friedberg *et al.*, 2000; Kim *et al.*, 1997). Durbach *et al.*, (1997) found that *M. smegmatis*, *M. tuberculosis* and *M. leprae* all encode a homologue of the *lexA* repressor, which functions to regulate the SOS response similar to that in *B. subtilis*. Radman (1999) suggests that during times of cell stress, mutations are selected for since they may result in useful diversity, whereas under conditions of normal growth the mutation rate has evolved to be as low as possible. The balance between error-avoidance, error-correction and error-fixation determines the optimal mutation rate and during adaptive mutation inactivation of ‘antimutator’ alleles or activation of mutators would serve to increase these mutational levels (Taddei *et al.*, 1997).

This evidence of a potential SOS response (Durbach *et al.*, 2003) as well as the presence of potential DNA mutases (Boshoff *et al.*, 2003) strengthens the possibility of a DNA-damage induced mutagenesis system which ultimately could lead to increased genetic variation as well as acquired drug resistance. The absence of a functional mismatch repair system (see Table 1, page 4) could provide a mechanism for mutation fixation following the activity of the DNA-damage induced mutagenesis systems, thereby ensuring the carry through of genetic variation (Harris *et al.*, 1997).

Forward Mutation Assays for *M. tuberculosis*

In order to investigate these mutational processes, systems for directly measuring the rate of mutation need to be developed. The use of forward mutation assays such as the *rrs/rpsL* and *rpoB* systems, which provide the cell with streptomycin and rifampicin

¹ Definition: Targeted Mutagenesis – mutations originating from direct damage to the DNA via a non-cellular system, e.g. Ultra violet irradiation, Mitomycin C, Hydrogen Peroxide. This damage results in mutation fixation through mechanisms such as trans-lesion synthesis.

² Definition: Non-Targeted Mutagenesis – untargeted mutagenesis, mutations that arise on undamaged DNA templates due to cellular mechanisms, generally due to low fidelity DNA polymerases (e.g. Pol IV) and mutases.

resistant phenotypes respectively, have been widely utilized (Spindola de Miranda *et al.*, 2001). Mutations within the *rpoB* region result in changes of the targeted binding site of rifampicin to the β -subunit of the bacterial RNA polymerase, thereby conferring rifampicin resistance (Bobadilla-del-Valle *et al.*, 2001). Streptomycin resistance is gained due to mutations in either the 16S rRNA gene (*rrs*) or the gene encoding the ribosomal protein S12 (*rpsL*) (Karunakaran and Davies, 2000).

Rifampicin and streptomycin resistances are regarded as excellent markers for *rpoB* and *rpsL* mutations within a mutation induction system; however one must remember that a very small proportion of resistances may be conferred due to mutation outside of the coding region studied (Spindola de Miranda *et al.*, 2001). These forward mutations to antibiotic resistance are by no means the only tools available for detecting mutations at the genome level, e.g. systems using bacteriophages have proven to be highly sensitive.

Molecular Basis of Bacteriophages as Mutation Markers

The use of bacteriophages (phages) as markers for host mutagenesis relies on the ability of the temperate phages to follow a pathway of lysogeny or lysis. Lysogeny is the infective event where the phage genome becomes integrated into the host's DNA and is carried through any subsequent cell divisions. The plaques that arise from a lysogenic/temperate phage are turbid in nature and are comprised of a mixture of lysed cells as well as cells that carry the integrated prophage and are therefore resistant to superinfection by the same phage. A lytic event results in the production of many progeny phage which are released when the host cell lyses. A mutant clear plaque is formed when the infecting phage no longer has the ability to repress its lytic promoters and all progeny phage that are released carry the same lytic nature.

In phage lambda (λ) the control between lysis and lysogeny is perhaps the best known example of repressor-operator interaction and the system is often referred to as the 'genetic switch' (Ptashne, 1992; Friedman and Court, 2001). The pathway between lysogeny and lysis in phage λ is determined by the expression of the early genes, such as *N* and *cIII*, from the left promoter and *cro* and *cII* from the right promoter. The proteins

resulting from these early genes are responsible for determining and regulating whether a lytic or lysogenic pathway will be followed.

The λ repressor protein, encoded by the *cI* gene on the phage genome, is responsible for entering and maintaining the phage in a lysogenic state. Transcription of the *cI* gene is controlled directly by *cI* itself as well as the activity of the *cII* protein which activates the P_{RM} promoter (Ptashne *et al.*, 1980). The λ repressor binds two operators on the phage chromosome, the left operator (O_L) and the right operator (O_R). Each operator region has three binding sites, of which O_{R1} ; O_{R2} ; O_{L1} and O_{L2} need to be bound by repressor protein in dimer form, in order to prevent transcription of the early lytic genes (Friedman and Court, 2001). Virulent (*vir*) mutants have mutated operator sites such that the repressor cannot bind and a lytic cycle is entered, resulting in clear plaque formation. These *vir* mutants form a unique class of mutants, since they would still be capable of infecting a lysogen, as suggested by Donnelly-Wu *et al.*, 1993.

The products of *cII* and *cIII* are positive regulators which assist in the maintenance of lysogeny. The protein product of *cII* activates transcription of the *integrase* gene, which maintains the prophage, as well as regulates the promoter for repression establishment, P_{RE} . The product of *cIII* stabilizes and protects *cII* from enzymatic digestion, ensuring that repression of lytic genes occurs. A mutation that affects the functioning of *cI*, *cII* or *cIII* would result in ineffective repression and hence a lytic pathway would follow. Mutants with altered *cII* or *cIII* would result in a clear plaque phenotype that is slightly more turbid than a full *cI* mutant, but clearer than wild type turbid plaques (Gingery and Echols, 1967). An integration deficient mutant would be unable to insert the prophage into the host genome, but would be capable of repressing early lytic genes. The resulting plaques would therefore be turbid in morphology, however true lysogeny would not take place since prophage insertion could not occur (Gingery and Echols, 1967).

During a standard phage lambda infection the majority of the plaques formed are turbid in nature, however clear plaque mutants (CPM) do arise at low frequencies. Clear plaque

mutants of phage lambda could potentially carry a mutation in either the *cI*, *cII* or *cIII* genes, or in the operator sites which would form a *vir* mutant (Ptashne, 1992).

Bacteriophages as Markers for Mutation

The use of temperate bacteriophages as markers for mutation is by no means a recent development. Ultra-violet reactivation and induction of mutations in phage λ and its host have been studied quite extensively (Weigle, 1953; Defais *et al.*, 1971; Wood and Hutchinson, 1984). Figure 1, on the following page, diagrammatically shows the bacteriophage marker system, note that the signal for host mutation is marked by an increase in frequency of turbid to clear plaque morphology.

Targeted mutagenesis

Weigle (1953) theorised that lambda phage inactivated by UV treatment would be unable to form plaques on a sensitive host since the phage would be unable to replicate and would thus remain in a prophage lysogenic state. Weigle (1953) found that when phage λ was UV irradiated and adsorbed onto a non irradiated host, no mutant phages resulted and normal turbid plaques were seen. When UV treated phage was adsorbed onto UV treated host, an increase in clear mutant phage plaques was observed.

This process was defined by Defais *et al.*, (1971) as UV reactivation, which was “the increased survival of infective centres when UV irradiated phage infects a UV irradiated host, as compared with infection of unirradiated bacteria.” The frequency of clear plaque mutations for λ phage in *E. coli* was shown to increase only when functional *recA* and *lexA* were present (Defais *et al.*, 1971). This suggests that the SOS response plays an important role in this process of targeted mutagenesis (see Figure 1, following page).

Non-targeted mutagenesis

Non-targeted mutagenesis of phage occurs when using non-irradiated phage in an irradiated host system (see Figure 1c), which would allow for the measurement of mutation levels due to host systems acting on undamaged phage DNA in response to the

presence of 'host' DNA damage. Therefore, the repair/mutation process is occurring at an untargeted site within the phage DNA (Wood and Hutchinson, 1984). This system shows that targeted mutagenesis results in higher numbers of mutant phage per burst and increased levels of transition mutations when compared to non-targeted systems, which have a lower number of mutant phage per burst but a higher level of frameshift mutations (Wood and Hutchinson, 1984). An increased mutant phage per burst and higher number of transition mutations in targeted systems can be attributed to the higher level of phage genome damage due to pre-treatment with UV (see Figure 1d).

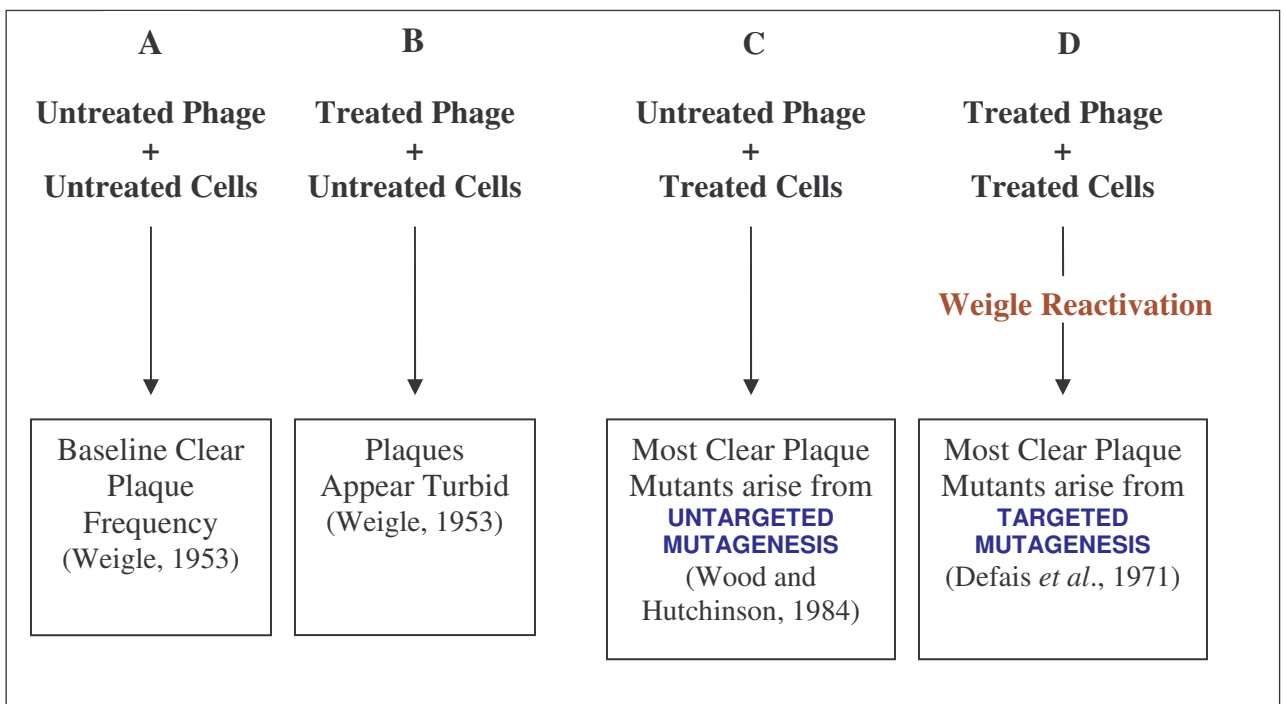

Figure 1. The Bacteriophage Marker System. Under normal growth conditions, clear plaque mutants arise at a low frequency (A). Weigle (1953), determined that UV irradiated phage in untreated cells resulted in normal, turbid plaques (B). Untargeted mutagenesis (C) occurs when an undamaged phage template is introduced into a host that has been subjected to DNA damaging treatment. Targeted mutagenesis (D) occurs at sites on the phage genome that have already sustained DNA damage (UV, Mitomycin C etc).

It is clear that bacteriophage λ can be used as a marker for *E. coli* host mutation and perhaps even SOS induction (Weigle, 1953; Defais *et al.*, 1971; Wood and Hutchinson, 1984). Application of the above systems to mycobacteria should be possible since temperate bacteriophages exist that infect mycobacteria species and mycobacteriophages exist which act in a very similar way to phage lambda in *E. coli*.

Potential for Mycobacteriophages as Markers for Mutation in Mycobacteria

Mycobacteriophages were first discovered just over fifty years ago and at present well over 250 different strains have been classified. Mycobacteriophage L5 is the type species of the genus of 'L5-like viruses' in the family *Siphoviridae*, and has a 52kb double stranded genome with 85 protein-coding and three tRNA genes (Ford *et al.*, 1998). This temperate phage forms stable lysogens in *Mycobacterium smegmatis* such that a single copy of L5 is integrated in the host chromosome at a specific attachment site known as *attB* (Lee and Hatfull, 1993; Pedulla *et al.*, 1996; Datta and Mandal, 1998). Figure 2, below, shows the characteristic head, thin non-contractile tail and sub-terminal tail fibre, of the L5 phage. Sub-terminal tail fibres are responsible for host cell recognition and binding.

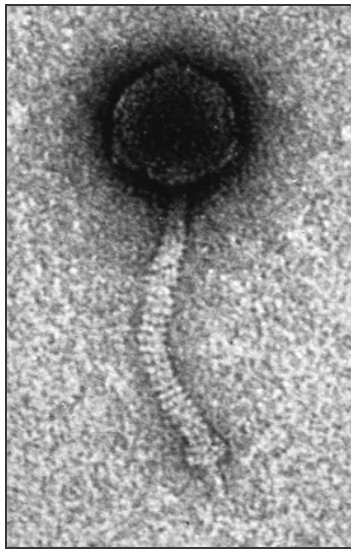

Figure 2. Electron micrograph of Mycobacteriophage L5, Dr B. Duda, University of Pittsburgh. (<http://www.asmta.org/division/m/foto/L5Mic.html>)

Even though L5 and phage λ do not share high levels of similarity at the nucleic acid level, they are similar at the level of genome organization (Hatfull, 2000). The high degree of similarity in organisation of the structural left arm genes of L5 and lambda suggest that these two phages may share a common ancestry (Nesbit *et al.*, 1995). Mycobacteriophage L5 encodes the repressor protein gp71, analogous to the lambda

repressor, which is required for maintaining the state of lysogeny in its host and confers immunity to the host from further infection of related phage particles (Donnelly-Wu *et al.*, 1993). Further evidence of gp71 having repressor functions is evident when comparing mycobacteriophage D29 and L5. D29 is a lytic phage which appears to be very closely related to lysogenic L5 however, the major difference between the two strains is that a 3.6 Kb deletion in D29 results in it lacking a copy of the gp71 gene, hence D29's lytic phenotype (Hatfull, 2000).

The control between a lytic or lysogenic cycle in L5 is determined by the action of the gp71 repressor protein. Similarly to the phage λ system, the L5 gp71 protein represses the P_L promoter which directs the expression of genes responsible for lytic growth and according to Brown *et al.*, (1997) appears to be the only promoter for early lytic transcription. The gp71 repressor binds to an asymmetric DNA-binding site (5'-GGTGGc/aTGTC AAG), so-called the 'stopoperator' sequence, which is orientated in the direction of transcription. Of the 28 theoretical binding sites for gp71, only 24 are actually bound by gp71 *in vitro* (Brown *et al.*, 1997). It has been suggested that when gp71 is bound to its DNA-binding site, it is capable of making contact with the polymerase complex thereby immobilising it or promoting dissociation of the polymerase from the DNA.

Transcription of the gp71 gene is controlled by three promoters P1, P2 and P3, situated in the intergenic region between genes 71 and 72, and to a lesser extent by P_L. These promoters are recognised by host RNA polymerase and appear to be active during lysogeny (Nesbit *et al.*, 1995). During early lysogeny both sets of promoters are active, resulting in gp71 being produced. However, the gp71 protein produced is susceptible to degradation by host enzymes. Nesbit *et al.*, (1995) suggest that the activity of an L5 protein encoded within the 72-82 gene region, and thus controlled by P_L, is responsible for protecting gp71 from enzymatic attack. This allows gp71 repressor to bind to its repressor sites at P_L thereby preventing the phage entering an early lytic cycle. Since P1, P2 and P3 are still active after gp71 has bound P_L basal levels of gp71 may be produced to maintain a lysogenic state. Approximately 80% of L5 infections follow lytic growth,

where at the early lytic stage, gp71 is unable to repress P_L (Nesbit *et al.*, 1995). Figure 3, on page 15, depicts a schematic model for the regulation of phage L5's life cycles. Clear plaque mutants and *vir* mutants, by analogy to the lambda system and shown by Donnelly-Wu *et al.* (1993) may occur for phage L5. A *vir* mutant by analogy would require a mutation at the 'stopoperator' level, which would affect the binding of wild type gp71 to the binding site. This has, as yet, not been demonstrated for phage L5. A gp71 deficient mutant would not produce functional gp71 to bind the 'stopoperator' sites required for the maintenance of lysogeny (Donnelly-Wu *et al.*, 1993) thereby resulting in mutant clear plaques. Nesbit *et al.* (1995) suggest that an L5 protein (analogous to cII or cIII) may exist that protects gp71 from degradation. This protection protein could therefore provide another potential source of clear plaque mutants if it were incapable of protecting gp71.

Lysogeny

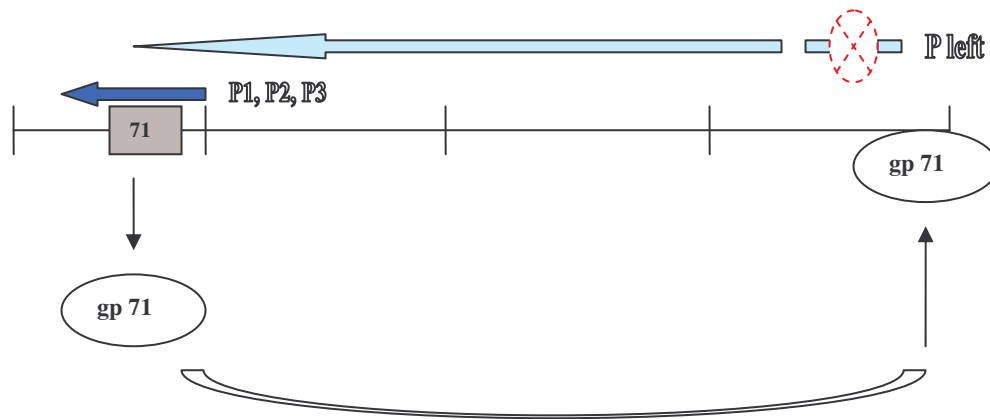

Figure 3a. Diagrammatic representation of phage lysogeny. During initial infection both P_{left} and P_1, P_2, P_3 are transcribed. If there is sufficient gp71 repressor protein transcribed the P_{left} is repressed and the cell enters lysogeny.

Lysis

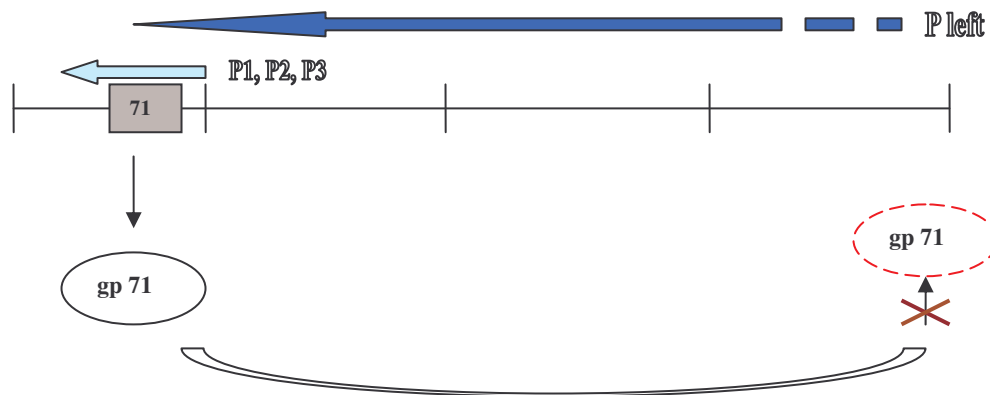

Figure 3b. Diagrammatic representation of phage lysis. If during infection there is insufficient gp71 repressor protein transcribed, or the repressor produced is rapidly degraded by host enzymes, P_{left} will be expressed and the cell will enter lysis.

1.3 AIMS, RESEARCH HYPOTHESIS AND OBJECTIVES

Phage λ and mycobacteriophage L5 seem to have high levels of functional homology, both are lysogenic phages and both seem to control lysogenic to lytic pathways through similar mechanisms. Based on these similarities, mycobacteriophage L5 and its host *M. smegmatis* will be used in the proposed research to investigate the development of a mycobacteriophage marker for host mutation. Since *M. tuberculosis* is a pathogenic mycobacterial species that exhibits extended generation times of up to 20 hours, its close relative *M. smegmatis* is often used for initial mycobacterial protocol development.

Using well characterized potentially mutagenic DNA repair pathways (Durbach *et al.*, 1997; Durbach *et al.*, 2003; Boshoff *et al.*, 2003), the potential of L5 as a mutational marker will be explored. The frequency of clear plaque mutant production under various conditions will be measured, similar to protocols developed for *E. coli* / phage λ (Defais *et al.*, 1971).

Objectives

In order to perform these mutational assays several protocols need to be developed or optimized.

- The initial protocol developments and optimisations are described in Chapter Two.
- In order to determine the conditions at which DNA damage may be occurring in the host strains, as well as Mycobacteriophage L5, ultraviolet dose response experiments were performed (Chapter 3).
- Following this, clear plaque mutant (CPM) production was measured in response to DNA damaging conditions using UV irradiation (Chapter 4).

CHAPTER TWO - OPTIMIZATION OF MYCOBACTERIOPHAGE L5 EXPERIMENTAL TOOLS

2.1 INTRODUCTION

Since this was the first research project in our laboratory to work with mycobacteriophages it was necessary to optimize and develop the relevant phage protocols outlined below.

Phage Diversity and Characterization

Given that it is often necessary to determine or confirm the identity of a phage sample, suitable phage characterization techniques needed to be implemented. There is a wealth of bacteriophages existing in the environment and current estimations suggest that there are potentially 10^{31} tailed phage particles on earth, of which less than 0.0002% have been sampled (Rachel *et al.*, 2002; Pedulla *et al.*, 2003; Rohwer, F., 2003). Many phages have similar plaquing patterns and appear morphologically similar under the electron microscope (Grange and Redmond, 1978). Ackermann (2001) determined that of the 5100 phages studied under EM since 1959 approximately 96% were tailed. Of these tailed phages, 61% belong to the family of Siphoviridae (Ackermann, 2001) – of which mycobacteriophage L5 is a member.

Early studies of phage resulted in the classification of bacteriophages according to their physical properties. In 1933, Burnett proposed a classification system based on his survey of dysentery-coli phages. These early attempts to classify phages were done according to: serological relationships with respect to phage inactivation by different antisera; size of phage particles; sensitivity to inactivation by photodynamic action; sensitivity to citrate in growth media and the outcome of mixed infections (Adams, 1952; Adams and Wade, 1954). Bradley (1967) proposed a method to classify bacteriophages into groups according to their morphology and the nature of their nucleic acid. In 1975, Wisingerova and colleagues attempted to classify mycobacteriophages according to their relative sensitivities to organic solvents and although differences were found it was considered necessary to perform further studies in this regard (Barksdale and Kim, 1977;

Grange and Redmond, 1978). The currently accepted method of phage classification still relies on the Bradley grouping however, host genus has been included as a further subdivision in the groupings (Ackermann, 2001).

With the advent of sequencing technology there is a possibility that the majority of these old classification techniques will become redundant. Many phage genomes have now been sequenced in part/full (Pedulla *et al.*, 2003), including mycobacteriophage L5 (Hatfull and Sarkis, 1993). Phages in general are genetically very mosaic (Hendrix *et al.*, 2003; Pedulla *et al.*, 2003) thus, utilizing sequence data that is available; it has become possible to create a genome-based taxonomic system for phage (Rohwer and Edwards, 2002). The availability of sequence data has allowed for the comparison and identification of phage through a number of techniques, including restriction digestion analysis.

Phage Propagation, Concentration and Purification

Most phage research requires the production of high titre phage stocks that are pure and free of host cell contamination. High titre stocks ($10^{10}/10^{11}$ pfu/ml) of the lytic phage D29 can be produced through the infection of a fresh, mid-log, culture of sensitive host cells until the supernatant clears due to cell lysis (Bowman, 1958; Sellers and Runnals, 1961). Grange and Redmond (1978) reviewed the development of techniques for producing high titre phage stocks and briefly covered issues such as the use of plastic sponges (for increasing the surface area of the culture) and the development of polyethylene glycol 6000 (PEG 6000) for phage precipitation.

The development of phage stock production techniques with respect to temperate phages has required the development of methods to concentrate the phage. Temperate phages enter a cycle of lysogeny or lysis hence culture lysing techniques do not result in high titre lysates since not all of the cells will lyse to release progeny. The temperate phage L5 forms stable lysogens which are only moderately inducible with ultraviolet light (Donnelly-Wu *et al.*, 1993) hence culture lysates of this phage exist with low levels of free phage. Soloff *et al.*, (1978) utilized cesium chloride (CsCl) gradient centrifugation

in order to concentrate the temperate mycobacteriophage R1. This method resulted in a titre of approximately 10^{12} pfu/ml (Soloff *et al.*, 1978). Pedulla and colleagues routinely utilize PEG 6000 precipitation and CsCl density centrifugation to produce high titre stocks of L5 (Pedulla, M.³).

Phage Inactivation

It is often necessary to inactivate free phage within an experimental system and hence a suitable inactivator was required for mycobacteriophage L5. As stated previously, mycobacteriophages tend to be solvent sensitive (Barksdale and Kim, 1977) and chloroform has been shown to inactivate mycobacteriophage D29 (reviewed in Rado and Bates, 1978) the close relative of L5. Since organic solvents are often used to solubilize lipid membranes, including mycobacterial cell walls (Grange and Redmond (1978), they are not good phage inactivators due to their potential effect on host cell viability.

Ellis and Delbrück (1939) found that phage suspensions were inactivated by the polysaccharide fractions of agar cultures but did not study this phenomenon further. Delbrück (1945) later investigated the effect of specific antisera on the growth of bacteriophages. It was found that the antiserum produced against phage was unable to inactivate attached phage or phage that had already infected the host cells but free phage was completely inhibited (Delbrück, 1945). Antisera can be produced in a variety of small laboratory animals, ranging from guinea pigs (Sellers and Runnals, 1961) to albino rabbits (Bowman, 1958).

More recent research has shown that the use of Ferrous Ammonium Sulphate (FAS) on mycobacteriophage D29 inactivates free phage in culture medium (McNerney *et al.*, 1998). McNerney *et al.* (2004) used FAS at a concentration of 10mM to inactivate unbound phage D29. The inactivation was followed by a four times dilution with fresh broth, to neutralize the effect of the FAS, such that subsequent progeny phage remain undamaged. FAS does not appear to affect phage replication in previously infected host

³ This protocol was kindly supplied by Marisa Pedulla via email correspondence.

cells, therefore successfully infected cells that are treated could maintain their infection (McNerney *et al.*, 1998).

L5 Lysogeny

Isolation or production of a lysogenic culture is often necessary for phage experiments. Since mycobacteriophage L5 is a temperate phage, infection results in either lysis or lysogeny (Madigan *et al.*, 1997). During lysis the host cells lyse to release progeny phage, thereby destroying the viability of these cells. Alternatively, lysogeny results in the prophage being incorporated into the host genome. Early studies showed that changes in colony morphology in mycobacterial cultures could often be attributed to positive lysogenic status (White *et al.*, 1962). Lysogenic mycobacterial strains have been shown to often form smoother colonies in comparison to those of wild type strains (White *et al.*, 1961). Grange and Bird (1978) linked the production of mucoid colonies in different *M. fortuitum* and *M. kansasii* strains to the presence of lysogenic and defective lysogenic phage (Reviewed in Grange and Redmond, 1978).

Lysogens spontaneously release or 'leak' phage into their growth media, however, it has been shown that lysogens of L5 are very stable and are only mildly inducible by UV (Donnelly-Wu *et al.*, 1993). If the prophage combines with the host chromosome, a site-specific reversible event involving recombination at the host *attB* and phage *attP* sites occurs (Peña *et al.*, 2000; Lewis and Hatfull, 2003). This highly specific event has set the foundation for molecular confirmation of lambda prophage integration by PCR (Powell *et al.*, 1994) and by analogy can be applied to the L5 system (Peña *et al.*, 2000). Since the host *attB* and phage *attP* sites undergo re-arrangement during prophage insertion, the integrity of these sites confirms the presence or absence of a prophage (see Figure 5, page 30).

2.2 AIMS AND OBJECTIVES

Prior to conducting the DNA damaging experiments it was necessary to first optimize and implement phage experimental tools that were specific to mycobacteriophage L5 since this phage had not been previously worked on in this laboratory. Therefore, our objectives were as follows:

- Confirmation of mycobacteriophage L5 genotype for the sample of phage material obtained from Dr M Pedulla.
- Development of high titre L5 phage stocks.
- The optimization of an L5 inactivation protocol.
- The production of a *Mycobacterium smegmatis* mc²155 lysogen containing the L5 prophage.
- Identification of a clear plaque mutant (CPM) of L5.

2.3 METHODS

Confirmation of Mycobacteriophage L5 Genotype

Reference Sequence Retrieval: The sequence for mycobacteriophage L5 was retrieved from the PubMed/NCBI database (Accession No: NC_001335). This sequence was then entered into the Shareware Program Restrict (Roberts and Macelis, 1999) to determine the predicted restriction enzyme patterns. Restriction enzymes with fewer than thirty recognition sites were selected.

Bacteriophage L5 DNA Extraction: Two DNA extraction protocols were followed. For both protocols the initial phage samples were treated with EDTA (20mM), Proteinase K (50µg.ml⁻¹) and SDS (0.5% w/v), for 1 hour at 56°C, prior to phenol treatments. The first method: Isolation of Bacteriophage DNA (Sambrook *et al*, 1989) utilized phenol:chloroform and 3M sodium acetate (0.3M, pH 5.2) as the salt for precipitation. DNA was then precipitated by the addition of ice cold 99% ethanol and allowed to stand at room temperature for 30 minutes. The DNA was pelleted in a desktop microcentrifuge and then ethanol washed.

The second method, adapted from Faure *et al*, (1992), utilized only phenol, followed by 4M lithium chloride precipitation. Salts were precipitated for 3 minutes on ice, after which the supernatant was transferred to a clean microcentrifuge tube. At this stage ice cold 99% ethanol was added and the DNA was allowed to precipitate for one hour at -70°C, after which it was pelleted in a desktop microcentrifuge and washed in 70% ethanol.

All DNA pellets were air-dried and then resuspended overnight in PCR grade water, at 4°C. An equal volume of DNA (2µl) from each protocol was run on a 0.8% TAE agarose gel at 55mAmps. The gels were photographed using a standard UV gel documentation system (UVP BioDoc-It, Model LM-26E).

Restriction Digestion: The restriction enzymes selected for digestion of the isolated L5 DNA were: *Kpn* I (9 recognition sites), *Xba* I (2 recognition sites) and *Bam* HI (27 recognition sites). The digests were set-up according to manufacturer's recommendations (Amersham Biosciences), using between 0.5 - 1µg of the isolated L5 DNA and was incubated at 37°C for 3 hours. Double digests using *Kpn* I / *Xba* I were

carried out by first digesting the DNA with *Kpn* I followed by 3M sodium acetate and ethanol precipitation. The pellet was then dried and resuspended in 15µl PCR grade water. The restricted L5 DNA was then further digested with *Xba* I and ethanol precipitated.

Agarose Separation of Digests: Digested L5 DNA was run on a 0.7% TAE agarose gel at 55mAmps. The gels were photographed as above.

Development of High Titre Stocks

Production of Large Scale L5 Lysates: On average 30 plates with more than 1000 visible plaques were used. Phage buffer (10mM Tris (pH8), 10mM MgSO₄, 68mM NaCl, 10mM CaCl₂) was poured onto each indicator plate/soft agar overlay to just cover the surface and placed at 4°C, overnight. Phage buffer recovered from each plate was then pooled and centrifuged at 3500g for 5 minutes. The supernatant was then transferred to a clean centrifuge tube for phage precipitation using 10% PEG 6000 and NaCl to 1M, gently shaken overnight at 4°C. Centrifuge at 3500g, 5 minutes. Cold phage buffer was used to resuspend the pellet, followed by gentle shaking overnight at 4°C.

Centrifugation and Dialysis: Resuspended phage pellet was then layered onto a 30%-90% glycerol gradient, sucrose gradient or a cesium chloride (CsCl) step gradient (prepared according to Sambrook *et al.*, 1989, using phage buffer). All gradients were run in a Beckman SW28.1 rotor in clear polypropylene tubes, at 22 000rpm for 2 hours, at 4°C. The bluish viral band was then removed from the gradients using a sterile glass Pasteur pipette and placed in a dialysis tube which has been pre-soaked in phage buffer. Dialysis was carried out over 36 to 48 hours, where the phage buffer was replaced at least twice.

Phage Inactivation

FAS Inactivation of L5: Freshly prepared, filter sterilized FAS was added to L5 phage samples (1×10^4 pfu.ml⁻¹) to a final concentration ranging from 1µM to 10mM. Samples were allowed 5 minutes for inactivation and were then plated in overlays and on indicator plates.

Isolation of an *M. smegmatis* mc²155 (L5) Lysogen

Isolation of L5 Lysogen: Since L5 is a temperate phage, any turbid plaque will be a mixture of lysed cells, potential lysogens and resistant cells. Based on this, four plaques were arbitrarily chosen from plates of overlays containing L5 phage. The plaques were picked and streak plated directly onto LA plates. The resulting cultures were then passaged a minimum of three times onto fresh LA plates. The resulting cultures were then streak plated onto indicator plates to confirm the presence of phage (since a lysogen would 'leak phage' causing lysis of the sensitive cells in the indicator plates). Three of the original samples were kept for future lysogen work. These lysogen cultures were frozen as freezer stocks and a 1ml sample checked for free phage.

Microbiological Confirmation of L5 Lysogen: Cultures of lysogen were checked periodically for phage production by centrifuging 1 ml samples in a desktop centrifuge for 5 minutes, 12 000rpm. The resulting supernatants were then plated on overlays containing sensitive wild type cells. The presence of plaques confirms the presence of free phage in the original lysogen culture.

PCR-based Confirmation of L5 Lysogen: The primer sequences listed in Table 5, page 30, (**MSRev:** 5' ACGTGGCGGTCCCTACCG; **L5For:** 5' CTTGGATCCTCCCCTGCGC; **L5Rev:** 5' AATTCTTGACAGACCCTGGA) were kindly obtained from Dr. E. Machowski. The primer MSFor was redesigned such that the amplicons obtained from non lysogen containing samples (354bp, 326bp; see Table 5, page 30) would be visually distinguishable from the positive lysogen amplicon (282bp, see Table 5). The redesigned primer sequence is **MSFor:** 5' ACCTTGCTCTTGATGC. The primers were used under standard PCR conditions as set out in the manufacturer's guidelines for the use of Bioline BioTaqTM DNA Polymerase (denaturation: 95°C, 45 seconds; annealing: 30 seconds; elongation: 72°C, 30 seconds). The optimum annealing temperatures for each primer set were determined by temperature gradient PCR. The primers combinations used are shown in Figure 5. The primers were used at a final concentration of 0.2µM per primer, in a 50µl reaction volume.

All template samples were prepared from fresh overnight cell cultures (OD_{600nm} 0.8 – 1.0) or phage stocks. An aliquot of 100µl was boiled for 5 minutes and allowed to cool. Samples were briefly centrifuged and then diluted 1:10 with PCR grade water.

The resulting PCR products were run on a 1% TAE Agarose gel, at 55mA. The resulting gels were photographed as above.

Identification of L5 Clear Plaque Mutants

Potential CPMs were recovered from overlay plates used for the titrating of a high titre L5 preparation. These putative CPMs were plaque picked and placed in overlays containing 500 µl of a fresh lysogen culture (OD_{600nm} 0.6 – 0.7). Wild type phage was plated as a negative control on the lysogen. Overlay plates were incubated for 36 – 48 hours at 37°C, after which the presence/absence of plaques was recorded.

2.4 RESULTS

Development of High Titre Stocks

High titre phage stocks of the L5 sample were required before the identity of the phage sample could be determined. The high titre phage stocks would also be required for future experiments and therefore a number of production techniques were investigated. Sucrose gradients for high titre stock preparation showed very diffuse banding which was difficult to remove from the gradients without causing mixing. These sucrose gradients were thus discontinued. Glycerol and cesium chloride gradients both showed definite bluish viral banding which could be removed from the gradients with relative ease. After the viral bands were removed from the gradients, they were dialysed against fresh phage buffer. The titre for each sample was determined through standard plaque titrating. See Table 2, below, for the average concentrations of phage removed off the gradients.

Table 2. Average phage titres of samples removed from glycerol and cesium chloride gradients after ultra-centrifugation.

Gradient Method	Titre (pfu/ml)
Glycerol	$(6.71 \pm 1.5) \times 10^7$
Cesium Chloride	$(2.13 \pm 0.2) \times 10^{10}$

(Titres calculated as an average of five individual gradient preparations, each with internal duplicates for each gradient type.)

It is clear from the above data that cesium chloride gradients yield a titre of phage approximately 500x higher than glycerol gradients. Since the yield of phage was noticeably higher when using cesium chloride gradients, this method was used in all future stock preparations.

Confirmation of Mycobacteriophage L5 Genotype

In order to confirm the identity of the phage sample received from Dr Pedulla, restriction digests needed to be performed. Initially, two different methods of DNA isolation were carried out in order to determine which would produce a higher yield of digestible DNA. The method detailed in Sambrook *et al.*, (1989) resulted in 2 to 3 fold higher concentrations of DNA when compared to the adapted Faure (1992) method, as judged

by visual inspection (see Figure 4a). The DNA isolated from both methods was however of high enough concentration for restriction enzyme digestion.

The L5 restriction digests were analysed by separating the digested DNA on a 0.7% TAE agarose gel (Figure 4b). The restriction profile of the L5 samples were analysed and the fragment lengths determined by comparison with the molecular weight marker.

Comparison of the expected fragment lengths and actual fragment lengths is shown in Table 3, on the following page. It can be seen that the resulting fragments create a profile very similar to that which was expected, with exception of a few fragment lengths that had to be extrapolated since they were beyond the range of the molecular weight marker that was used. It was thus concluded that the phage sample was a pure stock of mycobacteriophage L5.

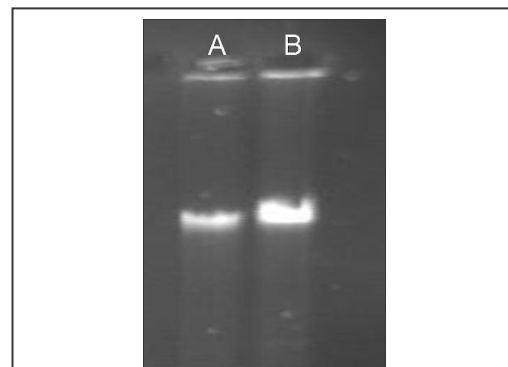
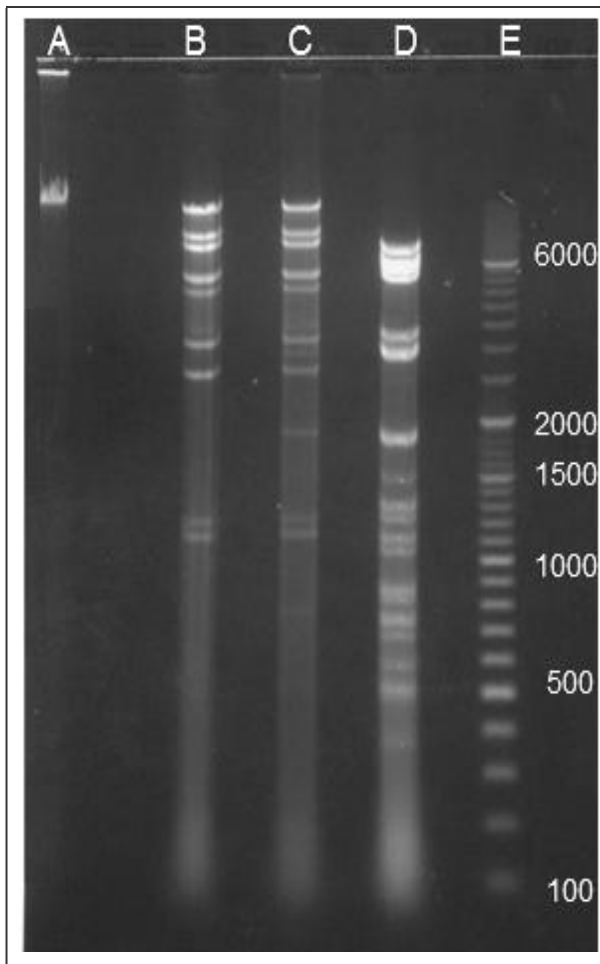

Figure 4A Isolated phage L5 DNA, 0.8% TAE agarose gel. Lane A: L5 DNA isolated from 'Faure' Method; Lane B: L5 DNA 'Sambrook *et al.*, 1989' Method

Figure 4 B Restriction products of the Mycobacteriophage L5 sample, 0.7% TAE agarose gel. Lane A: Undigested L5 DNA. Lanes B, C, D: *KpnI* digest, *KpnI/XbaI* digest, *BamHI* digest respectively. Lane E: Mw Marker (O'RangeRuler 100+500bp DNA Ladder)

Table 3. Table of expected L5 digest fragment lengths and actual fragment lengths in bp.

<i>Kpn</i> I Digest		<i>Kpn</i> I / <i>Xba</i> I Digest		<i>Bam</i> HI Digest	
Expected Fragments (bp)	Actual Fragments (bp)	Expected Fragments (bp)	Actual Fragments (bp)	Expected Fragments (bp)	Actual Fragments (bp)
189*		189*		75, 127, 173*	
1148	1124	259*		372,	333
1240	1248	780	730	489,	443
2690	2669	1148	1130	509, 511, 585,	533
3251	3306	1240	1259	653, 687,	649
3543	4448	1910	1949	738, 758,	714, 768
5508	5447	2992	2918	832, 859, 880,	794, 943
8078	6972*	3543	3306,	1064, 1135, 1257,	1064, 1238
9495	8128*	5508	4755, 5301	1333,	1309
17155	10 688*	8078	6972*	1860, 1892,	1550, 1871
		9495	8128*	3010, 3104, 3411,	3154, 3538
		17155	10 688*	5519, 6088,	5228, 5554*
				6665, 7711	6141, 8270*

*Fragments were too small to visualize on a gel with the larger fragments

*Fragments were extrapolated out and therefore not a true reflection of their lengths.

Phage Inactivation

In order to perform the mutant induction experiments (outlined in Chapter 4) it was necessary to investigate a phage inactivation system that would effectively inactivate unbound, free phage. Since FAS (10mM) has been shown to inactivate phage D29 (McNerney *et al.*, 1998), a close relative of L5 (Hatfull, 2000), we were interested in determining its efficacy against phage L5. In order to test this, FAS at various concentrations was mixed with suspensions of L5. These experiments showed that a minimum end concentration of 1mM was required to inactivate free phage, see Table 4, on the following page. When FAS is added to concentrations below 1mM, there does not seem to be any noticeable effect on the viable phage concentration, this was supported by the lower concentration plates being almost identical in terms of plaque number to the control plates (0mM). These experiments have confirmed that FAS is a suitable inactivator of mycobacteriophage L5 at concentrations as low as 1mM.

Table 4. Inactivation of mycobacteriophage L5 by various concentrations of FAS.

FAS Concentrations					
0mM Control	1μM FAS	10 μM FAS	100μM FAS	1 mM FAS	10mM FAS
~1000 Plaques	~1000 Plaques	~1000 Plaques	~1000 Plaques	No Plaques	No Plaques

*Plated in duplicate.

Isolation of an *M. smegmatis* mc²155 (L5) Lysogen

The mutation induction experiments as well as the CPM identification protocol necessitated the isolation of an *M. smegmatis* mc²155 (L5) lysogen, which was prepared as described in the methods. During the isolation of this lysogen, confirmation of the presence of phage was carried out using both microbiological and molecular techniques. Clearings on indicator plates, surrounding the original culture streaks, confirmed the presence of phage (results not shown). Lysogen freezer stocks were confirmed for the release of free phage into the growth media by standard plaque titration prior to freezing (results not shown).

The presence of prophage in the lysogens was also confirmed by PCR analysis. The primer pairs indicated in Table 5, on the following page, were used in PCR reactions with each of the three templates (lysogen, wild type *M. smegmatis* mc²155, L5). A negative water control was also included. Referring to Figure 6 (pg 31) it can be seen that the predicted amplicons (shown in Table 5, on the following page) are present on the gel. Lanes C and D (L5For + MSRev with L5 and the lysogen respectively) each show banding that is approximately 280bp in length. The banding in lane C is less intense than that in lane D, which may suggest that carry through of lysogen DNA occurs during high titre phage preparation. Lane G shows banding at 350bp and was the only amplicon for the MSFor + MSRev primer pair. Similarly, lane N shows banding at 325bp and was the only amplicon for the L5For + L5Rev primer pair. Coupled with the microbiological techniques, data gained from the PCR has confirmed the presence of an integrated prophage present in the host genome.

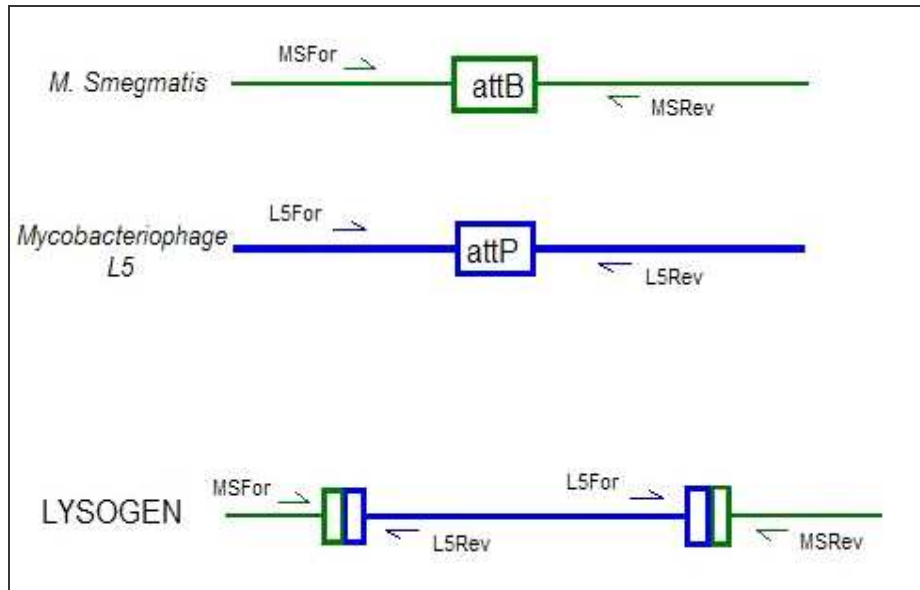

Figure 5. Schematic representation of the PCR-based confirmation technique used on *M. smegmatis* mc²155 wild type and lysogen strains.

Table 5. Primer pairing and expected amplicon yields with regards to template DNA used.

Primer Pair	Annealing Temperature °C	<i>M. smegmatis</i> mc ² 155	L5	Lysogen
MSFor + MSRev	55°C	354bp	-	-*
L5For + L5Rev	55°C	-	326bp	-
L5For + MSRev	59°C	-	-	282bp

‘-‘ No amplicon expected

* Since the entire L5 phage genome would be present as an integrated prophage within the L5 lysogen the expected amplicon for this primer pair would be 52Kbp. This amplicon length is beyond the range of standard PCR techniques.

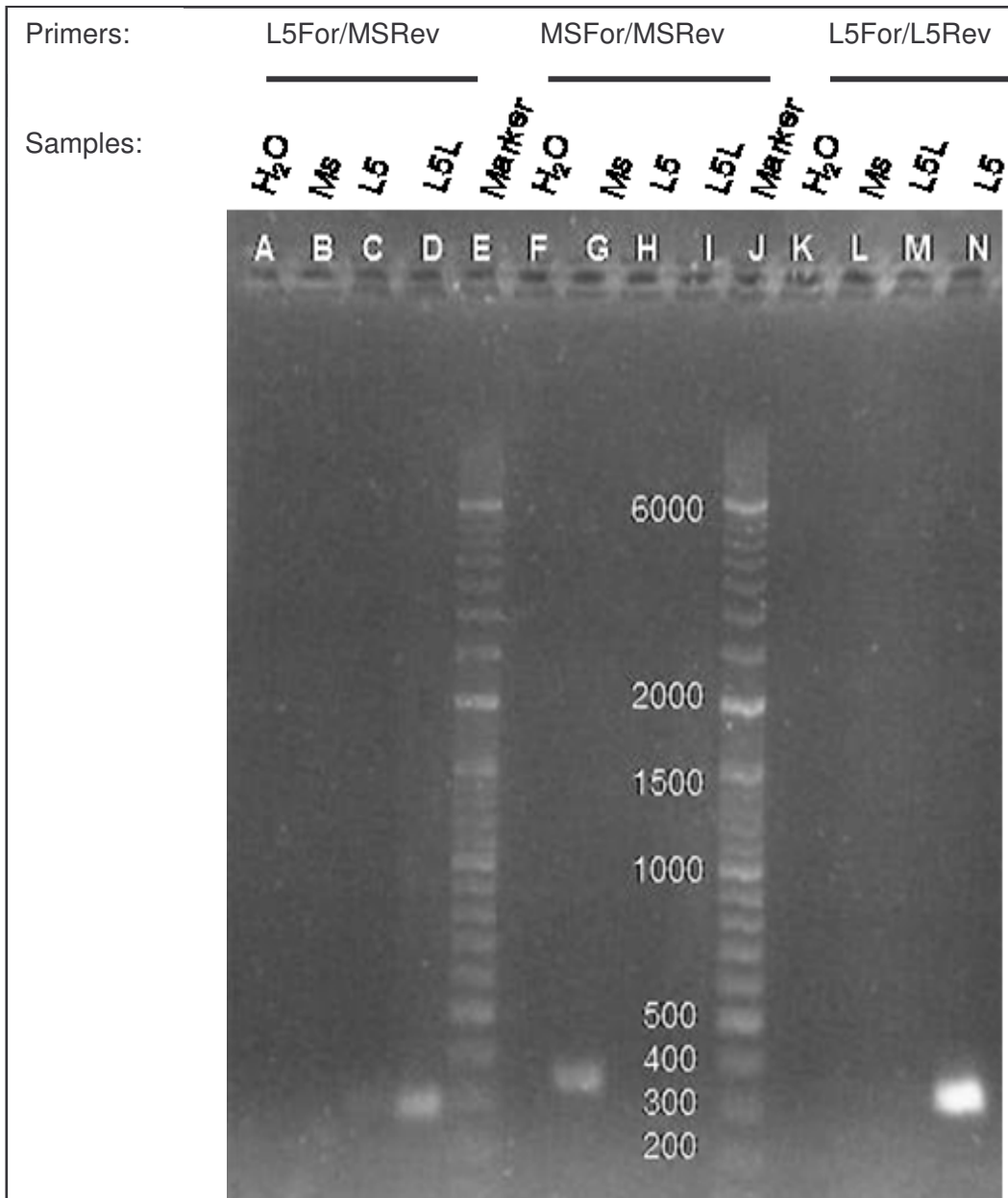

Figure 6. Confirmation of the Status of the *M. smegmatis* mc²155 (L5) Lysogen, 1% TAE agarose gel. Primer pairs used as well as samples are indicated.

H₂O = water control; MS = Wild type *M. smegmatis* mc²155;

L5 = Mycobacteriophage L5 lysate; L5L = *M. smegmatis* mc²155 (L5) Lysogen

Band Sizes: Lane C and D: 277bp; Lane G: 344bp; Lane N: 321bp

Molecular Weight Marker: O'Range Ruler (Fermentas)

Isolation and Confirmation of Clear Plaque Mutants

In order to ensure that the clear plaque mutant phenotype being assessed in the induction assays (Chapter 4) is a true mutant phenotype it was necessary to develop methods to isolate the CPMs and confirm their mutant phenotype. After a prophage has successfully inserted into the host genome, the maintenance of this inserted state relies on the activity of the phage repressor (Ptashne *et al.*, 1980). The ability of gp71 to bind the L5 stoperators (Brown *et al.*, 1997) on the phage genome results in the repression of the early lytic genes (Ptashne *et al.*, 1980; Brown *et al.*, 1997) and hence lysogeny. If however, the phage repressor is unable to bind to the stoperator sites either due to dysfunctional repressor or an altered binding site, a clear plaque mutant will arise. The natural level of clear plaque mutants is estimated at 1×10^{-3} within an untreated population of mycobacteriophage L5 (Donnelly-Wu *et al.*, 1993).

Putative mycobacteriophage L5 clear plaque mutants were visualised against a background of wild type phage that were plated at high concentrations, min: 2.3×10^5 pfu/ml, see Figure 7, below. Attempts were made to plaque pick these small 'clear plaques' using surgical needles, however we were unable to purify these to single plaques as the high wild type plaque background appeared to be required for them to be evident.

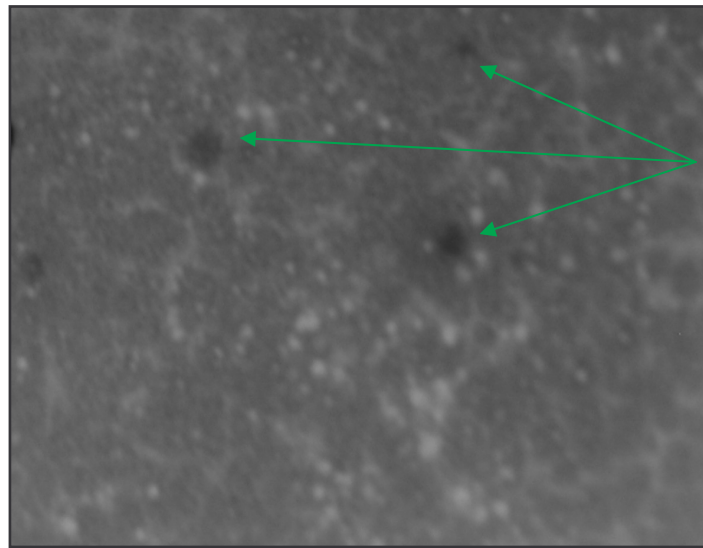

Figure 7. Mycobacteriophage L5 clear plaque mutants (→) visualised against a background of wild type turbid plaques.

Since a proportion of the suspected CPMs should have mutations in their stoperator sites and therefore be *vir* mutants, we reasoned that they should be capable of plaquing on a lysogen. Given the large number of stoperator sites (24) present on the L5 phage genome, a fairly high proportion of the CPMs isolated, should be stoperator mutants. The data from these plating experiments showed that almost 76% (n = 78) of the putative CPMs plaqued on the lysogen. This suggests that approximately three quarters of the clear plaque phenotype are true *vir* mutants of L5.

2.5 DISCUSSION

The DNA isolation procedures used on the mycobacteriophage L5 sample both result in DNA which is of a high enough concentration for restriction digestion. The digestion profiles of the isolated DNA indicate that the sample was a pure stock of Mycobacteriophage L5. This pure stock of L5 was then used to create high titre phage stocks.

A protocol using PEG/NaCl precipitation followed by re-suspension and density gradient centrifugation was optimised for use in our laboratory. Although the glycerol gradients were simpler to construct they yielded lower phage concentrations than the cesium chloride gradients. Soloff *et al.* (1978) utilized a similar method to our CsCl gradients but achieved a titre of 10^{12} pfu/ml of temperate phage R1. The discrepancy in titre may be attributed to the method of removing the phage from the gradient. The method described in this dissertation requires that the phage band be removed from the gradient by manual pipetting. Soloff *et al.* (1978) utilized a UV scanner to assist in the removal of the phage band by an automated fractionator. The fractionator was set to remove 0.6ml aliquots from the gradients and test each aliquots UV absorbance. This technique would ensure that only virus containing fractions be pooled for the final phage stock, hence a higher titre.

Since high titre stocks could now be routinely produced, it was necessary to explore the potential of FAS as an L5 inactivator. The data from the phage inactivation experiments demonstrated that FAS is a suitable inactivator of unbound L5 phage, as expected from

the D29 data (McNerney *et al.*, 1998), and can be used at a relatively low concentration of 1mM. McNerney *et al.*, (2004) utilized FAS at an end concentration of 10mM to inactivate residual free phage D29; and the FAS was then neutralized in the samples by the addition of four times the volume of fresh assay broth. Our data suggests that concentrations of FAS lower than 1mM are ineffective in inactivating phage and hence diluting treated samples down to a lower concentration would eliminate the inactivation effect of the FAS.

The presence of the L5 prophage in the potential lysogen cultures has been confirmed through molecular techniques, while prophage induction was confirmed by standard microbial techniques. The ability of the culture filtrates to create plaques on sensitive indicator plates indicated that phage was actively being produced and released from the cells. Amplification of the 282bp integration fragment for each culture confirmed that the prophages were indeed site-specifically present within the host genomes. Powell *et al.* (1994) developed a PCR-based system which detects a single copy of integrated lambda prophage in *E. coli*. The Powell *et al.* (1994) system is analogous to the system described in this work, where the integrity of the host *attB* and phage *attP* sites has proved to be a sensitive tool for confirming the status of lysogenic cultures.

Since the L5 lysogens carry an L5 prophage within their genome, any incoming phage DNA related to that of the prophage will be suppressed due to immunity to super-infection. The term super-infection immunity relates to the presence of phage repressor protein, within the lysogen cell, which actively binds to related incoming phage DNA thereby suppressing its gene expression. The ability of $\pm 75\%$ of picked CPMs to plaque on the constructed L5 lysogen suggest that a majority of the mutations resulting in the CPM morphology are due to ‘stopoperator’ related mutations. The mutations that (i) result either in changes of the gp71 protein itself or (ii) result in changes in any proteins that may protect gp71 from enzymatic degradation, will not result in plaquing on the lysogen, since the lysogen actively produces functional gp71. This functional gp71, produced from the inserted prophage in the lysogen, would repress any new incoming phage DNA.

These types of mutants potentially make up a large proportion of the remaining 25% of CPMs that do not plaque on the lysogen.

Donnelly-Wu *et al.* (1993) suggest that at least two (possibly even three) separate mutations may be required to produce a virulent phenotype which would be capable of plaquing on an L5 lysogen. This suggests that a relatively low proportion of the 28 potential 'stoperator' sites (Brown *et al.*, 1997) would be essential for the maintenance of lysogeny in L5. The frequency with which we have managed to isolate virulent mutants does not support the supposition made by Donnelly-Wu *et al.* (1993). Since the 'stoperator' sites described by Brown *et al.* (1997) are present throughout the entire 52Kb phage genome, the presence of mutations within more than one of these 13bp 'stoperator' sites seems unlikely to occur at such a high frequency. The data leads to the suggestion that most of the stoperators are indeed essential due to our high proportion of *vir* mutants obtained. It is currently unknown how many of the 28 'stoperator' sites present on the L5 genome are essential for the maintenance of lysogeny.

2.6 CONCLUSION

With respect to the aims and objectives laid out for this chapter:

- The identity of the phage sample was confirmed, through restriction digest analysis, to be Mycobacteriophage L5.
- A method for the production of high titre phage stocks has been developed and is routinely utilised to produce stocks of L5 phage ($\sim 10^{10}$ pfu/ml).
- FAS is a suitable inactivator of L5 and should best be used at concentration of 10mM to ensure complete phage inactivation, followed by a 1:100 dilution of the samples to allow any phage released from the cells thereafter to remain viable.
- A lysogen of Mycobacteriophage L5 in *M. smegmatis* mc²155 was created and the presence of the prophage confirmed through both microbiological and PCR based techniques.
- Clear plaque mutants (CPMs) of L5 have been identified. Our data suggests that approximately 75% of isolated CPMs plaque on a lysogen and thus may potentially have mutations in the gp71 binding regions, i.e. the ‘stoperator’ sites.

The optimization of the basic methodologies described above was necessary prior to the development of the DNA damage and mutation induction experiments. Although a purifiable CPM was not obtained we have confirmed that a large proportion of the putative CPMs that were isolated were indeed *vir* mutants of L5. Based on the findings presented in this chapter it was possible to continue with the main focus of this research, namely the development of L5 as a marker for mutation induction in *M. smegmatis*.

CHAPTER THREE – DETERMINATION OF DOSE RESPONSE TO ULTRA VIOLET IRRADIATION

3.1 INTRODUCTION

Ultraviolet irradiation of bacterial cells may have a direct impact on the cellular DNA, which can result in the linkage of adjacent pyrimidines and thus the formation of thymine dimers (Madigan *et al.* 1997; Sinha and Häder, 2002). These thymine dimers distort the helical shape of the DNA strands and often block the replication fork (Mathews and Van Holde, 1996). The consequence of a stalled replication fork may be a loss in viability as can be inferred from studies with a *M. bovis recA* mutant (Sander *et al.*, 2001).

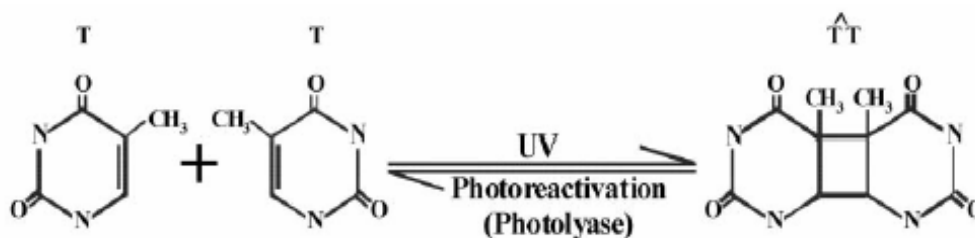

Figure 8. Formation of the toxic and mutagenic DNA lesion, the pyrimidine dimer. This schematic diagram shows the formation of a thymine dimer and its photoreactivation by photolyase (Sinha and Häder, 2002).

Bacteria have several systems of dealing with the DNA-damaging consequences of UV irradiation. Some mechanisms are non-mutagenic, such as photo-reactivation (Dulbecco, 1949), while others may result in enhanced mutagenesis. The latter mechanisms will be dealt with in more detail below and as part of the next chapter. Photoreactivation, a non-mutagenic process, is one of the processes by which these thymine dimers can be repaired, see Figure 8. In *E. coli*, the *phr* gene product, a photolyase, binds to the thymine dimer under dark conditions (Sancar *et al.*, 1983). Exposure to light allows folic acid to absorb energy and this activated folic acid, acting as a cofactor to the photolyase enzyme, supplies the energy required to break the dimer bond (Hamm-Alvarez *et al.*, 1990; Sinha and Häder, 2002).

Mechanisms that respond to UV-irradiated DNA damage and cause enhanced mutagenesis in *E. coli* include the error-prone DNA polymerases DNA Pol IV (Smith and Walker, 1998; Tomkins *et al.*, 2003) and PolV (O'Grady *et al.*, 2000). At least two

homologues of PolIV have been found in *M. tuberculosis* (Cole *et al.*, 1998) and possibly three in *M. smegmatis* (D. Warner. Personal communication; Table 1: Chapter 1). Miroslav Radman put forward the hypothesis that the inducible SOS repair system, which regulates the expression of PolIV and PolV, is activated in response to DNA damage and mutagenesis (Janion, 2001). Since Radman was emotionally bound to the sea, he termed this damage response system in bacteria the ‘SOS Response’, after the morse code for ‘Save Our Souls’, since the expression of SOS regulated genes allow the error-prone bypass of damaged lesions by the progression of the replication fork (Reviewed in Janion, 2001). The SOS response is controlled by RecA co-proteolytic cleavage of the LexA repressor and occurs when high levels of DNA damage are present in an organism’s genome (Smith and Walker, 1998). It has been shown to lead to increased levels of mutagenesis through the action of a suite of polymerase-like mutator genes, including *umuC* and *dinB* which encode PolV and PolIV respectively (Boshoff *et al.*, 2003; Friedberg *et al.*, 2002; McKenzie and Rosenberg, 2001; Tomkins *et al.*, 2003).

The SOS response is initiated by the activation of RecA. In *E. coli* this activation occurs when RecA forms a nucleoprotein complex by binding to ssDNA, thereby acquiring a co-protease activity to form RecA* (Janion, 2001). RecA* (the activated form of RecA) assists the LexA repressor in its autodigestion and thereby allows it to be freed from the bound promoter sites resulting in the induction of the SOS response (Smith and Walker, 1998). By examining the SOS response in single cells Friedman *et al.* (2005) found that the promoters of *lexA*, *recA* and *umuDC* are stimulated in three accurately timed and synchronized patterns, suggesting that the SOS response is indeed a tightly regulated yet complex system. The exact number of LexA regulated SOS genes in *E. coli* is unknown although it has been suggested that the number most probably does not exceed 68 genes (Janion, 2001) and is more likely to be in the region of 30 genes (Friedman *et al.*, 2005).

Mycobacteria have been shown to possess the key features of an SOS response, namely an inducible *recA* promoter coupled with a functional LexA repressor that loses its DNA binding capacity after DNA-damaging treatment (Durbach *et al.*, 1997; Movahedzadeh *et*

al., 1997). Even though RecA induction after DNA damage does occur in *M. smegmatis* and *M. tuberculosis*, the induction is very slow in *M. tuberculosis* with maximum expression of RecA only detected 18 – 36 hours after the DNA damaging treatment (Papavinasasundaram *et al.*, 2001). This is in contrast to the maximal *recA* expression that occurs approximately three hours after DNA damage exposure in *M. smegmatis* (Durbach *et al.*, 1997). *M. bovis recA* mutants have also been shown to be more sensitive to DNA damaging agents *in vitro* than their wild-type counterparts (Sander *et al.*, 2001) thereby suggesting that RecA plays a role in an SOS-type response in mycobacteria. Although there is no doubt that this potential SOS-type response exists, it has been suggested that a second DNA damage response system, distinct from the SOS LexA repressor system, may exist in *M. tuberculosis* (Brooks *et al.*, 2001).

The activities of error-prone polymerases in *E. coli*, especially PolIV encoded by *dinB*, have been shown to assist in increased mutagenesis (Tompkins *et al.*, 2003), however, these systems found in *E. coli* are not always directly transposable for mycobacteria. Brooks *et al.* (2001) were the first to show that homologues of *dinP* and *dinX* (homologues of PolIV) were not upregulated after DNA damage induction in *M. tuberculosis*, thereby suggesting that *dinP* is not directly involved in induced mutagenesis. In addition to this Boshoff *et al.* (2003) have confirmed a lack of *dinP* involvement, but confirmed that induced mutagenesis does occur in *M. smegmatis* in a *recA*-dependant manner.

3.2 AIMS AND OBJECTIVES

We needed to determine the point at which DNA damage occurs during UV treatment, since this would introduce the pro-mutagenic lesions necessary to stimulate an SOS response. It was therefore necessary to prepare UV dose response curves. In addition to the wild type *M. smegmatis* mc²155 and L5 phage, the different strains of *M. smegmatis* with deficiencies in genes that have been shown to have putative roles, confirmed regulatory or mechanistic, in the SOS-response were also included. The strains with

deficiencies may have altered sensitivities to UV, therefore these sensitivities needed to be determined as well.

3.3 METHODS

All cultures were grown to OD_{600nm} 0.6 – 0.8, in flasks covered in aluminium foil. The flasks of cultures were kept in foil to minimize the effect of photoinduction and photoreactivation (Sellers *et al* 1970; David, H., 1973).

Cultures that were treated with UV were rinsed twice with warm PBS (37°C) supplemented with Tween 80, prior to UV treatment. A 10ml aliquot of culture was treated in an open Petri dish, under a standard germicidal UV lamp (256nm, dist: ±15cm). After treatment, the cell suspensions were collected and placed in a sterile 50ml disposable polystyrene tube. The cells were then pelleted in a desk-top centrifuge (5mins, 6000rpm) and the pellet resuspended in fresh, warm 7H9 broth (37°C) supplemented with Tween 80.

The L5 phage samples with titres of approximately: $(5.49 \pm 0.92) \times 10^8$ pfu/ml were UV irradiated in 200µl droplets of the phage stock in a Petri dish (conditions as above) followed by dilution series for titration in phage buffer.

The percent survival was calculated for each sample, at each time point. The calculation was as follows:

$$\% \text{ Cell Survival} = \frac{\text{Concentration of Cells After Treatment}}{\text{Concentration of Cells Before Treatment}} \times 100$$

$$\% \text{ Phage Survival} = \frac{\text{Concentration of Phage After Treatment}}{\text{Concentration of Phage Before Treatment}} \times 100$$

3.4 RESULTS

Dose Response for *M. smegmatis* strains to UV Irradiation

The *M. smegmatis* strains were subjected to increasing doses of UV in order to determine the point at which a log-fold decrease in survival occurs. The log fold decrease is indicative of DNA damage (Sander *et al.*, 2001). The respective levels of survival were calculated and plotted for each time point, (see Figure 9, below). The graph shows that the log fold decrease in survival occurs at approximately 20 seconds for all of the *M. smegmatis* cultures except for the *recA* mutant. The *recA* mutant shows a log-fold decrease in survival within 5 seconds of UV treatment. The *dinP* mutant survival curve shows that this mutant is more susceptible to extended UV irradiation (20 to 50 seconds) than the wild type *M. smegmatis* strain.

Dose Response for Mycobacteriophage L5 to UV Irradiation

Since many phage have differing sensitivities to UV irradiation (Kokjohn *et al.*, 1994; Smith and Drake, 1998) it was necessary to determine the point at which our L5 samples experience a log-fold decrease in survival. The phage samples showed a log fold decrease between 5 and 10 seconds of UV treatment, (see Figure 10).

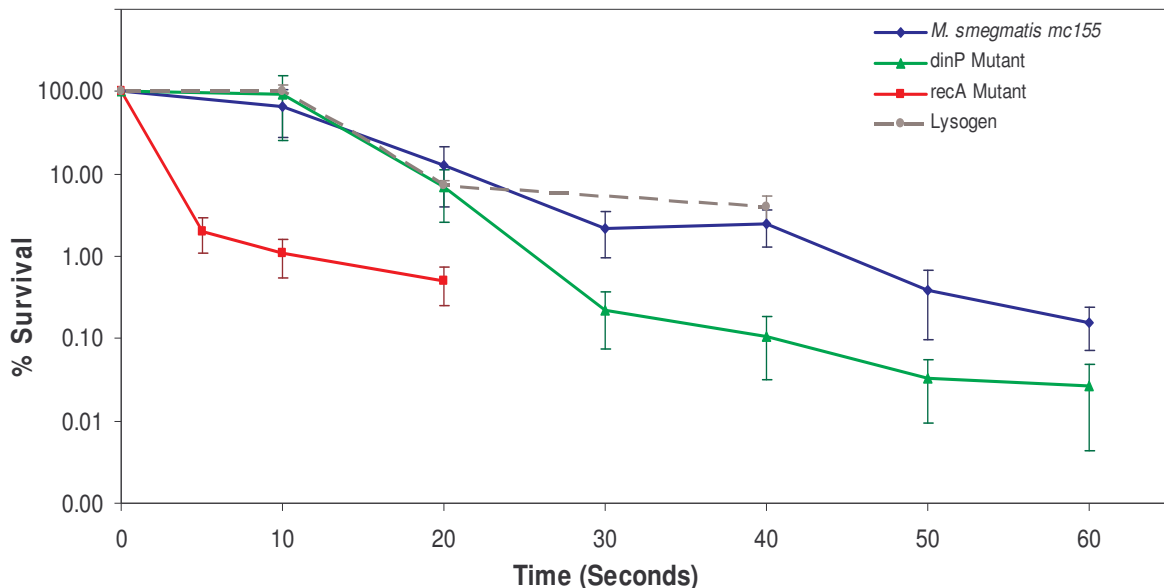

Figure 9. UV Dose Experiments showing the effect of UV irradiation on *M. smegmatis* mc²¹⁵⁵ wild type, L5 Lysogen, *recA* mutant and *dinP* mutant. (Mean values and standard deviations from a minimum of two independent experiments are shown. Appropriate dilutions of each culture were plated out in duplicate, for each experiment.)

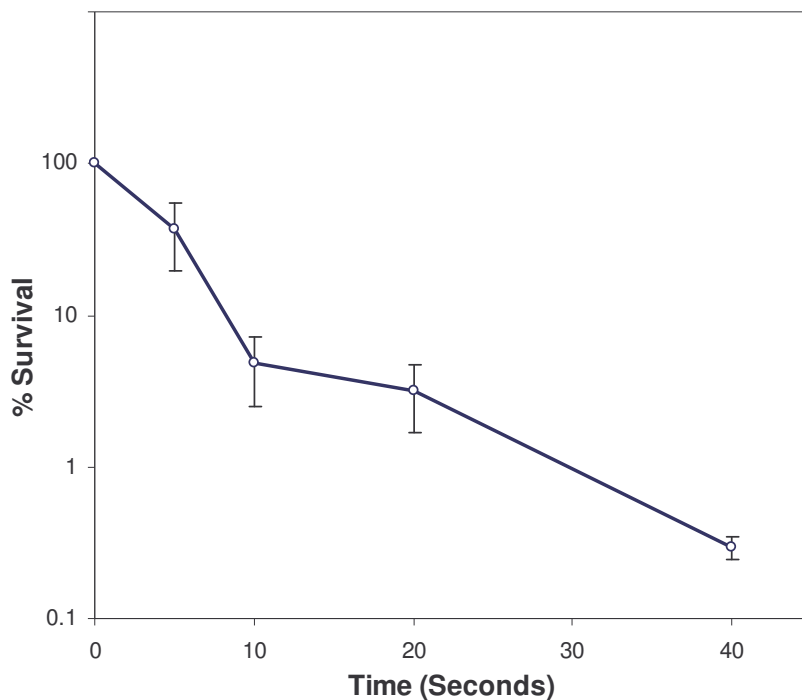

Figure 10. The effect of UV-irradiation on mycobacteriophage L5 survival. (Mean values and standard deviations from two independent experiments are shown. Appropriate dilutions of each phage sample were plated in overlays, in duplicate for each experiment.)

3.5 DISCUSSION AND CONCLUSION

The above data has shown that all the *M. smegmatis* cultures, except the *recA* mutant, undergo a log fold decrease in survival at approximately 20 seconds of UV treatment. Due to the disruption of the *recA* gene which is involved in DNA damage induced mutagenesis (Sander *et al.*, 2001; Boshoff *et al.*, 2003), this mutant is extremely sensitive to UV treatment; hence the log fold decrease in survival occurs in less than 5 seconds of UV exposure. The sensitivity of our *recA* mutant is consistent with data from Papavinasandaram, *et al.* (1998) who showed increased UV sensitivity in a *recA* deletion strain of *M. smegmatis* that was complemented when a cloned *recA* gene was introduced. This data also supports Durbach *et al.* (1997), where it is suggested that the role of *recA* is that of the key regulator of the SOS response.

The decrease in *dinP* mutant survival after extended UV irradiation (20 – 50 seconds) shows that this strain is more sensitive to UV treatment than the wild type *M. smegmatis* strain. This would suggest that the absence of functional DinP directly affects this

strain's ability to survive UV damage and hence supports suggestions that *dinP* may play a role in the SOS response (Kim *et al.*, 1997; Tompkins *et al.*, 2003).

The phage sample is more sensitive to UV than the wild type *M. smegmatis* cells, showing a log fold decrease in survival within 10 seconds of treatment. Kokjohn *et al.* (1995) showed that UV irradiation inactivates different phages at different rates and it has been determined that phage can undergo photoreactivation which would lead to increased survival after UV exposure (reviewed in Rado and Bates, 1980). Mycobacteriophage D29 has been shown to be more sensitive than *M. smegmatis* to UV irradiation (David, 1973). Since D29 and L5 are very closely related, those results (David, 1970) support the level of UV sensitivity seen for our L5 sample.

The time points at which each of these samples has undergone a log fold decrease in survival will be used in the DNA damage-induced mutagenesis experiments since this will ensure that the systems will most likely have acquired DNA damage (Sander *et al.*, 2001).

CHAPTER FOUR - DETERMINATION OF THE CLEAR PLAQUE MUTANT FREQUENCY IN RESPONSE TO DNA DAMAGING TREATMENTS

4.1 INTRODUCTION

Mechanisms for the Detection of DNA Damage

Many methods to detect DNA damage and mutation have been developed. These methods range from direct analysis of damaged DNA to forward mutation assays and phage-based detection systems. These systems rely either on isolated DNA, thereby rendering the cell non-viable; or viable cells that undergo a change in resistance to a chemical or antibiotic; or cells that when infected with a phage, the phage undergoes a change in plaque morphology due to DNA damage.

Early methods to detect DNA damage at a molecular level relied on the use of radioactivity (reviewed in Sinha and Häder, 2002). These systems require the incorporation of radioactive nucleotides into the target DNA. DNA damage and degradation could then be detected by a decrease in the percentage of the overall radioactivity (Sinha and Häder, 2002). Although radioactive techniques can be applied successfully, non-radioactive techniques are advantageous due to their relative ease of use.

The earlier non-radioactive DNA damaging experiments focused on determining the levels of pyrimidine dimer formation by utilizing lesion-specific endonucleases (Freeman *et al.*, 1986). The enzyme T4 endonuclease V recognises and breaks DNA strands at the sites of pyrimidine dimers (Seawell *et al.*, 1980). The resulting DNA can then be separated electrophoretically by alkaline agarose gel electrophoresis to determine the relative levels of DNA damage (Freeman *et al.*, 1986). Thomas *et al.* (1989) utilized an *E. coli* ABC excinuclease that recognises many types of DNA lesions in conjunction with a photolyase to determine the levels of (6-4) photoproducts, which are a form of DNA damage distinct to the traditional pyrimidine dimers.

More recent attempts to determine levels of DNA damage have used antibody detection of specific dimer formations (Sinha *et al.*, 2001; Boelen *et al.*, 2001). Primary antibodies,

specific to the dimer of interest, are used as a probe followed by a secondary antibody which is generally linked to a fluorescein component, thereby allowing for the visual determination of the existence of damage. These immuno-dot-blot techniques have allowed for the quantification of the level of DNA damage sustained within a cell by direct comparison of the test blot against reference curves of known damage exposures (Sinha *et al.*, 2001; Klisch *et al.*, 2005).

The procedures described above have limited their DNA damage detection to one specific DNA damage product, however, recent techniques utilizing high performance liquid chromatography (HPLC) coupled with mass spectrometry (MS) have proved to be far more elegant (Douki *et al.*, 2000). These techniques are sensitive enough to distinguish between the four forms of thymine dimers. All the techniques described thus far, including HPLC-MS, rely on the destruction of the cell containing the damaged DNA and hence are direct methods for determining DNA damage. Techniques that require viable cells for damage detection have included the use of forward mutation markers (generally antibiotic resistances) to determine the overall level of DNA damage and therefore the level of mutation that an organism is undergoing. These systems are indirect processes of assessing DNA damage through mutation detection.

Forward mutation markers rely on mutational processes that alter an organism's phenotype in response to a mutation, which often occurs during moments of cell stress and under DNA damaging conditions, through the acquisition of a pro-mutagenic lesion (see Chapter 3, Introduction). Since an altered phenotype is the discerning feature for the determination of elevated rates of mutation in these systems, it is possible to study viable cultures, therefore by-passing the necessity for direct analysis at the molecular level. Both antibiotic and mutagen resistances have been utilized as forward mutation markers in a variety of bacterial species, e.g. *S. typhimurium* (Skopek *et al.*, 1978) and *E. coli* (Bosworth *et al.*, 1987; Rangarajan *et al.*, 1997).

Although antibiotic/mutagen resistances as forward mutation markers are sensitive and well described, these systems often rely on the use of potentially hazardous chemicals.

The phage-based system for determining host mutational levels is however, a well established technique dating back to the early phage workers such as Weigle (1953). This system relies on phage plaque morphology as a method for determining/assessing the levels of potential DNA damage and mutation induction (see Figure 1, Chapter 1) which is done by visual comparison of normal ‘turbid’ plaques with mutant ‘clear’ plaques. The system has been successfully used in *E. coli* using both bacteriophage λ (Kondo and Ichikawa, 1973; Kim *et al.*, 1997; Wagner and Nohmi, 2000) and Φ X174 (Bleichrodt and Verheij, 1974). Phage λ has been used as a probe for many cellular mutagenic processes and this system has allowed for the elucidation of *recA*, *dinB* and *umuDC* function in *E. coli* (Brotcorne-Lannoye and Maenhaut-Michel, 1986; Wagner and Nohmi, 2000). This phage system has proved to be one of the few systems currently available that allows for the detection of untargeted mutagenesis without having to overexpress host mutator genes (Kim *et al.*, 1997) or perform direct DNA analysis (Sinha and Häder, 2002).

Although the phage system is well established in *E. coli* it has not been explored for mycobacterial species. Mycobacteriophage L5 is a lysogenic phage for *M. smegmatis* and *M. tuberculosis* and possesses a repressor protein Gp71, which is similar to the cI repressor in phage λ . Both *E. coli* and *M. tuberculosis* possess a functional SOS response that is governed by RecA function, even though the SOS induced genes in each host differ significantly (see Introduction, Chapter 3). Based on the similarities between λ and L5 and *E. coli* and *M. smegmatis* we intended to determine the efficacy of mycobacteriophage L5 as a marker for mutation induction in mycobacteria.

4.2 AIMS AND OBJECTIVES

In order to determine the levels of mutation induction under UV damaging conditions (determined in Chapter 3), the DNA damaging systems need to be carried out using mycobacteriophage L5 and *M. smegmatis* mc²155. Various mutants that have been shown and/or are suspected to be involved in induced mutagenesis were included in the study. We also decided to test the levels of mutation induction within the L5 lysogen. It is known that UV treatment of a lysogen may induce lysis, however L5 lysogens have been shown to be only mildly inducible by UV irradiation.

4.3 METHODS

The mutant induction experiments for gathering CPM frequency data follow the schematic outline in Figure 11, on page 49. All cultures were grown to OD_{600nm} 0.6 - 0.8 and were covered in foil during incubation in order to prevent photoinduction and photoreactivation (Sellers *et al* 1970; David, H., 1973).

Mutation Induction Experiments: Cultures that were to be UV treated were grown to an OD_{600nm} of 0.6 - 0.8. The cultures were then washed twice with PBS-Tween80 (37°C) in order to remove all traces of growth media prior to UV irradiation. A 10ml aliquot of the wild type cultures and the *dinP* mutant were UV irradiated for 20 seconds, where as the *recA* mutant was treated for 4 - 5 seconds, as described in Chapter 3. After irradiation the cultures were spun down in a desktop centrifuge at 7000rpm, 5 minutes. The pellets were then resuspended in Middlebrook 7H9 broth supplemented with 0.04% Tween 80. Mycobacteriophage L5 was UV treated for 10 seconds, as described in Chapter 3. Adsorption of L5 to the *M. smegmatis* cells was carried out at 37°C, for 10 minutes with intermittent gentle shaking to ensure even phage distribution. After adsorption, the free phage was inactivated using an end concentration of 10mM FAS as determined in Chapter 2, followed by a 1:100 dilution in growth media. FAS treatment ensures that only phage that are adsorbed onto or injected into the host are allowed to pass through the induction system. Three aliquots (5ml) of the diluted sample were layered onto amplification plates and incubated overnight at 37°C. Amplification plates are indicator plates prepared with added calcium chloride. When these plates are overlaid with

phage containing media they serve to amplify the present phage in the media, through the transfection of the sensitive cells in the indicator agar. Following incubation the remaining fluid was drained from the surface of the amplification plates into a 50ml centrifuge tube and the debris was pelleted at 3500rpm, 5minutes, in a desktop centrifuge. The supernatant was titrated for overall pfu.ml⁻¹ and CPM.ml⁻¹ such that the end calculation of the CPM frequency for each treatment point could be carried out. The calculation for CPM Frequency was:

$$\text{CPM Frequency} = \frac{\text{Concentration of CPM's in the sample}}{\text{Concentration of Overall PFU's in the sample}}$$

L5 Lysogen Mutation Induction Experiment: The lysogen culture was grown to an OD_{600nm} of 0.6 - 0.8, as described above. The culture was rinsed twice with PBS-Tween 80 (37°C) and FAS added to an end concentration of 10mM in order to remove free phage prior to treatment. This process ensures that the progeny phage resulting from the experiment have arisen from within the lysogen. A 10ml aliquot of the culture was then UV irradiated for 0 seconds, 10 seconds and 20 seconds. After UV irradiation, the culture was rinsed and resuspended in 10ml Middlebrook 7H9 broth supplemented with 0.04% Tween 80 and incubated at 37°C with gentle shaking. Samples were removed from the cultures at various intervals and titrated in order to calculate the CPM Frequency, as described in the previous section.

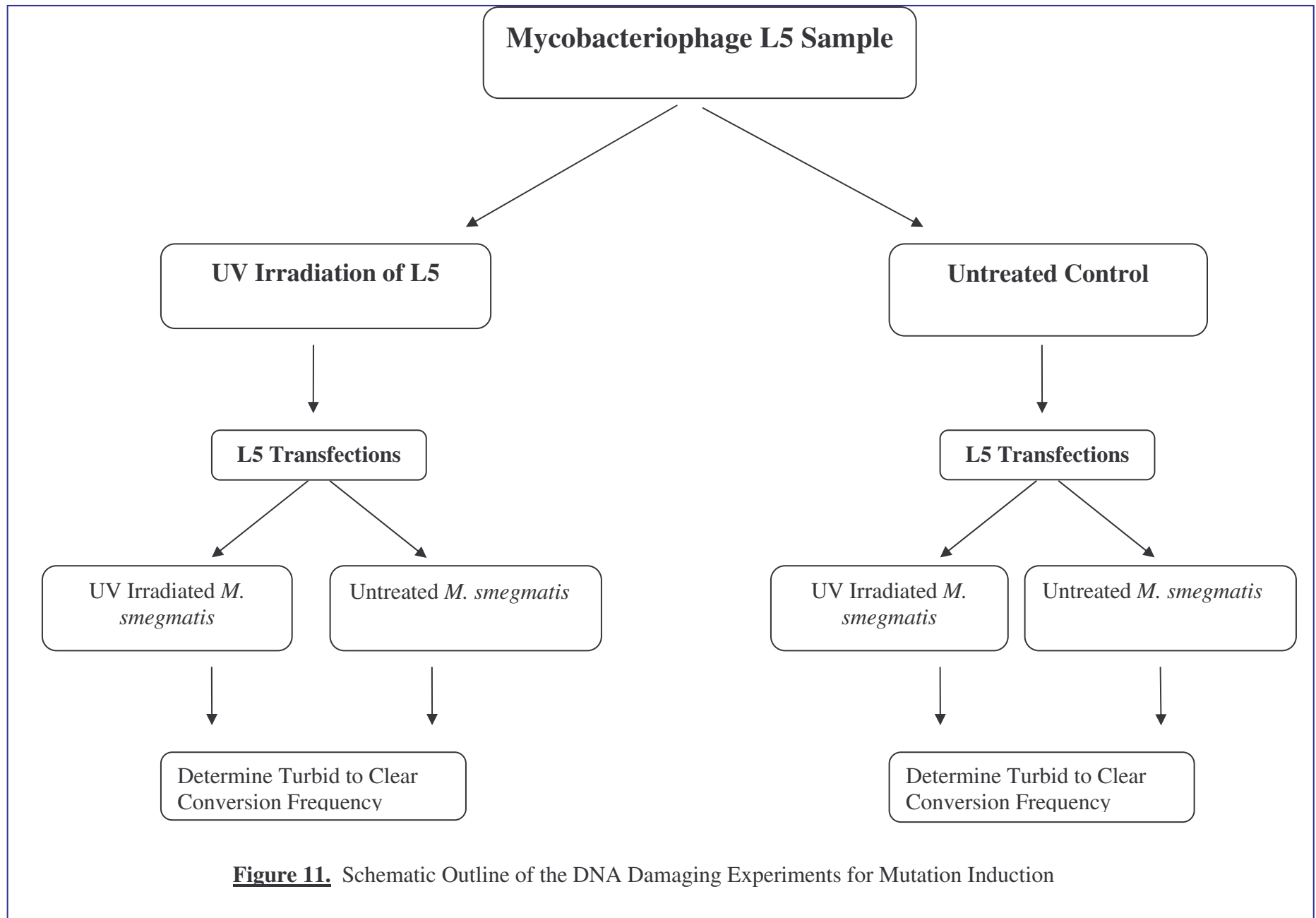

4.4 RESULTS

Given the overall similarities between phage λ and mycobacteriophage L5, and that *M. smegmatis* has the regulatory signals to mount an SOS response, as well as that it has been found to respond to induced mutagenesis, we reasoned that transfection of L5 into UV-treated *M. smegmatis* cells should lead to an increase in CPM frequency. We also hypothesized that the UV-treatment of L5 prior to transfection should lead to an enhanced CPM frequency since it will provide DNA lesions on which the cells mutagenic processes can work.

Figure 12 below, shows the data gained from the mutant induction assay performed on wild type *M. smegmatis* mc²155. When untreated phage (Figure 12A) is transfected onto UV treated cells the CPM frequency increases slightly (~ 4-fold), yet noticeably, when compared to untreated cells. This result suggests that UV irradiation of the host cells ‘primes’ or induces these cells to act on an undamaged phage DNA template, thereby increasing the overall CPM frequency.

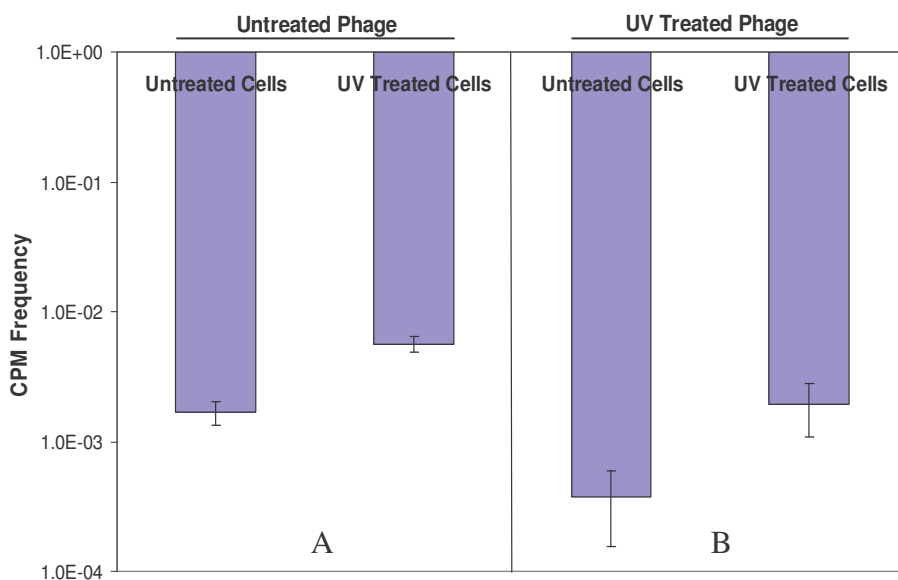

Figure 12. Mutant Induction Assay for wild type *M. smegmatis* mc²155. UV irradiation was used as the DNA damaging method (*M. smegmatis*: 20seconds; Mycobacteriophage L5: 10seconds). The data represents the average of two independent experiments, each with internal duplicates. (Multiplicty of Infection (MOI): 8.61)

When comparing UV treated phage (Figure 12B) transfected onto UV treated host cells against untreated host, a slight increase (~ 3-fold) in CPM frequency can again be seen. This result suggests that the UV irradiation of the *M. smegmatis* cells indirectly causes an increase in the rate of mutation of transfected phage L5.

It can be seen that when UV treated phage is transfected onto untreated host (Figure 12B) the resulting CPM frequency is markedly less (~ 4-fold) than that obtained for untreated phage transfected on untreated host (Figure 12A). This result suggests that the untreated (uninduced) host cells are capable of repairing the DNA lesions present on the incoming phage genome.

Given that the untreated phage showed a low, but noticeable, elevation of CPM frequency in a treated host, we assessed if this effect could be linked to a cellular process, the SOS response. Since *recA* has been shown to be the primary controller of the SOS response (which is stimulated after a cell has undergone DNA damaging treatment such as UV irradiation) we explored the phage system on the *M. smegmatis recA* mutant. Figure 13, following page, shows the CPM frequency data gathered from the *recA* mutant system. When the host cells were UV irradiated the CPM frequency drops significantly (just less than a 10-fold reduction). This finding suggests that the SOS system may be directly responsible for the elevation of untargeted mutagenesis, seen in Figure 12.

Since the data shown in Figure 13 supports the suggestion that the RecA-mediated SOS system is responsible for untargeted mutagenesis, it was decided to test the phage system using a *dinP* mutant of *M. smegmatis*. This strain was chosen due to conflicting data with regards to the role of *dinB* in the SOS response and hence untargeted mutagenesis. In *E. coli*, *dinB* has been shown to play an active role in untargeted mutagenesis (Kim *et al.*, 1997; Wagner and Nohmi, 2000) however, in *M. tuberculosis dinP* (a homologue of *dinB*) does not seem responsible or involved in induced mutagenesis in this bacterial family (Brooks *et al.*, 2001).

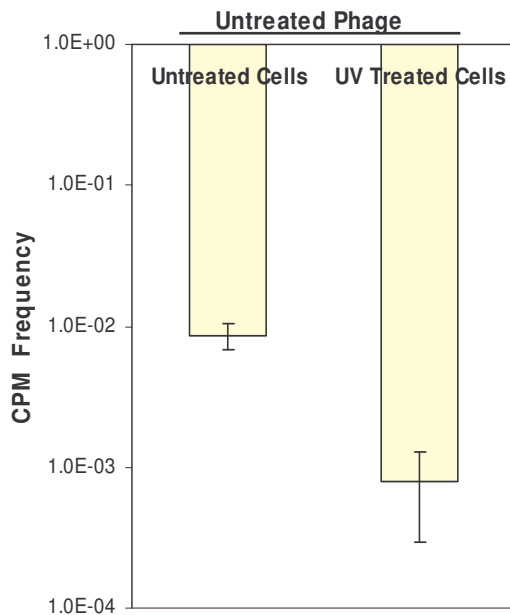

Figure 13. Mutant Induction Assay for *M. smegmatis recA* Mutant. The *recA* mutant was UV irradiated for 5 seconds and the L5 phage sample for 10 seconds. The data above represents one experiment, performed within internal duplicates.

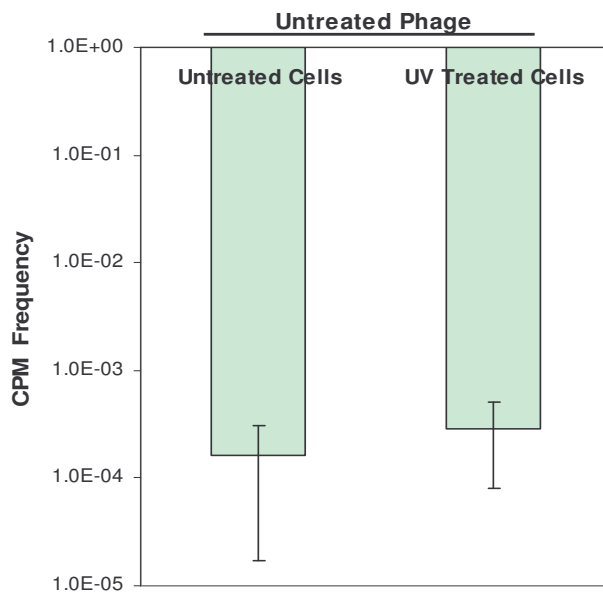

Figure 14. Mutant Induction Assay for the *M. smegmatis dinP* Mutant. The *dinP* cultures were UV irradiated for 20 seconds and the L5 phage samples for 10 seconds. The data represents the average of two independent experiments, each with internal duplicates.

The *dinP* data, (see Figure 14), shows that the absence of functional DinP does not seem to directly affect the CPM frequency when the host cells are UV irradiated. The difference between the CPM frequencies for both untreated and UV irradiated host cells does not show any noticeable increase or decrease. This would suggest that the absence of functional *dinP* results in a decreased SOS response, since the levels of untargeted mutagenesis did not increase. The CPM frequency did not show a dramatic reduction when the cells were UV treated, unlike the *recA* data; suggesting that *dinP* may play a role in the *M. smegmatis* SOS response, however the role it plays is not as critical as that of *recA*.

Since the UV irradiation of the phage samples (Figure 12B) did not lead to an increased CPM frequency greater than the untreated phage samples (Figure 12A), we reasoned that it was possible that the UV irradiation was not permeating through to the phage genomes. We then hypothesized that UV irradiation of a lysogen would ensure that the host as well as the prophage genome would be damaged since they exist together within the cell. UV irradiation of a lysogen would either cause prophage induction (which occurs only mildly in L5 lysogens – Donnelly-Wu *et al*, 1993) or would cause DNA damage to both the host and incorporated phage genomes. The L5 lysogen UV mutant induction system produced relatively static data (see Figure 15, on the following page). The data is consistent for both UV irradiated samples irrespective of treatment period and both are in turn similar to the untreated lysogen, showing no noticeable variation. The samples did not show any variation in CPM frequency with respect to sampling times.

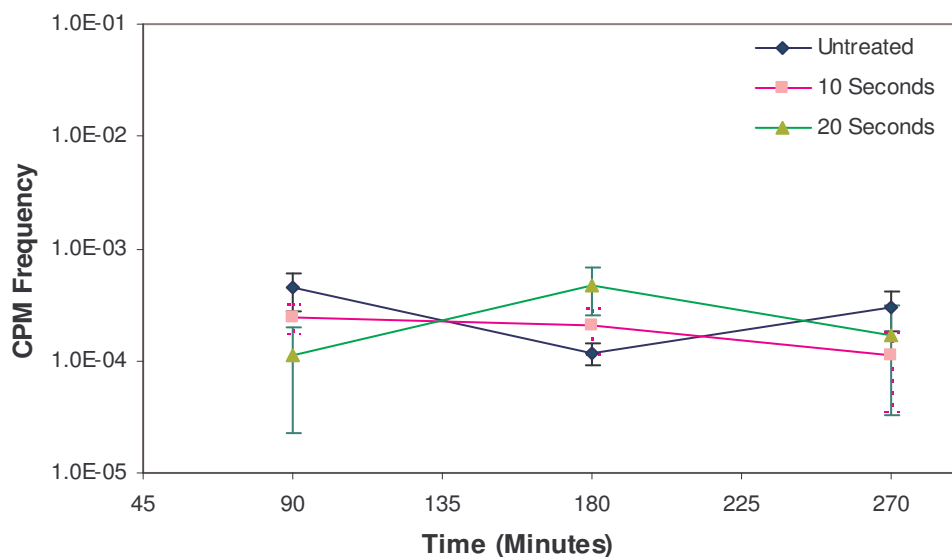

Figure 15. Mutant Induction in the L5 Lysogen after Increasing Exposure to UV Irradiation. Samples were removed from the treated culture at 90min, 180 min and 270 min. The data represents the average of two experiments, each performed with internal duplicates.

4.5 DISCUSSION

In order to assess the efficacy of a phage based mutation induction assay, wild type *M. smegmatis* mc²155 was transfected with mycobacteriophage L5, with or without a DNA damaging pre-treatment. The results have shown that when *M. smegmatis* cells are UV irradiated prior to phage transfection, an elevated CPM frequency results. Since the L5 phage sample had not been UV irradiated, the resulting mutations must have originated through host cell mechanisms. Similar results have been shown for the mutagenesis of phage λ in *E. coli* where the SOS response genes have been examined for possible mutator activity (Kim *et al.*, 1997; Wagner and Nohmi, 2000). Our data suggests that we have shown the first demonstration of *M. smegmatis* mc²155's ability to perform untargeted mutagenesis on phage DNA in response to the presence of cellular DNA damage.

Since an increase in CPM frequency results when untreated phage are transfected onto UV treated cells, it was necessary to explore the effect of transfecting with damaged phage, since we reasoned that this would amplify the mutant induction signal. Our results show a slight increase in CPM frequency when UV treated phage are transfected

onto UV treated cells rather than untreated cells. This increase in CPM frequency may again be attributed to untargeted mutagenesis - since the both the phage samples were UV treated, the levels of targeted mutagenesis (through the action of a low fidelity translesion synthesis mechanism) should be constant between to the two samples, leaving untargeted mutagenesis as a possible source for the increased mutation frequency.

We hypothesized that *M. smegmatis*' ability to carry out error-prone translesion synthesis could be assessed through the comparison of the resulting CPM frequencies obtained from untreated cells transfected with either untreated or treated phage. Here, where the treated phage are transfected onto untreated host cells, a marked decline in mutant frequency can be seen. This result is similar to that found by Weigle (1953) with phage lambda and *E. coli*, where no CPMs were gathered irrespective of the level of phage survival after UV treatment. There are two possible explanations for the phenomenon we have demonstrated. Firstly, untreated *M. smegmatis* cells may be capable of correcting all the UV induced lesions on the incoming phage genome in an error free manner- thereby returning the overall CPM frequency to untreated levels and perhaps lower. The second alternative is that the phage genomes may experience something akin to error catastrophe (Summers and Litwin, 2006) - since the host *M. smegmatis* was not 'primed' through UV treatment to cope with the level of DNA damage present on the phage genomes, the cells could not save the phage from the errors that were present, thereby resulting in an overall decreased CPM frequency (Negishi *et al.*, 2002). Since it is known that *M. smegmatis* has elements of a functional translesion synthesis (TLS) system that is governed by the presence of damaged DNA templates (Boshoff *et al.*, 2003), and that TLS is notoriously error-prone (Livneh, 2001), the first explanation can not be plausible since TLS would result in an increased CPM frequency. We suggest that the CPM frequency decreases possibly due to error catastrophe due to UV irradiation.

Although we did not show an increase in CPM frequency when we supplied a damaged phage template to an untreated cell, we were able to demonstrate untargeted mutagenesis.

This process of mutagenesis has been shown to be primarily governed by the SOS response (Boshoff *et al.*, 2003) which is stimulated when RecA binds to single stranded DNA resulting from stalled replication forks. Since RecA is pivotal to the functionality of the SOS response, we explored whether applying the phage system to a *recA* deletion strain of *M. smegmatis* mc²155 would abrogate the effect of untargeted mutagenesis. The data shows a clear reduction in CPM frequency and hence untargeted mutagenesis for this *recA* mutant. The reduced CPM frequency suggests that the *recA* mutant cells are incapable of rescuing phage genomes that may possess DNA damage, resulting in fewer CPMs since the host untargeted mutagenesis systems are dysfunctional. Hence, this data supports evidence that RecA is the key activator of the SOS response (Durbach *et al.*, 1997).

Since our data supports evidence of a mycobacterial SOS response controlled by *recA* it was decided that the putative role of *dinP* as a mutator should be tested in the phage system. Although *dinP/B* homologues have been shown to have mutator roles in *E. coli* (Tompkins *et al.*, 2003), data obtained from other recent findings (Brooks *et al.*, 2001; Boshoff *et al.*, 2003) suggest that mycobacterial homologues of *din* do not assist in SOS induced mutagenesis. Our *dinP* data revealed no increase in CPM frequency when the cells were UV irradiated. If *dinP* did not play any role in the mycobacterial SOS response, we would expect the UV irradiated cells to mirror wild type *M. smegmatis* and exhibit an elevated CPM frequency since the absence of *dinP* would not have affected the CPM frequency. However, our *M. smegmatis dinP* mutant and L5 phage system did not show any increase in CPM frequency when the cells were UV irradiated. This data suggests that this gene does play a role in the mycobacterial SOS response and its absence results in decreased levels of untargeted mutagenesis.

Our data has shown that the L5 phage system for determining levels of induced mutagenesis is robust enough to indicate whether or not a culture is capable of mutagenesis. Perhaps, after further optimization, the system may become sensitive enough to determine the exact levels of induced mutagenesis that a culture may sustain. We hypothesized that a lysogenic culture for L5, which contains phage in their prophage

state, may provide a more sensitive system for mutant induction because the phage genome is more likely to be damaged following UV irradiation. When the mutant induction system was applied to the L5 lysogen, no remarkable changes in CPM frequency could be determined. Although two different levels UV irradiation were used and samples for CPM analysis were taken over a three hour sampling period, no discernable difference in CPM frequency could be detected. The L5 lysogen system seems extremely resistant to mutagenesis and hence unsuitable for mutant induction assays.

4.6 CONCLUSION

Although the L5 lysogen system proved to be insensitive to detecting mutation induction, the wild type *M. smegmatis* mc²155 system could detect a slight, yet noticeable, increase in untargeted mutagenesis. This implies that the UV irradiated cells were directly responsible for the mutagenesis of the undamaged phage templates. The presence of untargeted mutagenesis has been linked to the activation of the SOS response, which was confirmed with our *recA* mutant data. The *dinP* mutant system supports research that suggests that this *din* homologue may play a role in mycobacterial error prone DNA repair. In addition to this, evidence that functional RecA is responsible for switching on the SOS response in mycobacteria, is supported by our *recA* data.

Our data suggests that this L5 phage system could be applied to mycobacterial cultures to determine the ability of these cultures to perform untargeted mutagenesis. However, further research is required to amplify the signal of induced mutagenesis such that the level of induction may be accurately measured. A system also needs to be developed to determine if the phage DNA is being damaged through UV irradiation, and if so, at what level.

CHAPTER FIVE – CONCLUDING REMARKS

Our research aim was to determine whether mycobacteriophage L5 could be used as a marker for mutation induction in *M. smegmatis*. The culmination of the data developed for this research project is a recommendation that with further research and optimization, a mycobacteriophage (not necessarily L5) could potentially be used with this intention. The following is a summary of the results achieved as well as concluding remarks.

Since many of the mycobacteriophages known to date are similar in both structure and plaque morphology, it was necessary to develop tools to confirm the purity of our phage samples. Mycobacteriophage L5 protocols have been optimised and restriction digests performed in order to confirm the identity of the L5 phage samples. We have found that the use of cesium chloride gradient centrifugation followed by dialysis has proved to yield pure, high titre phage stocks which can be readily utilized in DNA damaging experiments.

Prior to conducting the DNA damage induction experiments, it was necessary to establish the levels at which the strains used in this study (wild type mc²155; *recA* mutant; *dinP* Mutant; L5 lysogen) and the L5 phage were most likely sustaining DNA damage following exposure to UV irradiation. UV dose response survival curves were created for each of the samples. The wild type *M. smegmatis* mc²155, *dinP* mutant and the L5-lysogen showed a log-fold decrease in survival after 20 seconds of UV irradiation. We also noted that at seconds, the *dinP* mutant's sensitivity to UV was elevated when compared to the wild type strain. The *recA* mutant and L5 phage samples were extremely sensitive to UV and showed log-fold decreases within 5 and 10 seconds of UV irradiation respectively. The levels of UV irradiation which resulted in a log-fold decrease in survival were used in the mutant induction experiments. The success of the mutant induction experiments relied on the ability to isolate a clear plaque mutant (CPM) of L5 and since it was not possible to isolate the CPMs without background wild type phage contaminating the sample, putative CPMs were identified in a screening technique that utilizes an *M. smegmatis* – L5 lysogen. With the development of our CPM

screening system and the data from the UV dose survival curves, it was possible to implement and optimise the mutant induction assays.

The wild type *M. smegmatis* and L5 mutant induction system showed low, yet noticeable, levels of untargeted mutagenesis. It was believed that the mutagenesis seen was directly linked to the host SOS response, which under these circumstances would have been induced through the UV irradiation of the cells. In order to explore the involvement of the SOS response in the untargeted mutagenesis of L5 we applied the mutant induction system to a *recA* mutant culture. Our data has shown that without the presence of functional RecA the activity of the SOS system is reduced and the relative CPM frequency does not increase. This data suggests that *recA* activity is directly linked with increased CPM frequency and hence the untargeted mutagenesis seen in the wild type culture is likely to be due to the effect of the SOS response.

Since we have indirectly shown that *M. smegmatis* has a functional SOS response that is governed by the presence of functional RecA protein and damaged DNA, we decided to explore the effect of a *dinP* mutant. *DinP* has been shown to be induced with the SOS response in *E. coli* however, its role in *M. smegmatis* has not been clearly defined. We reasoned that if *dinP* was not required for SOS induction, UV irradiation of the *dinP* mutant would mimic wild type *M. smegmatis* and result in increased CPM frequency. Since no elevation in CPM frequency was detected with the *dinP* mutant strain, our data suggests that *dinP* may have a slight involvement in the mycobacterial SOS response. The involvement of *dinP* in the SOS response does not seem to be at the same regulatory level as *recA* since we did not see a dramatic reduction of CPM frequency with the *dinP* mutant.

Our mutant induction system has shown an increase in mutant frequency related to untargeted mutagenesis but the levels of mutant induction seen were low. We hypothesized that by pre-treating the phage with UV irradiation we would i) supply a damaged DNA template which would elevate the basal levels of RecA functioning thereby switching on the SOS response, albeit at low levels, and ii) provide a damaged

template which obviously already holds DNA lesions caused by the UV treatment and the presence of these lesions should lead to an increased mutant frequency due to the action of both targeted and untargeted mutagenesis. When the phage samples were UV treated a lower initial CPM frequency (compared to untreated phage and untreated cells) was achieved which is in contrast to what was expected. These findings were unexpected and can not be explained fully.

We reasoned that since an *M. smegmatis* (L5) lysogen contains a prophage inserted within the host genome, UV irradiation of a lysogen culture would cause DNA damage to both the host genome and prophage. Since this process would ensure that targeted mutagenesis of the phage genome would occur we further reasoned that an amplified mutant signal should occur. The lysogen induction system however revealed static results over numerous repeats, with no discernable increase in CPM frequency.

These unexpected findings allowed us to re-evaluate our level of understanding with regards to mycobacteriophage L5. Mycobacteriophage L5 is a fairly ‘recently’ discovered phage and the level of research done on this phage pales in comparison to that done on phage λ . Our understanding of phage L5’s infection dynamics are poor and assumptions can only be made by drawing comparisons with other unrelated coli phage. We suggest that the unusual data gained from our attempts to create an amplified mutagenesis signal may be due to unknown phage-host interactions. Phage T4 has been shown to possess its own damage repair genes which allow it to use host resources to repair damage sustained by its own genome (Bernstein, C., 1981). Since so little is known with regards to mycobacteriophage recovery in their hosts, it is quite possible that a system, similar to that shown in T4, may be present in mycobacteriophage L5. Mycobacteriophage L5 has been shown to possess its own DNA polymerase as well as a gene that is similar to the T4 endonuclease VII (Hatfull, 2001; Raaijmakers *et al*, 1999), thereby suggesting that L5 may possess features which allow it to affect the repair of its own genome.

Although our understandings of the mycobacteriophage-host interactions are extremely limited we have been able to demonstrate an increase in induced mutagenesis in response to DNA damage. Based on our findings we suggest that further research is required with regards to phage-host interactions and that perhaps optimisation of the mutant induction assay may in the future provide a system that could be used as an effective mutation marker for mycobacteria.

REFERENCES

- Ackermann, H.W.** 2001. Frequency of morphological phage descriptions in the year 2000. *Archives of Virology*. **146** (5): 843 – 857
- Adams, M.H.** 1952. Classification of Bacterial Viruses: Characteristics of the T5 Species and of the T2, C16 Species. *Journal of Bacteriology*. **64**: 387 - 396
- Adams, M.H. and Wade, E.** 1954. Classification of Bacterial Viruses: The Relationship of Two Serratia Phages to Coli-Dysentery Phages T3, T7, and D44. *Journal of Bacteriology*. **68**: 320 – 325
- Aertsen, A., Van Houdt, R., Vanoirbeek, K. and Michiels, C.W.** 2004. An SOS Response Induced by High Pressure in *Escherichia coli*. *Journal of Bacteriology*. **186** (18): 6133 – 6141
- Barksdale, L. and Kim, K.** 1977. *Mycobacterium*. *Bacteriological Reviews*. **41** (1): 217 - 372
- Bernstein, C.** 1981. Deoxyribonucleic Acid Repair in Bacteriophage. *Microbiological Reviews*. **45** (1): 72 – 98.
- Bleichrodt, J.F and Verheij, W.S.** 1974. Mutagenesis by UV Radiation in Φ X174: on the Mutation Stimulating Processes Induced by UV Radiation in the Host Bacterium. *Molecular General Genetics*. **135**: 19 – 27.
- Bobadilla-del-Valle, M., Ponce-de-Leon, A., Arenas-Huertero, C., Vargas-Alarcon, G., Kato-Maeda, M., Small, P., Couary, P., Ruiz-Palacios, G. and Sifuentes-Osornio.** 2001. *rpoB* Gene Mutations in Rifampicin-Resistant *Mycobacterium tuberculosis* Identified by Polymerase Chain Reaction Single Stranded Conformational Polymorphism. *Emerging Infectious Diseases* **7** (6): 1010-1013
- Boelen, P., Veldhuis, M. and Buma, A.** 2001. Accumulation and removal of UVBR-induced DNA damage in marine tropical plankton subjected to mixed and simulated non-mixed conditions. *Aquatic Microbial Ecology*. **24**:265 - 274
- Boshoff, H., Durbach, S. and Mizrahi, V.** 2001. DNA Metabolism in *Mycobacterium tuberculosis*: Implications for Drug Resistance and Strain Variability. *Scandinavian Journal of Infectious Disease*. **33**: 101 – 105
- Boshoff, H., Reed, M.B., Barry III, C.E. and Mizrahi, V.** 2003. DnaE2 Polymerase contributes to In Vivo Survival and Emergence of Drug Resistance in *Mycobacterium tuberculosis*. *Cell*. **113**: 183 – 193

- Bosworth, D., Crofton-Sleigh, C. and Venitt, S.** 1987. A Forward Mutation Assay Using Ampicillin-Resistance in *Escherichia coli* Designed for Investigating the Mutagenicity of Biological Samples. *Mutagenesis*. **2**: 455 – 467
- Bowman, B.U.** 1958. Quantitative Studies on some Mycobacterial Phage-Host Systems. *Journal of Bacteriology*. **76**: 52 – 62
- Bradley, D.E.** 1967. Ultrastructure of Bacteriophages and Bacteriocins. *Bacteriological Reviews*. **31** (4): 230 – 314
- Brooks, P.C., Movahedzadeh, F. and Davis, E.O.** 2001. Identification of Some DNA Damage-Inducible Genes of *Mycobacterium tuberculosis*: Apparent Lack of Correlation with LexA Binding. *Journal of Bacteriology*. **183** (15): 4459 - 4467
- Brotcorne-Lannoye, A. and Maenhaut-Michel, G.** 1986. Role of RecA Protein in Untargeted UV Mutagenesis of Bacteriophage Lambda: Evidence for the Requirement for the *dinB* Gene. *Proceedings of the National Academy of Science, USA*. **83**: 3904 – 3908
- Brown, K., Sarkis, G., Wadsworth, C. and Hatfull, G.** 1997. Transcriptional silencing by the mycobacteriophage L5 repressor. *The EMBO Journal*. **16**: 5914-5921
- Cole, S., Brosch, R., Parkhill, J., Garnier, T., Churcher, C., Harris, D., Gordon, S., Eiglmeier, K., Gas, S., Barry, C., Tekaia, F., Badcock, K., Basham, D., Brown, D., Chillingworth, T., Connor, R., Davies, R., Devlin, K., Feltwell, T., Gentles, S., Hamlin, N., Holroyd, S., Hornsby, T., Jagels, K., Krogh, A., McLean, J., Moule, S., Murphy, L., Oliver, K., Osborne, J., Quail, M., Rajandream, M., Rogers, J., Rutter, S., Seeger, K., Skelton, R., Squares, R., Squares, S., Sulston, J., Taylor, K., Whitehead, S. and Barrell, B.** 1998. Deciphering the biology of *Mycobacterium tuberculosis* from the complete genome sequence. *Nature*. **393**: 537 - 544
- Corbett E.L., Watt, C.J, Walker, N., Maher, D., Williams, B.G., Raviglione, M.C. and Dye, C.** 2003. The Growing Burden of Tuberculosis. *Archives of Internal Medicine*. **163**: 1009 - 1021
- Datta, H., J. and Mandal, N.C.** 1998. Identification of an early positive regulatory gene of mycobacteriophage L1. *Journal of General Virology*. **79**: 205-210
- David, H.L.** 1973. Response of Mycobacteria to Ultraviolet Light Radiation. *American Review of Respiratory Disease*. **108**: 1175 – 1184.
- Defais, M., Fauquet, P., Radman, M. and Errera, M.** 1971. Ultraviolet Reactivation and Ultraviolet Mutagenesis of λ in Different Genetic Systems. *Virology*. **43**: 495 - 503
- Delbrück, M.L.** 1945. Effects of Specific Antisera on the Growth of Bacterial Viruses (Bacteriophages). *Journal of Bacteriology*. **50** (2): 137 – 150.

- Donnelly-Wu, M., Jacobs, W. and Hatfull, G.** 1993. Superinfection Immunity of Mycobacteriophage L5: Applications for Genetic Transformation of Mycobacteria. *Molecular Microbiology* **7**: 407 - 417
- Douki, T., Court, M, Sauvaigo, S., Odin, F. and Cadet, J.** 2000. Formation of th Main UV-Induced Thymine Dimeric Lesions within Isolated and Cellular DNA as Measured by High Performance Liquid Chromatography-Tandem Mass Spectrometry. *Journal of Biological Chemistry*. **275 (16)**: 11678 – 11685
- Dulbecco, R.** 1950. Experiments on Photoreactivation of Bacteriophages Inactivated with Ultraviolet Radiation. *Journal of Bacteriology*. **59 (3)**: 329 - 347
- Durbach, S., Springer, B., Machowski, E., North, R., Papavinasasundaram, K., Colston, M., Böttger, E. and Mizrahi, V.** 2003. DNA Alkylation Damage as a Sensor of Nitrosative Stress in *Mycobacterium tuberculosis*. *Infection and Immunity*. **71 (2)**: 997 - 1000
- Durbach, S., Andersen, S. and Mizrahi, V.** 1997. SOS Induction in mycobacteria: analysis of the DNA-binding activity of a Lex-A repressor and its role in DNA damage induction of the *recA* gene from *Mycobacterium smegmatis*. *Molecular Microbiology*. **26 (4)**: 643 – 653
- Ellis, E.L. and Delbrück, M.L.** 1939. The growth of bacteriophage. *Journal of General Physiology*, **22**: 365 – 384.
- Faure, D.** 1992. Improved Phenol-Based Method for the Isolation of DNA Fragments from Low Melting Temperature Agarose Gels, *BioFeedback – Biotechniques*, **13**: 25 – 26.
- Fleischmann, R.D., Alland, D., Eisen, J.A., Carpenter, L., White, O., Peterson, J., DeBoy, R., Dodson, R., Gwinn, M., Haft, D., Hickey E., Kolonay, J., Nelson, W., Umayam, L., Ermolaeva, M., Salzberg, S., Delcher, A., Utterback, T., Weidman, J., Khouri, H., Gill, J., Mikula, A., Bishai, W., Jacobs, W., Venter, J. and Fraser, C.** 2002. Whole Genome Comparison of Mycobacterium tuberculosis Clinical and Laboratory Strains. *Journal of Bacteriology*. **184 (19)**: 5479 - 5490
- Ford, M., Sarkis, G., Belanger, A., Hendrix, R. and Hatfull, G.** 1998 Genome Structure of Mycobacteriophage D29: Implications for Phage Evolution. *Journal of Molecular Biology*. **279**: 143-164
- Freeman, S., Blackett, A., Monteleone, D., Setlow, R., Sutherland, B. and Sutherland, J.** 1986. Quantitation of radiation-, chemical-, or enzyme-induced single strand breaks in non-radioactive DNA by alkaline gel electrophoresis: application to pyrimidine dimers. *Analytical Biochemistry*. **158 (1)**: 119 -129

- Friedberg, E.C., Feaver, W.J. and Gerlach, V.L.** 2000. Commentary: The many faces of DNA polymerases: Strategies for mutagenesis and for mutational avoidance. *Proceedings of the National Academy of Science, USA.* **97 (11):** 5681 – 5683
- Friedberg, E.C., Wagner, R. and Radman, N.** 2002. Specialized DNA Polymerases, Cellular Survival and the Genesis of Mutations. *Science.* **296:** 1627 - 1630
- Friedman, D.I. and Court, D.L.** 2001. Bacteriophage Lambda: Alive and Well and Still Doing its Thing. *Current Opinions in Microbiology.* **4 (2):** 201 - 207
- Friedman, N., Vardi, S., Ronen, M., Alon, U and Stavans, J.** 2005. Precise Temporal Modulation in the Response of the SOS DNA Repair Network in Individual Bacteria. *PLoS Biology.* **3 (7):** 1261 - 1268
- Gingery, R. and Echols, H.** 1967. Mutants of Bacteriophage Lambda unable to Integrate into the Host Chromosome. *Proceedings of the National Academy of Science.* **58:** 1507 - 1514
- Gordhan, B.G., Andersen, S.,J., De Meyer, A.R. and Mizrahi, V.** 1996. Construction by homologous recombination and phenotypic characterization of a DNA polymerase domain *polA* mutant of *Mycobacterium smegmatis*. *Gene.* **178(1-2):** 125 - 30
- Grange, J.M. and Redmond, W.B.** 1978. Host-Phage Relationships in the Genus *Mycobacterium* and their Clinical Significance. *Tubercle.* **59:** 203 – 225.
- Hamm-Alvarez, S., Sancar, A. and Rajagpalan, K.** 1990. The Folate Cofactor of *Escherichia coli* DNA Photolyase Acts Catalytically. *Journal of Biological Chemistry.* **265 (30):** 18656 - 18662
- Hendrix, R.W., Hatfull, G.F. and Smith, M.C.** 2003. Bacteriophages with tails: chasing their origins and evolution. *Research Microbiology.* **154:** 253 - 257
- Harris, R.S., Feng, G, Ross, K.J., Sidhu, R., Thulin, C., Longerich, S., Szigety, S.K., Winkler, M.E. and Rosenberg, S.M.** 1997. Mismatch repair protein MutL becomes limiting during stationary-phase mutation. *Genes and Development.* **11:** 2426 - 2437
- Hatfull, G.F.** Chapter 2: “Molecular Genetics of Mycobacteriophages” in *Molecular Genetics of Mycobacteria.* 2000. ASM Press, Washington D.C.
- Hatfull, G.F. and Sarkis, G.J.** 1993. DNA Sequence, structure and gene expression of mycobacteriophage L5: a phage system for mycobacterial genetics. *Molecular Microbiology.* **7:** 395 - 405
- Janion, C.** Some Aspects of the SOS response system – A critical survey. *Acta Biochimica Polonica.* **48 (3):** 599 - 610

- Karunakaran, P. and Davies, J.** 2000. Genetic Antagonism and Hypermutability in *Mycobacterium smegmatis*. *Journal of Bacteriology*. **182 (12)**: 3331 - 3335
- Kim, S-U., Maenhaut-Michel, G., Yamada, M., Yamamoto, Y., Matsui, K., Sofuni, T., Nohmi, T. and Ohmori, H.** 1997. Multiple Pathways for SOS-Induced Mutagenesis in *Escherichia coli*: An Overexpression of *dinB/dinP* results in Strongly Enhancing Mutagenesis in the Absence of any Exogenous Treatment to Damage DNA. *Proceedings of the National Academy of Science, USA*. **94**: 13792 - 13797
- Klisch, M., Sinha, R., Helbing, E. and Häder, D.** 2005. Induction of Thymine Dimers by Solar Radiation in Natural Freshwater Phytoplankton Assemblages in Patagonia, Argentina. *Aquatics Science*. **67**: 72 – 78
- Kokjohn, T.A., Schrader, J.O., Walker, J.J. and Schrader, H.S.** 1994. Effects of Stress on Bacteriophage Replication. *Biotechnology Risk Assessment: Proceedings of the Biotechnology Risk Assessment Symposium, June 1994*.
- Kondo, S. and Ichikawa, H.** 1973. Evidence that pretreatment of *Escherichia coli* cells with N-methyl-N' nitro-N-nitrosoguanidine Enhances Mutability of Subsequently Infecting Phage λ . *Molecular Genetics*. **126**: 319 - 324.
- Lee, M. and Hatfull, G.** 1993. Mycobacteriophage L5 Integrase-Mediated Site-Specific Integration In Vitro. *Journal of Bacteriology*. **175**: 6836 - 6841
- Levy, J., Fraenkel-Conrat, H. and Owens, R.** 1994. *Virology*, 3rd ed. Prentice-Hall Inc., New Jersey, USA.
- Lewis, J.A. and Hatfull, G.F.** 2003. Control of directionality in L5 integrase-mediated site-specific recombination. *Journal of Molecular Biology*. **326**: 805 – 821
- Livneh, Z.** MiniReview: DNA Damage Control by Novel DNA Polymerases: Translesion Replication and Mutagenesis. 2001. *Journal of Biological Chemistry*. **276 (28)**: 25639 – 25642.
- Madigan, M.T., Martinko, J.M. and Parker, J.** Chapter 23.3: “Mycobacterium and Tuberculosis: Pathology of tuberculosis” in *Biology of Microorganisms*, 8th Edition. 1997. Prentice Hall International, London.
- Mathews, C.K. and Van Holde, K.E.** *Biochemistry*, 2nd Edition. 1996. Benjamin Cummings Publishing Company, Inc., New York.
- McKenzie, G.J., Harris, R.S., Lee, P.L. and Rosenberg, S.M.** 2000. The SOS Response regulates adaptive mutation. *Proceedings of the National Academy of Science, USA*. **97 (12)**: 6646 – 6651.

- McKenzie, G.J. and Rosenberg, S.M.** 2001. Adaptive Mutation, Mutator DNA Polymerases and Genetic Change Strategies of Pathogens. *Current Opinions in Microbiology*. **4**: 586 - 594
- McNerney, R., Kambashi, B.S., Kinkese, J., Tembwe, R. and Godfrey-Faussett, P.** 2004. Development of a Bacteriophage Phage Replication Assay for Diagnosis of Pulmonary Tuberculosis. *Journal of Clinical Microbiology*. **42 (5)**: 2115 – 2120
- McNerney, R., Wilson, S., Sidhu, A., Harley, V., al Suwaidi, Z., Nye, P., Parish, T. and Stoker, N.** 1998. Inactivation of mycobacteriophage D29 using ferrous ammonium sulphate as a tool for the detection of viable *Mycobacterium smegmatis* and *M. tuberculosis*. *Research Microbiology* **149 (7)**: 487 – 495.
- McNerney (2004) Mycobacteriophage Replication Technology Website.**
www.lshtm.ac.uk/dfid/tb/phage.html
 Author's email address: ruth.mcnerney@lshtm.ac.uk
- Mizrahi, V. and Andersen, S.** 1998. DNA repair in *Mycobacterium tuberculosis*. What have we learnt from the genome sequence? *Molecular Microbiology*. **29**: 1331-339
- Movahedzadeh, F., Colston, M. and Davis, E.** 1997. Characterization of *Mycobacterium tuberculosis* LexA: recognition of a Cheo (*Bacillus*-type SOS) box. *Microbiology*. **143**: 929 - 936
- Negishi, K., Loakes, D. and Schaaper, R.** 2002. Saturation of DNA Mismatch-repair and Error Catastrophe by a Base Analogue in *E. coli*. *Genetics*. **161**: 1363 – 1371.
- Nesbit, C., Levin, M., Donnelly-Wu, M. and Hatfull, G.** 1995. Transcriptional regulation of repressor synthesis in mycobacteriophage L5. *Molecular Microbiology*. **16(6)**: 1045-1056
- O'Grady, P., Borden, A., Vandewiele, D., Ozgenc, A., Woodgate, R. and Lawrence, C.** 2000. Intrinsic Polymerase Activities of UmuD'2C and MucA'2B Are Responsible for Their Different Mutagenic Properties during Bypass of a T-T *cis-syn* Cyclobutane Dimer. *Journal of Bacteriology*. **182 (8)**: 2285 - 2291
- Papavinasasundaram, K.G, Anderson, C., Brooks, P., Thomas, N., Movahedzadeh, F., Jenner, P., Colston, M.J. and Davis, E.O.** 2001. Slow Induction of RecA by DNA damage in *Mycobacterium tuberculosis*. *Microbiology*. **147**: 3271 – 3279.
- Papavinasasundaram, K.G, Colston, M.J. and Davis, E.O.** 1998. Construction and Complementation of a RecA Deletion Mutant of *Mycobacterium smegmatis* reveals that the intein in *Mycobacterium tuberculosis* RecA does not affect RecA Function. *Molecular Microbiology*. **30(3)**: 525 - 535

Pedulla, M., Ford, M.E., Houtz, J.M., Karthikeyan, T., Wadsworth, C., Lewis, J.A., Jacobs-Sera, D., Falbo, J., Gross, J., Pannunzio, N.R. Brucker, W., Kumar, V., Kandasamy, J., Keenan, L, Bardarov, S., Kriakov, J., Lawrence, J.G., Jacobs, Jr., W.R., Hendrix, R.W. and Hatfull, G.F. 2003. Origin of Highly Mosaic Mycobacteriophage Genomes. *Cell*. **113**: 171 – 182.

Pedulla, M., Lee, M., Lever, D. and Hatfull, G. 1996. A novel host factor for integration of mycobacteriophage L5. *Proceedings of the National Academy of Science, USA*. **93**: 15411-15416

Marisa Pedulla:

Pittsburgh Bacteriophage Institute Website: <http://www.pit.edu/~biology/>

Author's email address: mpedulla+@pitt.edu

Peña, C.E.A., Kahlenberg, J.M. and Hatfull, G.F. 2000. Assembly and activation of site-specific recombination complexes. *Proceedings of the National Academy of Science, USA*. **97**: 7760 - 7776

Poulet, S. and Cole, S.T. 1995. Repeated DNA sequences in mycobacteria. *Archives of Microbiology*. **163**: 79 – 86

Powell, B., Court, D., Nakamura, Y., Rivas, M and Turnbough Jr, C. 1994. Rapid Confirmation of Single Copy Lambda Prophage Integration by PCR. *Nucleic Acids Research*. **22 (25)**: 5765 – 5766

Ptashne, M. A Genetic Switch. Second Edition. 1992. Cell Press and Blackwell Scientific Publications, United States of America.

Ptashne, M., Jeffery, A., Johnson, A., Maurer, R., Meyer, B., Pabo, C., Roberts, T. and Sauer, R. 1980. How the λ Repressor and Cro Work. *Cell* **19**: 1-11

Raaijmakers, H., Vix, O., Tör6, I., Golz, S., Kemper, B. and Suck, D. 1999. X-ray structure of T4 endonuclease VII: a DNA junction resolvase with a novel fold and unusual domain-swapped dimer architecture. *The EMBO Journal*. **18**: 1447 - 1458

Rachel, R., Bettstetter, M., Hedlund, B., Häring, M., Kessler, A., Stetter, K. and Prangeshvili, D. 2002. Remarkable morphological diversity of viruses and virus-like particles in hot terrestrial environments. *Archives of Virology*. **147**: 2419 - 2429

Radman, M. 1999. Enzymes of evolutionary change. *Nature: News and Views*. **401**: 866 – 869

Rado, T.A. and Bates, J.H. 1980. Mycobacteriophage Structure and Function: A Review. *Advances in Tuberculosis Research*. (Karger, Basel). **20**: 64 – 91.

- Rangarajan, S., Gudmundsson, G., Qiu, Z., Foster, P. and Goodman, M.** 1997. *Escherichia coli* DNA Polymerase II Catalyzes Chromosomal and Episomal DNA Synthesis *in vivo*. Proceedings of the National Academy of Science, USA. **94**: 946 – 951
- Roberts R.J. and Macelis, D.** 1999. RE-BLAST-restriction enzymes and methylases. Nucleic Acids Research. **27(1)**: 213-313
- Rohwer, F.** 2003. Global Phage Diversity. Cell: Previews. **113 (2)**: 141
- Rohwer, F. and Edwards, R.** 2002. The Phage Proteomic Tree: a genome based taxonomy for phage. Journal of Bacteriology. **184 (16)**: 4529 - 4535
- Sambrook, J., Fritsch, E.F. and Maniatis, T.** “Molecular Cloning – A laboratory Manual”, Second edition, 1989, Cold Spring Harbour Laboratory Press, New York.
- Sancar, G., Smith, F. and Sancar, A.** 1983. Identification and Amplification of the *E. coli phr* Gene Product. Nucleic Acids Research. **11 (19)**: 6667 - 6678
- Sander, P., Papavinasasundaram, K., Dick, T., Stavropoulos, E., Ellrott, K., Springer, B., Colston, M. and Böttger, E.** 2001. *Mycobacterium bovis* BCG recA deletion mutant shows increased susceptibility to DNA-damaging agents but wild-type survival in a mouse infection model. Infect. Immunity. **69**: 3562 - 3568
- Seawell, P., Smith, C. and Ganesan, A.** 1980. *denV* Gene of Bacteriophage T4 Determines a DNA Glycosylase Specific for Pyrimidine Dimers in DNA. Journal of Virology. **35 (3)**: 790 - 797
- Sellers, M., Nakamura, R. and Tokunaga, T.** 1970. The Effects of Ultraviolet Irradiation on Mycobacteriophages and their Infectious DNAs. Journal of General Virology. **7**: 233 - 247
- Sellers, M. and Runnals, H.** 1961. Mycobacteriophage I. Physiochemical Characterisation. Journal of Bacteriology. **81**: 442 - 447
- Sinha, R., Dautz, M. and Häder, D.-P.** 2001. A simple and efficient method for the quantitative analysis of thymine dimers in cyanobacteria, phytoplankton and macroalgae. Acta Prorozoologica. **40**: 187 - 195
- Sinha, R.P and Häder, D.-P.** 2002. UV-Induced DNA Damage and Repair: A Review. Journal of Photochemistry and Photobiology Science. **1**: 225 - 236
- Skopek, T., Liber, H., Krolewski, J. and Thilly, W.** 1978. Quantitative Forward Mutation Assay in *Salmonella typhimurium* using 8-azaguanine Resistance as a Genetic Marker. Proceedings of the National Academy of Science, USA. **75 (1)**: 410 - 414

- Smith, L.A. and Drake, J.W.** 1998. Aspects of the Ultraviolet Photobiology of Some T-Even Bacteriophages. *Genetics*. **148**: 1611 – 1618.
- Smith, B.T. and Walker G.C.** 1998. Mutagenesis and More: *umuDC* and the *Escherichia coli* SOS Response. *Genetics*. **148**: 1599 – 1610.
- Soloff, B., Rado, T., Henry, B. and Bates, J.** 1978. Biochemical and morphological characterization of mycobacteriophage R1. *Journal of Virology*. **25** (1): 253 - 262
- Spindola de Miranda, S., Kritski, A., Filliol, I., Mabilat, C., Pantiex, G. and Drouet E.** 2001. Mutations in the *rpoB* gene of the Rifampicin-resistant *Mycobacterium tuberculosis* Strains Isolated in Brazil and France. *Memorias do Instituto Oswaldo Cruz*, **96** (2): 247-250
- Stent, G.S.** Chapter 4 in: “Molecular Biology of Bacterial Viruses”. 1963. W.H. Freeman and Company, United States of America.
- Streevastian, S., Pan, X., Stockbauer, K., Connell, N., Kreiswirth, B., Whittam, T. et al.** 1997. Restricted structural gene polymorphism in the *Mycobacterium tuberculosis* complex indicates evolutionarily recent global dissemination. *Proceedings of the National Academy of Science, USA*. **94**: 9869 - 9874
- Summers, J. and Litwin, S.** 2006. Mini Review: Examining the Theory of Error Catastrophe. *Journal of Virology*. **80** (1): 20 – 26.
- Taddei, F., Radman, M., Maynard-Smith, J., Toupance, B., Gouyon, P. and Godelle, B.** 1997. Role of mutator alleles in adaptive evolution. *Nature*. **387**: 700 – 702
- Taverna, P. and Sedgwick, B.** 1996. Generation of an Endogenous DNA-Methylating Agent by Nitrosation in *Escherichia coli*. *Journal of Bacteriology*. **178** (17): 5105 - 5111
- Thomas, D., Okumoto, D., Sancar, A. and Bohr, V.** 1989. Preferential DNA repair of (6-4) photoproducts in the dihydrofolate reductase genes of Chinese hamster ovary cells. *Journal of Biological Chemistry*. **26** (30): 18005 - 18010
- Tomkins, J.D., Nelson, J.L., Hazel, J.C., Leugers, S.L., Stumpf, J.D. and Foster, P.L.** 2003. Error-Prone Polymerase, DNA Polymerase IV, Is Responsible for Transient Hypermutation during Adaptive Mutation in *Escherichia coli*. *Journal of Bacteriology*. **185** (11): 3469 - 3472
- Van Embden, J.D., Cave, M.D., Crawford, J.T., Dale, J.W., Eisenbach, K.D., Gicquel, B., Hermans, P.W., Martin, C., McAdam, R., Shinnick, T.M. et al.** 1993. Strain identification of *Mycobacterium tuberculosis* by DNA fingerprinting:

recommendations for a standardized methodology. *Journal of Clinical Microbiology*. **31 (2)**: 406 – 409

Van Embden, J.D., van Gorkon, T., Kremer, K., Jansen, R., van der Zeijst, B.A. and Schouls, L.M. 2000. Genetic Variation and Evolutionary Origin of the Direct Repeat Locus of *Mycobacterium tuberculosis* Complex Bacteria. *Journal of Bacteriology*. **182 (9)**: 2393 - 2401

Van Soolingen, D. and Hermans, P.W. 1995. Epidemiology of tuberculosis by DNA fingerprinting. *The European Respiratory Journal. Supplement*. **20**: 649 - 656

Wagner, J. and Nohmi, T. 2000. *Escherichia coli* DNA Polymerase IV Mutator Activity: Genetic Requirements and Mutational Specificity. *Journal of Bacteriology*. **182 (16)**: 4587 – 4595.

Wayne, L.G. and Hayes, L.G. 1998. Nitrate reduction as a marker for hypoxic shutdown of *Mycobacterium tuberculosis*. *Tubercle and Lung Disease*. **79 (2)**: 127 – 132.

Weber, I., Fritz, C., Ruttowski, S., Kreft, A. and Bange, F. 2000. Anaerobic nitrate reductase (*narGHJI*) activity of *Mycobacterium bovis* BCG *in vitro* and its contribution to virulence in immunodeficient mice. *Molecular Microbiology*. **35 (5)**: 1017 – 1025.

Weigle, J., J. 1953. Induction of Mutations in a Bacterial Virus. *Proceedings of the National Academy of Science, USA*. **39**: 628 - 638

White, A., Foster, F. and Lyon, L. 1962. Alteration of Colony Morphology of *Mycobacteria* Associated with Lysogeny. *Journal of Bacteriology*. **84**: 815 - 818

Wiid, I. Grundlingh, R., Bourn, W., Bradley, G., Harington, A., Hoal-van Helden, E.G., van Helden, P. 2002. O⁶-alkylguanine-DNA alkyltransferase DNA repair in *Mycobacteria*: pathogenic and non-pathogenic species differ. *Tuberculosis*. **82 (2/3)**: 45 - 53

Wood, R., D. and Hutchinson, F. 1984. Non-targeted Mutagenesis of Unirradiated Lambda Phage in *Escherichia coli* Host Cells Irradiated with Ultraviolet Light. *Journal of Molecular Biology*. **173**: 293 - 305

World Health Organization (WHO) 2003. Fact Sheet no. 101. Geneva, Switzerland: WHO.

World Health Organization (WHO) 2005. Fact Sheet no. 104. Geneva, Switzerland: WHO.

Yelser, B., Pepper, E., Goodman, M. and Finkel, S. 2002. SOS-Induced DNA Polymerases Enhance Long-term Survival and Evolutionary Fitness. Proceedings of the National Academy of Science. **99 (13):** 8737 – 8741.

APPENDIX A
Source of Chemicals and Suppliers

7H9 Middlebrook Broth	Cat No 271310	Difco
7H10 Middlebrook Agar	Cat No 262710	Difco
BioTaq™ DNA Polymerase (5u/μl)	Cat No BIO-2140	Bioline Ltd.
Oligo Synthesis	Inqaba Biotechnical Industries (Pty) Ltd	
O'RangeRuler™, 100+500bp DNA Ladder	Cat No #SM 0653	Fermentas Inc.
PCR Grade Water: Sabax Injection Water	Cat No	Adcock Ingram
Phenol, TE Equilibrated, pH	Cat No 75829	USB
Proteinase K, Recombinant, PCR Grade	Cat No 3 115 879	Roche Applied Sciences
Restriction Enzymes:		
<i>Bam</i> HI	Cat No E1010V	
<i>Kpn</i> I	Cat No E 1068Y	Amersham
<i>Xba</i> I	Cat No E 1093Y	

APPENDIX B General Media and Buffers

0.5M EDTA (pH8)

Per 100ml dH₂O:

18.61g EDTA

Add 90ml of the dH₂O and then adjust to pH8 using concentrated NaOH. Make the volume up to 100ml, filter sterilize through a 0.2µm syringe filter.

Indicator Plates

Per litre of indicator plate agar:

19g Middlebrook 7H10 agar

5ml Glycerol

900ml dH₂O

Autoclave, 10 minutes. Allow to cool then add filter sterilized glucose/NaCl stock to a final concentration of 0.2% and 0.085% respectively. Add 100ml of a fresh *M. smegmatis* mc²155 culture (OD_{600nm} 0.8), mix well.

Luria Broth and Agar

Per Litre of dH₂O:

10g Tryptone Powder

5g Yeast Extract

5g NaCl

For Agar, 10g Bacteriological Agar. Autoclave 15 - 20 minutes.

Middlebrook 7H9 Broth

Per litre of dH₂O:

4.7g Middlebrook 7H9 powder

2ml Glycerol

Autoclave, 10 minutes. Allow to cool then add filter sterilized glucose/NaCl stock to a final concentration of 0.2% and 0.085% respectively.

Middlebrook 7H10 Agar

Per litre of dH₂O:

19g Middlebrook 7H10 powder

5ml Glycerol

Autoclave, 10 minutes. Allow to cool then add filter sterilized glucose/NaCl stock to a final concentration of 0.2% and 0.085% respectively.

Phage Buffer

Prepare at least one litre, containing:

10mM Tris (pH8)

10mM MgSO₄

68mM NaCl

Adjust the pH to 7.8, then autoclave to sterilize. When cool, add CaCl₂ that has been filter sterilized through a 0.2µm filter to a final concentration of 10mM.

Soft Agar for Overlays

Prepare Luria Agar with 7g Bacteriological Agar per litre. Autoclave 15 – 20 minutes.

10 x TAE Buffer

Per litre of dH₂O:

48.4g Tris Base

11.42ml Glacial Acetic Acid

20ml 0.5M EDTA (pH8)

Make up to 1 litre. Autoclave to sterilize.

10mM TE Buffer (pH8)

Per 100ml dH₂O:

0.121g Tris-Cl

0.0372g EDTA

Add 80ml of the dH₂O and then adjust the pH to 8.0 with HCl. Make up to 100ml.

Autoclave to sterilize.

DEVELOPMENT OF MYCOBACTERIOPHAGE L5
AS A
MARKER FOR MUTATION INDUCTION IN
MYCOBACTERIA

Belinda Lea Spillings

