

ROCK MECHANICS ASPECTS OF SEQUENTIAL GRID MINING

JOHN DANIEL APPLGATE

ROCK MECHANICS ASPECTS OF SEQUENTIAL GRID MINING

John Daniel Applegate

A project report submitted to the Faculty of Engineering,
University of the Witwatersrand, Johannesburg, in partial
fulfilment of the requirements for the degree of Master of
Science in Engineering.

Johannesburg, 1991

DECLARATION

I declare that this project report is my own, unaided work. It is being submitted for the Degree of Master of Science in Engineering in the University of the Witwatersrand, Johannesburg. It has not been submitted before for any degree or examination in any other University.

~~26th~~ 26th Day of June 1991

ABSTRACT

As mining proceeds deeper on Elandsrand Gold Mine scattered mining will no longer be viable due to the excessive stress levels which would occur during mining of the final remnants between raises. Longwall mining with strike stabilizing pillars would eliminate this need for remnant mining. However, since the Ventersdorp Contact Reef on Elandsrand has a relatively large number of faults and dykes and a highly variable grade, longwall mining would result in an excessive amount of off-reef mining and mining of unpayable reef.

Sequential grid mining, a new mining method utilizing dip stabilizing pillars as well as bracket pillars for most faults and dykes, has been proposed as an alternative. The purpose of this investigation is to determine the suitability of this mining method for meeting the rock mechanics requirements for deep mining, and to compare it with the previously proposed scattered mini-longwall mining method.

The computer modelling shows that long-term pillar stability may be a problem, but that there is little difference between dip pillars and strike pillars in this regard. Classified tailings backfill significantly improves pillar stability and will therefore be vital for deep mining unless the extraction ratio is decreased. Results indicate that the haulages are sited at an adequate depth below the dip stabilizing pillars. Modelling of energy release rates indicates that sequential grid mining has higher peak values than scattered mini-longwall mining. However, the maximum energy release rates can be kept to acceptable levels for Elandsrand if proper mining sequences are followed. Properly placed backfill also reduces peak values to acceptable levels.

Sequential grid mining improves the control of faults and dykes. This is the biggest rock mechanics advantage of sequential grid mining. Initial development enables the geological structure to

be delineated well in advance of stoping operations. This allows bracket pillars for most faults and dykes to be properly designed and implemented (the dip pillars are usually shifted to the geological discontinuity). The bracket pillars virtually eliminate the dangerous practice of mining through faults and dykes. Properly designed bracket pillars will also greatly reduce seismicity associated with slip along faults and dykes.

Sequential grid mining will therefore enable the mining of Elandsrand's deep, highly faulted reef to be done more profitably and more safely. Profitability will be improved mainly because mining can be done more selectively and with less off-reef stoping and development. Safety will be improved because the faults and dykes will be controlled better at acceptable stress levels and with acceptable stability of pillars and haulages.

ACKNOWLEDGEMENTS

The author wishes to thank the management of Elandsrand Gold Mining Company Limited for their support during the writing of this report.

Special thanks are due to all of the members of the Elandsrand Rock Mechanics Department, but especially to Mr A W Lagerweij for his assistance with the computer modelling. Thanks also to Dr T O Hagan of the AAC West Rand Regional Office for his valuable advice.

<u>CONTENTS</u>		Page
	<u>DECLARATION</u>	i
	<u>ABSTRACT</u>	ii
	<u>ACKNOWLEDGEMENTS</u>	iv
	<u>CONTENTS</u>	v
	<u>LIST OF FIGURES</u>	vii
1	<u>INTRODUCTION</u>	1
2	<u>DESCRIPTION OF SEQUENTIAL GRID MINING</u>	4
2.1	Geology of Elandsrand Gold Mine	4
2.2	Layout and Mining Sequence	6
2.3	Design Process	10
2.4	Production Advantages	11
3	<u>IMPROVED CONTROL OF FAULTS AND DYKES WITH SEQUENTIAL GRID MINING</u>	14
3.1	Bracket Pillars	14
3.2	Approach to Faults and Dykes	15
4	<u>COMPUTER MODELLING TO INVESTIGATE THE SUITABILITY OF SEQUENTIAL GRID MINING</u>	17
4.1	Stability of Dip Pillars Versus Strike Pillars	22
4.1.1	Predicted Average Pillar Stresses	23
4.1.2	Results From Modelling of the Hoek and Brown Failure Criterion	27
4.2	Siting of Footwall Development Beneath Dip Pillars	34
4.3	Comparison of the Energy Release Rates for Sequential Grid Mining Versus Scattered Mini-longwall Mining	36
4.4	Summary of Computer Modelling Results	40

	Page
5 <u>COMPARISON OF SEQUENTIAL GRID MINING TO SCATTERED MINI-LONGWALL MINING</u>	43
5.1 Production Aspects	43
5.2 Rock Mechanics Aspects	45
6 <u>RECOMMENDATIONS FOR FUTURE WORK</u>	48
7 <u>SUMMARY AND CONCLUSIONS</u>	51
7.1 Summary of Results	51
7.2 Conclusions	53
<u>APPENDIX A</u> <u>INPUT VARIABLES FOR COMPUTER MODELLING</u>	55
<u>REFERENCES</u>	56

LIST OF FIGURES

Figure	Page
2.1 Location of Elandsrand Gold Mine	5
2.2 Elandsrand Sequential Grid Mining Layout	7
2.3 Stopping Sequence for Sequential Grid Mining	8
2.4 Bracket Pillar Example	9
3.1 Correct Approach to Geological Features With Sequential Grid Mining	16
4.1 Windows for Detailed Face Modelling	20
4.2 Windows for Worst Case Pillar Stability	21
4.3 Average Pillar Stresses for Sequential Mining with an Underhand Configuration	24
4.4 Average Pillar Stresses for Sequential Grid Mining with an Overhand Configuration	25
4.5 Average Pillar Stresses for Scattered Mini-longwall Mining	26
4.6 Failure Zones for Strike Pillar Without Backfill	28
4.7 Failure Zones for Strike Pillar With Backfill	29
4.8 Failure Zones for Dip Pillar Without Backfill	31
4.9 Failure Zones for Dip Pillar With Backfill and an Underhand Configuration	32
4.10 Failure Zones for Dip Pillar With Backfill and an Overhand Configuration	33
4.11 Off-Reef Stresses Below Dip Pillar	35
4.12 Energy Release Rates for Sequential Grid Mining With an Underhand Configuration	37
4.13 Energy Release Rates for Sequential Grid Mining With an Overhand Configuration	38
4.14 Energy Release Rates for Scattered Mini-longwall Mining	39
5.1 Elandsrand Scattered Mini-longwall Layout	44

1 INTRODUCTION

Sequential grid mining, a new mining method, has been proposed for mining the deeper areas of Elandsrand Gold Mine. Scattered mining is being practiced in the shallower areas of the mine using crosscuts and raises spaced 150 to 180 metres apart. The final stages of this mining method are hazardous due to the highly stressed remnants which are formed. Using scattered mining in the deeper areas of the mine will result in unacceptable stress levels and energy release rates.

Longwall mining is normally considered to be the best strategy⁽¹⁾ for deep mining. This is due to the following rock mechanics requirements.

- Stresses and energy release rates must be kept to acceptable levels.
- The formation of remnants must be avoided.
- Stabilizing pillars and/or backfill must be used for regional support.
- Follow-behind haulages must be used to avoid the high stresses below the advancing stoping faces.

Conventional longwall mining would not be feasible for Elandsrand due to problems with adverse geological structure, erratic grades and high production requirements. The presence of a relatively large amount of faulting would result in a high proportion of off-reef mining. Longwall mining also does not allow for selective mining of low grade or unpayable areas. The combined effect would be to lower the overall recovered grade of the mine to a level which would be unacceptable in the current economic environment. Production would also be insufficient due to the limited amount of face available from one set of longwalls.

Scattered mini-longwall mining has been considered as an alternative to conventional longwall mining. Mining with scattered mini-longwalls would be more viable since it would increase face length. However, there would still be problems with faults and dykes and the variable grades.

Sequential grid mining has been proposed to overcome these deficiencies. At present this method is being implemented for mining the shallower portion of Elandsrand's subshaft reef. This report investigates the ability of sequential grid mining to meet the rock mechanics requirements for mining the deeper portion of Elandsrand's subshaft reef (down to 98 level - 2 800 metres below surface). Comparisons have also been made with scattered mini-longwall mining.

The following section describes the geological setting of Elandsrand Gold Mine and gives details of sequential grid mining as planned for this environment. The advantages from a production perspective are presented, but not in detail as this was the subject of a previous investigation.

The improved control of faults and dykes which results from sequential grid mining is discussed in Section 3. This is one of the major advantages of this new mining method.

Computer modelling was done to assess the suitability of sequential grid mining for meeting the rock mechanics requirements for deep mining. Comparisons were made with scattered mini-longwall mining where applicable. The modelling is described and the results are presented in Section 4.

Section 5 describes scattered mini-longwall mining and compares it with sequential grid mining.

Section 6 gives recommendations for future work which may be necessary to improve the design and implementation of sequential grid mining in other areas.

The final section briefly summarizes the most important results of this investigation and contains the conclusions regarding this new mining method.

2.1 Geology of Elandsrand Gold Mine

Elandsrand Gold Mine is located near Carletonville in the Far West Rand mining area (Figure 2.1). At present the only reef mined is the Ventersdorp Contact Reef. This is a conglomerate reef band with a strike of north 65 degrees east and a dip of approximately 24 degrees to the south. Grade is highly variable⁽²⁾ with unpay zones typically occupying sand-filled channels. The reef is characterised by a relatively large amount of faulting with throws of less than ten metres. A large proportion of the mine's seismicity is associated with these faults and dykes.

The hangingwall is Ventersdorp Lava which is strong but variable in nature. The uniaxial compressive strength (UCS) is approximately 300 megapascals (MPa). Flow bedding planes, joints and altered lavas (including pillow lavas) are some of the problems experienced in various areas of the mine. The mine has experienced problems⁽³⁾ with rockbursts at relatively low energy release rates (ERR's), possibly due to these local variations in the lava. Other contributing factors are a relatively large amount of flat faulting which extends into the hangingwall⁽⁴⁾ and the brittle nature of lava. All of these factors lead to poor hangingwall which is susceptible to damage by seismicity.

The footwall is a competent quartzite (UCS 250 MPa and higher, from tests) which extends to a depth of approximately 430 metres below reef on the eastern boundary and about 550 metres below reef on the western boundary. This is important because haulages can be carried deep in the footwall with no problems with shales or other incompetent rock strata.

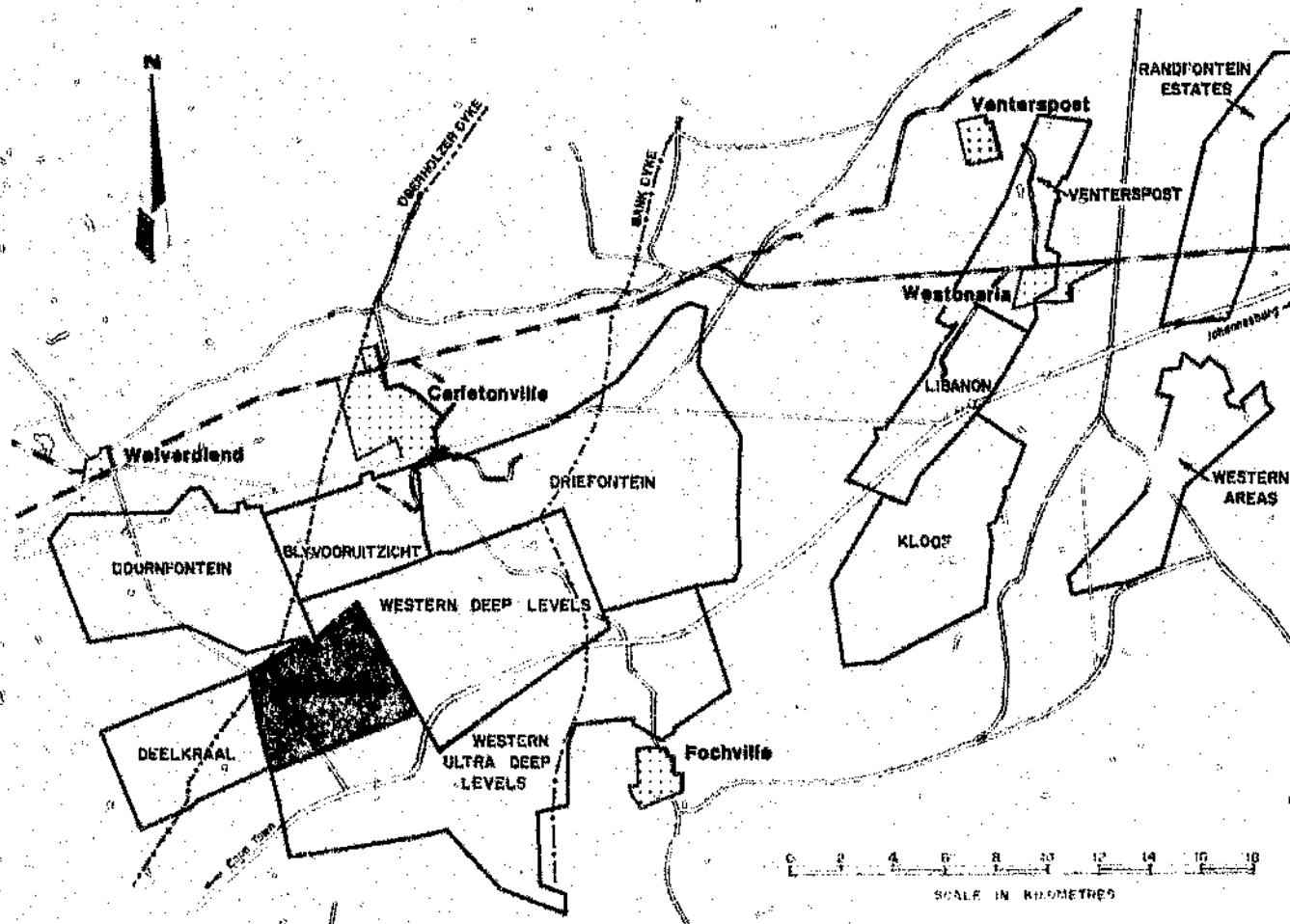

FIGURE 2.1. LOCATION OF BLANDSRAND GOLD MINE

2.2 Layout and Mining Sequence

Sequential grid mining combines the scattered mining concept with a system of partial extraction. The partial extraction (85 %) reduces the overall stress levels while also eliminating holing of panels into mined out areas. Haulages and return airways are excavated ahead of stoping operations at a depth of 80 metres vertically below reef. Crosscuts and raises are developed from the haulages at 200 metre intervals. The raises are then ledged and equipped before stoping commences. Dip stabilizing pillars (30 metres wide) are left between raise lines (see proposed layout in Figure 2.2).

The sequence of mining is important, hence the name "sequential". "Grid" refers to the grid of regularly spaced crosscuts and raises. The overall direction of mining is from the shaft pillar outwards, moving from raise line to raise line out toward the boundaries. The mining from each raise proceeds first towards the shaft pillar to approach the final pillar configuration at a low span (see detail of layout in Figure 2.3). Then mining proceeds away from the shaft pillar to the stopping line for the next pillar.

The spacing between raises is limited by the maximum effective scraping distance. When a fault or dyke is present the dip pillar would be shifted to form a bracket pillar on the geological feature (Figure 2.4). This pillar would not necessarily be positioned centrally between the raises so the maximum scraping distance would increase for many panels. It is therefore important to keep the raise spacing small to allow for this flexibility with regard to the position of the pillar. However, there are also advantages which would result from increasing the raise spacing (less development, larger pillars). The 200 metre raise spacing was chosen as a reasonable compromise.

2.2 Layout and Mining Sequence

Sequential grid mining combines the scattered mining concept with a system of partial extraction. The partial extraction (85 %) reduces the overall stress levels while also eliminating holing of panels into mined out areas. Haulages and return airways are excavated ahead of stoping operations at a depth of 80 metres vertically below reef. Crosscuts and raises are developed from the haulages at 200 metre intervals. The raises are then ledged and equipped before stoping commences. Dip stabilizing pillars (30 metres wide) are left between raise lines (see proposed layout in Figure 2.2).

The sequence of mining is important, hence the name "sequential". "Grid" refers to the grid of regularly spaced crosscuts and raises. The overall direction of mining is from the shaft pillar outwards, moving from raise line to raise line out toward the boundaries. The mining from each raise proceeds first towards the shaft pillar to approach the final pillar configuration at a low span (see detail of layout in Figure 2.3). Then mining proceeds away from the shaft pillar to the stopping line for the next pillar.

The spacing between raises is limited by the maximum effective scraping distance. When a fault or dyke is present the dip pillar would be shifted to form a bracket pillar on the geological feature (Figure 2.4). This pillar would not necessarily be positioned centrally between the raises so the maximum scraping distance would increase for many panels. It is therefore important to keep the raise spacing small to allow for this flexibility with regard to the position of the pillar. However, there are also advantages which would result from increasing the raise spacing (less development, larger pillars). The 200 metre raise spacing was chosen as a reasonable compromise.

ELANDSRAND GOLD MINING COMPANY LIMITED

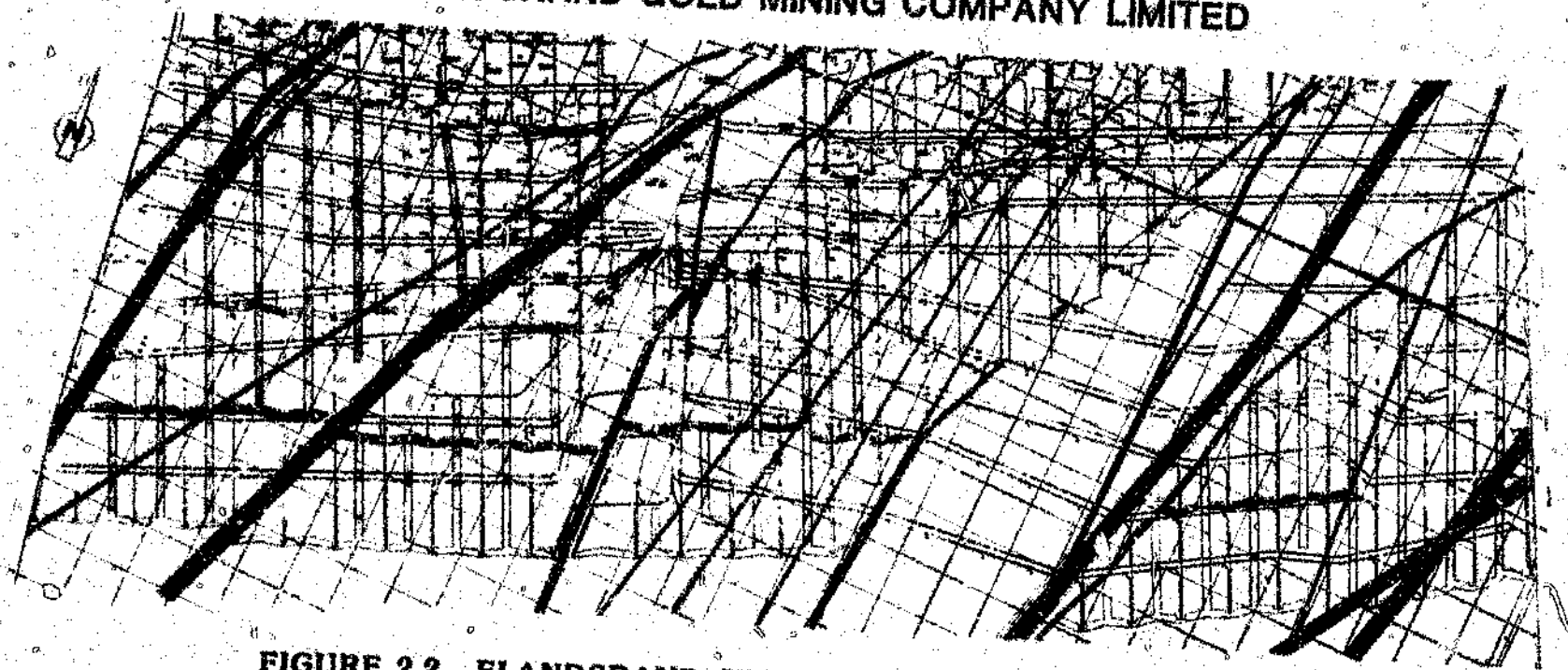

FIGURE 2.2. ELANDSRAND SEQUENTIAL GRID MINING LAYOUT

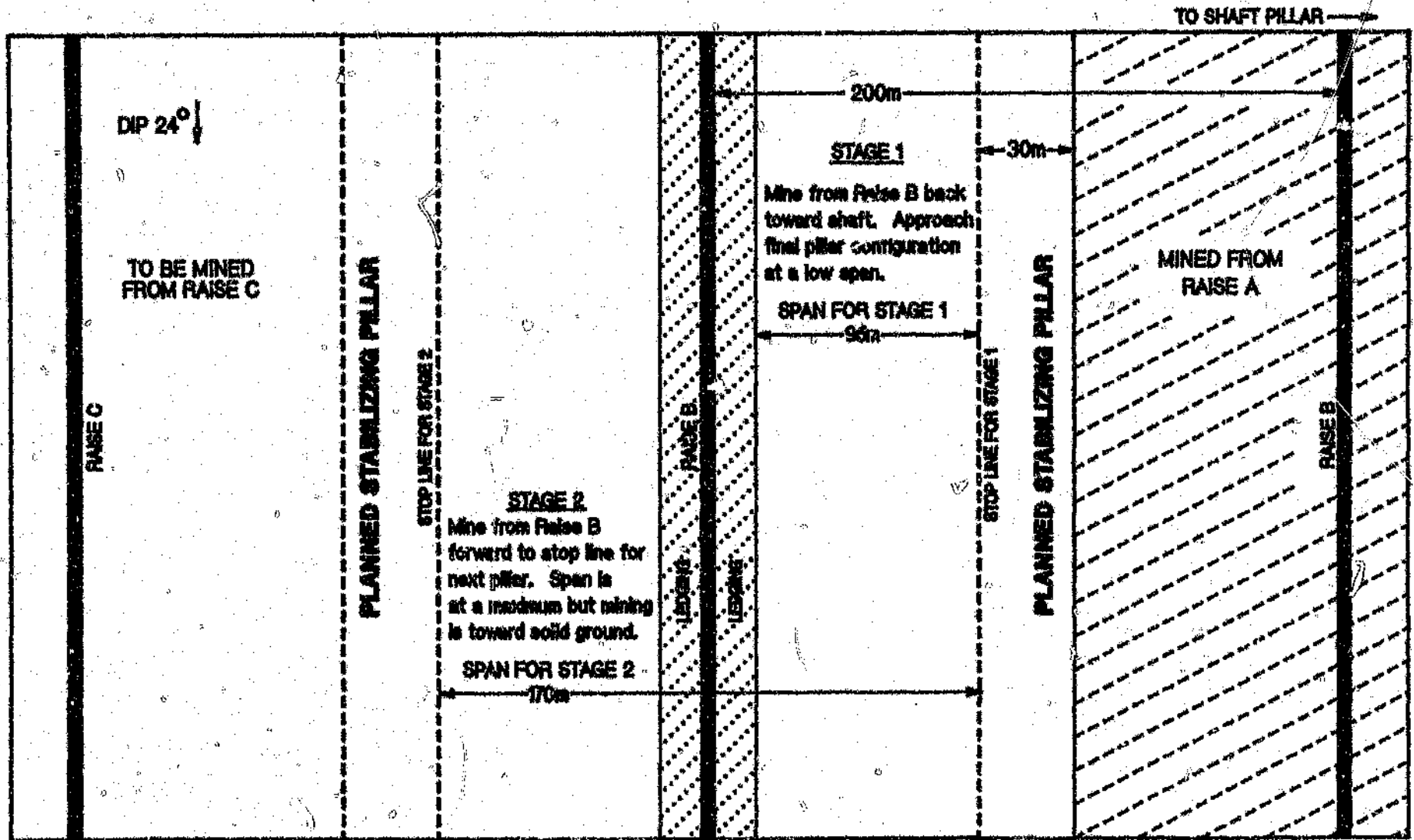

FIGURE 2.3 STOPING SEQUENCE FOR SEQUENTIAL GRID MINING

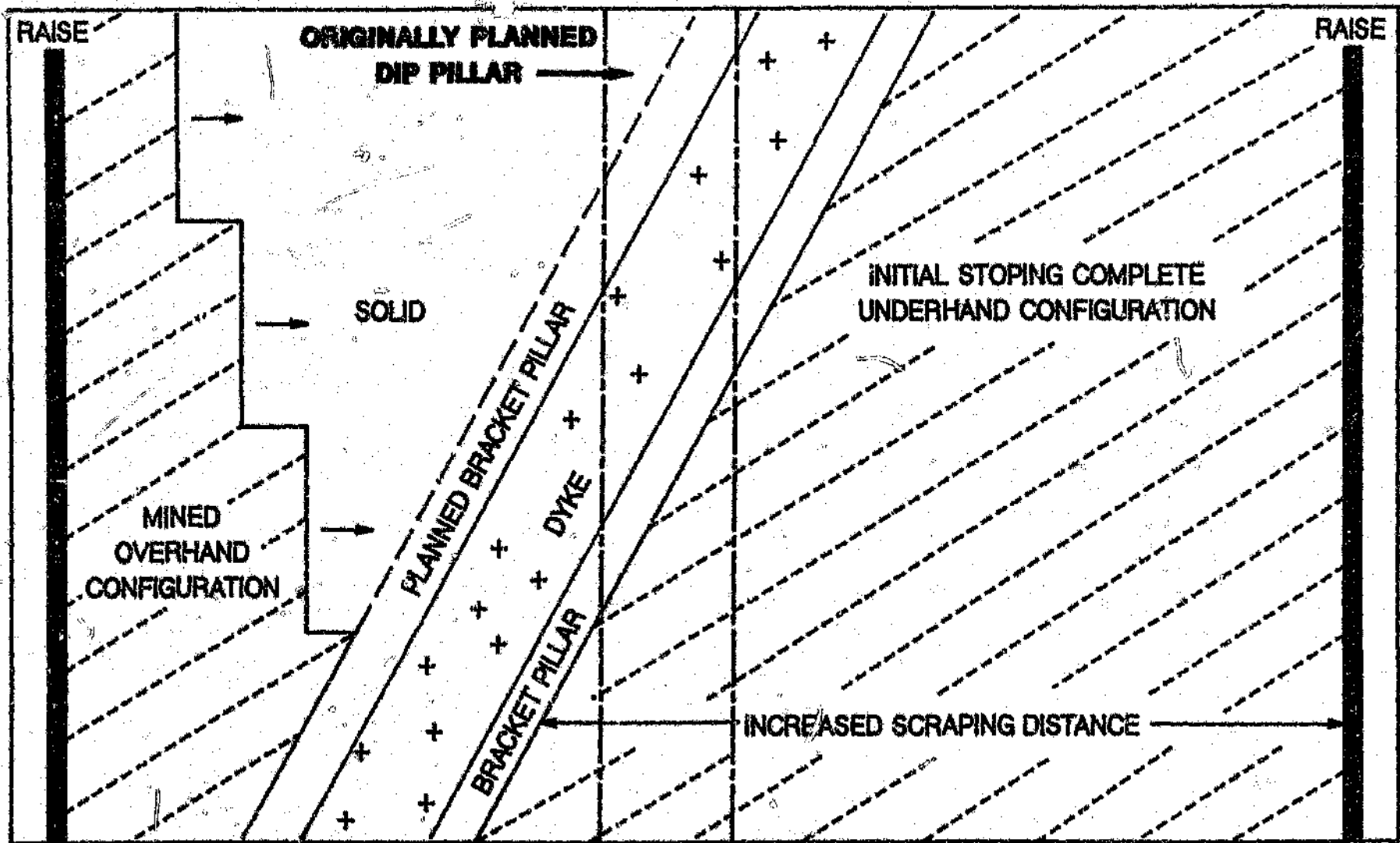

FIGURE 2.4 BRACKET PILLAR EXAMPLE

2.3 Design Process

The following is the design process which leads to the detailed short-term mining plan for a specific area of the mine. The emphasis is placed less on maximizing the areal extraction rate and more on maximizing the gold extracted profitably from each area of the mine.

- **Preliminary Design :** The preliminary design incorporates dip stabilizing pillars at the standard width and spacing. Bracket pillars on major geological discontinuities are included, with the dip pillars adjusted accordingly. Designs are based on practical considerations and rough "rules of thumb" only. Computer modelling would be pointless at this stage due to the inaccuracy of the geological information. This design is sufficient for long-term planning of two years or more. The important aspects are extraction rates and development layouts so that development can be planned suitably.

- **Final Design :** Once the geological information concerning structure and grade has been confirmed (by drilling operations plus mapping and sampling of the raises) the process of determining a final design commences. It is important that personnel from rock mechanics, geology, ventilation, survey and especially production are involved in this design process. Unpay areas are first identified since mining in these areas should only be done if required for overtopping of footwall development or if it can be justified to reach a payable area of reef. Then bracket pillars along faults and dykes are planned as necessary. Finally, dip stabilizing pillars are placed between raises where no unpay or bracket pillars are planned. Where possible these pillars are shifted to low grade areas. Agreement is then reached on the mining sequence to be used between the pillars.

This mining sequence and pillar layout are then checked via rock mechanics computer modelling. Any major adjustments to the design are again discussed with the relevant personnel from other departments.

The decision on whether or not to use backfill in particular areas should be more strongly influenced by economic factors. For example, in low grade areas it may be more profitable to leave large pillars so that the areas in between can be mined at low stress levels. If stress levels are low mining should be possible with lower support costs (e.g. no backfill or hydraulic props instead of packs) and higher productivity due to the improved conditions. In high grade areas an investment in more expensive backfill might yield an attractive return if pillar requirements are reduced. If backfill must be used in an area due to poor ground conditions then the cut-off grade for determining unpay areas must be increased proportionately.

- **Changes to Designs :** Any significant changes to mining sequences or pillar layouts are checked again via computer modelling. These changes must be minimized due to the lengthy procedure involved. Unauthorized changes, especially mining beyond pillar limits, must be strongly discouraged. This is extremely important as disciplined mining is necessary to achieve the aims of improving profitability while ensuring safe working conditions. When changes are necessary the procedure for arriving at a final design is repeated.

2.4 Production Advantages

An investigation⁽⁵⁾ into the production aspects of sequential grid mining has already been completed for Elandsrand Gold Mine. The following advantages summarize the most important results of this investigation.

- **Less Off-reef Development** : Sequential grid mining greatly reduces off-reef development requirements by eliminating follow-behind development and reducing the number of boxholes. The actual planning layout for the deepest portion of Elandsrand's subshaft reef indicates that there will be 28,7 stoping square metres for every metre of off-reef development. This ratio includes all off-reef development outside of the shaft pillar. The ratio for scattered mini-longwall mining of the same area would be only 16,9 square metres per metre while the typical ratio for conventional mini-longwall mining is 20 to 24 square metres per metre.

- **Improved Selectivity and Flexibility** : Sequential grid mining allows more selectivity and flexibility with regard to planning and mining. Grade trends can be accurately determined in advance, therefore planning can be adjusted to ensure that the mine remains profitable (e.g. mine more high grade areas if necessary, leave unpay areas as pillars). In one particular area of the mine the pillars were changed from straight dip pillars to larger, slightly diagonal pillars incorporating unpay areas. The revised plan(6) resulted in an increase in the in-situ grade of the area planned to be mined of over two grams per ton. It also resulted in lower stress levels and significantly lower production costs.

Backfill can be implemented selectively based on stress levels, expected seismicity, regional support requirements, or actual underground conditions. If the effectiveness of backfill for regional support is proven (and if it is economically justifiable) the dip pillars could readily be reduced in size or replaced by backfill (more likely cemented backfill).

- **Less Off-reef Stopping** : Sequential grid mining minimizes off-reef stopping since most faults and dykes are left intact with bracket pillars. The need to do waste mining to overstop

shallow footwall development is also virtually eliminated.

- **More Face Length** : Sequential grid mining allows a greater length of face to be mined simultaneously. Spare face length can also be kept available to deal with unexpected problems such as drops in grade, fires and major rockburst damage.

3 IMPROVED CONTROL OF FAULTS AND DYKES WITH SEQUENTIAL GRID MINING

One of the most dangerous aspects of deep level gold mining is mining through or near major geological discontinuities. This mining can induce large magnitude seismic events associated with shear slip along the plane of the fault or dyke. Sequential grid mining greatly improves safety by virtually eliminating the need to mine through faults and dykes and by enabling the mining in the vicinity of the geological discontinuity to be done in the correct configuration. The clamping effect of properly designed bracket pillars will reduce the seismicity associated with shear slip along faults and dykes and contribute significantly toward improved safety.

3.1 Bracket Pillars

Sequential grid mining allows most faults and dykes to be left intact with bracket pillars (strips of unmined reef left on either side of the discontinuity). This is accomplished by shifting the dip stabilizing pillars to incorporate faults and dykes. On Elandsrand this change is usually relatively easy to implement since the strike of most faults and dykes runs close to the dip direction of the reef (the dip of the Ventersdorp Contact Reef on Elandsrand is roughly north to south while the predominant trend of faults and dykes is north-northeast to south-southwest). The design of these bracket pillars is feasible since the position and orientation of geological discontinuities is well defined during initial development, long before stoping commences. Implementation of the bracket pillars is relatively easy since the fault or dyke can be approached from both sides. Another major advantage of leaving bracket pillars is that it minimizes the need for the extremely dangerous operation of mining through or near a fault or dyke.

3.2 Approach to Faults and Dykes

The need to avoid mining numerous panels onto or through a fault or dyke at the same time⁽¹⁾ is now an accepted basic principle of deep-level gold mining in South Africa. The problem is a sudden large increase in ESS along the plane of weakness as the panels approach simultaneously. Mining one panel at a time up to the discontinuity results in small increases in ESS and should therefore lead to smaller, less dangerous seismic events. Sequential grid mining allows this to be accomplished without adversely affecting production. The advance development determines the orientation of the geological discontinuity before stoping commences. The desired mining configuration (overhand or underhand) is determined, then implemented by adjusting the order in which the panels are started from each raise. For example, east mining from a raise could be done in an overhand configuration to favourably approach a fault trending from northeast to southwest. West mining from the same raise could be done in an underhand configuration to approach a fault with a similar orientation in the correct manner (Figure 3.1). The mining configuration would normally be overhand to avoid the inherent problems associated with having an unmined area below the bottom gully (i.e. the gully has to be mined with a heading or with a portion of ledging on the downdip side). The configuration can be changed to underhand when it is necessary due to the presence of a fault or dyke with an adverse orientation or when mining below a mined out area.

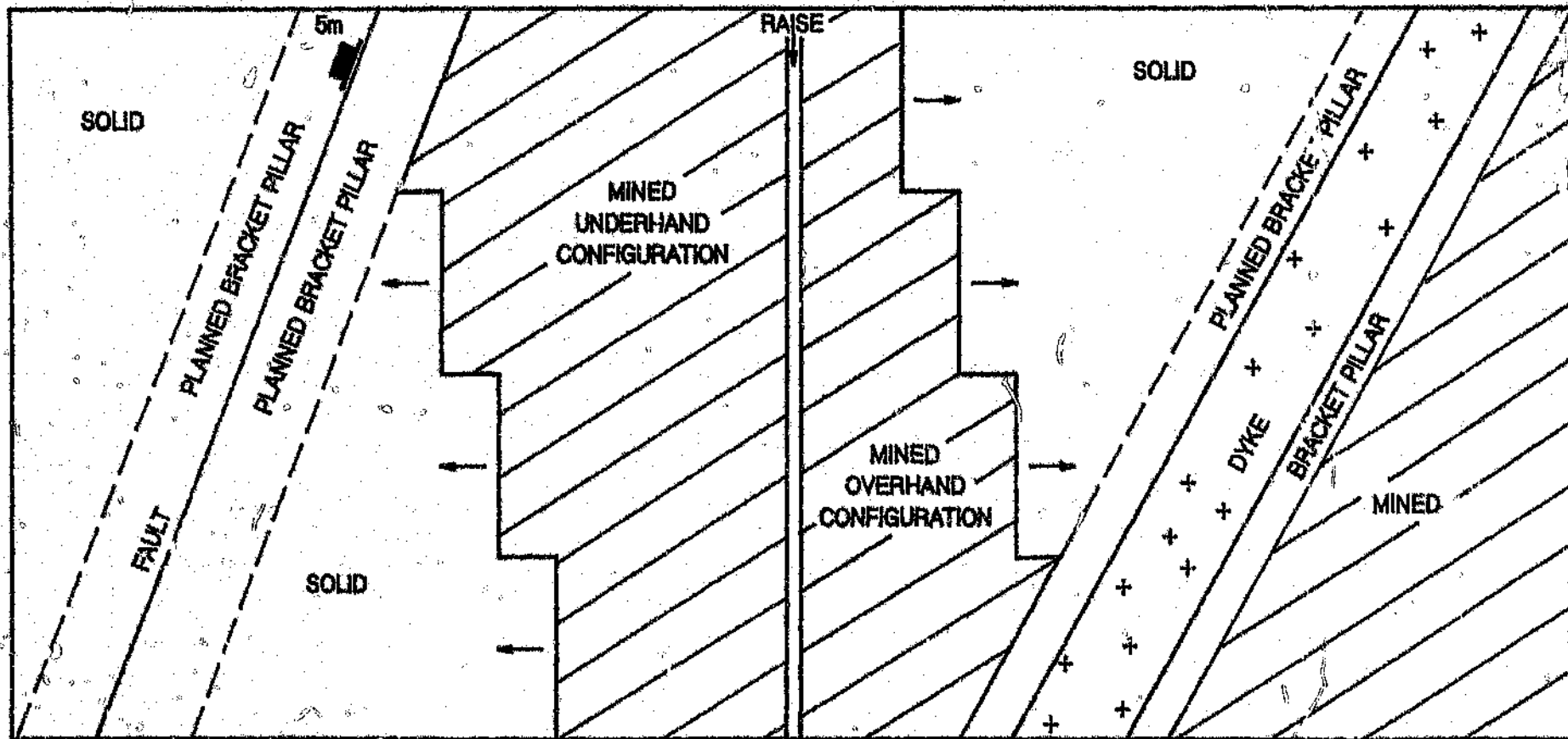

FIGURE 3.1 CORRECT APPROACH TO GEOLOGICAL FEATURES WITH SEQUENTIAL GRID MINING

4 COMPUTER MODELLING TO INVESTIGATE THE SUITABILITY OF SEQUENTIAL GRID MINING

Computer modelling using Minsim-D (Phase III) was done to assess several rock mechanics aspects of sequential grid mining. Comparisons were made with scattered mini-longwall mining where applicable.

The objectives of stabilizing pillars and controlled mining sequences are to reduce face stresses (and therefore energy release rates) and to effectively clamp geological discontinuities. Reduced face stresses result in less seismicity and stress fracturing and therefore better mining conditions and improved safety. Proper clamping of faults and dykes should significantly reduce the amount of seismicity resulting from shear-slip along these features. These objectives will not be realized unless the pillars themselves are properly designed and therefore stable. Experience to date has been mainly with strike stabilizing pillars and longwall mining. This experience does, however, help with the design of dip stabilizing pillars.

Average pillar stresses and the Hoek and Brown failure criterion were modelled to investigate the stability of the 30 metre wide dip pillars and the 35 metre wide strike pillars. Different pillar sizes were used because the actual layouts were compared and the extraction ratio was kept constant at 85 %. The extraction ratio of 85 %⁽⁷⁾ has been used for pillar designs on Western Deep Level and Elandsrand Gold Mines and was based on average pillar stress and energy release rate reduction considerations. The results of these pillar designs have generally been favourable, but this extraction ratio will probably have to decrease for ultra-deep mining unless backfill proves successful.

The siting of the haulages for sequential grid mining was checked by modelling off-reef maximum principal stresses. The energy release rates (ERR's) for sequential grid mining and

scattered mini-longwall mining were modelled for comparative purposes.

Excess shear stress (ESS) was not modelled as part of this investigation. The ESS criterion is used to attempt to quantify the potential for a seismic event with a shear-slip mechanism. This type of seismic event can occur in solid, previously unfractured ground. However, the ESS criterion is normally only used to assess the potential for slip along a pre-existing major geological discontinuity. Minor geological discontinuities are also assessed if they have a history of seismic activity, which is often the case at Elandsrand. Each geological discontinuity is unique in terms of its strike, dip, thickness, throw and position relative to mining operations. It would be extremely difficult to do computer modelling on a representative range of possible configurations. This has therefore not been attempted.

All modelling was done with ten metre leads between panels. The following variations were modelled.

- Sequential grid mining using an overhand configuration, first without backfill and then with classified tailings backfill. Several steps were modelled since the stress levels change as the final pillar configurations are approached.
- As above but with an underhand configuration.
- Scattered mini-longwall mining using an overhand configuration, first without backfill and then with classified tailings backfill.
- As above but with an underhand configuration.
- Worst case modelling of sequential grid mining and scattered mini-longwall mining with mining of the entire coarse window complete except for pillars, first without backfill and then

- 13 -

with classified tailings backfill.

Computer modelling was done with a five metre fine window block size. A full list of input variables is given in Appendix A. The configurations modelled were kept simple and conceptual. The detailed face modelling was done for stoping between 95 level (2 700 metres below surface) and 98 level (2 800 metres below surface). The entire coarse window above 95 level was modelled as mined out except for the relevant pillar configuration, as was the area east of the current stoping (Figure 4.1). Worst case pillar stability was modelled with the pillar at 98 level elevation in the centre of the coarse window with the entire coarse window mined out except for the relevant pillar configuration (Figure 4.2).

The backfill modelling was done using single step modelling with fill width equal to the stoping width. Step by step modelling would give a more accurate assessment of fill performance, but this level of accuracy is not required for the purposes of this report. Using fill width equal to the stoping width slightly over-estimates the benefit of backfill. However, this assumption is justified by two factors. First, shrinkage (resulting in a gap between the backfill and the hangingwall) has only been noted in rare instances on Elandsrand Gold Mine due to the relatively steep dip (24 degrees), the good backfill material quality and good placement techniques. Second, convergence prior to filling will be minimal near the raise for sequential grid mining. This backfill will ultimately have higher stress regeneration than the backfill placed near the pillars, therefore it will contribute most of the regional support benefit. This is not the case for scattered mini-longwalls, but the same assumption regarding backfill placement height was made in order to be consistent. Therefore the benefit of backfill will be overestimated more for the strike pillars than for the dip pillars.

SEQUENTIAL GRID MINING

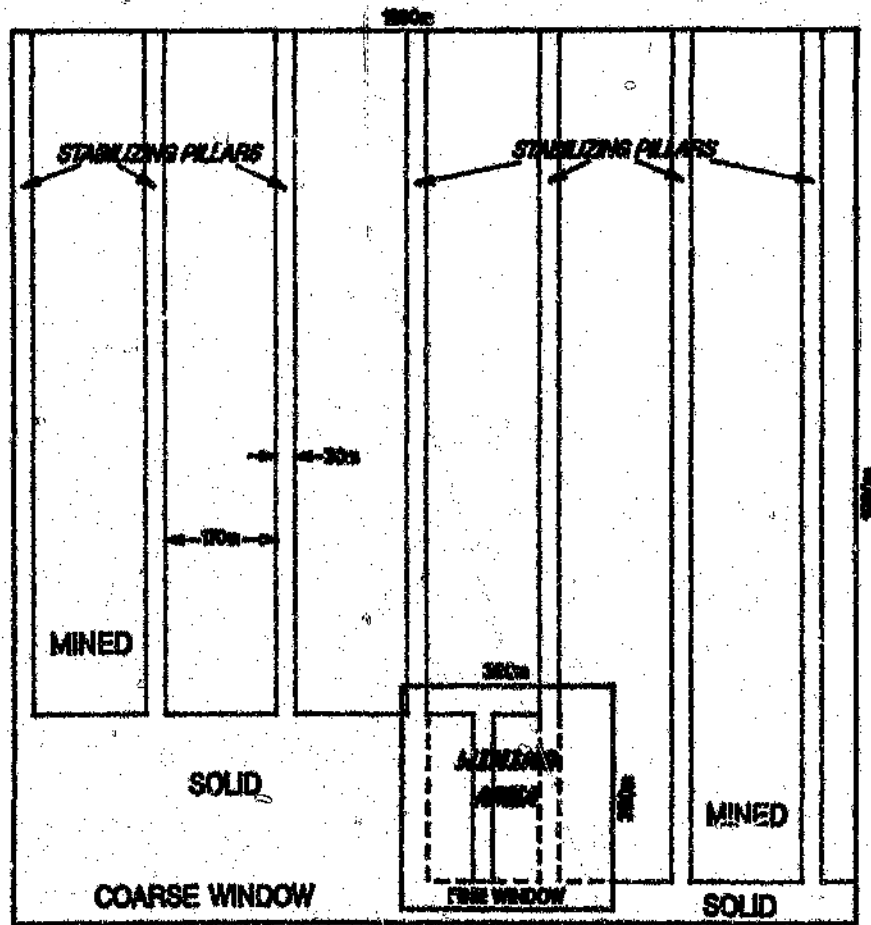

SCATTERED MINI-LONGWALL MINING

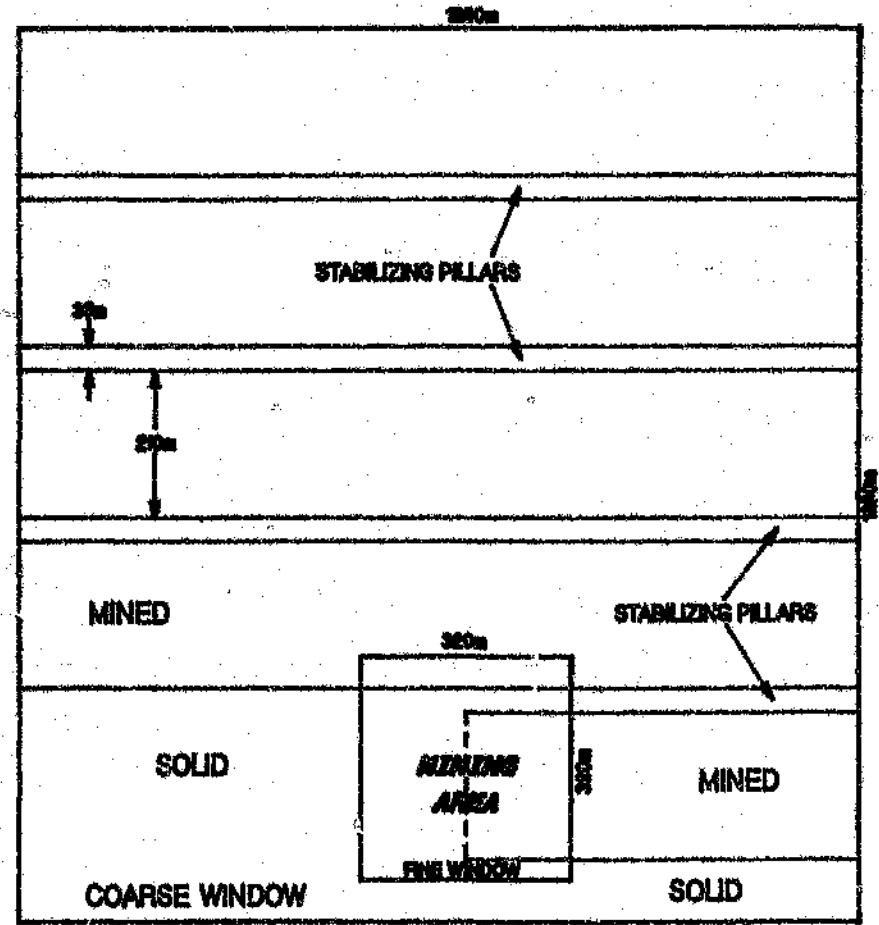
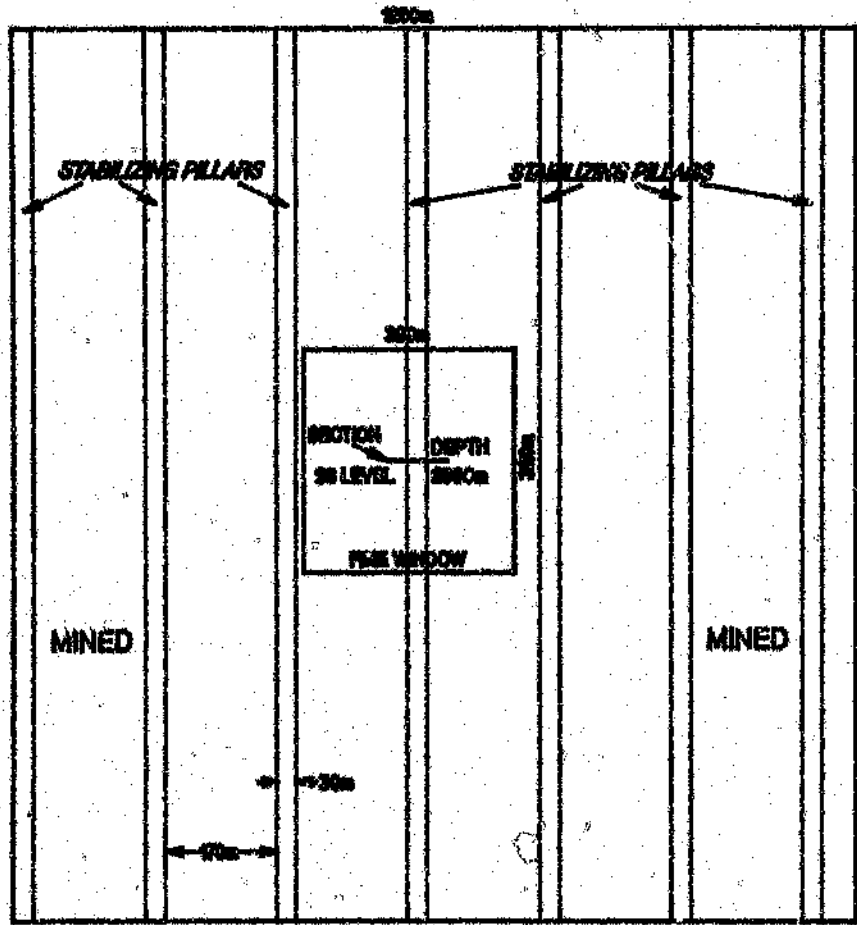

FIGURE 4.1 WINDOWS FOR DETAILED FACE MODELLING

SEQUENTIAL GRID MINING



COARSE WINDOW

SCATTERED MINI-LONGWALL MINING

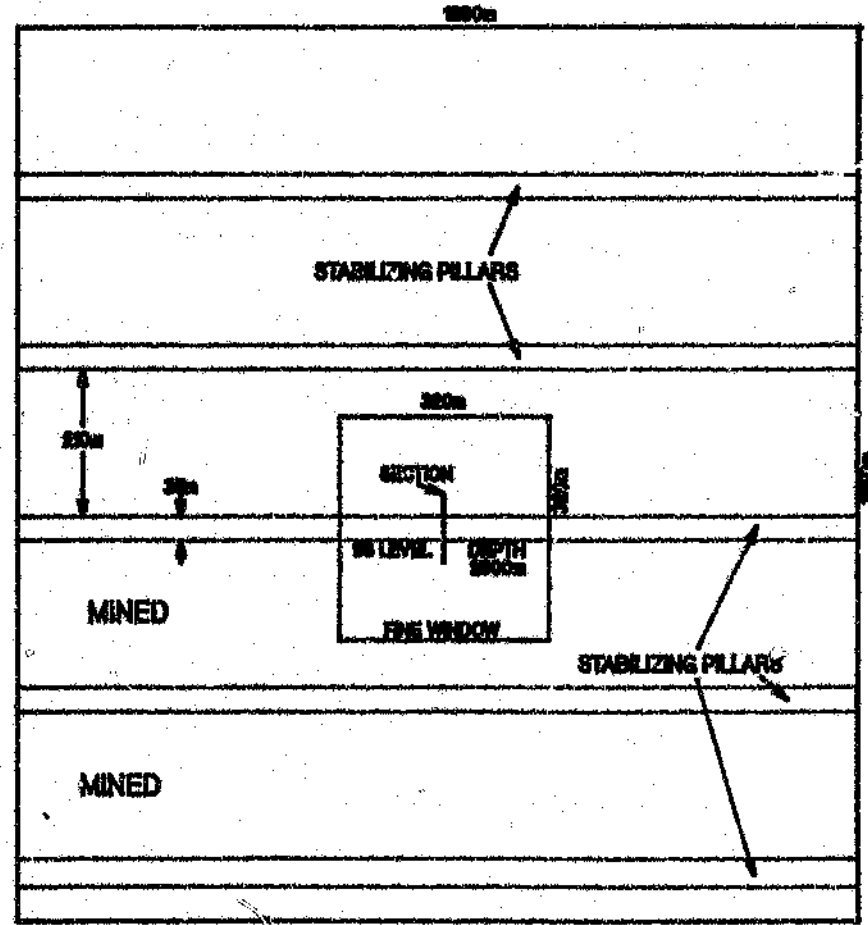

COARSE WINDOW

FIGURE 4.2 WINDOWS FOR WORST CASE PILLAR STABILITY

The backfill was modelled as being placed ten metres behind each active face and up to the edge of each pillar. This is being accomplished with dip pillars on Elandsrand, but would be difficult with strike pillars.

The backfill characteristics used were an 'a' value of 11,12 MPa (this is the stress generated at a closure of 50 % of the ultimate compressive strain of the fill material) and a 'b' value of 0,40 (this is the ultimate compressive strain of the fill material). A hyperbolic stress-strain curve was assumed. The results of the computer modelling investigation are summarized in Section 4.4.

4.1 Stability of Dip Pillars Versus Strike Pillars

Pillars which are parallel to the dip of the reef⁽⁹⁾ should be more stable than strike pillars, provided all other factors are equal. This is due to dip pillars being oriented in the same direction as the major ride component resulting from the downdip shear stress along the plane of the reef. This shear stress can be calculated by resolving the major principal stress, which is vertical, into normal and shear stress components. The computer modelling of the Hoek and Brown failure criterion does not show any significant difference between the dip and strike pillars, probably because the dip pillars modelled were 30 metres wide while the strike pillars were 35 metres in width. Another problem with strike stabilizing pillars⁽¹⁰⁾ which has been encountered in practice at Western Deep Levels Gold Mine is the adverse effect of faults or dykes intersecting the pillars. These intersections have been a focal point for seismic activity. The dip pillars will, for the most part, avoid this problem since they will be shifted to the discontinuity and designed to clamp it in a stable manner.

The two criteria modelled to investigate pillar stability were the average pillar stress and the Hoek and Brown failure criterion. The stability of bracket pillars for clamping faults and dykes has not been addressed as each pillar will be unique. The design of bracket pillars will be difficult but will utilize the above criteria plus the excess shear stress criterion.

4.1.1 Predicted Average Pillar Stresses

For a systematic pillar configuration without backfill the average pillar stress is a function of the virgin stress (normal to reef) and the extraction ratio only. There would therefore be no difference between dip and strike stabilizing pillars at the same depth and extraction ratio. However, since dip stabilizing pillars are oriented in the direction of the overall ride and are loaded more evenly than strike pillars they should be stable at a higher average pillar stress.

The maximum design level⁽¹¹⁾ for average pillar stress is 2,5 times the UCS of the host rock. Since quartzite (UCS on Elandsrand of 250 MPa) is the weakest host rock the maximum acceptable average pillar stress for Elandsrand Gold Mine is 625 MPa. At an extraction ratio of 85 %, dip of 24 degrees and k-ratio of 0,5 this would only be reached at a depth of approximately 250 metres. At 98 level elevation (2 800 metres below surface) and Elandsrand's reef characteristics the theoretical maximum average pillar stress is 454 MPa, well within the maximum design level.

Computer modelling indicated that the maximum average pillar stress that can be expected while stoping is in progress in the vicinity of the pillar is between 325 and 383 MPa for sequential grid mining (Figures 4.3 and 4.4) and between 396 and 404 MPa for scattered mini-longwalls (Figure 4.5). Worst case modelling with the entire coarse window mined out with systematic pillars increased the average pillar stress to 458 MPa for sequential grid mining and 496 MPa for scattered mini-longwalls. Backfill

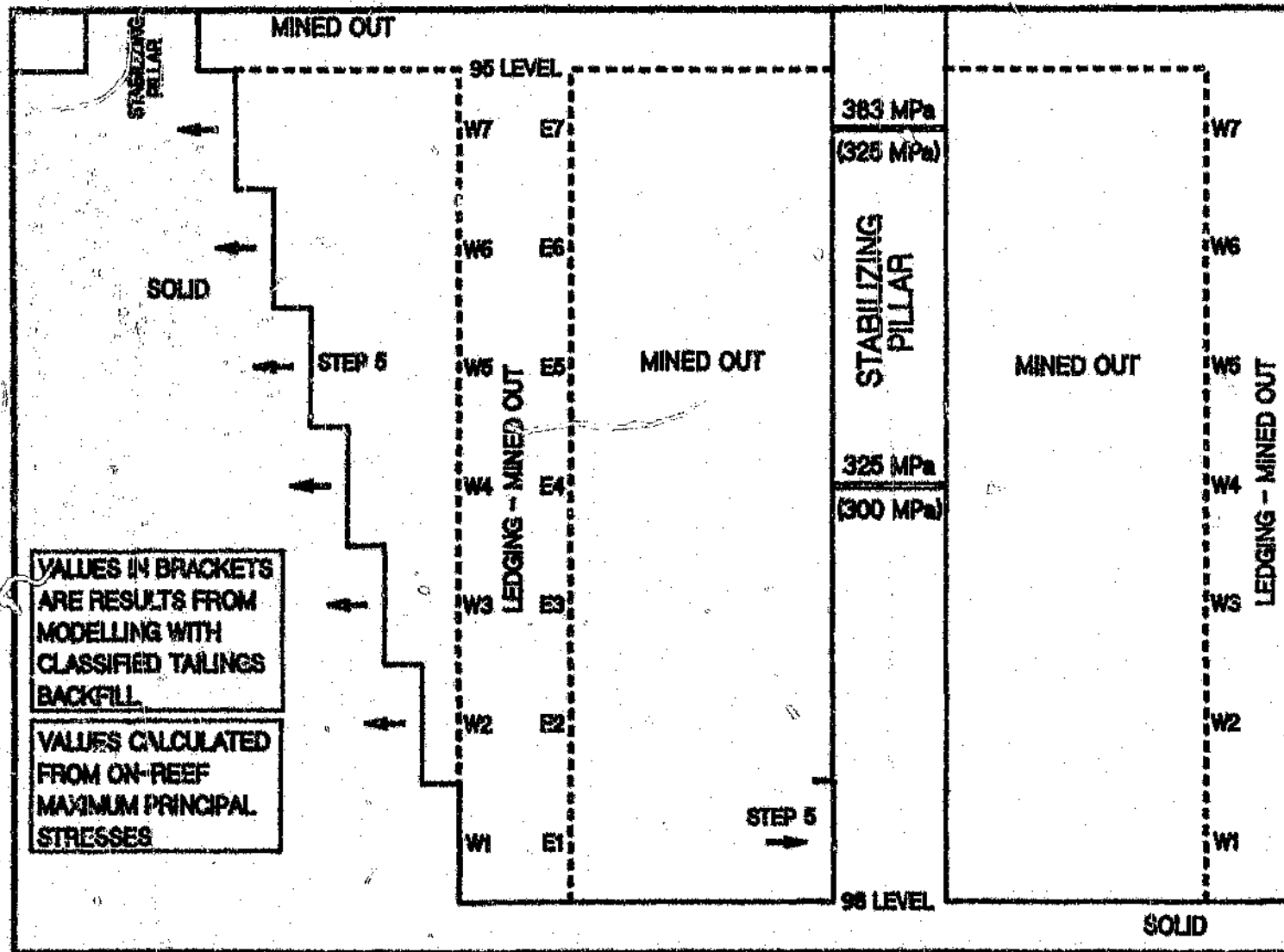

FIGURE 4.3 AVERAGE PILLAR STRESSES FOR SEQUENTIAL GRID MINING WITH AN UNDERHAND CONFIGURATION

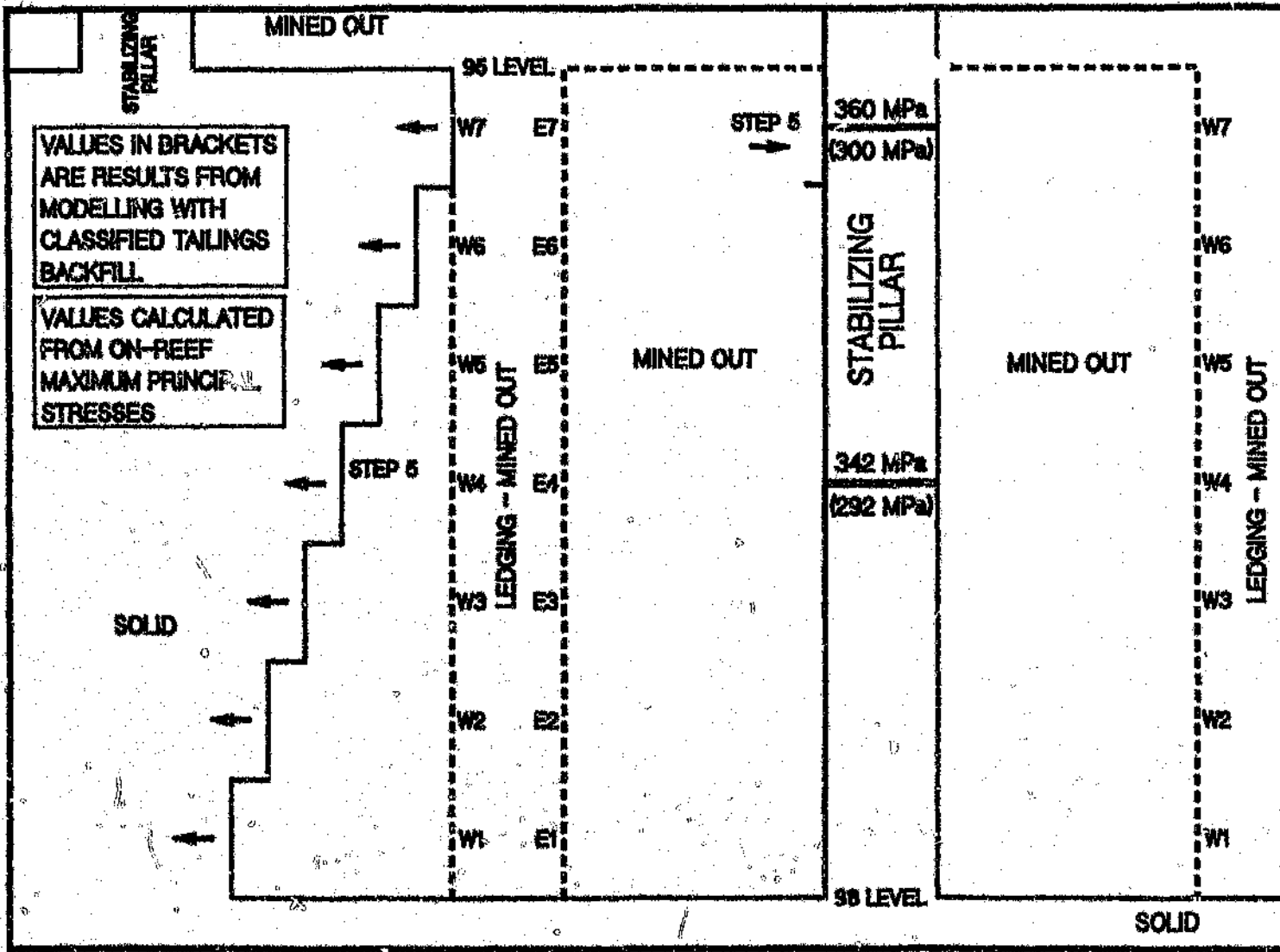

FIGURE 4.4 AVERAGE PILLAR STRESSES FOR SEQUENTIAL GRID MINING WITH AN OVERHAND CONFIGURATION

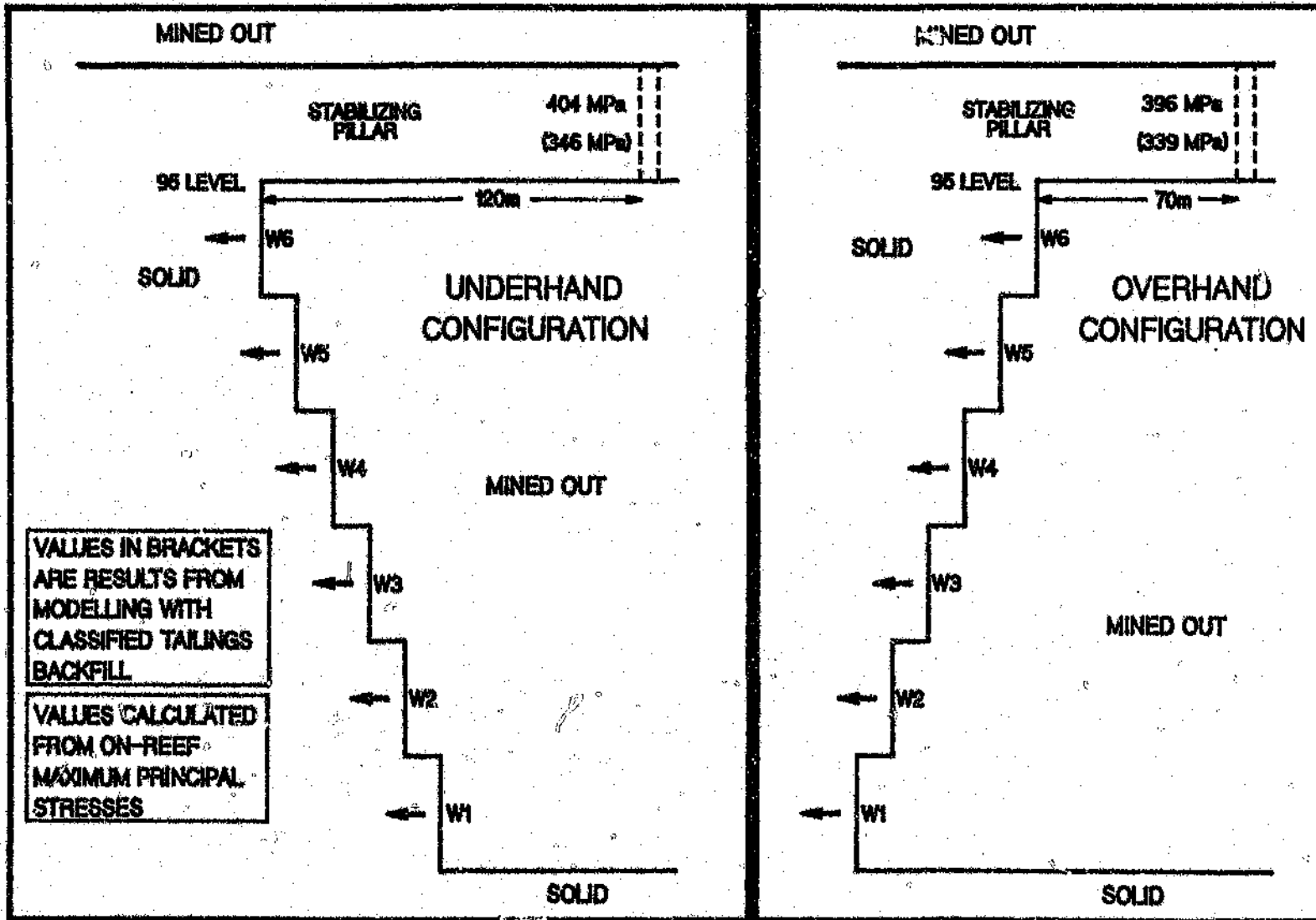

FIGURE 4.5 AVERAGE PILLAR STRESSES FOR SCATTERED MINI-LONGWALL MINING

reduced these values by 7,5 to 20 %. All of these average pillar stress levels would be acceptable even if the more conservative estimate of the UCS of the footwall quartzite of 200 MPa was used.

4.1.2 Results from Modelling of the Hoek and Brown Failure Criterion

The modelling of the Hoek and Brown failure criterion was done with the benchmark variable 'HBVG'. This assumes a very good quality rockmass⁽¹²⁾ with an 'm' value of 7,5, an 's' value of 0,1 and a UCS of 200 MPa. The results indicate zones where failure, either tensile or compressive, would be expected due to the stress conditions calculated. For this report the interpretation⁽¹³⁾ is that a large failed zone in the footwall on either side of the pillar indicates that shear-slip is likely to occur along the pillar edge. If the failed zones beneath the pillar edges connect in the footwall then a wedge-type failure of the pillar foundation⁽¹⁴⁾ due to the pillar punching downwards is likely to occur. This is not theoretically correct since it is using elastic modelling to predict inelastic failure modes. However, it should be acceptable for the rough comparative purposes of this paper.

Results for the strike stabilizing pillar between 95 and 98 levels indicate that the foundation will be completely failed within 120 metres of the face if backfill is not used (Figure 4.6). Similar results were obtained for this pillar at 70 metres from the face with an overhand configuration. The results of the modelling with classified tailings backfill indicate a significant improvement, though there is still a large failed zone in the footwall on the downdip side of the pillar (Figure 4.7). Worst case modelling (entire coarse window mined out except for pillars) of the pillar between 98 and 100 levels yielded similar results for the modelling with backfill.

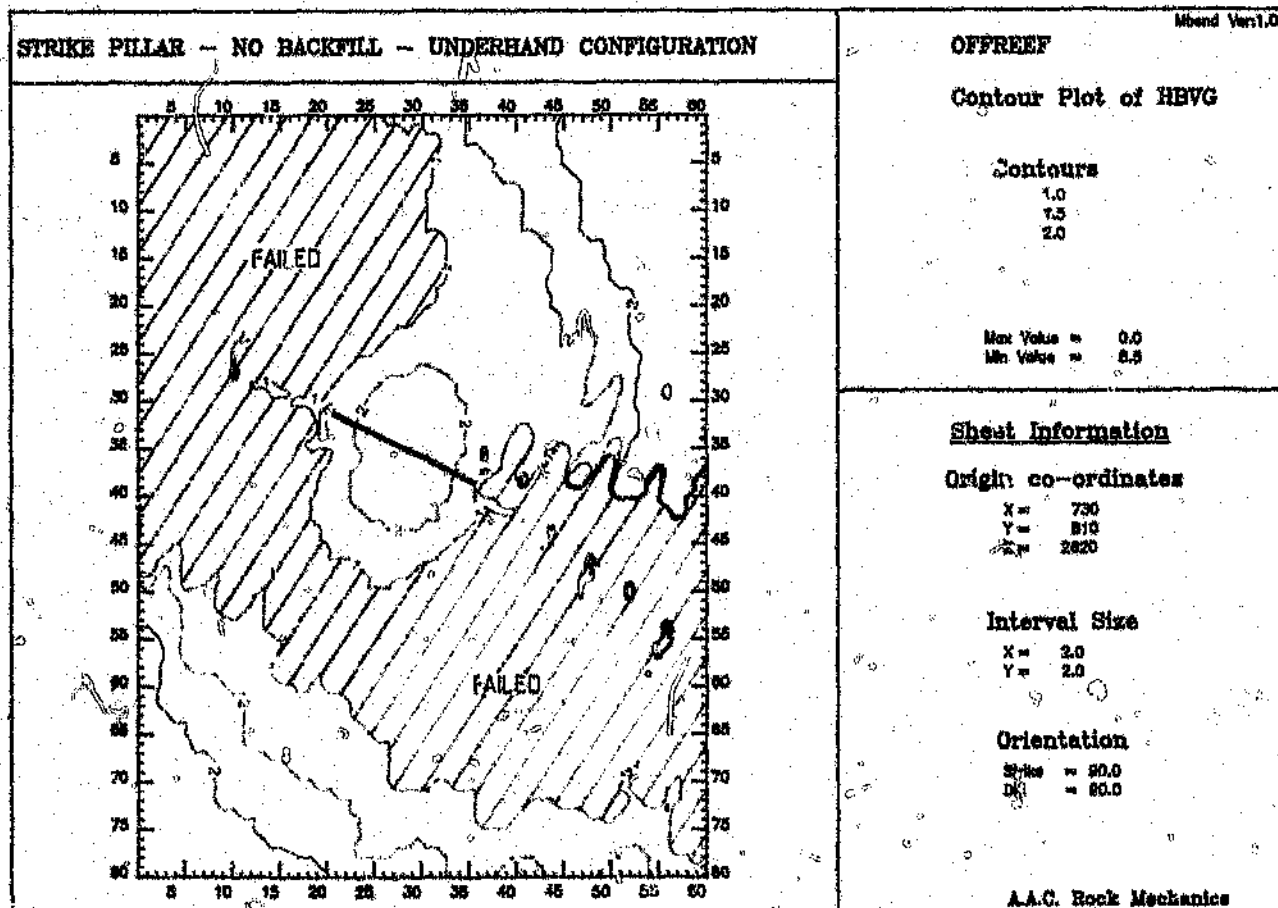

FIGURE 4.6. FAILURE ZONES FOR STRIKE PILLAR WITHOUT BACKFILL

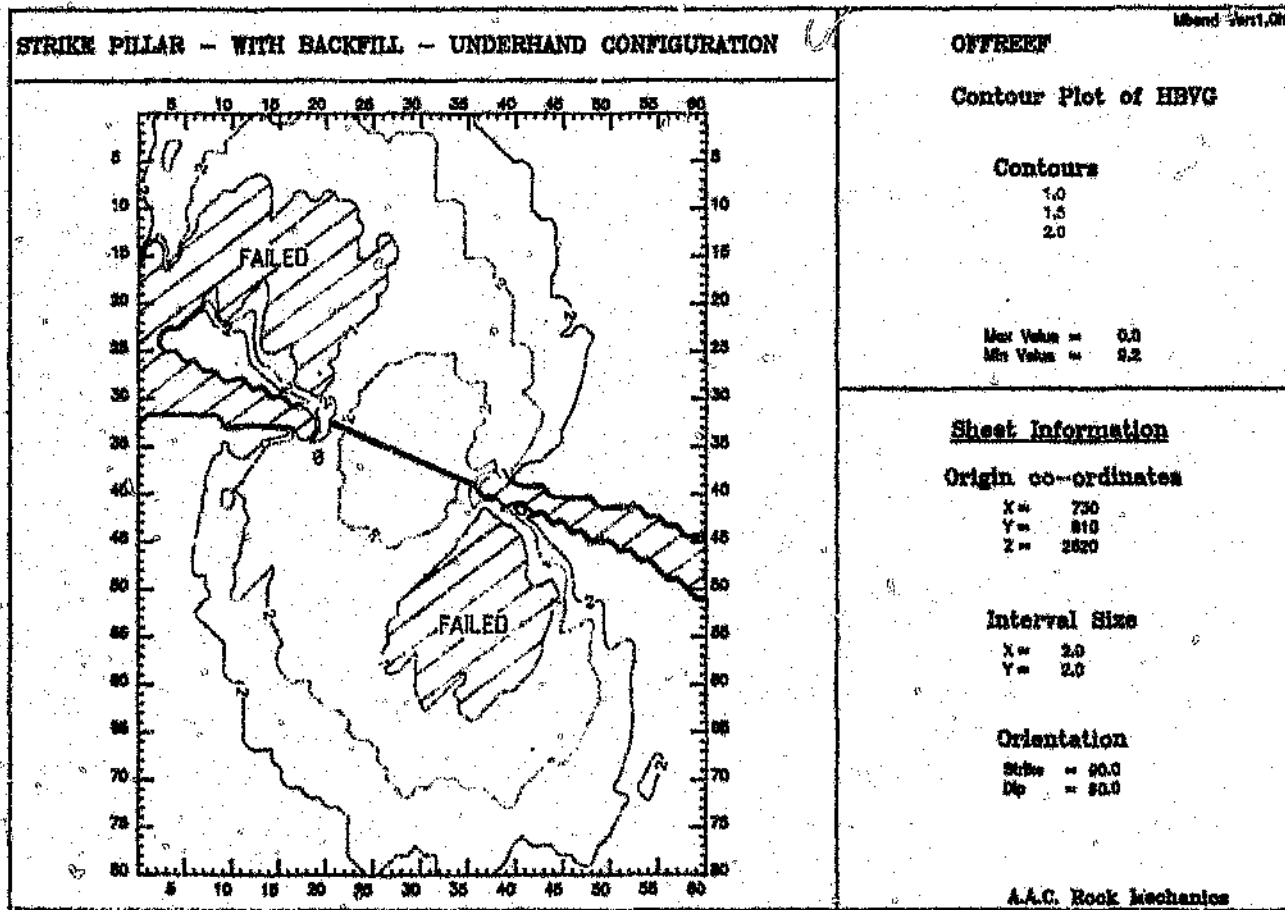

FIGURE 4.7. FAILURE ZONES FOR STRIKE PILLAR WITH BACKFILL

Therefore the 35 metre strike pillars can be expected to fail via a pillar punching mechanism relatively close to the face if backfill is not used. Backfill reduces the potential failure to shear-slip along a single plane below the downdip side of the pillar, even in the long-term worst case. This is due to the asymmetry of the failed area below the pillar. Mining in an overhand configuration below a mined out area results in the potential foundation failure problems occurring closer to the stope face, thereby increasing the risk that seismicity associated with pillar foundation failure could adversely affect stoping operations.

The modelling for the 30 metre wide dip stabilizing pillars was first done with an underhand mining configuration. The last mining up to the final pillar configuration would therefore be done by the bottom panel. The section for the failure criterion was taken through the pillar approximately 100 metres above this bottom panel (the location of the section is shown in Figure 4.3). This would be the highest stressed portion of the pillar close enough to affect the bottom panel. Results of the modelling without backfill indicate that the foundation of the pillar would be completely failed in this area (Figure 4.8). The addition of backfill reduces the failed zones to relatively small, even lobes on either side of the pillar (Figure 4.9). This indicates that pillar foundation failure will not affect stoping operations if backfill and an underhand face configuration are utilized.

The results of the modelling with an overhand configuration below the mined out area indicate that foundation failure will occur while stoping is in progress even if backfill is utilized (Figure 4.10). The last mining up to the final pillar configuration would be done by the top panel, therefore the section was taken at this position (the location of the section is shown in Figure 4.4). If there was no mined out area above the top panel the results would have been similar to those for the underhand configuration. This illustrates the importance of the

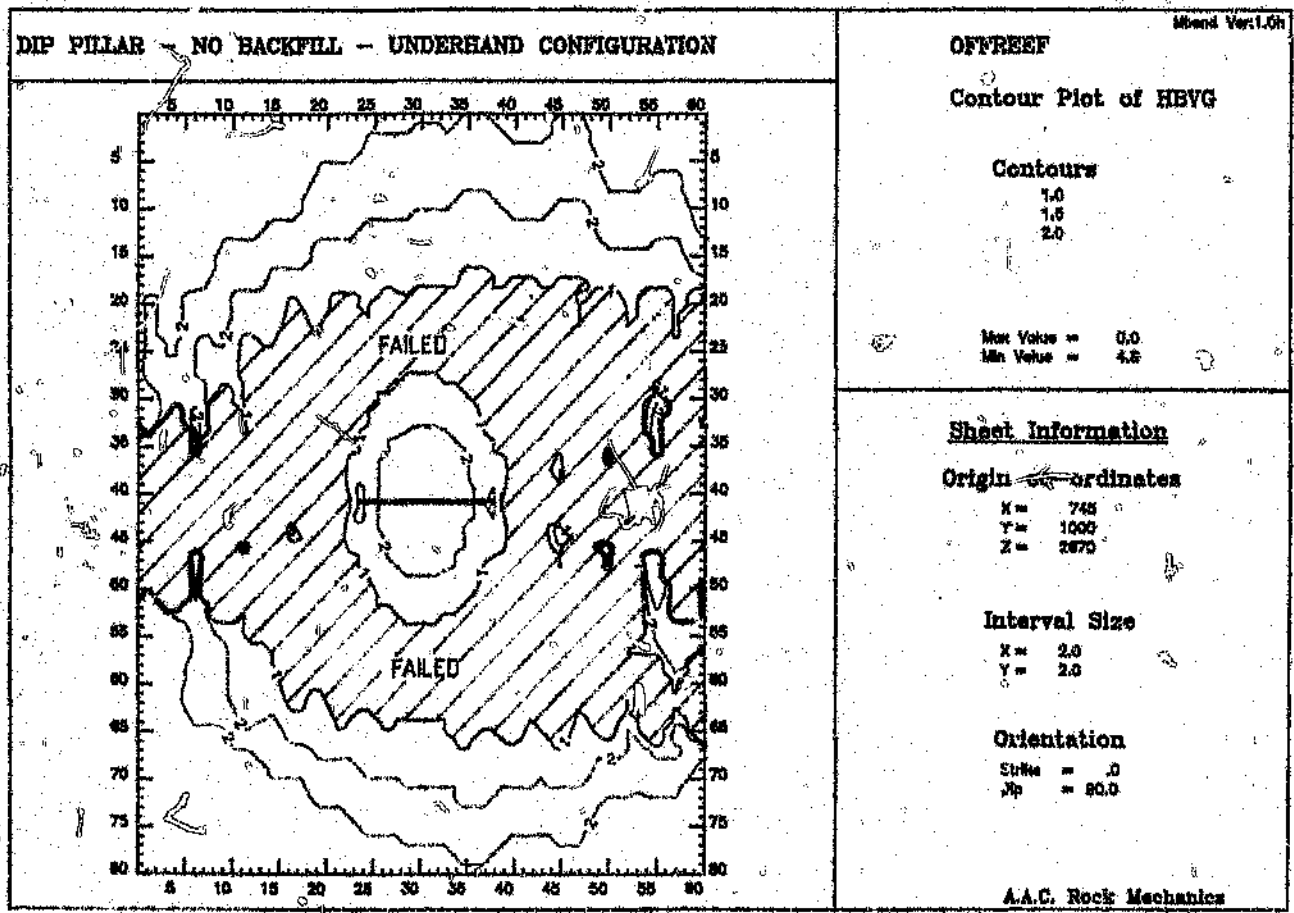

FIGURE 4.8. FAILURE ZONES FOR DIP PILLAR WITHOUT BACKFILL

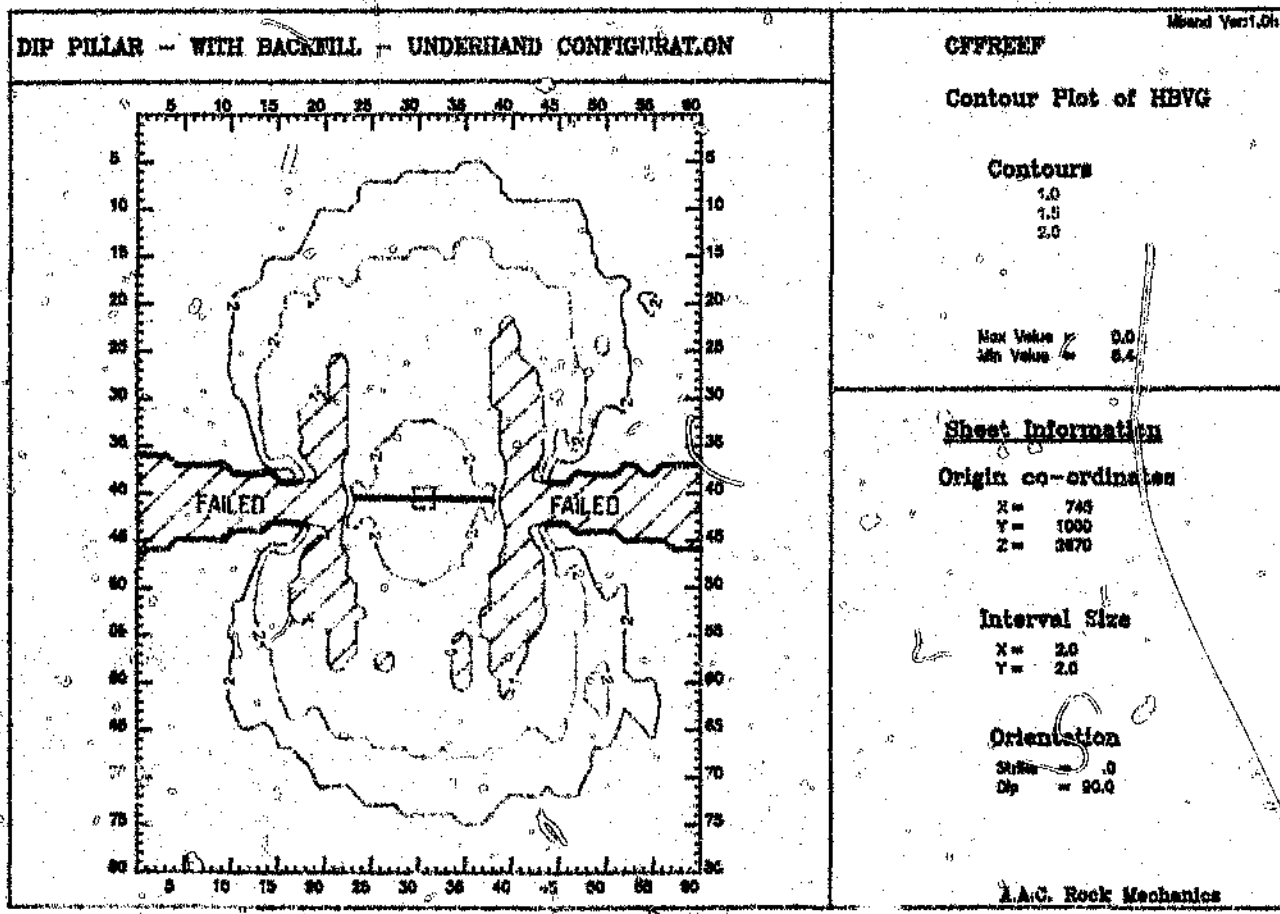

FIGURE 4.9. FAILURE ZONES FOR DIP PILLAR WITH BACKFILL AND AN UNDERHAND CONFIGURATION

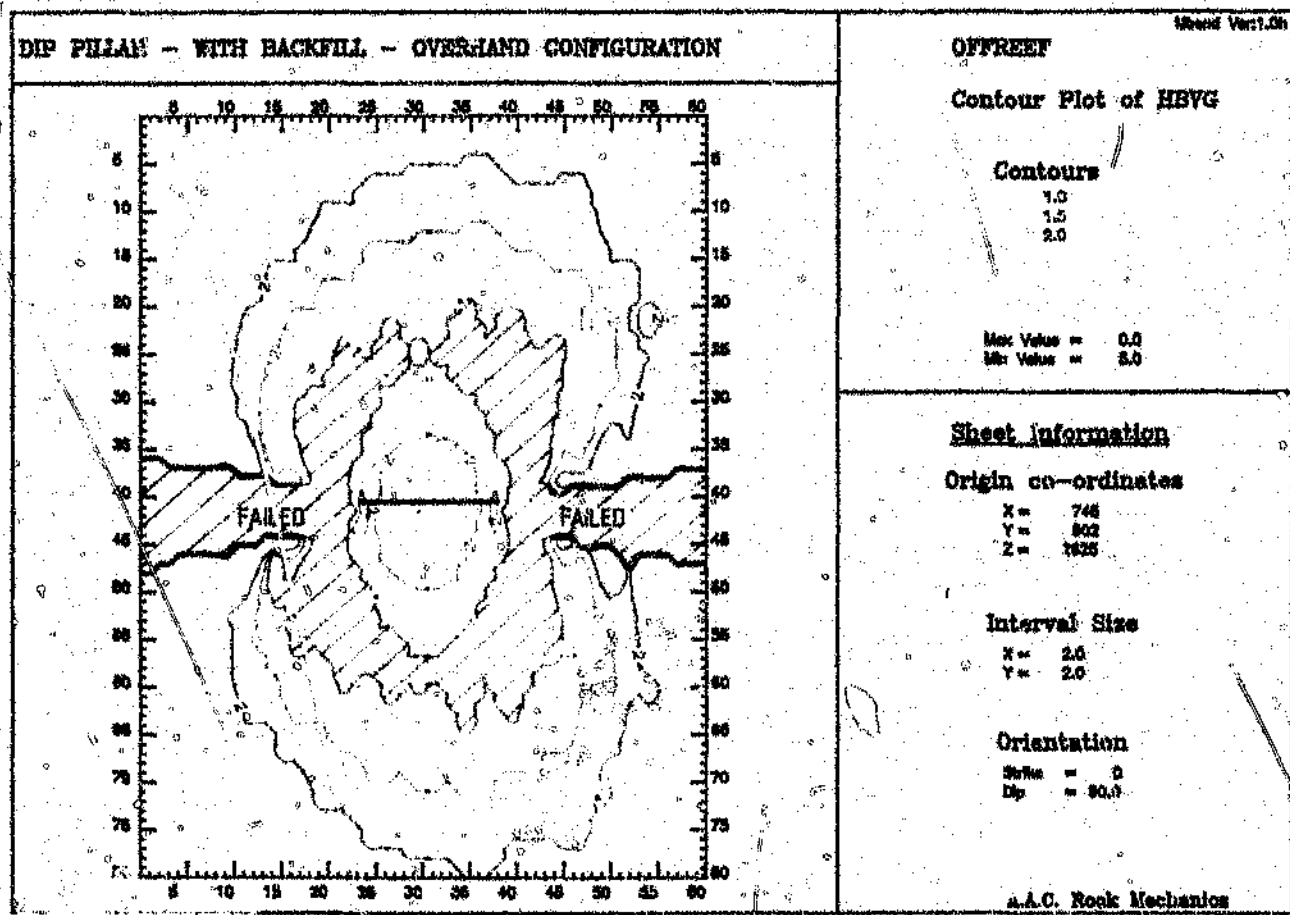

FIGURE 4.10. FAILURE ZONES FOR DIP PILLAR WITH BACKFILL AND AN OVERHAND CONFIGURATION

overall mining sequence in avoiding situations where pillar foundation failure can adversely affect stoping operations.

Worst case modelling (entire coarse window mined out except for pillars) for a dip pillar at 98 level elevation indicates that foundation failure via pillar punching will eventually occur even if classified tailings backfill is utilized. The location and support of the underlying haulages must therefore be designed to cater for seismic activity associated with pillar foundation failure.

4.2 Siting of Footwall Development Beneath Dip Pillars

The haulages for the portion of the mine which will use sequential grid mining are planned to be a minimum of 80 metres below reef. This decision was based on preliminary modelling of maximum principal stress below the dip stabilizing pillars. The maximum acceptable stress level for the design was 120 MPa. This was based on previous experience on Elandsrand Gold Mine which indicated that normal meshing and lacing keeps the haulage in good condition throughout its lifespan, even at 120 MPa. Worst case computer modelling of the maximum principal stress below a dip stabilizing pillar (Figure 4.11) confirmed this haulage positioning.

Designing strictly based on maximum principle stress levels is dangerous because it only deals with the static stress situation. With stabilizing pillars major seismic events due to pillar foundation failure can occur. This results in the haulage being subjected to dynamic stresses (i.e. possible rockburst conditions) which could result in major damage which might include footwall heave. This would obviously be unsafe and would seriously disrupt tramming operations. Assessment of the possible effects of pillar foundation failure on a haulage 80 metres in the footwall will be difficult and has not been addressed in this report. However, until this potential problem area is better understood additional support (long anchors and

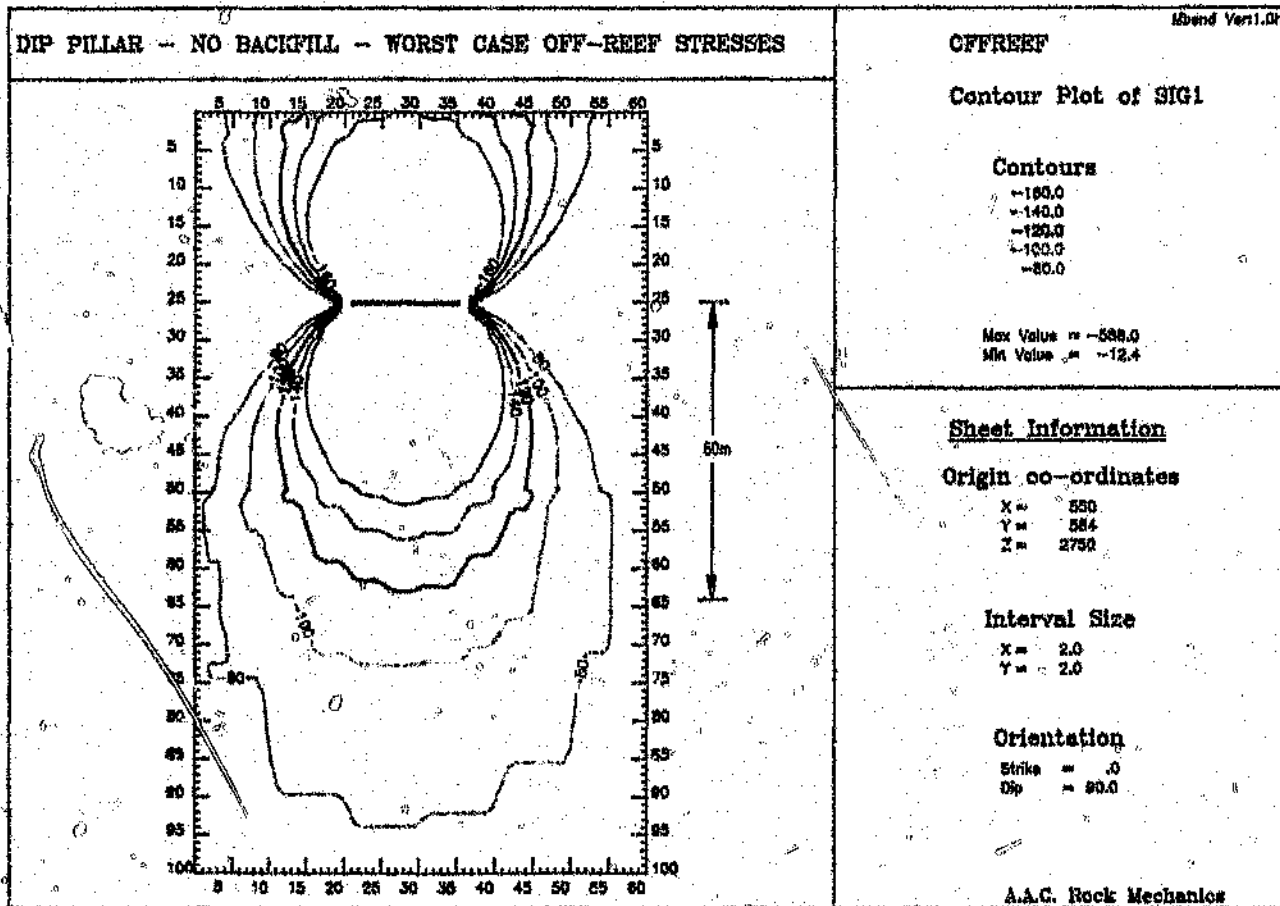

FIGURE 4.11. OFF-REEF STRESSES BELOW DIP PILLAR

post-gunite, also possibly yielding anchors) should be installed in suspect areas under stabilizing pillars. This will be particularly important under bracket pillars due to the potential for failure along the fault or dyke.

4.3 Comparison of the Energy Release Rates for Sequential Grid Mining Versus Scattered Mini-Longwall Mining

The energy release rate (ERR) criterion has lost some credibility as an absolute measure of the acceptability of a mine design. However, it is still generally accepted as an effective criterion for comparing designs, particularly if they are for the same area.

The ERR's for sequential grid mining with underhand and overhand configurations are shown in Figures 4.12 and 4.13, respectively. The ERR's for scattered mini-longwall mining with both configurations are shown in Figure 4.14.

The relatively poor results for sequential grid mining in an overhand configuration below a mined out area emphasize the need to avoid this unless properly placed backfill is used. Backfill reduces the peak ERR for this adverse configuration to 34 megajoules per square metre (MJ/m^2). Historically at Elandsrand the maximum acceptable ERR for any given panel has been 30 MJ/m^2 based on a study of accident rates versus ERR's⁽³⁾ (using a ten metre fine window block size). Modelling with a five metre block size should result in slightly higher ERR's, though this was not checked as part of this report. Areas using classified tailings backfill installed close to the face should also be able to safely tolerate higher ERR's due to the scrata control benefits of backfill. Therefore backfill has a dual effect:

- It reduces the overall stress levels and thus the likelihood of seismic activity.

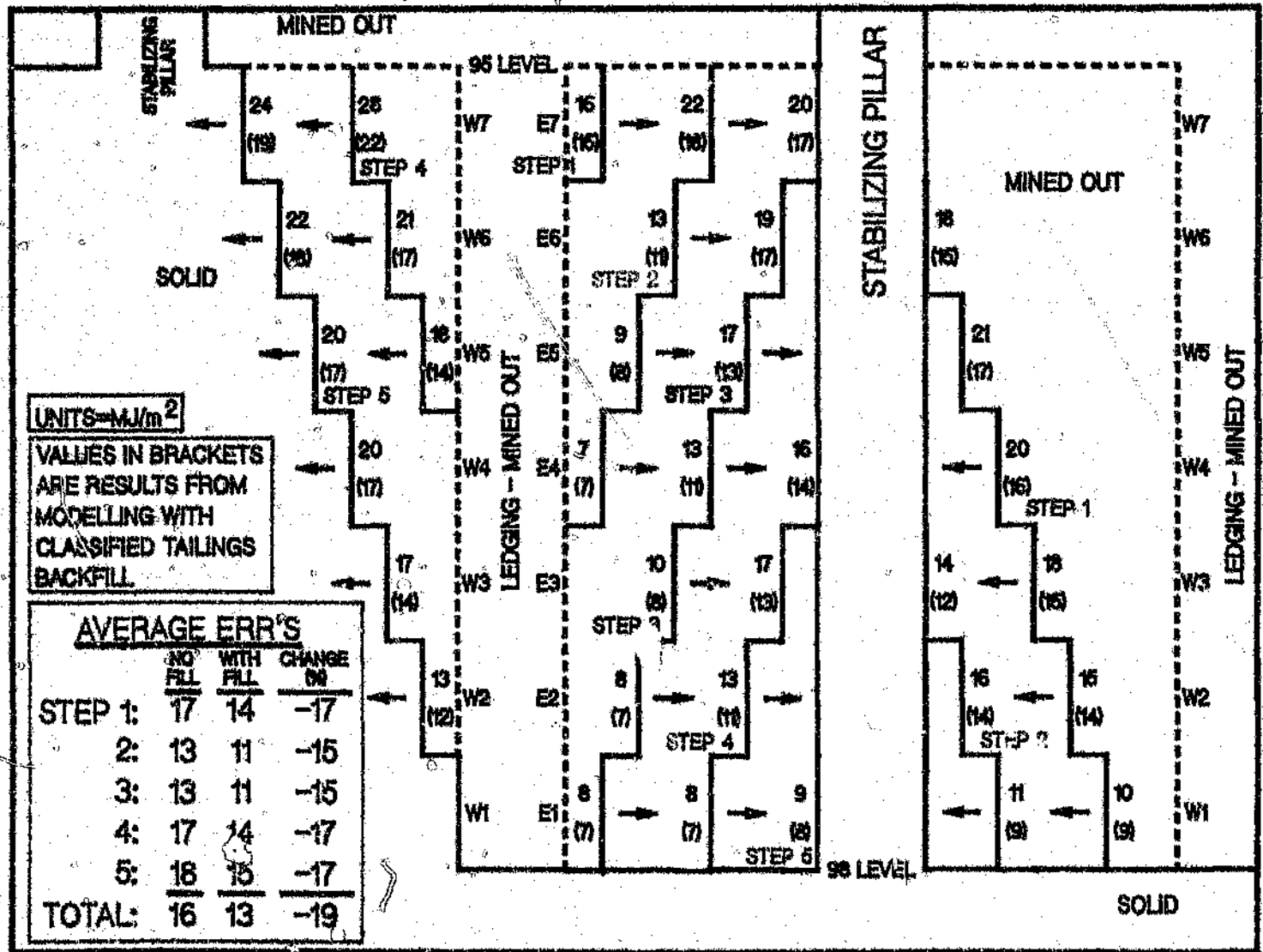

FIGURE 4.12 ENERGY RELEASE RATES FOR SEQUENTIAL GRID MINING WITH AN UNDERHAND CONFIGURATION

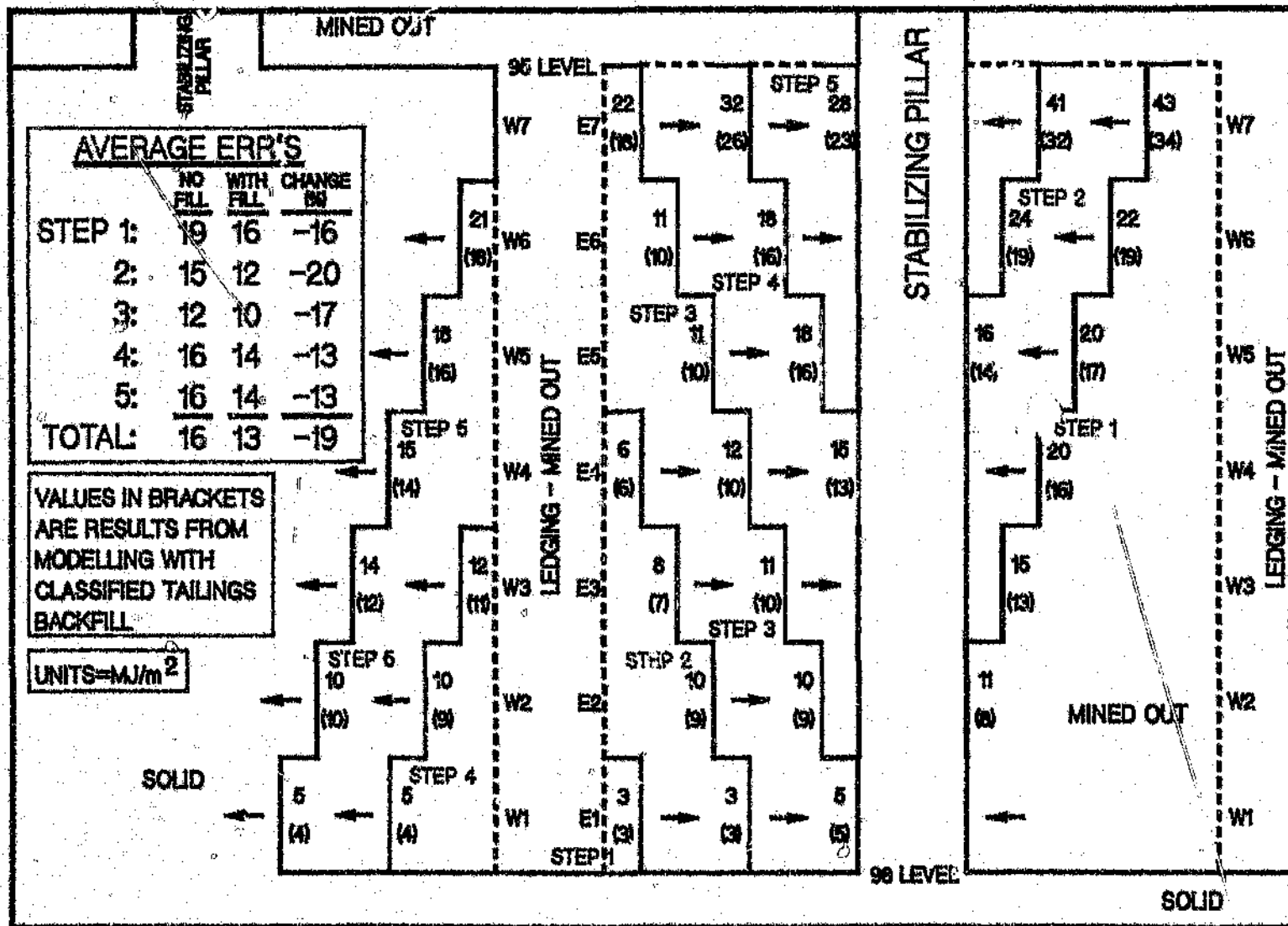

FIGURE 4.13 ENERGY RELEASE RATES FOR SEQUENTIAL GRID MINING WITH AN OVERHAND CONFIGURATION

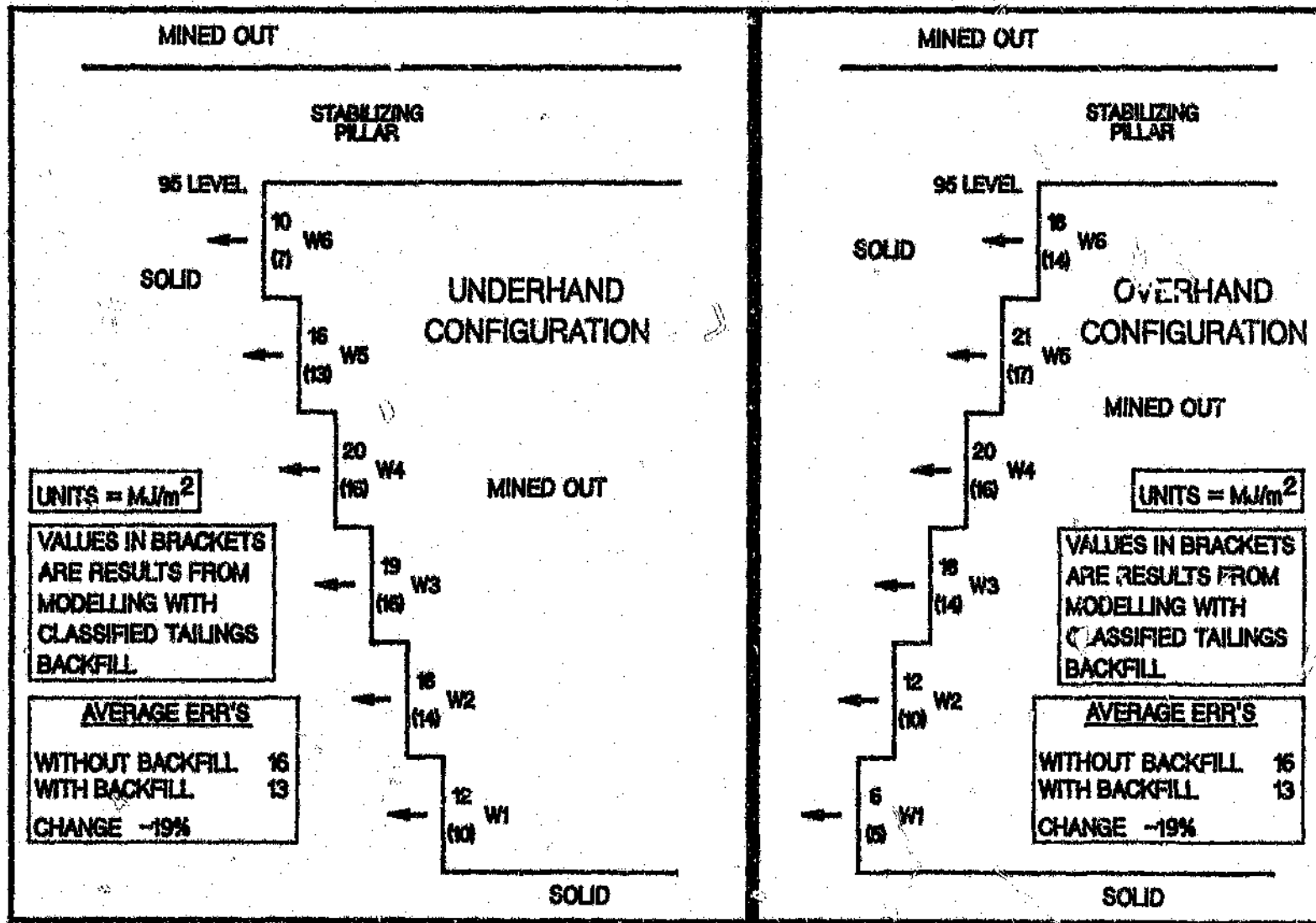

FIGURE 4.14 ENERGY RELEASE RATES FOR SCATTERED MINI-LONGWALL MINING

- It improves conditions so that if a seismic event occurs there is less chance of damage.

The overall average energy release rates for all of the mining configurations were the same. For each configuration the average was 16 MJ/m² without backfill and 13 MJ/m² with backfill. This similarity would be expected since all of the mining is done at the same depth, extraction ratio and approximately the same back length between pillars. The big difference between the layouts is the spread of individual panel values around these averages. Overhand sequential grid mining had the largest variance while underhand scattered mini-longwall mining had the smallest. One benefit of this large variance for sequential grid mining is that a relatively large portion of the mining will be done at very low ERR's.

One major drawback of the energy release rate criterion is that it does not consider the effect of faults or dykes. Monitoring on Elandsrand indicates that a significant portion of the total seismic activity is associated with movement along faults or dykes, often at low ERR levels. This helps to highlight the point that the results of the energy release rate criterion, though useful, are not always valid. For instance it cannot demonstrate the tremendous reduction in seismicity which will result from effective capping of faults and dykes with bracket pillars. The main usefulness of ERR modelling is for rough comparisons of layouts which disregard geological discontinuities.

4.4 Summary of Computer Modelling Results

The average pillar stress for all of the pillars modelled was less than the currently accepted maximum design levels. Therefore, according to this criterion, pillar stability will not be a problem, even without backfill. This is contradicted by the results of the Hoek and Brown failure criterion.

The results of the computer modelling of the Hoek and Brown failure criterion indicate that there is no significant difference in stability between the strike and dip pillars. When mining without backfill was modelled the results indicate that pillar foundation failure can be expected for both pillar orientations. It also appears that this failure could occur at a relatively early stage when stoping is still in progress near the pillar. Classified tailings backfill as modelled significantly improves pillar foundation stability. Failure zones are reduced and it appears that foundation failure will at least be delayed until stoping in the vicinity is complete, provided that acceptable face configurations are maintained.

The planned depth of haulages of 80 metres below reef is sufficient. However, the effect of any large seismic events associated with pillar foundation failure will have to be monitored.

One of the disadvantages of sequential grid mining when compared with scattered mini-longwall mining is that higher energy release rates (ERR's) are encountered during certain mining steps. Perhaps surprisingly, the high ERR's are not encountered as mining approaches the final pillar configuration provided that mining is first done from the raise back to the final pillar position, then from the raise forward to the mining limit for the next pillar. The highest ERR occurs in the panel mining immediately below the mined out area above 95 level (Figures 4.12 and 4.13). This problem is made considerably worse when this top panel is mined last due to an overhand configuration. The scattered mini-longwall layout does not have these problems due to the strike stabilizing pillar between 95 and 98 levels (Figure 4.14). The use of classified tailings backfill reduces ERR's in even the overhand sequential grid mining configuration to what are considered to be acceptable levels for Elandsrand. Proper planning and execution of mining sequences can also keep ERR's to acceptable levels, even without backfill. The use of properly placed classified tailings backfill will, however, allow a great deal more flexibility with mining

sequences. Therefore, while scattered mini-longwalls as modelled result in lower peak ERR's, sequential grid mining can be done at acceptable levels of ERR.

Sequential grid mining therefore meets the rock mechanics requirements for deep level mining. The major concern is pillar foundation failure. At 98 level elevation classified tailings backfill and a correct stoping configuration are required to avoid pillar foundation failure while stoping is in progress in the vicinity of the pillar. Pillar foundation failure will be virtually unavoidable in the long-term after stoping is complete. This could affect the haulages, but their depth in the footwall should be sufficient to dampen the effect of any major seismicity. The other concern is that energy release rates could also reach excessive levels if mining is done with poor face configurations. This can be prevented by disciplined mining with classified tailings backfill.

The maximum acceptable levels for each design criteria need to be more clearly defined because each customized pillar design will have to be checked to ensure that the pillars will have acceptable stability, the overall on-reef stresses are acceptable, excess shear stress is not a problem along faults or dykes, and development is situated in an acceptable stress environment. These maximum levels should be adjusted periodically based on back analysis of results from previous mining. Different maximum levels for design criteria could be used for mining with classified tailings backfill and with cemented backfill. In particular the maximum acceptable levels for energy release rates and excess shear stresses could be higher when backfill is used due to the strata control benefits. Good quality classified tailings backfill installed close to the face will reduce the overall stress levels and therefore seismicity, but it will also reduce the damage due to seismic activity. Therefore it should be possible to maintain safe conditions even if pillars are reduced and more seismicity occurs. Cemented backfill would be expected to have even more benefit regarding strata control.

5 COMPARISON OF SEQUENTIAL GRID MINING TO SCATTERED MINI-LONGWALL MINING

Scattered mini-longwall mining (see proposed layout in Figure 5.1) has been considered as an alternative to conventional longwall mining for Elandsrand Gold Mine. The term "mini-longwall" is used to indicate that each longwall is divided into sections of six panels each, with the sections separated by strike stabilizing pillars. "Scattered" refers to the establishment of a number of longwalls to mine distinct areas separated by major faults or dykes. These major geological discontinuities are left intact and stabilized with bracket pillars.

Scattered mini-longwall mining would be preferable to conventional longwall mining for Elandsrand. However, sequential grid mining is the best option since it will result in improved profitability and safety. The following comparisons between scattered mini-longwall mining and sequential grid mining confirm this statement.

5.1 Production Aspects

- **Off-reef Development Requirements :** Scattered mini-longwall mining would require significantly more off-reef development (see Section 2.4 for details). This would result in much higher mining costs⁽⁵⁾ over the remaining life of the mine.
- **Recovered Grade :** Scattered mini-longwall mining would result in more dilution and more mining of low grade areas. The dilution is due to the need to mine through faults and dykes and to the large amount of waste mining required to overstop shallow footwall development. Longwall mining is not a selective mining method, hence the increased mining of low grade areas. Section 2.4 has details of the improved flexibility and reduced off-reef stoping requirements of sequential grid mining.

ELANDSRAND GOLD MINING COMPANY LIMITED

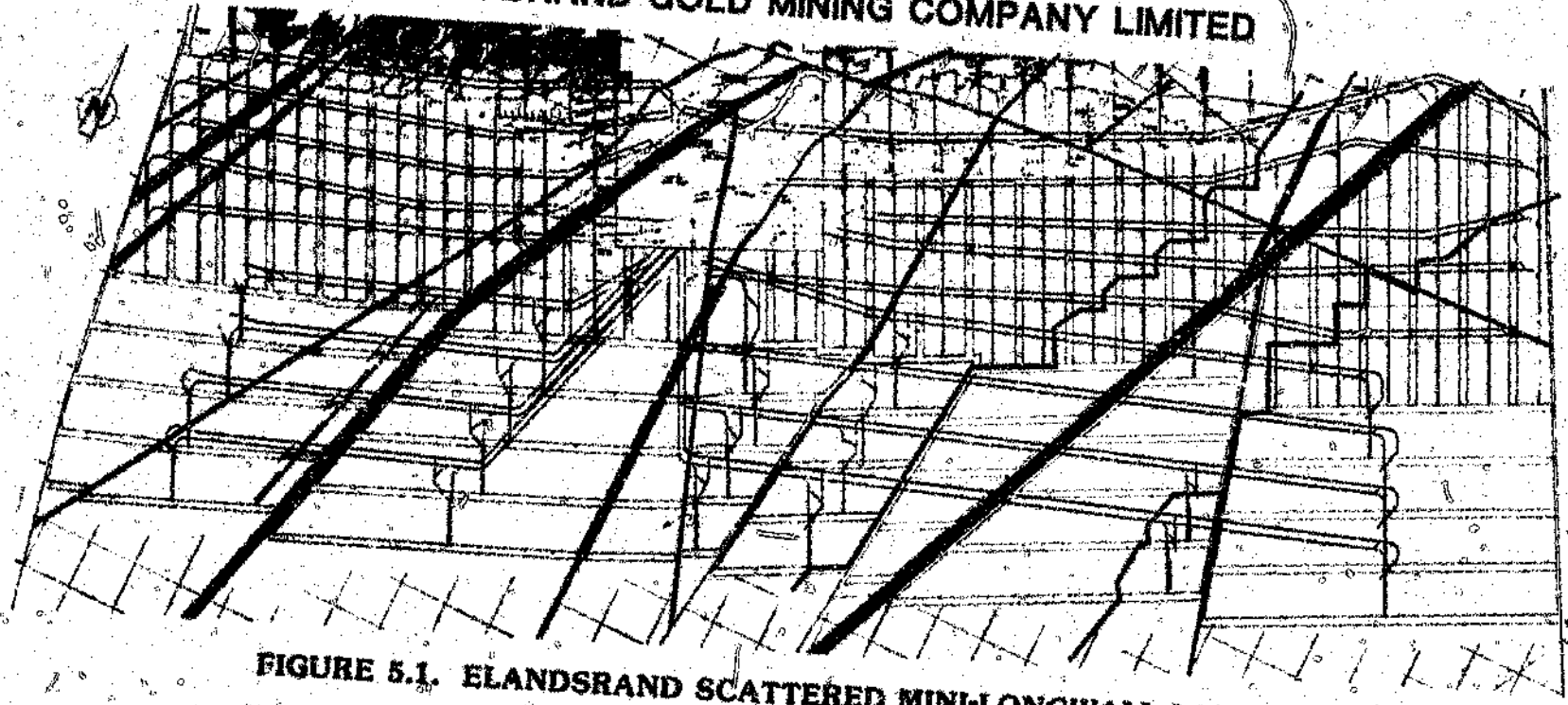

FIGURE 5.1. ELANDSRAND SCATTERED MINI-LONGWALL LAYOUT

- Face Length : Both mining methods would create enough face length to meet Elandsrand's production requirements. However, scattered mini-longwall mining does not allow spare face to be kept available in case there are problems.

5.2 Rock Mechanics Aspects

- Control of Faults and Dykes and Associated Seismicity : Scattered mini-longwall mining allows the major geological discontinuities between longwalls to be left intact with bracket pillars. However, the smaller faults and dykes between these major features still have to be mined through to ensure that the shallow follow-behind development is protected from high stresses. Although the faults and dykes are clamped⁽¹⁰⁾ above and below each mini-longwall by the strike pillars, the unclamped span in between causes major problems. Weakening of the strike pillars also occurs at the intersection with the fault or dyke. This has been a problem area on Western Deep Levels. Details of the improved control of faults and dykes which results from sequential grid mining are presented in Section 3. This improved control will result in a significant reduction in seismicity and a major improvement in safety.

Stability of Footwall Development : Experience with mini-longwalls on Western Deep Levels indicates that pillar foundation failure can severely damage extensive lengths of haulage since the haulages are parallel to the pillars. Several recent large seismic events associated with pillar foundation failure on Western Deep Levels each resulted in more than 100 metres of haulage being damaged. With sequential grid mining the haulages are perpendicular to the pillars. This helps in that it limits the area of potential damage. Therefore the area requiring additional intensive support is smaller, there is less likelihood of someone being in the hazardous area at the time of the event, and if the haulage collapses a shorter length will need to be reopened.

There will also be secondary escapeways available ahead of the area of potential damage by the time the pillar is created.

- On-reef Stresses : Scattered mini-longwall mining does result in lower peak energy release rates. However, this is not a major factor since sequential grid mining can also be done at acceptable energy release rate levels.
- Effectiveness of Backfill : The significant support loads which must be reached before backfill contributes appreciably to regional support are only attained after considerable closure has occurred. Therefore it is the backfill installed midway between stabilizing pillars which contributes the most benefit. For mini-longwall mining the critical area is the middle two panels, while for sequential grid mining it is the area close to the raise. The backfill for the two middle longwall panels is placed in a high closure environment. This means that a significant amount of closure will occur before fill can be placed. The backfill near the raise for sequential grid mining will be installed in a low closure environment. Therefore the fill can be installed at close to the original stoping width. This will result in improved performance of the backfill for regional support purposes.
- Pillar Slots : Strike stabilizing pillars for mini-longwall mining have to be mined through at regular intervals to facilitate ventilation between mini-longwalls and occasionally to overstop an area for a crosscut which has to be developed underneath the pillar. These pillar slots are extremely hazardous⁽¹⁵⁾ because they have to be mined at high stress levels. Pillar slots will not normally be required for sequential grid mining. The exception will be bracket pillars which are not on dip and are therefore situated over a crosscut. These pillars will be slotted during ledging operations, so the mining will be done at low stress levels.

Gully Stability : A particular problem area with strike stabilizing pillars for mini-longwall mining at Western Deep Levels was the gully immediately above the 20 metre wide pillars. A large zone of failed rock(10) in the hangingwall updip of the pillar (Figures 4.6 and 4.7) resulted in a serious problem with falls of ground. This has apparently been solved by increasing the pillar width to 40 metres. Dip stabilizing pillars for sequential grid mining completely avoid any potential problems in this regard because there is no gully adjacent to the pillar.

6 RECOMMENDATIONS FOR FUTURE WORK

Several aspects of sequential grid mining and mine design in general require further investigation or improvement. There are also several aspects of sequential grid mining which need to be monitored during the initial implementation in shallower areas of the mine. This will result in better designs for deeper areas.

- **Computer Modelling to Refine the Design Process :** Designs for specific areas where sequential grid mining is being implemented will improve if further computer modelling investigations are done. More extensive computer modelling needs to be done to assess a wider range of stoping configurations which are possible with sequential grid mining. Different initial conditions (e.g. mined out areas) need to be investigated. The effect of changing the raise spacing or extraction rate (and therefore the pillar width) needs to be looked at in more detail, with due regard to production constraints. The sensitivity of the results to the assumptions regarding backfill modelling parameters needs to be checked as they may have been overly optimistic. The usefulness of inelastic modelling also needs to be investigated.
- **Improve the Monitoring of Seismicity :** The Elandsrand seismic detection and location system needs to be expanded and its accuracy regarding event locations and source mechanisms needs to be improved. Geophones need to be installed in the subshaft as soon as possible to adequately cover the area where sequential grid mining is being implemented. Accurate information regarding event locations and source mechanisms will enable back analysis to be done properly. This will ultimately lead to improved designs for other areas of the mine.
- **Monitor Haulages Under Pillars :** The effect of the dip stabilizing pillars on the underlying haulages needs to be accura-

tely determined. Damage may result from the dynamic deformation associated with seismic activity. Instrumentation and monitoring must be done to determine the extent of the problem (if any) and the effectiveness of various support types in controlling the damage. The effect of dynamic deformation on footwall development needs further investigation. The results of these investigations will result in improved designs for the deeper areas of the mine.

- Improve the Design of Bracket Pillars : This is going to be one of the most difficult aspects of implementing sequential grid mining due to the difficulty of formulating definitive design limits for excess shear stress. However, since sequential grid mining will utilize a relatively large number of bracket pillars there is great potential for learning and improvement. Back analysis of both stable and unstable pillars (determined by monitoring seismic activity) will be vital. Again, experience in the shallower areas of the mine will lead to improved designs for the deeper areas.

- Improve the Economic Aspects of Mine Design : The adverse economic conditions currently prevailing in the South African gold mining industry make it imperative that everyone involved in the planning process pays more attention to economics. The emphasis must be shifted from square metres mined to gold produced profitably. This will require a better understanding of the breakdown of the costs of mining and the effect of changes in planning on these costs. The rock mechanics department must be willing to compare support and mining alternatives to help to determine which set of alternatives yields the best profit while ensuring that mining can still be done safely. Computer modelling will play a key role in determining the size and location of pillars and the planning of the mining between the pillars. It will also help to determine whether it would be more profitable to mine with large pillars and no backfill or to use backfill to minimize pillar requirements. The use of high quality backfill

(probably cemented) needs to be investigated further to determine if it will be a viable option for further reducing pillar requirements in high grade areas. The overall effect of backfill on stabilizing pillars therefore warrants further attention. The possibility that backfill placed in contact with the pillar edges (as can be accomplished with dip pillars) can lead to higher pillar strengths due to improved pillar confinement needs to be investigated.

- **Expand Backfill Capacity and Capability :** The results of the computer modelling indicate that classified tailings backfill will be extremely important for the depth of mining considered. Backfill will help to limit energy release rates to acceptable levels even with less than ideal face configurations, but its biggest benefit will be the improved pillar stability suggested by the results of the Hoek and Brown failure criterion. For the pillar configurations modelled the use of properly placed backfill will allow Stopping operations along a pillar to be completed before pillar foundation failure occurs. This is extremely significant due to the potential severity of rockbursts associated with this foundation failure.

It is therefore imperative that Elandsrand expand its backfill capacity to enable complete filling (with or without cementitious additives) of all panels in areas where the grade justifies the extra expense. The expertise must also be developed now to ensure that this backfill is placed effectively (which means close to the face and in contact with the hangingwall) at all times.

7 SUMMARY AND CONCLUSIONS

7.1 Summary

The objective of this report was to determine the ability of sequential grid mining to meet the rock mechanics requirements for mining the deeper portion of Elandsrand's subshaft reef. The investigation has shown that sequential grid mining achieves the following objectives.

- Stresses and energy release rates can be kept to acceptable levels if properly placed classified tailings backfill and/or ideal mining sequences and configurations are utilized.
- The formation of remnants can be avoided.
- Stabilizing pillars and backfill (in certain areas) will be used for regional support.
- Haulages are situated deep in the footwall to avoid the high stresses under the dip stabilizing pillars.
- Most faults and dykes will be clamped with bracket pillars.

Therefore sequential grid mining can meet the rock mechanics requirements for deep mining. This report has also shown that sequential grid mining is preferable to scattered mini-longwall mining for Elandsrand's variable grade, highly faulted reef.

Sequential grid mining will result in less problems with faults and dykes. This is the biggest advantage of sequential grid mining when compared to any form of longwall mining. There are three main aspects which illustrate the potential for sequential grid mining to reduce the problems created by faults and dykes.

- More Bracket Pillars : Sequential grid mining allows a larger

proportion of the faults and dykes to be left intact with bracket pillars. If these bracket pillars are properly designed seismic activity will be substantially reduced. Bracket pillar design will be easier since more accurate information on the location and orientation of the faults and dykes will be obtained from the development ahead of the stoping operations. These bracket pillars should also be more effective than strike pillars which result in only small areas of the geological discontinuity being clamped.

- **Less Negotiation of Faults and Dykes :** One of the biggest problems associated with longwall mining has been the negotiation of faults and dykes and the re-establishment of stoping operations on the other side of the feature. This is an extremely hazardous procedure which can result in considerable off-reef mining, but it must be done so that the shallow follow-behind development is protected from high stresses. Sequential grid mining will virtually eliminate this requirement.

- **Better Approach to Faults and Dykes :** Sequential grid mining will make it easier to avoid mining a number of panels up to or through a fault or dyke simultaneously. To accomplish this requires prior knowledge of the orientation of the geological feature and the ability to alter mining configurations, sometimes significantly. With longwall mining it is difficult to accurately determine the orientation of geological structure ahead of stoping operations. It is also extremely difficult to make significant changes to mining configurations (e.g. from overhand to underhand) due to the resultant production delays. Sequential grid mining is designed to facilitate both of these requirements.

Sequential grid mining will also result in less problems with footwall development. This is an area which will need to be monitored. However, sequential grid mining will eliminate the need for shallow follow-behind development which runs parallel

to the stabilizing pillars. The haulages for sequential grid mining are deep in the footwall and perpendicular to the dip stabilizing pillars. Therefore, if pillar foundation failure occurs the seismicity will be less likely to damage the haulages, plus a smaller portion of haulage would be affected. This also means that intensive support of haulages in the vicinity of pillars will be more feasible since a small area will need to be protected. Crosscuts will not be a problem since they are overstoped at an early stage.

The ~~design~~ process required for sequential grid mining will result in the Elandsrand Rock Mechanics Department having a vastly increased workload due to the large amount of computer modelling required. The initial layout of dip stabilizing pillars is simple enough, but every time a pillar is moved to clamp a fault or dyke or to incorporate a low grade area computer modelling will have to be done to determine the pillar size and mining sequence required to ensure that all of the design criteria are still met. There will also be a temptation to move pillars whenever it is convenient for production personnel. This will have to be minimized due to the large amount of work required in checking each new layout.

The monitoring and analysis of seismicity will have to improve with regard to location accuracy and determination of the source mechanism. Haulages below pillars will have to be instrumented and monitored to determine if the layout and support are adequate. Additional instrumentation and monitoring will be required to improve the understanding of the effectiveness of a combined backfill and stabilizing pillar layout. All of these operations require substantial additional work from the rock mechanics department.

7.2 Conclusions

Longwall mining with strike stabilizing pillars is acceptable for deep mining when the reef has a uniformly high grade and

relatively little faulting. Sequential grid mining is a safer and more profitable alternative when the reef has a highly variable grade and a relatively large number of faults and dykes, as is the case at Elandsrand Gold Mine. The development done ahead of the stoping operations yields accurate advance information on geological structure and grade. This can then be used for intelligent planning of mining sequences and pillar layouts. Low grade areas where mining would not be profitable can be identified and left as pillars. Bracket pillars can be designed for most faults and dykes. The design and implementation of these bracket pillars will be better since the location, orientation and throw of the fault or dyke will be known well in advance of stoping operations. Where there is no unpay or bracket pillar between raises a dip stabilizing pillar can be utilized to avoid holing and to limit the mining span between pillars. These dip pillars should be shifted to low grade areas whenever possible to maximize gold recovery.

The mining sequence, pillar sizes and pillar locations can be altered as necessary to ensure that the final design meets the relevant rock mechanics requirements. This will ensure that the mining can be done in safe conditions. Backfill will be more effective as regional support between the dip pillars, but it should only be used when economically justified or when necessary to ensure safe conditions. The implementation of sequential grid mining in this manner will allow this variable grade reef to be mined safely and at maximum profitability.

Sequential grid mining will also greatly improve safety by clamping faults and dykes with bracket pillars. The mining of panels through faults and dykes has proven to be an extremely hazardous operation. Sequential grid mining will virtually eliminate this requirement. Properly designed bracket pillars along faults and dykes will also significantly reduce the seismic activity associated with movement along these geological features.

APPENDIX A

INPUT VARIABLES FOR COMPUTER MODELLING

General Elastic Constants

Poisson's Ratio	0,2
Young's Modulus	70,0 GPa
Stoping Width	1,5 metres
Cohesion	5,0 MPa
Angle of Friction	30,0 degrees

Backfill Characteristics

Cohesion	0,0 MPa
Angle of Friction	30,0 degrees
Material Type	Hyperbolic
Critical Stress Parameter ('a')	11,1 MPa
Ultimate Strain ('b')	0,40
Fill Width	1,50 metres
Stoping Width	1,50 metres

Hoek and Brown Failure Criterion Variables(12)

Rockmass Quality	Very Good
Unaxial Compressive Strength	200 MPa
Empirical Constant - m	7,5
Empirical Constant - s	0,1

General Computer Modelling Parameters

Coarse Window Grid Size	20 metres
Fine Window Grid Size	5 metres
Maximum Number of Solution Iterations	15
Successive Over-Relaxation Factor (Second and subsequent Iterations)	1,5
Overall Stress Tolerance	0,2
Maximum Number of Iteration Cycles	15
Successive Over-Relaxation Factor (First Iteration)	1,5
Number of Lumping Shells	3
Iteration Start Control Number	0

REFERENCES

1. An Industry Guide to Methods of Ameliorating the Hazards of Rockfalls and Rockbursts. Chamber of Mines of South Africa Research Organization. Johannesburg, 1988.
2. Muntingh, D.J. and Hamman, J.P.E. A Sedimentological Investigation of the Ventersdorp Contact Reef on Elandsrand Gold Mine. Elandsrand Gold Mining Company Limited Occasional Report, Jan. 1991.
3. Heunis, R. The Development of Rockburst Control Strategies for South African Gold Mines. Journal of the South African Institute of Mining and Metallurgy. April 1980, pp. 139-149.
4. Lavery, R.K. The Effect of Flat Faulting on the Ventersdorp Contact Reef at Elandsrand Gold Mine. Elandsrand Gold Mining Company Limited Occasional Report, 1989.
5. McCarthy, T.F. Production Aspects of Sequential Grid Mining. Elandsrand Gold Mining Company Limited. Unpublished Presentation Material, 1990.
6. Lagerweij, A.W. and Applegate, J.D. Re-assessing the Pillar Design in the Subshaft Area from the 82-21 Line to the 19 Line. Elandsrand Gold Mining Company Limited Internal Memorandum, Oct. 1990.
7. Hagan, T.O. Mine Design Strategies to Combat Rockbursting at a Deep South African Gold Mine. Key Questions in Rock Mechanics: Proceedings of the 29th U.S. Symposium. Balkema, 1988.
8. Hagan, T.O. and Spearing, A.J.S. Modelling of Backfill. Anglo American Internal Memorandum, 1989.

9. Starfield, A.M. and Crouch, S.L. Elastic Analysis of Single Seam Extraction. Proceedings of the 14th U.S. Symposium on Rock Mechanics. American Society of Civil Engineers, 1973.
10. Lenhardt, W.A. Stabilizing Pillars at Great Depth. Rockburst Research Project Report No. RP 146. Anglo American Internal Report, 1990.
11. AAC West Rand Region Guidelines for Reducing the Rockfall and Rockburst Hazard. Compiled by the AAC West Rand Region Rock Mechanics Department, 1988.
12. Napier, J.A.L., Stephansen, S.J. and Johnson, R.A. Supplement to Minsim-D User's Guide Phase III. Research Report 19/86. Chamber of Mines of South Africa Research Organization. Johannesburg, 1986.
13. Lenhardt, W.A. and Hagan, T.O. Observations and Possible Mechanisms of Pillar-Associated Seismicity at Great Depth. International Deep Mining Conference, Johannesburg. South African Institute of Mining and Metallurgy, Symposium Series S10, 1990, pp. 1183-1194.
14. Hagan, T.O. Pillar Foundation Studies at a Deep South African Gold Mine. Proceedings of Conference 'Rockbursts and Seismicity in Mines'. Balkema, 1990, pp. 65-69.
15. Diering, D.H. Regional Support at Western Deep Levels - An Update from 1983 to 1986. Proceedings of the Third AAC Group Mining Symposium. Johannesburg, 1987, pp. 113-126.





Author: Applegate John Oaniel.

Name of thesis: Rock Mechanics Aspects Of Sequential Grid Mining.

PUBLISHER:

University of the Witwatersrand, Johannesburg

©2015

LEGALNOTICES:

Copyright Notice: All materials on the University of the Witwatersrand, Johannesburg Library website are protected by South African copyright law and may not be distributed, transmitted, displayed or otherwise published in any format, without the prior written permission of the copyright owner.

Disclaimer and Terms of Use: Provided that you maintain all copyright and other notices contained therein, you may download material (one machine readable copy and one print copy per page) for your personal and/or educational non-commercial use only.

The University of the Witwatersrand, Johannesburg, is not responsible for any errors or omissions and excludes any and all liability for any errors in or omissions from the information on the Library website.