

**AFFORDING OR CONSTRAINING EPISTEMOLOGICAL  
ACCESS: AN ANALYSIS OF A CASE-BASED APPROACH  
IN A FIRST YEAR PROCESS AND MATERIALS  
ENGINEERING COURSE**

Submitted for the Degree of Master of Education in Tertiary Teaching

Linda Kotta  
May 2006

## **ABSTRACT**

The focus of this study was a case-based approach used in the first year course Introduction to Process and Materials Engineering, PRME1002, at the University of the Witwatersrand in 2005. This approach attempted to promote epistemic access to Process and Materials Engineering by moving away from the more traditional decontextualised and contrived engineering problems and introducing context-rich cases entailing more authentic engineering problems. The study investigated the extent to which the context rich problem-solving environment afforded the students epistemic access to Process and Materials Engineering. This was done through an analysis of the form and content of students' knowledge and problem-solving skills as evidenced in their written responses to case-based problems. A modified form of the Structure of Learning Outcomes (SOLO) taxonomy was used as the instrument of analysis. The research showed that students tended to work in fragmented ways despite the context. They tended not to fully explore the context and as such could not successfully identify the salient aspects. They frequently ignored evidence in the context and invented their own in order to be able to use strategies that they were most familiar with. These findings suggest that while the case-based approach introduced in the course, theoretically has the hallmarks of an ideal approach with which to create a favourable environment for learning, if students treat knowledge as fragmented and aren't persuaded by the context to change their ways of working, the case-based approach does not afford students optimal epistemological access.

### **Key words**

Engineering education

Situated learning

SOLO taxonomy

Authentic Tasks

Problem based learning

## **DECLARATION**

I declare that this research report is my own unaided work. It is submitted for the degree of Master of Education (in the field of Tertiary Teaching), in the University of the Witwatersrand, Johannesburg. It has not been submitted before for any other degree or examination in any other university.

LINDA KOTTA

May 2006

## **ACKNOWLEDGEMENTS**

Without the contributions and support of each of the following people, this research would never have been possible and I extend to them my grateful thanks:

1. Ms Lynne Slonimsky, my supervisor, for sharing her knowledge, experience and expertise, and for her enthusiasm and genuine interest in the work.
2. Mrs Dawn Snell, educational officer and psychologist at the School of Process and Materials Engineering, for her constant support and input.
3. Mr Laurie Woollacott, senior lecturer and course presenter of PRME1002, for making funds available for this research.

# TABLE OF CONTENTS

<b>ABSTRACT .....</b>	<b>2</b>
<b>DECLARATION.....</b>	<b>3</b>
<b>ACKNOWLEDGEMENTS .....</b>	<b>4</b>
<b>TABLE OF CONTENTS .....</b>	<b>5</b>
<b>CHAPTER ONE.....</b>	<b>7</b>
<b>1. INTRODUCTION.....</b>	<b>7</b>
1.1 Background to the study .....	7
1.2 Rationale.....	11
1.3 Research questions.....	12
<b>CHAPTER TWO .....</b>	<b>13</b>
<b>2. THE ENGINEERING CONTEXT .....</b>	<b>13</b>
2.1 Introduction.....	13
2.2 What do engineers do?.....	13
2.3 What is valued in the profession? .....	14
2.4 Engineering problems .....	15
2.5 Engineering education .....	18
<b>CHAPTER THREE .....</b>	<b>24</b>
<b>3. LITERATURE REVIEW .....</b>	<b>24</b>
3.1 Introduction.....	24
3.2 What is the case-based approach?.....	24
3.3 Why the case-based approach? .....	26
3.4 Activities and the learning environment .....	27
3.5 Bases for measure of success of innovations .....	29
3.6 The aims of this particular research .....	30
<b>CHAPTER FOUR .....</b>	<b>32</b>
<b>4. THEORETICAL FRAMEWORK.....</b>	<b>32</b>
4.1 Introduction.....	32
4.2 Learning theories .....	32
4.2.4 Transfer.....	48
4.2.5 The choice of theory .....	51
4.2.6 From theory to metaphor – pedagogical concerns .....	53
<b>CHAPTER FIVE.....</b>	<b>56</b>
<b>5. CONTEXT OF THE STUDY .....</b>	<b>56</b>

5.1 Engineering education and situated learning – The course designer’s perspective .....	56
5.2 Case Study teaching and situated cognition.....	58
5.3 The structure of PRME1002 .....	59
5.4 A Case Study example - Plant on the barge.....	61
<b>CHAPTER SIX.....</b>	<b>64</b>
<b>6. METHODOLOGY .....</b>	<b>64</b>
6.1 Introduction.....	64
6.2 The SOLO Taxonomy .....	64
6.3 The sample.....	67
6.4 Data collection and analysis .....	69
The problem – Question 2 .....	71
<b>CHAPTER SEVEN .....</b>	<b>91</b>
<b>7. ANALYSIS AND DISCUSSION .....</b>	<b>91</b>
7.1 Introduction.....	91
7.2 Results - Question 2.....	94
7.3 Results – Question 4 .....	101
7.4 Results - Question 1 .....	109
7.5 Discussion - Question 2 .....	137
7.6 Discussion – Question 4 .....	141
7.7 Discussion – Question 1 .....	143
7.8 Conclusion - Question 2 .....	144
7.9 Conclusion - Question 4 .....	146
<b>CHAPTER EIGHT.....</b>	<b>148</b>
<b>8. CONCLUSIONS.....</b>	<b>148</b>
8.1 Conclusions.....	148
<b>CHAPTER NINE .....</b>	<b>152</b>
<b>9. LIMITATIONS OF THE STUDY .....</b>	<b>152</b>
<b>REFERENCES .....</b>	<b>153</b>
<b>APPENDIX 1.....</b>	<b>161</b>
<b>APPENDIX 2.....</b>	<b>162</b>
<b>APPENDIX 3.....</b>	<b>182</b>

# CHAPTER ONE

## *1. INTRODUCTION*

### **1.1 Background to the study**

Traditionally engineering courses have been taught in a fundamentals-to-applications approach, where fundamentals constitute theory and concepts, and applications are often contrived problems. The graduates taught in this way emerged with a very strong technical and theoretical foundation but did not necessarily have a realistic idea about solving real problems. Recently however, most engineering schools across the globe have begun to recognise the need to design courses that go beyond the theoretical to design-orientated courses if not hands-on projects (Mourtos and Furman, 2002). In the United States of America, this move has been as a result of the ABET EC 2000 criterion 3 which states that graduating engineers need to be able to design experiments as well as systems, components, or processes to meet desired needs.

Moreover, Mourtos and Furman (2002) report that since the Second World War engineering schools have come under increasing criticism for over-emphasising analytical approaches and engineering science at the expense of design skills. In the South African context, graduates are expected to demonstrate a range of skills and attributes by performing 'procedural design and synthesis of well-defined components or systems to meet specified project requirements, within applicable standards, codes of practice and legislation' (Engineering Standards Generating Body, Project 3, 2002). With design being an element of engineering practice, the gap between engineering sciences and engineering practice may be narrower than has traditionally been the case. The science of engineering, with its emphasis on theory, has been so far removed from the practice of engineering that most companies who employ engineering graduates put them through rigorous 'training programmes' to familiarise the graduates with the inner workings of a real professional engineering environment. Only after this are the graduates deemed ready to join the professional engineering world. The current researcher underwent the same training for two years after graduating.

The move to narrow the gap between engineering science and practice has led to a range of attempts to reform the curriculum. These range from minor pedagogical changes to more substantial changes in course content, pedagogy and intended outcomes. The general trend has been towards collaborative and co-operative learning to promote teamwork, an increased use of technology to reflect a changing society, and the introduction of discipline-specific hands-on project work. In an attempt to bridge the engineering science and practice divide, and to make the practices of an engineering professional explicit to the students, the University of the Witwatersrand in South Africa has made some adjustments to a first year course called Introduction to Process and Materials Engineering (PRME1002), that had up to the year 2003 been taught in the traditional lecture format.

Of all the courses taken by students in first year, PRME1002 has traditionally presented the greatest source of difficulty and anxiety for students. When it was restructured at the beginning of 2001, the changes involved creating a more active and collaborative learning environment and promoting groupwork. The number of lectures given in lecture format in a theatre was reduced to one hour a week and the rest of the contact time was spent in a flat floored venue with students split into groups of four. Assignments and learning tests assessed by tutors were of qualitative and reflective as opposed to the usual emphasis on quantitative problems. The weighting of the final examination was also reduced and greater emphasis was assessment with intensive feedback (Woollacott and Henning, 2004). This reconceptualisation coupled with the course designer's exposure to educational theory led to the design of a case-based approach.

These changes dealt initially with what the course designer (hereinafter Woollacott) termed the problem of 'under-preparedness' and the initial focus was towards developing engineering competencies and academic literacies (Woollacott and Henning, 2004). Four years later the restructured programme was reconceptualised. The focus shifted to developing problem solving skills and to 'get' students to 'think like engineers'. The course designer introduced the changes to address problems in the ways in which students engaged with engineering tasks in the course. The question was how to teach students in

order to enable them to become informed participants in a discourse; essentially how to promote epistemological access (Bak, 1998). The changes therefore came in the way of moving away from traditional lecturing to a case-based approach. This was in addition to group work and all changes introduced in 2001.

A case-based approach in teaching uses case studies to depict real events that students can analyse (Armstrong, 2004). Traditionally definitions of what constitutes a case study vary. Fry et al (1999) see a case study as a complex example which gives insight into the context of a problem as well as illustrating the main point. Davis and Wilcock (2004) have defined a case study as student-centred activity based on a topic that demonstrates theoretical concepts in an applied setting. Woollacott's definition was more in line with the latter definition. More is said on case studies in chapters three and five.

The case-based approach was an attempt at situating the learning of engineering science specific aspects like concepts and principles as well as engineering practice aspects such as decision making within the context of design. It attempted to provide coherent, meaningful, purposeful and authentic activities that represented ordinary practices, thus foregrounding the relevance of the course to the students. For example, in traditional lecture format students learn such concepts as density in a discreet way. For a given problem therefore, if the solution is incorrect, the students do not concern themselves too much as the result has no real significance. In a case-based approach however, if the value chosen to do a certain calculation is wrong it will affect the results of the subsequent stages in the design process, which students can no longer ignore.

According to Woollacott (personal communication) the students' problem solving abilities were compromised by an inability to tap into a wide range of resources in terms of other course work; an inability to use available resources adequately; an inability to read problem situations accurately before embarking upon a solution strategy; and solution strategies that lacked the robustness to illustrate a deep level of engagement. In other words Woollacott attempted to address the fact that they failed to see the relevance of the work in light of their desires to be engineers. Secondly, secondary education did

not encourage them to explore all the resources available to them in solving a problem. Opportunities to look beyond the problem were never provided. This meant that they mostly adopted surface learning approaches that did not prepare them adequately for future learning. According to Henning (2005) part of the reason that students are unable to operate at this level is that they find course work irrelevant and fail to see the connectedness of the material taught.

Woollacott believed that the case based approach was a way of creating an active and cooperative learning environment to promote critical thinking with regard to problem solving. He believed that it was a way to introduce the students to the discipline and practice of Chemical and Metallurgical engineering, to create an environment where students deal with real engineering situations and embark on work that is realistic engineering work and to, in the process, develop the necessary skills of critical thinking, problem solving and content knowledge (personal communication). This approach therefore adopted less lecturing, using lectures instead for support and supplementation such that students could undertake the tasks. Chapter five deals with the case-based approach in more detail.

While the case-based approach has apparent strengths, it has apparently introduced new dynamics among the student, the lecturer, the content, the tasks and the general environment which the traditional method did not. This is not to suggest that the traditional method was ideal, however it points to the fact that the case-based approach may introduce specific kinds of problems. The traditional curriculum and pedagogy, which is part of the entire course, tends to delineate what knowledge is to be learnt, and delivers and assesses that knowledge in separate units or modules. In the case-based approach, the content is embedded within a context and does not make it necessarily clear what content is being learnt. This approach may be generative in the sense that students must be actively involved in identifying and applying knowledge bases in problem solving. However, if the context or elements of it are unfamiliar to the student, the student may lose themselves in the context with the risk of losing out on content and the

associated skills and attitudes. Therefore there are concerns about whether it affords access to the knowledge that it was designed to promote.

This places the problem at the level of epistemological access to knowledge and skills. If the traditional lecture format structure denied access to the knowledge can or does the new innovation change that? As Bruner (1966) notes, “To instruct someone... is not a matter of getting him to commit results to mind. Rather, it is to teach him to participate in the process that makes possible the establishment of knowledge” (p. 561).

## **1.2 Rationale**

I got involved in the first year course PRME1002, at the end of 2003 as a tutor. This was two years after the first restructuring of the course, before the introduction of the case based approach. My involvement raised concerns for me in terms of the ways that students engaged with the material offered by the course and how generally the course seemed to raise the anxiety levels of a number of students. They were having considerable difficulty in trying to negotiate the course content. Some of these students had even obtained very good matric results, but did not manage to pass first year. Most failed or dropped out altogether to pursue other degrees. The course therefore did not seem to be offering them epistemological access. This prompted me to undertake engineering education research at Masters level, looking at how students engage with course material in light of the adjustments. At this time, I was also a teaching assistant.

A widespread view in the faculty on these problems is simply that these students should not have been admitted to an engineering course; that intellectually they were not strong enough to cope with the demands and pressures required of engineering students. Some of these students were at university due to government initiatives to address previous educational inequalities. Their potential was recognised and they were allowed access into the degree. However, the question for me was not whether these students are suited to study engineering or not, but rather, whether they are able to grow and develop intellectually once at the university, by gaining access into the curriculum and the goods that the university offers.

Addressing the issue of ‘meeting students where they are’ does not have to be synonymous with lowered standards. What it does mean however is that faculty must critically rethink and reconceptualise its taken-for-granted assumptions about teaching and learning in engineering and be open to investigations of its curriculum and pedagogy. Therefore, while the issue of increased tertiary access is a step in the right direction in terms of responding to the call for transformation, the next issue on the agenda needs to be that of epistemological access generally, looking at aspects that facilitate, or not, knowledge growth and the development of skills such as critical thinking and problem solving. For the purposes of this research, the course PRME1002, a Process Engineering first year course, will be of interest.

### **1.3 Research questions**

In light of the above problem the research will attempt to address the questions listed below. The first is the main research question, while the others are related sub-questions.

To what extent does the case based approach adopted in the first year course Introduction to Process and Materials Engineering (PRME1002) afford students epistemological access to process engineering?

In order to address this question I shall explore the following sub questions:

- a) In relation to the course PRME1002, what do the students have to be able do and therefore know, for this course and for engineering in general, in order to succeed in the course and in their subsequent degree years? This involves an account of the nature of engineering education and the profession addressed in chapters two and five.
- b) What are the task demands of the problems presented in the cases that are intended to promote the above? The problems are discussed in chapter two.
- c) How do students work with these tasks? This entails an analysis of student responses to tasks.

## **CHAPTER TWO**

### ***2. THE ENGINEERING CONTEXT***

#### **2.1 Introduction**

The following section attempts to define engineering in terms of what engineering is, what it means to know in engineering and what the specific practices of this discourse are. The term discourse is not used in the linguistic sense. Rather what is meant is that the current system of engineering knowledge and ideas (the discourse) was originally and continues to be used to exercise power over the field by categorising engineers as certain ‘types’ (Johnston et al, 1996). This is from the work of Michel Foucault in social theory where the word discourse refers to the way in which institutions name, define and regulate the practices which occur in the name of those institutions. As such there is a tendency for engineers to be classified in a certain way. The current attempts addressed in the preceding chapter to merge engineering science and practice are attempts at freeing what is essentially a ‘captive discourse’, caught in the rigours of traditional science (Johnston et al, 1996). This discussion will focus on both the profession of engineering and engineering education, with the main emphasis being on engineering education. This is presented before the theoretical framework as all constructs that emerge in the theoretical framework are discussed with reference to engineering.

#### **2.2 What do engineers do?**

‘Engineering is a profession; an occupation based on principled scientific knowledge. Its members work closely with scientists and apply new and old scientific effects to produce products and services that people want’ (Shaw, 2001, p. 1). Robinson (1998) captures the essence of the functions of an engineer in the following five points.

- Engineering is applying scientific knowledge and mathematical analysis to the solution of practical problems.
- It usually involves designing and building artifacts.
- It seeks good, and if possible, optimum, solutions, according to well-defined criteria.

- It uses abstract and physical models to represent, understand and interpret the world and its artifacts.
- It applies well-established principles and methods, adapts existing solutions, and uses proven components and tools.

The above foregrounds the key issues of problem solving, the reliance on mathematics and science, as well as methodology or endorsed approaches i.e. the application of principles, the use of models etc. According to Shaw (2001), engineers do creative work. They are skilled in the art of inventing new ways of using the forces of nature to do useful things. Scientists strive to understand nature while engineers aim to produce useful products subject to economic and societal constraints. They deal with reality and usually have a set of specific problems that must be solved to achieve a goal.

### **2.3 What is valued in the profession?**

The skills that are valued most are the associated skills of problem solving and analysis through the competent application of mathematical knowledge and natural sciences. This has to do with the systematic solving of design (the essence of engineering) or production problems (Tonso, 1996b). Also of value are managerial, negotiation and communication skills as these aid in pushing projects through by moving people and resources efficiently. This goes beyond the technical. In some instances technical ability is not essential, but in these cases the engineer is valued for their ability to span the boundaries between engineering disciplines, engineers and non-engineers and with customers. Note that this is an account of what is valued in the profession in general and but not an account of what makes a good engineer. The answer to that question is more contingent on the type of country, the type of company, the type of top managers, the needs, the industry etc.

Design, as alluded to earlier, is often seen as the essence of engineering. It is about exercising knowledge on engineering applications. In design, concepts and technologies are developed to meet human needs. What is valued therefore is the ability to apply the techniques and principles of mathematical modeling to model real life situations, to seek optimal solutions to a range of problems and to make the right judgments and assumptions by combining the modeling skills gained from formal education with

contextual knowledge. It stands to reason therefore that the skills of deductive as well as analogical reasoning, to be defined in the following section, are crucial in these processes and need to be incorporated in pedagogical strategies.

#### **2.4 Engineering problems**

Engineering professionals are often faced and expected to solve ill-structured problems or problems with more than one solution. These problems differ from well-structured problems or puzzles. The latter have only one final solution guaranteed by using a specific procedure (Strohm-Kitchener, 1983). According to Strohm-Kitchener (1983), all the elements necessary for a solution to such problems are knowable and known. Ill-structured problems are those that do not have one unequivocal solution. They often have different yet equally valid conceptualisations and solutions. It is the aim of the engineer to obtain the best solution possible with the resources available (Shaw, 2001).

A criterion for measuring the degree of success of a solution is usually adopted and an attempt is made to optimise the solution relative to this criterion. The engineer rarely achieves the best solution the first time; a design may have to be iterated several times. Engineers are professionally responsible for the safety and performance of their designs. The objective is to solve a given problem with the simplest, safest, most efficient design possible, at the lowest cost (Shaw, 2001).

Engineers solve two types of problems i.e. simple problems and compound problems. In the former, there is often only one criterion with which to evaluate the solution. This criterion or parameter becomes the focus of optimisation. In most cases these types of problems are well-structured in that there is only one solution. Robinson (1998) uses the travelling salesman problem as an example of a simple problem. This problem involves working out the shortest path to visit a number of cities. This may be computationally hard, but because it has a single evaluation criterion (distance) it is a simple problem. In cases where there is more than one criterion, some of these can be quite similar such that they can be jointly optimised.

Optimisation is the process of integration in which efficiency in different areas is traded-off and balanced for maximum effectiveness over the whole. Therefore if criteria are different, increasing the efficiency of one may cause another to be very inefficient thus throwing the whole system out of balance. If they are quite similar, changes in any one of them will not bring changes to the others to the detriment of the whole system. The entire problem then can be reduced to a well-structured one. The choice an engineer makes to 'reduce' an ill-structured problem into a well-structured one has to be explained in a manner that identifies and validates the resultant solution as the best (Robinson, 1998). Robinson calls such explanations 'engineering thinking and rhetoric'.

In a well-structured problem the explanatory framework is deductive. Deductive reasoning is the use of a known law or theory to reach a certain decision or make a certain specific observation. It is thus moving from the general to the particular. In a formal educational setting students reason deductively by making use of abstract concepts encapsulated in 'theory statements' to solve specified problems. This is the fundamentals –to-applications approach alluded to in chapter one. However if the student does not see that the relationships among the criteria are such that the criteria can be reduced into one criterion, the problem will remain an ill-structured one. According to Robinson, engineers solving such problems are thinking more like mathematicians rather than scientists or engineers.

In a compound or ill-structured problem the criteria cannot be lumped or optimised together as there are multiple parameters to be considered. For example problems where engineers are required to balance safety, cost and aesthetics are compound problems. In this case different strategies can be employed to solve the compound problem. The first strategy would be to disqualify the criteria that cannot be measured. If they could be measured then a judgement could be made about their relative importance. This is only valid if their effect is not as important as the effect of the criteria that are retained. The second strategy would be to establish relative values of some of the criteria based on evidence and then reduce the problem to a simple one. This is tantamount to assessing the situation and seeing what's reasonable for that situation. Lastly the problem could simply

be broken down into different parts which are then solved independently. This is tantamount to solving several simple problems. As in a well-structured problem, the engineer would have to provide an explanatory framework to validate the solution obtained from a choice they have made.

The complexity of a compound problem is such that trading off among qualitatively different disciplines is part of the problem. To do this effectively therefore requires a different kind of thinking - a different explanatory framework - that goes beyond or in addition to deductive reasoning. This other type of reasoning is analogical reasoning. In deductive reasoning abstract rules are applied when values of different courses of action can be measured and compared. This is known as the top-down theory to application approach. In the latter type of reasoning the top-down approach may not work, as in design. In this case the weighing of different courses of action can only be done through the use of exemplars (previous designs) by analogy. This approach is known as the sideways precedents-to-application approach where two situations are compared and it is inferred that what is true for the first holds for the second.

The above may sound like it is beyond the scope of students, certainly first year students. That may not necessarily be the case. Most problems that students do in their first two years are simple problems that employ deductive reasoning or the top-down approach. Concepts are called on to solve problems. But as more and more design orientated problems are introduced - the solving of which is contingent on the combination of contextual knowledge and modeling expertise - the students are expected to do more than apply theory, models or concepts to situations. However the fact that the problems students are required to solve are simple in the sense defined above, is not synonymous with easy. In a case-based approach discussed in chapter one, the students are expected to combine their knowledge of concepts etc. with contextual knowledge to solve problems.

## **2.5 Engineering education**

### **2.5.1 The nature of engineering knowledge**

According to Shaw (2001), the formal training of engineers, in the modern sense, is only about 125 years old, and the engineering curriculum has gradually evolved until today it contains subjects that may be divided into the following four categories:

- Science (Physics, Chemistry, and Mathematics)
- Engineering Science
- Applied Engineering
- Humanities and Social Sciences

Engineering science subjects present scientific principles in a way that makes the consequent solving of particular engineering problems manageable. Applied engineering is the heart of problem solving. An example of an applied engineering course is design. Very few new principles are learnt here but the students are trained to solve real world problems. In light of the skills, beyond technical expertise, that are valued by the engineering profession, the importance of the humanities and the social sciences courses is obvious.

Traditionally engineering education has been concerned with the acquisition and application of the large body of relevant knowledge within engineering. The knowledge is considered sophisticated, systematic, complex and coherent. It is a result of formalised, organised and careful reflection and discussion over time by people trying to understand their world (Woollacott and Snell, 2004). Mostly this knowledge is understood by educators to have an independent existence; a body of immaterial objects consisting of abstract conceptual artefacts, existing only in Popper's World 3. Students therefore do not experience the 'realities' but rather the representations of realities or 'text-based realities' (Wertsch, 1991). In other words they operate in activity spaces that are constituted by semiotic means alone (Yael and Slonimsky, 2004).

How do the students work with this knowledge in formal education? Engineers are often known as problem solvers. Even though this skill was mentioned in the context of the engineering profession, the skill and the appropriate tools are first learned at university.

Students there learn to assess situations or gain contextual knowledge, and to then use the appropriate tools to solve the problem. Admittedly, the tools and models are learnt first followed by application where the tools are used in situations. This was described in the previous chapter as the traditional fundamentals-to-applications approach. The students first have to engage with text-based realities, which they then have to bring to bear on situations.

## **2.5.2 The nature of engineering learning tasks**

### **2.5.2.1 The heuristic**

Within formal education settings generally, both secondary and higher education, the problems (learning tasks) solved by students are mostly puzzles. Within engineering, first year students have a fair share of puzzles to solve, most of which have only one solution. However the solution path is never a given. Students have to use principled knowledge to make decisions about the given information and how best to use it to arrive at that solution. Even if there is only one solution to a problem, the problems can usually be approached from different angles and conceptualised differently. This is why engineering tasks in general, but for first year students in particular, present challenges far beyond the level of unfamiliarity of content. Further, since mastery of technical concepts is gained along with the communication skills, these types of problems are necessary to foreground a certain way of thinking. Therefore, although they are puzzles in the sense that there is only one solution, this is not synonymous with ‘easy’ or ‘simple reduction to algorithm’. This is an important point.

Every engineering learning task that students encounter, even of the puzzle nature, requires students to conceive or visualise, define or identify the problem, recognise the concepts, recognise which portions are properties and which are variables and define a balance or apply a representation. To do the above the students have to reflect on all content learnt i.e. refer to their knowledge systems, make decisions and justified assumptions to simplify matters and propose a solution. This method is true whether the problem is well-structured or ill-structured.

To illuminate the nature of engineering learning tasks, the concept of ‘design’ introduced earlier needs to be expanded. In a design one creates systems or processes. Systems are defined as any body or any entity through which change occurs. For example a system could be a section of a plant or it could be a piece of processing equipment. Whatever the choice is, it is up to the engineer to set the physical boundaries. The concepts that operate under the system are derived from fundamental scientific and engineering principles, which include Newton’s laws of motion, and principles of the conservation of mass, energy and momentum.

Each system has properties, which are reflected in a representation. In the most structurally basic sense a representation is an equation that depicts the relationships among system properties and as such allows for the transformation of one variable to another. For example the equation below is a representation:

$$\frac{m}{v} = \rho$$

In the above, the system properties of mass (m) and volume (v) are related in this way to give density. No other relation of these two to give density is valid. In other words a representation such as:  $(m \times v = \rho)$ , would not be valid. Therefore to transform a mass of a substance to volume, one needs the density of that substance. In the bigger sense a representation is a system balance which reflects a conservation principle and helps to keep track of what enters the system, what exits the system and captures the change that happens in between. The balance also contains variables that define the change that happens across that system. Balances are essential and are in fact a tool for design. A balance therefore unlike the representation above can be configured in any way depending on the system. The only rule is that mass, energy and momentum must be conserved, and that if a balance should incorporate representations of the nature shown above, their integrity cannot be compromised. Once the balance has been developed it can be modified and used to the extent to which it defines a certain context. A student working on a problem therefore would have to have a repertoire of these concepts

available in appropriately organised structures and would have to know which to deploy to address a specific situation or to complete a learning task.

#### **2.5.2.2 Functionality**

Most of the concepts taught in engineering are abstract and as such have high cognitive demand. Students require a conceptual basis which secondary education is designed to develop. The concepts addressed in higher education build on these such that if the conceptual basis is weak, the chances of coping with material are slim. This is exacerbated by the pace of the courses. Most problems require the student to do the following (usually in the order given):

- Analyse or identify the problem. In other words, they need to recognise what is salient in the situation, what the statement is and what they are being asked to do.
- Having understood the problem statement, a question of language (both spoken and engineering language), the student needs to unpack the problem, breaking it down to its components.
- The above then leads to conceptualisation, an understanding on an abstract level of what is happening. In other words, information that is not supplied directly but could be inferred from what is supplied.
- Then the student is to apply relevant theory to get to a solution while dealing appropriately with distracters.
- Execution of the solution, which needs to demonstrate logical thought.
- The solution once found needs to be examined for sense. In other words the student needs to be able to tell if a solution obtained makes sense and thus has a better chance of being correct.

Some of the problems (even in the traditional engineering education approach) may be descriptive in an attempt to present real world situations. They reflect the impact the question has on the student's web of related concepts and are communicated across in the discourse of the discipline. Despite this, they tend to be decontextualised. As such when students make decisions in a learning task they are not required to consider the

significance of their solution within a bigger context. This means that there is seldom a real opportunity for the students to develop a reasoned response, which does not encourage critical thinking.

Most of the problems involve solving symbolic numerical representations of engineering situations. An engineering situation needs to be reduced to a formula to derive the answer. This may seem straightforward, however if the concept behind the engineering problem is not grasped, then the reduction will not happen. The problem becomes to identify the nature of the problem and salient information in a mesh of other information given within a problem. To be able to do this however the students need to have understood the governing principles or the underlying concept. In other words, the knowledge base needs to be firm. Davis (1995) explores the notion of knowledge and understanding. He defines 'rich knowledge' as that which has been understood. He then defines understood knowledge as involving true justified beliefs, which are connected, and the connections appreciated by the one who owns such beliefs.

### **2.5.3 PRME1002**

The course demands of PRME1002 in particular are such that the surface learning methods that the students found successful in secondary formal education are no longer effective at tertiary level. In fact the methods that students use in other first year courses, which fall under the category of 'science' i.e. mathematics, chemistry and physics, that they take concurrently with PRME1002 are similar to the methods used in matric. As such first year students at the School of Process pass all these other courses using these methods but find that the methods do not work in PRME1002. This means therefore that they are confronted with what Craig terms 'unfamiliar form' (Craig, 1996), where form refers to the ways in which ideas and knowledge are structured and hence used. For example, if a student has learned to work with formulaic algorithms, then applying a given algorithm to new material would be a case of unfamiliar content, familiar form.

The above process is easier than having to think differently about something one already 'knows'. The latter is unfamiliar form and familiar content. It is therefore easier to think about unfamiliar content in familiar form. This may not lead to knowledge growth but

seems to give students a feeling of comfort. What is necessary to succeed in the PRME1002 and at the tertiary institution in general, is the ability firstly to develop more advanced learning strategies, to modify existing strategies and change any bad habits developed to date. This may involve new ways of thinking, constructing and structuring knowledge. With this in mind, the skill of meta-cognition and epistemic cognition are of great importance.

Earlier reference was made to contextual knowledge and its importance in design problems. This knowledge consists of the givens in a situation, both declared and/or implied. If a student is not able to use their existing knowledge structures to harness other knowledge from the declared, they may not be able to solve the problem. Therefore their existing knowledge structures are an important resource in the process of problem solving. In proposing a solution, the dilemma is deciding which set of theoretical assumptions (the repertoire of concepts) from their existing structure best fit the problem and the evidence at hand (the situation) or how to integrate these into a single solution. The latter is Strohm-Kitchener's (1983) encapsulation of the dilemma in solving ill-structured problems. From the foregoing discussion the cognitive aspect in dealing with course content in PRME1002 is therefore obvious.

## **CHAPTER THREE**

### ***3. LITERATURE REVIEW***

#### **3.1 Introduction**

In this section, I have reviewed some literature on research into case-based approaches as well as approaches that advocate active and cooperative learning within engineering. I have given attention to the following areas:

- a) The definition of a case study
- b) The reasons for using the case-based approach.
- c) The nature of the activities and the learning environments.
- d) The bases used to gauge the success of the innovations or instructional designs.

Although case-based approaches to teaching abound in literature in general, especially in the field of medicine, very few were found specific to teaching first year chemical or materials engineering. Numerous efforts using active and cooperative learning teaching approaches are available however. Those within engineering have been used for senior students where the goals and the student knowledge base are different from those of first year students. As such, most of the case studies used in the case-based approaches have different intentions and different focal points. Three studies are germane to this research and they are discussed below.

#### **3.2 What is the case-based approach?**

According to Bonama (1989) and Grant (1997), the case-based approach is an approach that promotes active learning strategies for students based on case studies. Case studies (or cases) are descriptions of a situation or context in which a problem or a set of issues arises. This approach reflects real world experiences that in turn reflect authentic activities that mirror the experiences of real world practitioners (Bennett et al, 2002). According to some tertiary institutions, a case study as used in a case-based approach is an in-depth exploration of a particular situation to gain a deeper understanding of issues

that are investigated. Barnes et al (1994) contend that analysis of a specific situation forces the student to deal with the 'as is' as opposed to the 'might be'.

Ertmer and Russell (1995) argue that the case-based approach requires students to actively participate in real or imagined problem situations reflecting the kind of experiences naturally encountered in the discipline under study. Students are expected to study the case, and to then identify the general principles that underlie the case. They then test these principles on other case examples for verification of their general validity. Therefore not only do the students develop an understanding of a problem from a holistic point of view, but the method places high demand on their emotional and intellectual involvement. Fry et al (1999) describe case studies as examples which give insight into the context of a problem as well as illustrating the main point. Davis and Wilcock (2004), one of the three studies discussed in this chapter, define case studies as 'student centred activities based on topics that demonstrate theoretical concepts in an applied setting' (p. 1). Their definition covers the variety of approaches they use ranging from short individual case studies to longer group based activities. What all these definitions have in common is that they foreground the value of context, and advocate the development of certain key skills i.e. communication and critical thinking.

The issue of 'real' and 'imagined' situations needs further exploration. The question is if the situations explored are imagined, does this make them less authentic? Authentic tasks are dealt with in chapters 4 and 5; Duguid et al (1989) define them as the ordinary practices of the culture. If an educator adopts the case-based approach as part of trying to get students to 'think like an engineer' for example, should they use real or imagined situations? What constitutes a real or imagined situation? According to Theroux and Kilbane (1994), a real case study is one developed or drawn from factual data and provides a snap shot of an industry. An imagined or hypothetical case study is developed from a compilation of facts or knowledge, and provides an illustrative example that fits the academic content and specific learning objectives of a subject (Barnes et al, 1994).

For example a case study could be developed based on the staff member's research interests. This method makes the process of locating resources easy and the staff member's knowledge is recruited to add to the case study. But due to the fact that the resources remain within the academy and no reference is made to an ongoing or factual data, the situation created by this method is imagined or hypothetical. This way could be used to replace more traditional forms of teaching.

A case study could also be developed based on real examples from industry involving practicing engineers. In this method practicing engineers are invited to present examples from industry (Davis and Wilcock, 2004). Throughout the case study the educator, the engineers and the students are in constant contact. This case study is real. Given these two scenarios, one might be tempted to say that the latter activities are more authentic than the former, which are confined to a lecture theatre.

### **3.3 Why the case-based approach?**

It is widely claimed (Bell and von Lanzener (2000), Gopinath (2004), Kunselman and Johnson (2004), Theroux and Kilbane (2004) that case studies are successful in facilitating students' learning, critical thinking, understanding and problem solving. Jerrard (2005) contends that this approach promotes the ability to develop a reasoned response to circumstances and can be used to encourage critical thinking and the development of skills such as communication and presentation.

Raju (1999) argues that there is growing need for an emphasis to be put on imparting multi-disciplinary education in engineering classrooms. He suggests that this can be achieved by allowing students to solve complex real world problems such as those that they are likely to encounter in the future thus bridging the gap between theory and practice. While he acknowledges that the traditional 'teaching by telling' method may lead to in-depth understanding of content and principles, the students also have to be able to link the theories and the principles to practical problems that occur in real life. He therefore proposes that the case-based approach is a way to communicate real world experience in engineering classrooms.

Davis and Wilcock (2004) have used the case-based approach to teach a materials science and engineering course at a Birmingham university. They argue that case studies encourage active learning, increase the students' enjoyment of the course and provide opportunities for skills such as problem solving, communication and group working to be developed.

In a longitudinal study of engineering students' performance and retention at North Carolina State University, Felder (1995) looked at instructional methods and student responses to them. Prior to this study, he had found that traditional lecture oriented teaching led to poor performance, negative attitudes towards engineering and decreased self-confidence of some of the learners whereas active and cooperative learning methods facilitated the development of a variety of interpersonal and thinking skills. Thus, he introduced active learning into his course called Chemical Process Principles, an introductory chemical engineering course that had 123 students. He did not refer to his method as a case-based approach but rather referred to it as an active and cooperative learning method where he used realistic examples of engineering processes to illustrate basic engineering principles.

### **3.4 Activities and the learning environment**

Raju (1999) worked with senior undergraduate students from an engineering discipline. He developed the case study based on an actual incident that happened at a steam power plant. The students were divided into groups and each group had to address an aspect of the case study. There were no formal lectures because the students were senior students and were expected to refer to the technical knowledge that they had been taught in the previous years. However, academic staff and other resources were available for them to use as they needed. The entire case study was administered over a week at the end of which the students had to give a presentation on their findings.

Davis and Wilcock (2004) used longer case studies, in the order of several weeks. Their case studies were imagined case studies that drew on their research interests. They worked with groups of first and second year students. In their course, they always gave an introductory lecture before the students embarked on the work. On some occasions, the

lecture was followed by other supplementary lectures as the work progressed. One particular case study was about materials selection where students had to make a selection of materials for construction of windsurf masts. The students were asked to use a materials selection chart and to make the selection based on two criteria i.e. density and stiffness. In their selection, the students were asked to consider two designs with different conditions. They had to do some calculations as part of the route to decision making and had to have a good understanding of concepts such as density, stiffness, force and pressure. At the end of each case study student groups had to give presentations. The activities were student-centred and demonstrated theoretical concepts mentioned above on an applied setting. This fits with their definition of a cases study.

Felder's (1995) method was largely a cooperative learning method. He worked with first year students and carried this way of teaching through all the other subsequent engineering courses that he taught. His method involved a change of course presentation and the nature of homework assignments. Instead of the usual fundamentals-to-applications approach that is popular within engineering, he taught inductively, moving from facts and familiar phenomena to theories and models. The homework assignments changed from the usual formula substitution to open ended questions and problem formulation exercises. He presented his course in a lecture series that met twice a week for 75 minutes per session. Additionally, teaching assistants taught several problem solving sessions with students split into groups of 30-40. Each session was a mixture of lecturing, problem solving and small group exercises. The students worked on the exercises in groups of two or four. The exercises had a variety of structures and objectives including;

- (1) Recalling prior material – this involved recalling important points from previous lessons.
- (2) Responding to questions – this involved presenting the groups with questions that probed their choice of solution strategy; whether the choices were valid or not, the reasons that could invalidate the choices and what action could be taken for different problem scenarios.

- (3) Problem solving – this involved giving students other possibly shorter exercises while they were busy with a solution strategy.
- (4) Working through derivations and text material – this involved getting students to understand and explain certain text based solution strategies pertaining to what Felder considered to be important theoretical derivations.
- (5) Analytical, evaluative and creative thinking – this involved, among other things, getting the students to list all stated and hidden assumptions in several problems, and getting the students to use concepts learned to explain every day occurrences.
- (6) Generating questions – this involved getting the students to generate their own questions after a section.

This method did not concentrate on one situation, real or imagined. The lectures did not serve the purpose of equipping students for any particular activity. Instead, there were several activities with different focal points. These activities were timed with each one having a specific endpoint.

### **3.5 Bases for measure of success of innovations**

Of interest, particularly for the purposes of this research, is the means by which the success of the different innovations was measured. Raju (1999) measured the effectiveness of the innovation by asking students to complete a questionnaire. He followed all the proper statistical procedures and according to the results, the students found the case-based approach to be useful, attractive, challenging and clear, and further that it got the students excited about learning engineering subjects. Davis and Wilcock (2004) used questionnaires as well as interviews to evaluate the effectiveness of the innovation. They highlight the importance of assessment used to assess the different aspects of the case-based approach i.e. the development of course content and key skills. They used the formative approach to improve learning and student performance and the summative approach to test student performance against a predetermined standard. Felder (1995) found that the students who were taught in the active and cooperative learning mode improved their grades in general. He concluded that this type of instructional approach worked for all but the least qualified and poorly motivated students.

From the above, it seems that the researchers measured the success of their innovations through the administration of questionnaires. The students indicated whether they had enjoyed the new method or not and gave reasons for the enjoyment or lack thereof. If most students responded positively, with evidence of improved attitudes towards their work, then the innovation was considered to have been a success. Therefore this kind of evaluation of the efficacy of the case-based approach concentrates on subjective measures of success i.e. student attitudes towards their work and levels of motivation, and does not offer a substantive account of the quality of learners' thinking. Consequently, the claims made by these authors about students thinking more effectively as a result of the innovations need to be clarified.

### **3.6 The aims of this particular research**

The above studies have assumed that the students' conceptual skills are enhanced within the context of a real world situation; or rather that they are developed and/or improved. Is this in fact the case? If not, what are the necessary conditions for this to happen? When Felder (1995) states that students improved their symbols, what does that mean? Does that mean they were able to think better because of the 'authentic' nature of the problems he set them? Did they make connections among different situations better? Did the context and the open-endedness of the assignments allow students to integrate knowledge across disciplines? These studies are somewhat silent on the extent to which the case-based approach enhanced the quality and depth of students' knowledge.

The purpose of this study is to develop a deeper understanding of the extent to which the case-based approach affords learners epistemological access to Process and Materials engineering. Thus the points of interest in this study are:

- How do the students think about the problems in this new format?
- How do they approach the problems?
- How does the new innovation with its emphasis on context help, or not, the thinking process and the development of knowledge?

- Does adopting the theory of situated learning mitigate the problems of decontextualisation inherent in engineering education in formal education settings?

To address the above, the nature of the activities or tasks and the structure of PRME1002 will be presented. A sample of nine student responses has been gathered from students' work on an aspect of a case study and will be analysed. This will be done in order to develop a deeper understanding of the extent to which the innovation has helped students to do what Woollacott hoped the case studies would help them do. This includes gaining the necessary skills of critical thinking and problem solving, to move beyond the here and now and think in an integrative manner, to 'tap' into all the resources available (mental and otherwise) and to experience solving a problem that has real meaning.

## **CHAPTER FOUR**

### ***4. THEORETICAL FRAMEWORK***

#### **4.1 Introduction**

Moore (2000) proposes that ‘every educator operates according to a theory or theories of learning and within the context of a philosophy of what education should be fundamentally about’ (p.1). The central purpose of this chapter is to locate the theoretical underpinnings of the course PRME1002, to create a conceptual frame with which to justify the research methodology adopted in this study and to develop a critique of the instructional approach adopted in the course. I shall position the discussion of the theoretical underpinnings of PRME1002 in the context of other learning theories that have been influential in engineering education. These will be discussed to the extent that they inform concerns in the current study (bearing in mind the nature of engineering as has been discussed) and afford conceptual resources for the approach adopted in the analysis of the data.

Chapter two introduced the nature of engineering and characterised the structure of engineering knowledge. The chapter explained the nature of engineering tasks and concepts, as well as an account of what is valued among the members of the general engineering community. This was done to foreground the conceptual nature of the field of engineering and its reliance on mathematics and science. As such, the following theoretical discussion refers quite frequently to the context of engineering to highlight the salient theoretical constructs.

#### **4.2 Learning theories**

Theories of learning can be characterised along a spectrum. The two opposite ends of the spectrum are behaviourism and the situated view, with cognitivism situated in the middle. The three views entail different approaches to learning. Situated learning is the theoretical framework adopted in PRME1002, the first year engineering course mentioned in the introduction. Several issues regarding situated cognition as a theory as well as its suitability in developing ‘an engineering educational model’ (this phrase used in its loosest form), need to be explored.

#### **4.2.1 The Behaviourist view**

For behaviourists, knowing is an organised accumulation of behaviours which have been built up through associations between stimuli, responses and positive reinforcement of those responses. The associated view of learning is about the acquisition of the associations and skills and the focus as evidence for learning is on observable changes in behaviour. The repeatability of these behaviours in similar situations constitutes transfer (Detterman and Sternberg, 1993). Skinner, the most influential behaviourist in the field of education, posits that people learn best by being rewarded for the appropriate responses or for responses that have the potential to lead to right response (Moore, 2000). He proposes that students need to be provided with highly structured materials to work through step by step, proceeding from simpler components to more complex components. These materials should be error free, as errors have the potential to demoralise or demotivate learners. In Skinner's view, learning is hierarchical, linear and procedural. It is about striving to gain mastery of small bits of knowledge; an event and not a process.

I am now going to explore aspects of the cognitive and situated views in more depth. I will start with the concepts from the cognitive view and then turn to a deeper consideration of the situated view, and finally comment on transfer.

#### **4.2.2 The Cognitive view**

The previous chapter pointed to the conceptual nature of engineering knowledge. Therefore the significance of the cognitive view in this research should be obvious. According to the cognitive view, in order to understand concepts and to exhibit general cognitive abilities such as problem solving, one must be able to recognise patterns of symbols and be able to reconfigure symbols into certain patterns (Greeno et al, 1996). Three traditions of research have informed the cognitive view (Greeno et al, 1996). Gestalt psychology is the first tradition and endorses the structuredness of knowledge and posits that organisms structure and organise their knowledge in certain ways. In this tradition problem solving involves looking at the entire structure of the problem and not its parts. The second tradition is the constructivist tradition with Piaget at the helm. This tradition endorses conceptual growth and the notion of equilibration. The last tradition is

the symbolic information processing tradition and it endorses reasoning and focuses on the steps involved in the processing of information for problem solving.

Students' prior knowledge (concepts, principles, procedures etc.) exists in certain interrelated forms. These forms can be likened to structures such that the complexity of the structure depends on the level of interrelatedness among the concepts. These structures either impede or enhance the problem solving process. The procedures for solving the problems are themselves structured and the extent to which a student manages to solve a problem depends on how they have coordinated their structure with the given constraints of the problem. The structures are organisations of concepts. Therefore, a student who has a wide range of related concepts is often able to produce the required solution structure. Conceptual understanding and complexity are therefore crucial in the problem solving process. The outlining of solution strategies which is widely practiced in engineering schools is about characterising or structuring reasoning and problem solving processes. Newell (1980) captured the above well when he stated that a person with a great deal of relevant, well-organised knowledge would be able to solve a new problem efficiently partly by recognising familiar patterns in the new situation. If however the knowledge were not relevant enough or organised enough, the person would have to resort to less specific and hence less reliable methods of problem solving.

Learning in the cognitive view is about acquiring and using conceptual structures. Skemp (1971) has dealt with the notion of conceptual learning. He distinguishes between intelligent learning and habit learning. The latter is a matter of rote recall and the former is about the formation of conceptual structures that are communicated through symbols. He defines conceptual structures as webs of interrelated concepts. These structures serve two purposes: first, they integrate existing knowledge and secondly they serve as mental tools for the acquisition of new knowledge. The structures built during the early learning of a subject will determine the ease with which later topics are learnt. Therefore, if a student's existing structures were incorrectly acquired, such as if they tended to learn more by rote with little understanding or if they learnt things in fragments, the construction of new structures may not happen, as it may not fit into the existing

structure. If the student manages to construct new knowledge and learning does happen that learning will not be lasting.

The development of these concepts is hierarchical in nature i.e. more complex concepts are built on the basis of simpler ones. The simpler concepts are often examples available in one's perceptual field. However, language plays a crucial role in the formation of more complex concepts. According to Skemp (1971) the detaching of concepts from the situations that give rise to them through language helps give rise to higher order concepts. However, language will not necessarily lead to the development of higher order concepts if a learner does not understand the simpler concepts that presuppose the more complicated concept. Therefore, definitions given to teach complicated concepts presuppose an understanding of the simpler concepts.

Skemp suggests therefore that teaching a concept for the first time needs to be done not by definition but rather by example. This is because a definition will require that the learner have the rest of the concepts that are necessarily part of the definition available to them. The difficulty here is that for subjects that teach very abstract concepts, where concepts are symbolic representations that students operate on, the examples that Skemp suggests should be used to teach the concept are often concepts themselves.

According to Greeno et al (1996), the cognitive perspective assumes that transfer is achieved by acquiring an abstract mental representation that designates relations in a structure that is invariant across situations. The issue of transfer is particularly interesting within engineering. It is true that certain representations (as defined in chapter two) i.e.

$$\frac{PV}{RT} = n \qquad \frac{m}{M} = n \qquad \frac{m}{V} = \rho$$

designate relations among the concepts of pressure (P), volume (V), temperature (T) and a certain gas constant (R); between mass of a substance (m) and the molecular weight of that substance (M); and between mass of a substance (m) and its volume (v). 'n' refers to the number of moles of a substance and  $\rho$  is the density of a substance. It is also true that they are all invariant across situations. Failure to apply these in different situations is

frequently a result of failure to interpret situational properties. In other words, the system properties  $m$  and  $v$  (for the third representation) may require derivation from other concepts and conditions that have to be read from the particular system. In engineering therefore, students are rarely required to construct representations as such. They are required to impose already constructed representations in situations whose entailments they have accurately analysed and understood.

The problem of transfer in engineering is therefore more about failure to read the situation such that the proper representations are not used. In other words, students are not able to break the problem into parts and identify the salient aspects. In these situations, Greeno et al (1996) suggest that when a solution path is presented, students need to understand firstly the solution as an example of a general method and secondly that they need to understand the features of the situation that are relevant to the use of the method. Only then will the students be able to learn abilities that they can apply more generally.

Finally, the cognitive view refers to the importance of processes of metacognition or the property of reflecting upon one's own thinking. The steps that were outlined in the engineering problem solving process in chapter two include checking the solution to see that it makes sense and thus has a better chance of being correct. This process has to involve reflection on how the student has thought about what they have put down. This requires a student to do much more than attend to the sequence of steps in a solution. It is clear from the foregoing discussion that within engineering, the cognitive view plays a very important role. More interesting however is the interaction that students need to have with situations, environments, or contexts in order to deploy the available analytic tools (such as representations) appropriately.

#### **4.2.2.1 Structure – mechanisms of reorganisation**

Throughout the foregoing discussion, one word has featured repeatedly starting from the discussion about the nature of engineering and the discussion about the learning theories. This is the notion of structure. Piaget (1970) defined structure as a system of organised and interrelated patterns. This system is necessarily dynamic such that it is able to change

and adapt to varying conditions. According to Moore (2000), Piaget's assertion is that all people interact with the world and construct knowledge through processes known as assimilation and accommodation. This people may interpret the same reality differently due to differences in the internal organisation of their ideas.

Earlier reference was made to the notion of conceptual structures and conceptual learning as an aspect of the cognitive view. Conceptual structures were defined as webs of related concepts. Reference was also made to the importance of existing structures to new learning. According to Skemp (1971) if current structures are found to be inadequate for new situations, the stability of the structure becomes an obstacle for adaptability. What is required is more than the mere assimilation of the new situation; accommodation is required, which is in essence a change of structure.

To elucidate the notions of assimilation and accommodation, consider the following: the way in which people understand things around them exists in their minds in a certain structure. That is, people have inbuilt webs of related concepts. A matric pupil has a certain way in which they understand the concept of density. The parts that form that structure of understanding could be the way in which they were taught density, the extent of their experiences of objects used to demonstrate the concept, the extent to which density was reinforced at home or in settings outside of didactic instruction etc. When the student arrives at university and new pieces of information are presented to them about density, several things happen. Firstly, ideally Piaget says that the comfort of simply adding the new pieces to the old structure is replaced by feelings of discomfort, confusion and frustration, which he calls disequilibrium. When the pieces cannot be fitted to the existing structure, a dead end is reached.

According to Labinowicz (1985), in this case there results a resistance to change, which may lead to a number of returns to unworkable solutions. The feeling of discomfort that is still there however provides the motivation to find a solution. The student then may make a decision to reorganise the current structure to incorporate the new pieces. It may then be possible to add the new pieces such that continuity of the structure is maintained.

This is tantamount to keeping the shape of the structure the same. This maintenance of continuity in response to new input Piaget calls assimilation (Labinowicz, 1985). Not much reorganisation has happened here.

Alternatively, the motivation behind the reorganisation of the existing structure might be novelty and change rather than continuity of the familiar. In this case, the existing parts are reorganised at a higher level with the incorporation of the new pieces such that the resultant structure is a different shape. This process Piaget has called accommodation. Generally then, the student assimilates new environmental input by screening and interpreting it according to their existing network of ideas. This organisation influences to which parts of the environment the student gives attention. The student resists change to the extent that they distort the input or evidence. However the new input continues to stimulate change. At the point that the student realises the limitations of their existing structure, new learning is about to begin (Labinowicz, 1985). The search for a better structure to resolve the discrepancy results in accommodation.

The point therefore is that using Piaget's notions of assimilation and accommodation, one can see that the more complex structures are only achieved through high level restructuring or reorganisation of previous ideas. Therefore, a student's response may have no structure at all. In this case, one can say the student has not engaged with the new input at all for whatever reason. If the structure is there but is simple, it might be that not all the evidence or input has been considered in the process of reorganisation. The student may be trying to preserve the comfort of the familiar. This process is to a level congruent with Craig's (1996) notion of dealing with unfamiliar content (new input or evidence) through familiar form to achieve continuity. If the structure is sufficiently complex, it is likely that the student has accommodated, and in fact has learnt a considerable amount in the process.

#### **4.2.2.2 Equilibration**

Chapter two dealt with the importance of a student's knowledge system or structure and the bearing it has on an engineering problem. What happens when there is a gap between what the student, through his/her knowledge system, has come to expect from a situation,

and what actually happens? This gap according to Piaget is what initiates the processes of equilibration. To compensate, the system creates constructions at several levels. At the lowest level, the student ignores the evidence and treats the disturbance as an anomaly. This is resistance to change. At a higher level, the student begins to reorganise their system and integrates the disturbance as a new variation to the theory (Rowell, 2000). They accommodate the new theory while retaining most of the old. At the highest level, the reorganisation started in the previous level is completed in an internal process of reversible operations such that the disturbance is not eliminated but rather anticipated.

The mechanisms by which this structural change happens as a result of the disequilibrium are of interest. Piaget posits the existence of two separate but interactive cognitive systems (Rowell, 2000). The first system contains concepts and principles and in fact, this is where equilibration happens. The second contains procedures and methods. Most of our students tackle problems by looking to 'plug in a formula and use a procedure'. This works in situations where questions are the same and nothing changes. But for example when a student's understanding of the concept of density is challenged, a breakdown (inability to solve the new problem) is due to the fact that the student has not been able to use the usual procedure that has worked and served them well before. Therefore, the second system can be seen as a tool for re-establishing equilibrium of the first system or a source of possibilities for solutions to new problems.

In solving this new problem then the student would combine the context or the givens of the situation with the procedures as existing in their second system to generate solutions. If the procedures are erroneous, the solutions will be so as well. Therefore, their process of equilibration would need to address questions such as; is this procedure different to what I have tried already? Does the new possibility relate to what I know? Does what my knowledge system anticipate relate better now to what actually happens in the situation? If the student does not ask these questions, they will continue to be in a state of disequilibrium and their first system will remain unchanged. The problem will not be solved and there will be no knowledge growth. The student is likely to invent a new albeit invalid theory to account for a concept.

Although the above gives a 'neat' framework on which to begin to critique students' work, the inherent implication is that for all students, the new input or evidence has the potential to stimulate change to the extent that accommodation and in fact equilibration happens. Whether this actually happens or not will be seen from the analysis of students' responses. From the foregoing discussion, the students' responses could then be classified according to different levels of structural complexity. The reasons behind the lack of structure could then be attributed to variances in the processes of assimilation and accommodation, or to the opposing tendencies toward continuity or change. The variances could also be attributed to mental cognitive structures as they relate to students' stages of intellectual development. The two may even be connected. However, the difficulties associated with the latter are discussed in chapter six.

#### **4.2.2.3 Context**

The next issue of interest that deserves to be carefully considered is the issue of context and/or situation. What constitutes a situation or a context? What are the inherent implications of that decision? Cobb and Bowers (1999) offer a synthesis of the cognitivist's conception of context. This synthesis is in agreement with the insights from the discussion of the cognitive view (section 4.2.2) which alluded to context being primarily the physical constraints presented by a problem, the student's knowledge, the student's conceptual structures, and the structure of a task. What is stressed by this view is the importance of analysing tasks in terms of the components that exist independently of situation or purpose such that the remaining aspects of a context are the instructional setting (Anderson et al, 1996). The latter is ostensibly responsible for the amount of learning or transfer that happens. If in an engineering problem students are given a problem to solve, this view suggests that the system that the students are addressing, its properties and the representations that the students impose on the system all form part of the context. The representations could be mathematical concepts, results from transformations or strategies.

According to Dewey (1938) however, a situation, context or event is not an object. It is an experience of objects and events connected to a contextual whole. Therefore the

properties of a system that a student addresses in an engineering problem solving exercise for example may differ from situation to situation. The experiences will differ across these situations due to the changing properties. In that sense, the student is facing a different moment in time which forms part of a contextual whole whose structure and shape may not be easy to define.

#### **4.2.3 The Situated view**

The third view is the situated view, which sees knowledge as distributed among people and the environment, the tools, artefacts, books and the communities in which they participate. Situated cognition proponents consider it 'a model of dealing with knowledge and learning as fundamentally social and cultural, rather than as artefacts of an individual's journey through an impersonal and objective world' (Kirshner and Whitson, 1997, p. viii). It is a shift from traditional cognitive science which itself evolved from behaviourism where knowledge and learning are seen as resulting from a stable objective world. Situated cognition came about as a result of the dissatisfaction with this view by educators, psychologists, anthropologists and social theorists. The practical concern for education also fuelled the shift towards situated cognition.

The socioculturalists' contribution to situated cognition has been through concern with the appropriation of cultural tools, language and material artefacts. Knowing therefore is about acquiring these cultural tools which they referred to as concepts. The socioculturalists have adopted the use of the word appropriation, where the novice takes something as their own and are comfortable with it, instead of internalisation, where something external is taken into the novice's sphere. They see the former as the use of tools by a novice in an experimental imitation of the culture's usage.

In an attempt to break away from the focus on the individual, situated cognition focuses rather on structures and interrelations within activity systems, and by linking Communities of Practice to broader categories of social analysis. This has been achieved by the socioculturalists' through the idea of appropriation within the Zone of Proximal Development, (hereinafter ZPD). The ZPD is a concept formulated by Vygotsky to represent the difference between what a learner (or student or anyone for that matter) can

achieve independently and what a learner can achieve when provided with assistance. It refers to an interactive system within which people work on a problem, which at least one of them could not, alone, work on effectively. The interaction zone between a student and a more capable other, involves more than just the use of cultural tools by the student as they interact with the environment. A third component there is scaffolding and mediation which when insufficiently provided will not result in the learner achieving any learning.

Within the situated view there is a radical view and a more conservative situated learning view. The radical view 'learning as legitimate peripheral participation' suggests that learning is about participating in a practice under the model of apprenticeship. In this view formal education is not considered ideal in that it does not afford the engagement necessary for individuals to sufficiently immerse themselves in the practice for which they are being trained. According to Greeno et al (1996) successful apprenticeship learning includes modeling, where masters show apprentices how to do a task, and scaffolding where the apprentices are helped as they try to do the work on their own. Lave and Wenger (1991) are the proponents of this somewhat more radical version of the situated view. Their model of the situative view revolves around communities of practice and operates outside formal education settings. This more radical perspective will be dealt with in due course. However there is a somewhat less radical view, which will henceforth be referred to as situated cognition. It values formal education and suggests rather that authentic tasks within formal education be created for students to immerse themselves in. I shall refer to this view as the cognitive apprenticeship model of situated learning.

#### **4.2.3.1 Cognitive apprenticeship**

In recognising that learning a trade is not the same as learning a cognitive subject in formal education settings, Duguid et al (1989) attempted to characterise how the modeling, coaching and fading (i.e. scaffolding) paradigm of apprenticeship might be used in formal education settings. They called this approach 'cognitive apprenticeship'. The apprenticeship aspect of the model foregrounds the centrality of activity in learning and the cognitive aspect foregrounds the cognitive skills associated with conventional formal education as opposed to the physical skills associated with apprenticeship. This

however does not deviate from normal apprenticeship because physical skills are underpinned by very important cognitive skills. Cognitive apprenticeships therefore help transform the culture of formal education such that students can appreciate the purpose of the knowledge they are using, can actively use knowledge as opposed to just receiving it and will learn the varying conditions under which knowledge can be used. The less radical situated cognition view therefore endorses the cognitive but does not rule out participation and interaction.

Duguid et al's (1989) model of cognitive apprenticeship tries to enculturate students into authentic practices through activity and social interaction. In this way the learning potential of apprenticeships is realised within the cognitive domain. The central point here is the development of concepts through authentic activities. This model allows students to acquire, develop and use cognitive tools in an authentic domain. This process entails the modeling of strategies by teachers in authentic activity followed by the support of student attempts through the provision of coaching and scaffolding of the task, and finally the empowering of students by slowly removing scaffolding as students develop competence to independently do the tasks.

Duguid et al (1989) argue that knowledge cannot be separated from the situation in which it is created. They view knowledge as situated, being in part a product of the activity, culture and context in which it is developed and used. They say further that situations co-produce knowledge through activity, that they structure cognition and that learning and cognition are situated. The notion of structuring cognition is interesting and in fact is congruent with the earlier presented engineering problem solving heuristic. The thinking one deploys in solving an engineering problem is a function of the situation or context in which the problem occurs. Duguid et al (1989) further contend that if knowledge is not viewed this way, education defeats its purpose of providing robust knowledge. Their model of learning embeds learning in context by exploiting the cultural and physical contexts.

Duguid et al (1989) recognise the importance of concepts generally but are against the notion of concepts as abstract self-contained entities. They see concepts as neither fixed

nor defined but rather as constantly under construction in the context of culturally situated activity. They suggest that conceptual knowledge is a tool and as such like all tools can only be fully understood through use. Therefore the engineering representations are conceptual tools which can only be understood by applying them in a situation. The tools are used within a culture and therefore using them entails changing one's view of the world and adopting the belief system of the culture in which they are used. Learning then is a process of enculturation. It is therefore not possible to use a tool without understanding the community within which it was created. Herein lies the problem with formal education. Students are often asked to use the conceptual tools of a discipline without adopting the culture. This is partly due to the fact that the culture is not in evidence.

Given therefore that in formal education settings students cannot be given access to the practices that they are expected to learn, Duguid et al (1989) advocate the exposure of students to the use of tools through what they have named authentic activities. This could be especially appropriate for engineering where students learn outside of their target practice. Authentic activities are defined as the ordinary activities of a culture, which issue out ill-structured problems much like those that are presented in much of engineering education. The difference between authentic activity and other more traditional exercises and activities in formal education is that authentic activities follow the same logic of activities in the target practice. They also approximate the kinds of contextual constraints and affordances they work with.

This is in contrast to the usual decontextualised engineering problem, which is supposed to present real problems, but which more often than not bears little or no relationship to any of the coherent activities that real practitioners would engage in. In other words, practitioners would not endorse much of what students do. An exercise in a mathematics problem which has been constructed for instructional purposes is a mathematics exercise, not an engineering one, albeit that engineering activities recruit mathematics. They are not part of the culture of engineering per se but are rather part of the formal education culture. The result of this is that students may misconceive what practitioners do and may

never learn to do the kinds of activities that engineers do. A case in point, most of our students always ask if in fact what they do in class is what 'real' engineers do.

Formal education settings are often considered as centres of abstraction (Bailey, 1993) and Kvale, 1995). Duguid et al (1989) take issue with the notion of Formal education settings as centres for abstraction. They write that 'skills and knowledge have become abstracted from their uses in the real world' (p. 453). This results in the belief that knowledge can be objectified and imparted with no recourse to the communities of practice who value that knowledge. Further, there is no exposure to the mature practices that use the information learnt in formal education, neither is there room for the learners to identify themselves with the appropriate cultures other than that of a student. Cognitive apprenticeships have gone some way in attending to these concerns.

#### **4.2.3.2 The radical situated view**

In her research on apprenticeship, Lave (1997) has compared and contrasted two learning theories i.e. the 'culture of acquisition' and 'understanding in practice'. The former posits that learning is naturally occurring, a cognitive enterprise and quite separate from the process of engaging in doing something. In this view cognitive benefits follow only when the process of learning is applied. Formal education is viewed as the site for decontextualised knowledge, which once abstracted is generalised to 'real world' situations. This would be tantamount to the cognitive view discussed earlier.

Within the more radical situated view understanding in practice is foregrounded in learning apprenticeships and the emphasis is on the notion of practice. The theory assumes that learning, thinking, knowing and understanding are generated in practice. Given the fact that engineering education happens outside of the target practice this notion of thinking, knowing and understanding as generated in practice is problematic. For this notion to be less problematic the problem solving activities that students engage in and the environments in which these activities happen would have to be considered part of a 'practice'. Is this in fact the case? The definition of practice is necessary to clarify this.

Practice in this sense brings the individual to the community where the particular practices are carried out and valued. It therefore rests on the theory of learning where the best learning is seen to happen through the participation in a Community of Practice, (hereinafter, CoP). This definition of practice does not clarify the previous question. It seems to imply that when students are engaged in the activities mentioned in the above paragraph they are part of a community. However the theory does not allow one to get clarity about the members of the community of practice. Would it be a community of engineers in general or a community of the university culture in engineering? And are the activities equally valued in both these settings? Given the differences in engineering as a profession and engineering education, the notion of CoP creates a problem.

CoP is seen by its advocates as a broad theoretical framework for thinking about learning as social participation. Lemke (1997) sees CoP's as networks of interdependent practices and activities. These activities, participation and cognition are bound with the activities, participation and cognition of others, be they people, symbols or tools. The theory explores issues of practice, meaning, community, identity and learning (Wenger, 1998).

The nature of activity in trade apprenticeships, unlike in formal education, can be categorised as on-going. As such, at one point or another there is bound to be conflict. According to Lave (1997) it is this specific character of action-impelling conflict that determines which of the several problems in a situation needs to be solved. Therefore the constraints of a situation determine which aspects are salient. Ironically this same conclusion was reached in the cognitive view discussion. In that discussion attention was drawn to the issue of transfer and the fact that within engineering in a formal education setting most problems of transfer are about the failure on the part of the student to read a situation properly and apply the relevant theory. Reading the situation properly is about knowing the constraints of a situation and knowing which aspects are salient. It seems therefore that although formal education may not create action impelling conflict in the sense meant by Lave, a dilemma is definitely created which requires the student to decide which areas in the situation to attend to.

Lave maintains therefore that activity, or problem solving, is dilemma driven. In formal education on the other hand, it is generally believed that learning must occur 'out of context' and that this should lead to abstraction or generalisable knowledge. The problems that students deal with in this setting are contrived. They do not lead to anything necessarily. Students aren't driven to solve them, there are no dilemmas. This lack of 'dilemmas' or lack of authenticity in the majority of problems students have to deal with results in lack of interest as the students perceive what they do to be irrelevant. Most recent efforts within engineering schools that have gone towards establishing active and cooperative learning environments (outlined in chapter three) have been a reaction to this very sentiment. The trouble with formal education according to Lave is that 'what is learned "out of context" is in danger of being suspended in vacuo' (Lave, 1997, p. 28).

From the above, the central organising metaphors for the cognitive and situated perspectives can be summarised as follows: The cognitive metaphor is that of knowledge as acquired in one setting and conveyed to other task settings. From the insights of the engineering discussion, one has to interact with situations in a certain way such that the use of the knowledge acquired is optimised. The situated metaphor is that of knowing 'as an activity situated with regard to the individual's position in the world of social affairs' (Cobb and Bowers, 1999, p. 5). Therefore the former i.e. the cognitive view operates on both the acquisition and participation metaphors. This is also true for the less radical situated cognition view. The more radical apprenticeship model clearly operates on the participation metaphor only.

Situated theorists deal with the issue of context by introducing the concept of participation in social practice (Lave, 1988; Rogoff, 1995). According to them, individuals can be viewed as participating in social practices even when they are physically isolated from other people. It is interesting to note that this idea is very similar to the notion of negotiated meaning and the fact that negotiated meaning is not contingent on the presence of people or conversations. Lave (1988) and Rogoff (1995) further consider individual actions to be elements of a system of social practices. According to

this view, if context is a function of participation in a social practice, then the context will change as the practice changes and by implication so will the nature of the participation.

#### **4.2.4 Transfer**

One of the strongest arguments against situated cognition with respect to the theory of learning-in-practice is that the new location of learning within the community of practice will deny formal education settings the opportunity for abstractive and reflective learning (Bereiter, 1997). This assumes in fact that abstraction and reflective learning do happen in these settings. The issue is, how does the theory of situated cognition give insight into the likelihood, or not, of transfer?

Bereiter's (1997) view is that in traditional language, the limitations of situatedness are referred to as the problems of transfer. What actually constitutes transfer? According to Detterman and Sternberg (1993), transfer is the degree to which behaviour can be repeated in a new situation. They maintain that transfer is quite rare and if it does happen is the function of the similarity between two situations. The implication is that the more similar two situations are the higher the likelihood of transfer. The trouble here is that in an engineering problem one would have to define 'similar'. Does it mean the context is similar with different parameters? Does it mean one can adopt the same solution strategy? Or does it imply the same visualisation process as a previous problem? Engineering students rarely get similar problems that warrant repeatable behaviour to gain mastery.

Bransford and Schwartz (1999) give a broader view of transfer, which in fact may even be a framework for critiquing the first two views. Bransford and Schwartz have defined two perspectives of transfer. The first is a traditional perspective which they have called the Direct Application of knowledge perspective, (hereinafter DA), where knowledge is a function of 'knowing what' (replicative) and 'knowing how' (applicative). In a nut shell, here something is known and applied. The other perspective, which they endorse, views transfer from the perspective of preparation for future learning, (hereinafter PFL). Here transfer is about letting go of previously held beliefs, ideas, assumptions and easy interpretations. It is more than just about assimilation; it is accommodation through critical analysis, almost a matter of conceptual change. The PFL paradigm assesses the

extent to which peoples' past experiences have prepared them for future learning. Therefore the learning methods referred to in chapter two that students bring with them from secondary education are hard to abandon as they have been validated throughout secondary education. However, these approaches often do not allow students to learn and think in new ways.

Instead of the 'knowing what' and 'knowing how' that are characteristic of the DA perspective, the PFL perspective looks at 'knowing with' (Broudy, 1977). 'Knowing with' emphasizes that along with the artefacts i.e. concepts, formulae etc., one has lived experiences. He writes that educated people think, judge and perceive with all that they have learned in formal education. Knowing with has both an associative and an interpretative function. The former makes associations between situations and the latter allows for categorising, inferencing, grouping and comparing. There is an intentionality in the PFL perspective that is lacking in the DA perspective. 'Knowing with' is about the ability to learn in knowledge rich environments. Therefore if a new engineering problem challenges the current structures that a student has the nature in which the existing structures have been acquired will determine the extent to which the student constructs a new structure and thus learns in the new knowledge rich environment.

The above resonates with Salomon and Perkins' (1989) distinction between low road and high road transfer. The former comes as a result of varied practice with the stimulus characteristics resembling those in the earlier context. Varied practice in a variety of contexts results in automatic triggering of cognitive elements. Within engineering it is not the similarity of the 'stimulus' characteristics to a previous context that triggers cognitive elements. Rather the stimulus characteristics invoke the student's conceptual structures such that cognitive elements begin to operate. Practice on its own in an engineering problem solving would not be very successful due to the wide variety of engineering situations that one might be required to solve. Students may spend hours 'practicing' working on past papers and the like to no avail.

High road transfer on the other hand is mindful and intentional abstraction, where situation attributes, qualities or patterns are extracted and represented by symbols. These abstractions are then necessarily decontextualised and generalised and presumably transferable. Therefore the DA perspective focuses on whether the correct solution has been generated and the PFL focuses on whether people are prepared to learn in new situations. Due to the fact that situated theorists generally do not endorse the notion of transfer most of these definitions have cognitive and behaviourist undertones.

#### **4.2.4.1 Situated cognition and transfer**

According to Bransford and Schwartz (1999) ‘a belief in transfer lies at the heart of our educational system’, (p.61). Why then does transfer sometimes fail? Why is it that what is learned in one situation does not apply to another? Bereiter argues that situated cognition theory would be helpful in understanding why this is so. His argument is that the more that learning progresses, and the more a situation is explored, the less general and the more specialised the behaviours, knowledge and skills. He claims that in this sense it becomes harder to transfer to other situations. Bereiter’s definition of transfer is as follows:

Take situation A, make a symbolic representation of the situation and perform operations on the representation. This process is based on a perceived relationship between A and B and is a mindful act that stems from intentional learning (Bereiter and Scardamalia, 1989). In an engineering tutorial one often finds that students after being immersed in a specific type of problem tend to ‘take’ situation attributes applicable only to that type of problem to different problems. The result are absurd answers that demonstrate that the situation has not been assessed thoroughly enough to judge whether the attributes are applicable to the new situation.

For example, if in an original situation students learn that a filter separates solids from liquids, and they subsequently encounter a new situation where mention is made of a piece of equipment that separates solids from liquids, the students will assume automatically that it is a ‘filter’, even if the new situation has information that shows that the new piece of equipment is not a filter.

The notion of intentional learning implies goals as opposed to strategies. If a student's goal for learning is to finish a set of problems i.e. task completion, that goal is quite different to wanting to learn what the teacher teaches, an instructional goal, and even more different to a knowledge construction agenda. Bereiter argues that the first goal is situated and the last quite general. Therefore as situatedness decreases so abstraction increases. He then defines a situatedness continuum with students located at different points along that continuum.

This idea was rather favourable to me initially. However, what is described above is possibly a learner's orientation, something quite independent of a situation and possibly characteristic of the learner as opposed to the situatedness of a situation. In other words, to an extent, the orientation of a student will make it possible for that student to abstract even in a situation that according to Bereiter is quite situated. Over and above this Bereiter does not make it necessarily clear why he sees the process of abstraction as not situated. The product of abstraction is perhaps not situated but this does not mean that the process is also not situated.

#### **4.2.5 The choice of theory**

The foregoing discussion has raised some important questions for me with regard to the unit of analysis. Situated learning takes the merging of the social and the individual as the unit of analysis. To this end the central tenets of this theory as has been mentioned include participation, practices, the negotiation of meaning, communities of practice, and identity, among others. These all have a social dimension and all assume that for example participation and the negotiation of meaning are socially derived. My concern with this is that the cognitive dimension in these processes may be more pertinent than what these two constructs imply. If one considers that participation, reification, and the negotiation of meaning, are seen as important in learning, there is a real need for further investigation into the role of the cognitive in these processes. After all according to Wenger (1998), participation is both personal and social. It combines doing, thinking, feeling and belonging, and involves the whole person, including bodies, minds and emotions. Further the nature of engineering education is such that the cognitive plays a crucial role to the process of learning engineering.

As a point of departure, I will start with the assumption that in fact situated cognition as a theory is an attempt towards the merging of individual and social constructivism. Further the social aspect of this merger has laid a foundation for the social as a unit of analysis and its role in learning. This is essentially based on the common assumption that the individual as a unit of analysis has been exhaustively done. I include this discussion merely as reminder that if part of successful learning includes participation in practices, and the negotiation of meaning, the individual contributes something to these processes that is not necessarily socially derived. Ordinarily this discussion would possibly be beyond the scope of this research. However the discourse under review is engineering, and given the peculiarities of this discourse, the discussion is important.

Given the fact that participation in practices has a knowledge component, what are the factors that enable learners to construct knowledge? This is not about the nature/nurture debate i.e. it is not about whether learning is about self regulation and the environment providing the conditions for this regulation (nature, often attributed to Piaget) or whether the environment plays a more important role in shaping and influencing learning (nurture, Vygotskyan perspective). Both views do acknowledge the interplay between the individual and his environment.

The question is about whether it is realistic or even practical, pedagogically speaking, to separate the camps. Does subscribing to the situated camp imply total and utter abandonment and rejection of all investigations that focus on the individual processes as they happen during learning? This question is not necessarily new and numerous successful attempts have been made that justify the wisdom of 'straddling both camps'. However, I want to make this discussion my own, to situate it, and to illustrate for the purposes of this particular research why both theories have such great value.

Towards the above end I want to suggest that a) adopting situated learning as a framework for one's teaching should not exclude the individual as a unit of analysis and b) that in engineering education in particular this is crucial. Engineering, as has already

been discussed, is a field that relies heavily on the application of principled knowledge, which is knowledge about objectively defined standards, concepts, algorithms and analytical models, their explanatory bases and why they work. The students of engineering, unlike apprentices who learn the practice as they do it, learn engineering outside of their target practice. As such the knowledge they emerge with, as sophisticated as it is, forms only part of what it means to be a participant in an engineering practice.

#### **4.2.6 From theory to metaphor – pedagogical concerns**

Earlier I differentiated between the different schools of thought with regard to knowledge and learning. Due to the view of knowledge held by the cognitive camp, teaching often happens in a de-contextualised and disembedded manner. This process is highly problematic as it ‘ruptures already de-contextualised knowledge even further by removing it from its moorings in coherent knowledge and practices (Slonimsky and Shalem, p. 98, 2004). The view of knowledge held by situated theorists on the other hand results in teaching that endorses collaborative and cooperative learning approaches. This camp also endorses authentic activities or activities situated in the kind of problems traditionally addressed by academics and professionals (ibid.).

If one views learning as participating in a community of practice where students contribute to the advancement of the practice and learn to become part of the whole, the importance of the individual contributions made by the students as participants is obvious. Not all information that comes to students is received and assimilated in the same way, just as no two people react to the same information similarly. Thus one should give due attention to the individual cognitive monitoring processes that students engage in.

The above argument may be better understood if the two camps are dealt with at the level of metaphor rather than theory. Sfard (1998) talks about two metaphors for learning i.e. the Acquisition metaphor (AM) and the Participation metaphor (PM). According to Sfard, these are the tacit assumptions that guide the fundamental primary levels of our scientific thinking and formal theorising as well as our intuitive and spontaneous concepts. They inform what learners and teachers do, and how we theorise about learning. The AM is

about the construction or development of a 'self-sustained' entity. The entity can be a concept, knowledge, meaning, schema, conception, representation etc., and can be acquired through internalisation, assimilation, construction, development, attainment, appropriation and so on. Concepts in this metaphor are basic units of knowledge that can be accumulated to form more complex cognitive structures.

Within the PM, the words 'concept' and 'knowledge' do not exist as separate entities per se. They are replaced by verbs such as 'knowing', doing and having, the last having a certain permanence. While in the AM the words concept and knowledge have a clear end point, the processes involved within the PM are ongoing. Activities in this metaphor are fused with contexts in which they happen. The new key words are situatedness, cultural embeddedness, practice and community, and learning is about participating in activities and about becoming part of a whole (Sfard, 1998).

Sfard stresses that 'the dichotomy between the acquisition and participation should not be mistaken for the well known distinction between individualist and social perspectives on learning' (p. 7). For example, theories on knowledge reception and internalisation of socially established concepts both fall under the AM, but fall under different groups in the individual/social divide. If therefore at the most fundamental level, there are overlaps in the central tenets of the apparently opposing theories, it is easy to see how separating them could be problematic. Sfard makes a case for the inseparability of the two metaphors and how in fact 'the act of acquisition is often tantamount to the act of becoming a participant' (p. 6). She argues further for the inherent impossibility of freeing the discourse on learning from either of the two metaphors.

The two metaphors possibly even make each of the theories more robust. If for example one views learning as participating in a community of practice and sees students as having a key role in growing the practice, then according to the AM the individual mind and what goes into it being the focus will help highlight and even refine that which the individual brings to the participation. According to the PM, the evolving bond between the individual and others is made richer by the inherent differences of the individuals and

consequent consolidation of contributions. By very nature, learning is such that the whole and the parts inform each other, both at the level of learner (the part) and community of practice (the whole), and at the level of individual tasks (the part) and the entire practice (the whole).

Further, while in the PM the identity of a person rests in their possession of an entity, be it knowledge, a concept etc., in the PM the identity is a function of being part of a greater whole. However, by implication being part of a greater whole includes not just the student or person but also includes all that they possess (by way of knowledge or concepts etc.). The introduction of an interaction space where the individual and others meet may lead to the making of new constructions. However, this process is not a matter of creating ‘something out of nothing’. Participation makes certain functions and operations necessary and as they participate, students embark on goal directed actions executed through cognitive structures. Even if mental functions are transformed social interactions students still have the task of making those mental functions their own ‘by integrating them into their reservoir of knowledge (intra-psychological functions) and generating new thoughts and actions on the basis of them’ (Slonimsky and Shalem, 2004, p.87).

Arguing against neglecting the individual as the unit of analysis within socio-cultural theories does not mean that one engages in processes that attempt to define and measure the cognitive structures of individuals. However, it does require the definition of the cognitive operations and cognitive monitoring processes that individuals must engage in during tasks. It must also be acknowledged that engineering students have to be able to perform certain operations (which the tasks then define) before they can do operations that are more complex and integrate at a higher level.

## CHAPTER FIVE

### *5. CONTEXT OF THE STUDY*

#### **5.1 Engineering education and situated learning – The course designer’s perspective**

In chapter two, the nature of engineering, the tasks as well as functionality were discussed. Since the theory of interest is situated cognition as it is adopted in the course PRME1002, Woollacott’s perspective on the link between situated theory and engineering education needs to be given. This link captures his assumptions about instructional design. The point of interest will be to see how he has merged his conceptualisation of engineering with issues pertinent to situated cognition.

From Lave and Wenger’s theory of learning as participation in communities of practice Woollacott and Snell (2004) claim that learning happens best through participation. According to this idea knowledge finds its meaning within the context in which it is used and therefore has to be learned in contexts that give that knowledge meaning. From this premise they make several points. Firstly, engineering learning environments have to be authentic to actual practice through bringing a full range of knowledge embedded in practice. This would give rise to the correct cues and sensitivities.

Secondly, university education systems are communities of practice. This means that there are practices and cultures that are peculiar to tertiary study, that are different from engineering CoP. If learning is a process of enculturation, then this culture that students participate in has implications on the learning that happens. Thirdly, the participation in the culture and practices has to be legitimate i.e. involves engagement with authentic aspects of practice in authentic settings, and peripheral i.e. the learner does not have the expertise to participate fully in the practice yet but is on a trajectory towards full participation. The latter implies the presence of experts and working at their elbows (Woollacott and Snell, 2004).

These three points seem to have merged the less radical situated cognition view as exemplified by authentic practices or tasks and the more radical perspective that endorses

communities of practice. As such these points raise several concerns. Most students do not learn engineering to become lecturers necessarily. Therefore the idea of legitimate peripheral participation is problematic because it is not obvious who the experts are. If students were being taught to become engineering educators the educators would be the experts. The point has been adequately made that engineering students learn engineering outside of their target practice and that the profession and the education are not necessarily the same. It is therefore not clear how the idea of a community of practice (as opposed to authentic tasks) within an engineering education setting would enrich the education process.

Woollacott and Snell (*ibid.*) further define engineering education as ‘enculturation into the practice of professional knowledge-work at the interface between material and immaterial technology’, (p.14). They maintain that professional knowledge work is generic across all communities of engineering practice and has three components:

- (1) Abstraction work – This facilitates a means of escaping the particularities of presenting situations by generalising context-specific information into context-general information that can be manipulated using theory.
- (2) Elaboration work – this enriches the resources available in presenting situations by elaborating context-general knowledge to appropriate context-specific information.
- (3) Integration work – this interconnects information and productive activity and involves the integration of context-general and context-specific information in productive ways consistent with professional conduct.

In Woollacott and Snell’s definition immaterial technology refers to the general body of engineering knowledge and material technology refers to the application of engineering knowledge. The above three components capture the skills that the students are expected to develop during participation in authentic activities. The implication seems to be that the students have to straddle the two communities of practice as endorsed by both the

tertiary education culture and the professional engineering culture. As a result of the above view Woollacott introduced the case-based approach to the course PRME1002.

He makes the following assumptions about case studies:

- (1) Case studies allow for an introduction to the disciplines of chemical and metallurgical engineering.
- (2) During the case studies the students will be faced with real engineering situations and will have to do work that is realistic engineering work.
- (3) As they do the work, they will develop the necessary technical skills and knowledge.

## **5.2 Case Study teaching and situated cognition**

Case study teaching was used by Woollacott as a way of structuring instruction by designing an authentic learning environment to make engineering knowledge and the practice as a whole more accessible to the students. In essence therefore he tried to create authentic settings and give authentic activities. To capture his efforts in light of Duguid et al's (1989) discussion, he wanted to give the students the opportunity to engage the relevant domain culture. He tried to demonstrate the use of the domain's conceptual tools in authentic activity. The first case study that was used in the course is discussed in some detail below. Reference is made to the others but the salient features are the same.

Authentic activities can be achieved in several ways namely project and problem based learning. The primary aim is to sensitise the students to the logic of the practice as a whole. In the Case Study mode, the 'whole' is made up of sub tasks with the idea that as students engage with the tasks they bear in mind the 'contextual whole'. This is designed to develop mastery that is authentic by making the tasks less contrived. It is also a way of getting students to feel that they are contributing to something of real value. Even though the students sit in groups and the tasks have been presented in a way that makes the bigger picture more explicit, the level of individual functionality as defined in chapter two does not change.

### 5.3 The structure of PRME1002

As mentioned earlier the purpose of this research is to evaluate the claim as made by Woollacott about the case-based approach to teaching; that it is a way of structuring instruction by designing an authentic setting such that engineering knowledge and skills are more accessible to the students. Seen this way the course PRME1002 becomes a bigger structure incorporating the constituents of both engineering knowledge (the structure of knowing) and the student, in a whole. This can be represented schematically as in fig. 1 below

Figure 1



The case study brings the student into a relation with the engineering knowledge in a certain pedagogical structure including the context, the sub tasks, the group work and the method of evaluation. The engineering knowledge square is a structure whose parts are the different disciplines that inform engineering and give it its shape i.e. maths, chemistry, physics, economics, business, ethics etc., represented by the little circles. The student square is a structure whose parts are made up of, among other things, what the student knows, their existing conceptual structures, their dispositions, orientations, cultural backgrounds and so on. If a course designer therefore held a different view of learning, their structuring would be different. That is to say the parts i.e. the assessment, the sub tasks, the learning environment etc., would be arranged differently and possibly the label of the structuring would change from 'case study' to something else. The

previous sections have dealt with both the structure of knowing i.e. the engineering knowledge and tasks, and the structuring in terms of the course. What has not been dealt with is the student.

The case studies were created such that they were contexts for authentic activity where certain learning would happen through participation. Woollacott was working on the assumption that the students were all 'at the same place' in that none of them had ever dealt or encountered any of the situations before. This was problematic since the nature of some of the physical aspects the context created implied cultural and social nuances quite unrelated to prior knowledge gained through explicit teaching. On this basis, the students were not at the same level. The context created differential access through its conditions. For example the notion of a barge was quite foreign to some of the Black students. The fact of it floating down the river was beyond their experience.

The case studies were developmental in nature. In other words they were broken down into different learning tasks that students had to attend to. In this way each task had bearing on the following tasks such that ideally the students developed an appreciation for the importance of the problem solving process, the implications of their assumptions and solutions, as well as the role of the learning tasks as part of a bigger picture. The students were allocated to groups with four members per group. They stayed in their groups for discussion purposes but had to do individual consolidation for assessment purposes.

In the bigger sense, the entire case study constitutes a context as is defined by the situated learning theory. However the subtasks that formed part of the case study may be viewed differently. The way in which these subtasks were structured was key and the elements of knowledge that were necessary for successful completion of those tasks are a combination of students' existing knowledge systems which have a tendency to pre-orientate the solution strategies, components that exist independently of the situation, as well as the physical constraints of the specific situation. In light of the purposes of case study teaching mentioned earlier it appears that to enjoy the full benefits of the case study

in terms of educational value requires that context be viewed as more than just the background information but as including the structure of the subtasks, the group work environment and the knowledge structures of the student. This encompasses both the cognitive and situated views on context. It is clear that for students to reap the full benefits of the authentic setting created by the case study they need to fully participate in the learning tasks, which include the ‘independently existing components’.

A typical week consisted of two lecture periods and two ‘discussion’ periods during which all the group work was done. The students were split into two groups for tutorials with the groups coming on different days. This was done to make the best use of the available resources in terms of tutors. The lecture periods were used for consolidation and theory input. The lectures were almost always given after the students had completed a portion of the work. This was done to give students the chance to work through the cases on their own and get a chance to reform their thinking or reconstruct first, before input was given. The intention was that the students, especially the good ones, would frame questions beforehand which they would raise during the lecture, and thus would be aware of the learning taking place.

If it is understood that the purpose of curriculum design is to facilitate student learning, the question to ask is whether the innovation in PRME1002 affords students the conditions of possibility to learn. This question is addressed not by trying to analyse the mental structure of the student, which is not directly accessible, but rather through looking at the structure of student understanding as reflected by their responses to certain tasks. The instrument used to analyse the responses is known as the Structure of the Observed Learning Outcome (SOLO) taxonomy (Biggs and Collis, 1982). The SOLO is a model for qualitative evaluation of student work. It consists of five levels of increasing structural complexity which include prestructural, unistructural, multistructural, relational and extended abstract. The SOLO taxonomy is discussed in chapter six.

#### **5.4 A Case Study example - Plant on the barge**

The first case study was called ‘The plant on the barge’. A plant is a building or location for industrial labour. A barge is a non-self propelled plant of box configuration. It serves

several functions. It can be used as a deck cargo to transport personnel, materials, supplies or equipment. It is sometimes also used for the exposed storage of materials for field operations. To protect personnel the plant may contain a shelter. The plant can also be used as to store or transport kerosene, lube oils or other petroleum products in permanently installed deck tanks. The plant can also be used as a service station and might then contain combustion engines, generators, switchboards, compressors, pumps, potable water and sewerage treatment plants. It might be used as a shop for the repair of equipment. In this case it would contain welding machines, burning equipment, grinders, miscellaneous hand tools, drill presses, lathes and similar equipment. It could be used as a storage vessel and for several other uses that have not been mentioned. It essentially is a structure that floats on water with all these 'bits' on it.

In this particular case study, the barge was used as a means of exploiting a large number of small ore deposits found along a large tributary of a river. The plant would then be floated down the river from deposit to deposit. The point was to get the ore from the river bank, then use the plant on the barge to prepare the ore for transportation and transfer it to transporters (smaller barges) that would carry the ore to a metallurgical plant at the river mouth. This was the context. This narrative was what was given to the students as an introduction to the case study. Please refer to Appendix 2 (Page 161) for the actual task as it was given to the students.

This sort of introductory statement was given for most case studies depending on what they were. The specific outcomes of this case study were the following:

- General processing knowledge: Raw material handling
- Engineering practice: conceptual design, equipment selection, task management, elementary costing
- Technical concepts: mass/volume relationships, processing logic, flowsheets

The initial task required the students to determine if the barge would be able to float or not. To do that the students were expected to draw on their conceptual knowledge of density, buoyancy, Archimedes principle and force balances. They were expected to

realise that these were the salient aspects of the problem. The next task involved the sizing and selection of equipment based on given operating conditions. Operating conditions include the expected amount of river sand to be mined or the tonnage that needed to be delivered to the metallurgical plant at the other side of the river. Certain models were provided to students at different operability ranges to calculate the necessary variables. Students were expected to redesign the barge. The concepts involved here were bulk density versus normal density capacity and volume of equipment, as well as flowrate relationships.

Throughout all this the students were told that they had to think of themselves as belonging to a team of engineers involved in a project. The tasks were framed as such. This is part of what Duguid et al (1989) would call the peripheral features of authentic tasks. The students were also told that these types of tasks constitute what professional engineers do.

The second case study was a sugar processing plant. The specific point of this case study was to hone in on aspects of technical concepts particularly flowsheet development and processing logic. The rest of the case studies were along this line with different concepts e.g. density, pressure, temperature, concentration, and mass balances, added as appropriate. The interpretation of flowsheets was another skill that was dealt with quite extensively. Please refer to the Appendix 3 (page 181) for the actual task as it was given to the students.

Initially the mode of assessment was through portfolios. However that was quickly abandoned due to the varied nature of responses from students and the difficulty in trying to derive a formative grade from the submissions. After this, assessments assumed the usual format of long-answer-short-answer questions, with the occasional multiple choice questions added.

## **CHAPTER SIX**

### ***6. METHODOLOGY***

#### **6.1 Introduction**

The following section gives detail of the instruments and techniques used to collect and analyse the data. A detailed description of the sample is also given. An ideal task analysis is done for three tasks against which the structural complexity of the student responses to each of these tasks is compared. The student responses form the data and the instrument used to ascertain the structural complexity is the SOLO taxonomy.

#### **6.2 The SOLO Taxonomy**

The instrument used to measure the structural complexity of the student responses in this research is the SOLO taxonomy. To capture the levels of structural complexity Biggs and Collis (1982) developed the SOLO taxonomy. They assert that learning quality depends on extrinsic factors (such as the quality of the instruction) and intrinsic factors (such as student motivation, development stage and prior knowledge). For example if a student lacks motivation to learn, they generally do not pay attention to the lesson and if they have no prior knowledge, they resort to tautology to mask their ignorance. Further, some students tend to give responses that have traits that are typical of thinking at certain developmental stages. Piaget and colleagues have investigated these ways of thinking and have found that often they corresponded to certain levels of intellectual functioning. He used these ways of thinking to characterise stages in intellectual development from birth to childhood, hence stage theory. Biggs and Collis therefore derive their system from key conceptual insights from Piaget's theory.

Certain assumptions underlie the stages. The assumptions will not be detailed suffice it so say that Biggs and Collis argue against one particular assumption. This assumption is that once an individual arrives at a stage he thinks in a way that is characteristic of that stage and not of an earlier or later one. Biggs and others analysed student responses of students from elementary school through to college and found that while stages progressed from

simple to complex, student responses did not consistently reflect thinking typical of their stages from subject to subject and at different times.

To redress the problem they chose to shift the focus from the person or student to the response. They did not think it inconsistent if a student in one day in maths giving a response typical to a response that a formal operational student would give and on another day in history giving a response typical of students at the concrete operational stage. They then differentiated between the general cognitive structure of the individual and the structure of the response. The former they considered immeasurable and hypothetical and the latter they called the structure of the observed learning outcome (SOLO). They saw it as bearing the imprint of generalised central processing carried out by the individual. They maintain therefore that with regard to the intrinsic factors as determinants of learning quality, developmental stage only determines the upper limit of functioning and other factors including prior knowledge etc. determine whether one functions to that level or not.

The different SOLO levels typify the structure of the response in terms of a number of different parameters these being, capacity, relating operation and consistency and closure. Biggs and Collis posit five levels of response complexity i.e. prestructural, unistructural, multistructural, relational and extended abstract. These are elaborated on in due course. Capacity has to do with the amount of working memory available to do the problem. To give a good response the student would have to be able to pay attention and work with several parameters at once. Working memory is more than just remembering or thinking about several things at the same time. It involves thinking about and reflecting on previous experiences whether physical i.e. experience which is about having physical experience of something or logico-mathematical i.e. which is about experiencing the actions one performs on objects to modify the objects.

This is the point of departure for deductive reasoning. A good response would have to be the result of thinking about the sorts of actions that were previously performed on objects, the nature of those modifications and the resultant changes. Perhaps that is the reason that

some people think ‘like five year olds’ in one subject and ‘like twenty year olds’ in the next. They may not have necessarily experienced objects and performed actions on objects to the extent necessary to produce a rich response. That would require a person to simultaneously perform several mental tasks including reasoning and the working memory must allocate available cognitive resources.

The relating operation refers to the way in which the cue and the response interrelate. Consistency and closure refer to the felt need by the student on the one hand reach to a conclusion (closure) and on the other to achieve consistency between the conclusion and the data, and between the different conclusions. Poor responses are quick to reach a conclusion but as such do not achieve consistency. Good responses do not always reach a conclusion but are highly consistent and leave it to the reader to draw their own conclusions. The greater the need to reach a conclusion, the fewer data will be used. The effect of the three categories to each of the SOLO levels is depicted in table 1 below.

**Table 1: The SOLO Taxonomy**

SOLO Description	Capacity	Relating Operation	Consistency and Closure
Extended abstract	Maximal: cue + relevant data + interrelations + hypotheses	Deduction and induction. Can generalise to situations not experienced	Inconsistencies resolved. No felt need to give closed decisions – conclusions held open, or qualified to allow logically possible alternatives.
Relational	High: cue + relevant data + interrelations	Induction. Can generalise within given or experienced context using related aspects	No inconsistency within the given system, but since closure is unique so inconsistencies may occur when he goes outside the system.
Multistructural	Medium: cue + isolated relevant data	Can generalise only in terms of a few limited and independent aspects	Although has a feeling for consistency can be inconsistent because

			closes too soon on basis of isolated data and so can come to different conclusions with the same data.
Unistructural	Low: cue + one relevant datum	Can generalise only in terms of one aspect	No felt need for consistency, thus closes quickly, jumps to conclusions on one aspect, and so can be very inconsistent
Prestructural	Minimal: cue and response confused	Denial tautology, transduction, bound to specifics	No felt need for consistency. Closes without even seeing the problem.

Because the research interest is in learners' epistemic access to case studies, their responses to the tasks entailed in the case studies will be analysed.

### 6.3 The sample

In PRME1002, the entire class is divided into three major groups i.e. X, Y and Z. Within each of these major groups there are minor groups of three students each such that within X there is Xa, Xb, Xc etc., within Y there is Ya, Yb, Yc etc., and so on. The students were allocated to these groups in the first quarter of the year. The sample consists of three groups of three students each. The first group of three is from group X; the last two groups are from group Z. The students were selected according to their performance at the end of the first quarter as well as the groups in which they belonged. The first group consists of weak students where two out of the group of three achieved 49% and below at the end of the first quarter. The second group consists of intermediate performers where two of the three students achieved between 50 and 68%, and the third group consists of good students where two of the three achieved from 69% and above.

Of the nine students, eight are Black African students and the other student is a Chinese student. The sample consists of six females and three males. The students are labelled as student A, B, C up to student I.

### **Students A, B and C**

This subgroup belongs to group Z. Students A and C are black females while student B is a Chinese female. This is the highest achieving group where two of the three members achieved 69% and above. Student A achieved 60% and Students B and C achieved 76% and 69% respectively. Student A comes from an English medium school and achieved an A in Mathematics and a C in English. Student B comes from an English medium school. She achieved an overall aggregate of A in matric with A's in Mathematics and English, and received merit awards for academic achievement. Student C comes from a Tsonga medium school. She achieved an overall aggregate of A in Matric with an A in Mathematics and a B in English.

### **Students D, E and F**

This subgroup belongs to group Z. All three students are black females. This is the intermediate achieving group where two of the three members achieved between 50% and 68%. Student D achieved 62% and Students E and F achieved 50% and 40% respectively. Student D comes from Unisa and Edumap colleges which are both English medium institutions. There is no information about her matric symbols. Student E comes from an English medium school. She achieved an overall aggregate of A in matric with an A in Mathematics and a B in English, and received merit awards for academic achievement. Student F comes from a Zulu medium school. She achieved a C in Mathematics and a C in English.

### **Students G, H and I**

This subgroup belongs to group X. All three students are black males. This is the weakest group where two of the three members achieved below 49%. Student G achieved 59% and Students H and I both achieved 24%. Student G comes from an English medium institutions. He achieved an overall aggregate of B in matric with a B in mathematics and

an A in English. Student H was a student at the University of the Witwatersrand in a different faculty. He is considerably older than the rest of the first year class and has been an educator in secondary schools. Student I comes from an English medium school. He achieved an overall A aggregate in matric with A's in Mathematics and English.

## **6.4 Data collection and analysis**

### **6.4.1 Data**

In order to meet the research aims and to address the research questions, the manner in which the data was gathered is described below. Students' responses from the mid-year examination were used as data. The mid-year examination was in the format of a case study. A scenario was presented which formed the big context and from this five sub tasks formed the examination questions. Three of the five sub tasks were chosen for analysis. Of the three, the first question (question 1) was a descriptive question heavily reliant on the entire context presented; the last two were calculation questions. The first of the two calculation questions (question 2) was strongly reliant on context and the last (question 4) presented an abstract situation from the context. Questions 1 and 2 therefore required the students to take context features into consideration.

### **6.4.2 Task analysis**

The first sub question in this research was 'what do the students need to know and to do to successfully engage with the task and the course?' In order to establish this, an ideal task analysis was done on each of the three questions with the aim of establishing a clear and detailed description of the demands of the task. Each task analysis included the following:

- (1) A general list of what constitutes successful solving of the problem.
- (2) The context as should have been understood by the student.
- (3) The question to address.
- (4) A table with data including data given in the context as well as all data, including concepts, that the students needed to bring to bear on the problem. This was a function of what the problem required.
- (5) Data labels and necessary explanations.

- (6) Definition of all technical terms used.
- (7) The kind of thinking required.
- (8) A schematic diagram of the solution path to illustrate the structural complexity of the response and the connectedness of the different stages.
- (9) The solution path divided into the stages each labelled as a representation.
- (10) General final comments on the strategy.

The analysis was a rigorous effort aimed at addressing the first research question i.e. what do the students need to know and to do to successfully engage with the task and with the course generally? This analysis served as a framework against which the student responses were evaluated. It brought insight into several task related issues such as the different forms of 'knowing' appropriate for each aspect of content, as well as instances where students' orientations to knowledge become potential barriers to successful engagement with the tasks. The task analysis for each task was developed entirely by the researcher. The three ideal tasks are presented below.

#### **6.4.2.1 Ideal task analysis – the models**

The following are the three ideal task analyses, which include the SOLO response structure in diagram form. These two tasks were part of the mid-year exam that forms a proportion of the students' summative grade at the end of the year. Students' responses to this task and the next will be compared to the ideal tasks, and categorised in terms of structural complexity i.e. prestructural, unistructural, multistructural and relational. A successful response to the task requires the following:

- Examining all data provided
- Determining what is required or being asked for
- Having a strategy to move from what is given to what is being asked for by making relevant connections
- Knowing which concepts or principles will help relate the data appropriately
- Keeping track of each progressive step and bearing the question in mind at each step

- Making sure that there are no contradictions among data; that only relevant interrelations are made; that principles and concepts are not violated.

### The Context for all three questions

An environmental engineering company has developed a process for removing SO<sub>2</sub> from power station gases. It is a dry process in which the conventional scrubbing liquid is replaced by a solid absorbent phase and the gas scrubber is replaced by an absorption tower. In the absorption tower, the tiny particles of the absorbent mix with the gases in a conventional gas scrubber. Transportation of fine absorbent particles from units L, M and N to other units is done 'pneumatically' meaning that they are caught up in a gas stream and flow with that gas stream. (Some of the combustion gases – streams 11 and 12 – are used for such transportation). The absorbent phase is alkalisated alumina (Na<sub>2</sub>O.Al<sub>2</sub>O<sub>3</sub>). The chemical reactions used in the whole process are:

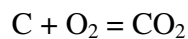
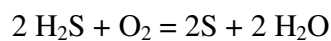
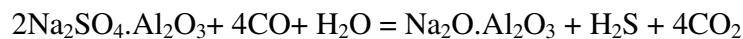
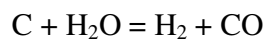
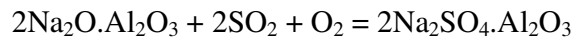

The developers claim that the process will remove 92% of the SO<sub>2</sub> from power station combustion gases. If this were achieved, what would the production rate of Sulphur be in kg/day?

The context also includes the mass balance table, the process flowsheet and the conversion information. See Appendix 1.

### The problem – Question 2

1. Calculate the production rate of Sulphur in kg/day.

The chemical reactions above, the process flowsheet and all the information, definitions, concepts and principles appearing in the data table below are all that is needed to complete this task and the next. However not all the data is applicable for both tasks. The students are expected to select and use only the information relevant to the task. None of the concepts/principles presented in Table 2 are presented to the students. They are expected to know which concepts/principles are relevant for each task. When the task was presented to the students, the information in Table 2 was not presented in table format nor was the data labelled. This has been done for ease of analysis.

In the data table and the response table, the following conventions are used:

D1.1 – D is for data, the first 1 is for level one, which represents any data that is given with the question, and the second 1 means the first piece of data.

D1.2 – This therefore refers to the second piece of level one data and D1.3, the third piece of level one data. This is all provided to the student before they start the question.

D2.1 – The D is for data, the 2 is for level 2 (derived or generated data) and the 1 means that it has been generated from the first interrelation. This refers to any data that the student has generated from interrelations among level 1 data and concepts.

C1 – This refers to ‘concept’. 1 means that it is the first concept. These are any concepts or principles that are needed to make the relevant connections among the data (level 1 and level 2).

R.1 – This refers to data representation. It is a way of demonstrating the relationships among the different concepts. In general, concepts and principles are represented by equations. The variables in those equations are the data, in this case both level 1 (original) or level 2 (generated). The 1 in R.1 refers to the first representation and 2 to the second and so on. The representations therefore link the data and the concepts to generate new data. Some representations are derived from chemical engineering. Therefore, the ideas conveyed by that representation would not make sense mathematically. Others are mathematical representations of engineering concepts. You could therefore explain the logic of that representation mathematically. Use of incorrect or irrelevant data in a representation, such that a concept or principle is violated, automatically invalidates that interrelation.

**Table 2: DATA TABLE**

Given Data		Concepts and type of knowledge	
D1.1	The chemical reactions. See list above.	C1	$\frac{n_{react}}{n_{in}} = 0.92$
D1.2	The gas constant i.e. R = 0.08206L.atm/(mol.K)	C2	$n_a = \frac{\text{mass of a}}{\text{molecular weight of a}}$
D1.3	Mass balance table particularly:	C3	Mole percent, $a \frac{\text{moles} \cdot \text{of} \cdot a}{\text{moles} \cdot \text{of} \cdot \text{mixture}}$ . This is true also for mass percent.
	D1.31 $V_7$ – volumetric flowrate of gas stream	C4	PV = nRT, where P,V and T are as per D1.3, R is as per D1.2 and n is the total number of moles of the gas stream.
	D1.32 $T_7$ – temperature of gas stream		
	D1.33 $P_7$ – pressure of gas stream		
	D1.34 mole percent of SO <sub>2</sub> in gas stream	C5	If $aA + bB = cC$ , then a moles of A react with b moles of B to produce c moles of C.
D1.4	Process flowsheet	C6	A mass basis of 100kg of mixture (this can be anything, 100 easy to work with).
D1.5	Conversion info i.e. 1m = 3.2808ft, 1 lb <sub>m</sub> = 0.4536kg, 1 ton = 1000kg, 1m <sup>3</sup> = 1000L	C7	$\frac{\text{density} \cdot \text{of} \cdot a}{\text{density} \cdot \text{of} \cdot \text{water}} = SG_a$
D1.6	Atomic masses i.e. Al – 27, Na – 23, C – 12, H – 1, N – 14, O – 16 and S – 32.	C8	$\frac{\text{density} \cdot \text{of} \cdot \text{mixture}}{\text{density} \cdot \text{of} \cdot \text{water}} = SG_{\text{mixture}}$
D1.7	SG of Na <sub>2</sub> O = 2.27	C9	Volume or mass basis of mixture, 1m <sup>3</sup> or 1000kg easiest to work with
D1.8	SG of Al <sub>2</sub> O <sub>3</sub> = 3.40	C10	Tot mass = mass A + mass B, where mass A = density of A x volume of A. The same applies to B.
D1.9	SG of mixture = 3.09	C11	Density of mixture is $\frac{\text{mass} \cdot \text{of} \cdot \text{mixture}}{\text{volume} \cdot \text{of} \cdot \text{mixture}}$
D1.10	Conversion percent = 0.92		

**RESPONSE TABLE**

The following is an ideal task analysis of question 2. This is what the students are expected to produce.

This is a situated task. A context is set up such that it provides all the resources necessary to address the problem. For ease of analysis, I have gathered both the given data and the concepts that the students should have in terms of prior knowledge without which the task will not be solvable. The reasoning processes that generate the different representations are given below. The table appearing after the explanation is a consolidation with the appropriate data labels. The terms 'quantity' and 'amount' refer to the engineering term 'mole'. A mole is an expression used for quantity and is different from but related to mass and volume.

**The ideal chain of reasoning is presented below.**

- R.1** From the reactions given, sulphur is produced step by step in the reaction of the gas  $\text{SO}_2$  to the absorbent, reaction 1 through to reaction 5. What are required are the amounts of the gas and the absorbent. Only one of these is needed, the other will then be determined from the stoichiometry. Stoichiometry is a quantity relationship between the reactants and the products. Nothing is given about the absorbent but quite a bit of information is given about the gas  $\text{SO}_2$ . Now the gas  $\text{SO}_2$ , the reactant gas, is really part of a larger feed gas stream that contains other gases. In order to find out the amount of the reactant gas, we need to know the amount of the entire feed gas stream as well as what portion of this amount is just the  $\text{SO}_2$ . This latter amount is what is available to react with the absorbent. We are given the following properties of the entire feed gas stream i.e. its volumetric flowrate, its temperature, its pressure, and the gas constant. These are D1.31, D1.32, D1.33 and D1.2 respectively on the table. Now there is a representation that combines all these different gas properties to give the amount of the feed gas. This appears as C4 on the table. This value is the first piece of data generated which is D2.1. (This representation is a chemical engineering representation which was derived from experiments that posited a proportionality relationship between the amount of gas and the gas temperature, pressure and volume.)
- R.2** Now that the amount of the entire feed gas stream is known, the portion of that amount that is just the reactant gas  $\text{SO}_2$  is calculated next. The appropriate

representation for this is shown in C3. The percent of  $\text{SO}_2$  in the total gas stream is given by the amount of the  $\text{SO}_2$  divided by the amount of the total gas stream. We are given the percent of the  $\text{SO}_2$  therefore the amount of the  $\text{SO}_2$  will be given by the total amount of gas multiplied by the percentage of gas. This representation makes use of engineering concepts in a relation that makes sense mathematically. This value is D2.2 and is the total amount of  $\text{SO}_2$  that is available to react.

**R.3** We are told that ‘the process will remove 92% of the  $\text{SO}_2$  from the power station combustion gases’. This is the first instance of data interpretation to translate this statement into a representation. Since we have established from the reactions given and from the original problem statement, that the gas  $\text{SO}_2$  is the gas to be removed, from this phrase we can say that a) it is removed from the entire feed gas stream mentioned in **R.1** and **R.2**, and b) that only 92% of the  $\text{SO}_2$  in the entire feed gas reacts with the absorbent. What is required here is a representation that relates the amount of  $\text{SO}_2$  that has reacted,  $n_{\text{react}}$ , with the amount of  $\text{SO}_2$  actually present in the feed gas,  $n_{\text{feed}}$ . This is down as C1 on the table. This gives the amount of  $\text{SO}_2$  that reacts, D2.3, from what is available to react, D2.2.

**R.4** From the above we have the amount of  $\text{SO}_2$  involved in reaction 1. According to stoichiometry (the quantity relationship between reactants and products) 2 amounts of  $\text{SO}_2$  react with 2 amounts of absorbent to produce 2 amounts of loaded absorbent. Loaded absorbent is absorbent that has incorporated in its structure the  $\text{SO}_2$  gas. The loaded absorbent is then involved in reaction 3 and 4 where 2 amounts of  $\text{H}_2\text{S}$  are produced. This then produces in reaction 5, 2 amounts of Sulphur. Combined therefore, the reactions produce 2 amounts of Sulphur from 2 amounts  $\text{SO}_2$ . In other words, the amount of  $\text{SO}_2$  that was calculated in **R.3**, the rate at which the  $\text{SO}_2$  reacts is equal to the rate at which Sulphur is produced. This is D2.4.

**R.5** All that happens now is that D2.4 is converted into the right units of measurement. In D2.4 the value is in moles per second. It needs to be converted to mass (kg or ton) per day. It is accepted practice within chemical engineering that production rates are expressed on a kg (or ton) per day basis. Otherwise the numbers become too large. To convert mole per second to tons per day is a two step process. First the moles are converted to kg (or tons which are 1000 times greater). This happens through the representation given as C2 on the table. This is a chemical engineering representation. To convert seconds to days requires a simple representation that is not specific to chemical engineering. The answer is then given as kg/day or tons/day.

### COMMENTS

This problem therefore has five distinct stages. After each stage, a piece of information needs to be used to change the course of the solution path. These data link the stages such that a structure is produced. See the structure below. It is linear but this does not imply that it is a simple structure.

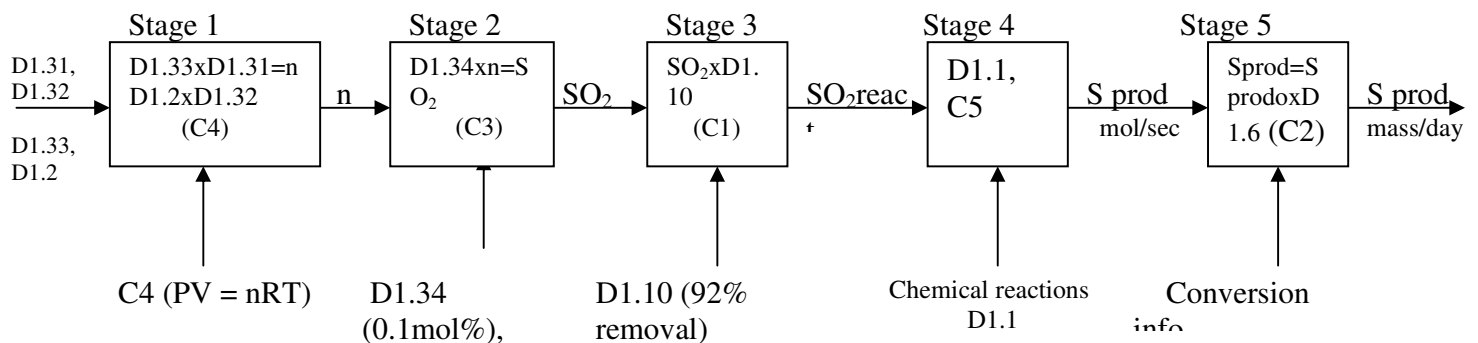

Each block represents a stage where inputs are transformed to outputs. The transformation at each stage uses different representations,  $C_i$  (where  $i$  is any number) which in the stages appears in parenthesis. None of the  $C_i$ 's are given. The students are expected to know them and to use them appropriately.

**STAGE 1** The raw data i.e. D1.31 to D1.33 and D1.2 is transformed to  $n$ , the number of moles of the total gas feed stream of which  $\text{SO}_2$  is part. The

representation that facilitates this transformation is C4 ( $PV = nRT$ ). This is not given. The students are expected to know it and to know that it needs to be used at this stage. It is the only appropriate way in which the data given can be transformed to  $n$ .

**STAGE 2** This stage transforms the  $n$  to  $SO_2$ , the amount of  $SO_2$  present in the feed gas. The transformation happens through new data in the way of D1.34 (0.2mol%  $SO_2$  in feed gas) through the representation C3.

**STAGE 3** This stage transforms the amount of  $SO_2$  in the feed gas to,  $SO_{2reacts}$ , the amount that actually reacts or is removed by reaction. To do this the appropriate representation combines new data, D1.10 (the percent removed by reaction) through the representation C1.

**STAGE 4** This stage transforms the  $SO_{2reacts}$  to  $S_{prod}$  in the units of moles per second, the amount of sulphur produced through new data D1.1 (the chemical reactions) and representation C5.

**STAGE 5** The final stage transforms the  $S_{prod}$  to new units (mass per day) using data D1.5 and D1.6 in the representation C2.

At the end of each stage, the student would need to pause and ask themselves some questions, which would lead to them to return to the problem statement to see if there is anything that would need to be added at that point. For example, during the first stage, C4 is used to work out the flowrate of the feed flue gas. The question after this stage would have to be, what proportion of this is  $SO_2$ ? This would force the student to either recall the details of the question or at least to go back and read for possible extra information.

The new piece of information would then be used to work the proportion of the flue gas that is  $SO_2$ , which is stage 2. The next question would be; does all this  $SO_2$  react? This question would then force the student to recall or go back to the problem statement to see

that only 92% of the SO<sub>2</sub> is removed. This is stage 3. The student would have to ask; how much sulphur does the SO<sub>2</sub> reacted actually produce? This would lead them to look at the reactions 1 to 5, and to use stoichimetry to figure this out. This is stage 4. Once this is done, the student would have to recall the required units or check from the question and realise that a conversion from moles per second to mass per day is required. The table below shows the sequence of calculations.

**Table 3: Response Table**

<b>Representations</b>	<b>Comments</b>
<b>R.1</b> is $\frac{D1.31 \times D1.33}{D1.2 \times D1.32} = D2.1$	Since the production of Sulphur starts with the reaction of absorbent with SO <sub>2</sub> , we need moles of SO <sub>2</sub> that actually react, i.e. n <sub>react</sub> in C1. To get n <sub>react</sub> though is needed n <sub>in</sub> , SO <sub>2</sub> in the gas stream. To start use C4 and related data in D1.3 and find n, D2.1
D2.1	1.44 x 10 <sup>6</sup> kmol/day
<b>R.2</b> is $D1.34 \times D2.1 = D2.2$	D1.34 and D2.1 used in C3 will give moles of SO <sub>2</sub> in the feed gas. This yields D2.2
D2.2	120.2kmol/h SO <sub>2</sub> in feed gas
<b>R.3</b> is $D2.2 \times 0.92 = D2.3$	Only a portion of D2.2 reacts in reaction 1. That portion is 92%. To find how much this portion is in mole use C1. This yields D2.3.
D2.3	110.584kmol/h
<b>R.4</b> is $D2.3 = D2.4$	This now needs to be related to the moles of S produced. This is done according to C5 with the reactions listed in D1.1. This shows that 2 moles of SO <sub>2</sub> react to produce 2 moles of S after four reactions. This yields D2.4.
<b>R.5</b> is $D2.4 \times 32 \times 24 \times \frac{1}{1000} = D2.5$	This needs to be converted to mass per day, which is the CUE, done as per C2. The denominator of C2 from D1.6 is 32. This yields D2.5, the solution. The 24 converts hours to days and the 1/1000 converts kg to tons, as per D1.5.
<b>Solution = D2.5</b>	<b>84.9 tons S per day produced.</b>

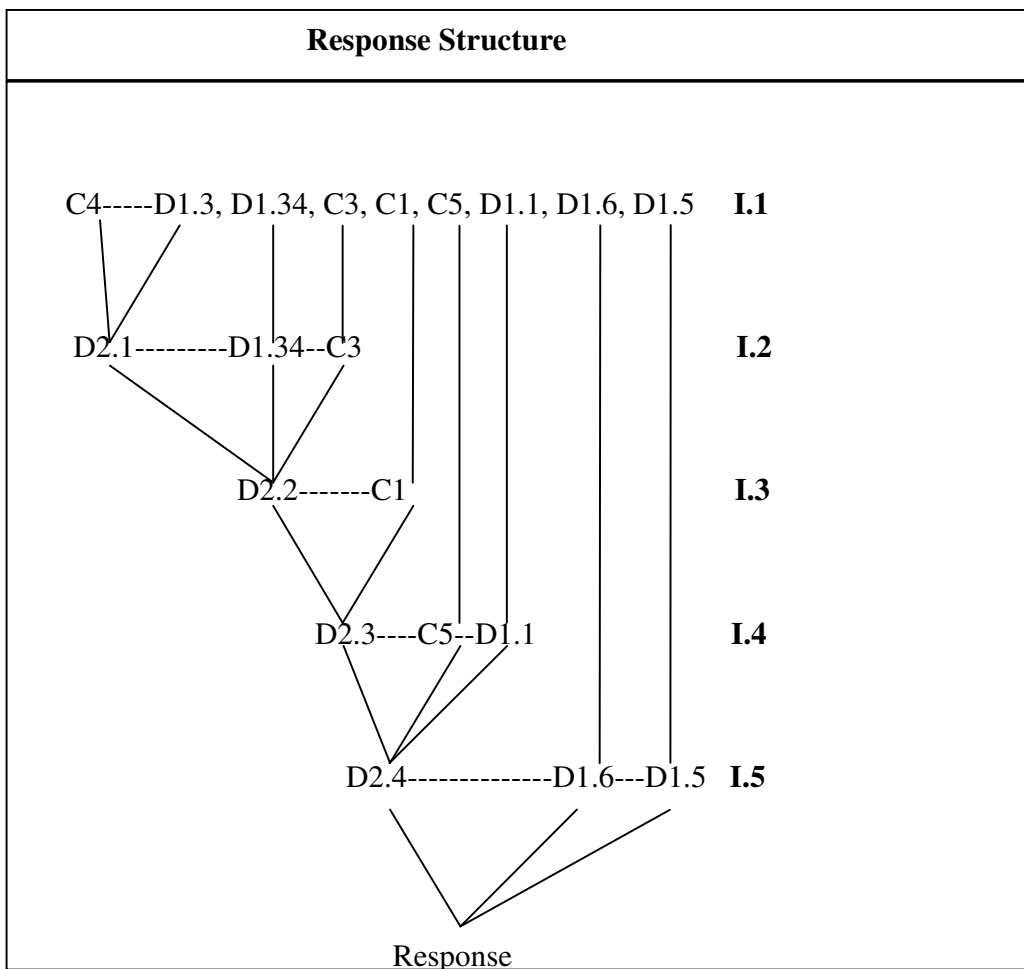

**The problem – Question 4.** (Use the same data table as for the previous question)

1. Assuming that each particle of absorbent is a mixture of solid  $\text{Na}_2\text{O}$  (SG 2.27) and solid  $\text{Al}_2\text{O}_3$  (SG 3.40), and that the mixture has an SG of 3.09, what is the mass percent of  $\text{Na}_2\text{O}$  in the mixture?

**RESPONSE TABLE**

The following is an ideal task analysis for question 4. This is what the students are expected to produce.

This task is an example of moving from the situated to the abstract. Unlike in the previous questions, the students cannot look to any part of the context for help in

generating a solution. Even if the context is not there, the problem is still solvable. The only link this task has with the context is that a hypothetical situation has been set up where the absorbent that reacts with the offending  $\text{SO}_2$  has certain characteristics and the student is asked to do a calculation under those hypothetical conditions. This means that a magnifying glass has been focussed on one aspect in the bigger task and the students have to think abstractly.

**The ideal chain of reasoning is presented below.**

- R.1** We are given a mixture which consists of  $\text{Na}_2\text{O}_3$  (Na) and  $\text{Al}_2\text{O}_3$  (Al). We are also given the specific gravities. These need to be converted to densities. Specific gravity (SG) is a value that expresses the relationship between the density of a substance and the density of water. Therefore, the density of a substance divided by the density of water (which is standard at  $1000\text{kg/m}^3$ ) gives the specific gravity of the substance. This is shown as C7 and C8 on the table. Therefore, all three of the SGs given need to be multiplied by 1000 to give the densities of the mixture, Na and Al, which are D2.1, D2.11 and D2.12 respectively.
- R.2** Next, because we are asked to calculate the percent of Na in the mixture, we need a basis on which to base the calculation. In other words, an amount of mixture is needed, either its volume or its mass. This is an assumed value; it can be anything. Often  $1\text{m}^3$  or  $1\text{kg}$  of mixture are easier to work with. To avoid fractions, it's best to choose a volume basis of  $1\text{m}^3$ . Now this basis means we now have two pieces of information about the mixture, its density, 3090, and its volume,  $1\text{m}^3$ . These two can be related by a representation as given in C11. This means that multiplying the given density of the mixture by the assumed volume basis gives the mass of the mixture. This is D2.2.
- R.3** According to the law of conservation of mass, the mass of the mixture, D2.2 above, so equal to the mass of Na and Al. but the masses of Na and Al are not directly available. But in the same way that we related the density of the mixture to the volume and got the mass of the mixture in R.2 above, the same thing

applies here. Therefore, the mass of Na will be the density of Na, D2.11, multiplied by the volume of Na. Likewise the mass of Al is the density of Al, D2.12, multiplied by the volume of Al. The individual volumes of Na and Al are also not available. However, we can say that the total volume of the system, which we assumed to be  $1\text{m}^3$ , is the sum of the two volumes of Na and Al. Therefore, instead of writing the mass of Al as its density multiplied by its volume, we can write its volume as the difference between the total volume i.e.  $1\text{m}^3$  minus the volume of Na. In the end the left hand side of the total equation is 3090 (the mass of the mixture) and the right hand side of the equation has only one unknown, the volume of Na. This is D2.3.

**R.4** The volume of Na is now available. Its mass must be calculated next. Again, we relate the volume to its density to get its mass. This new volume is multiplied by D2.11, the density of the Na, to get the mass. This is D2.4.

**R.5** The mass percent of Na in the mixture is given by the representation in C3. The mass D2.4 is divided by the mass of the mixture, which in R.3 was D2.2. This quotient is multiplied by 100 to give the percentage of Na in the mixture.

## COMMENTS

Unlike the previous problem, this one does not have distinct stages. It has a structure, but due to the non-linearity with regard to solution path, the structure is complex. See the structure below.

B7

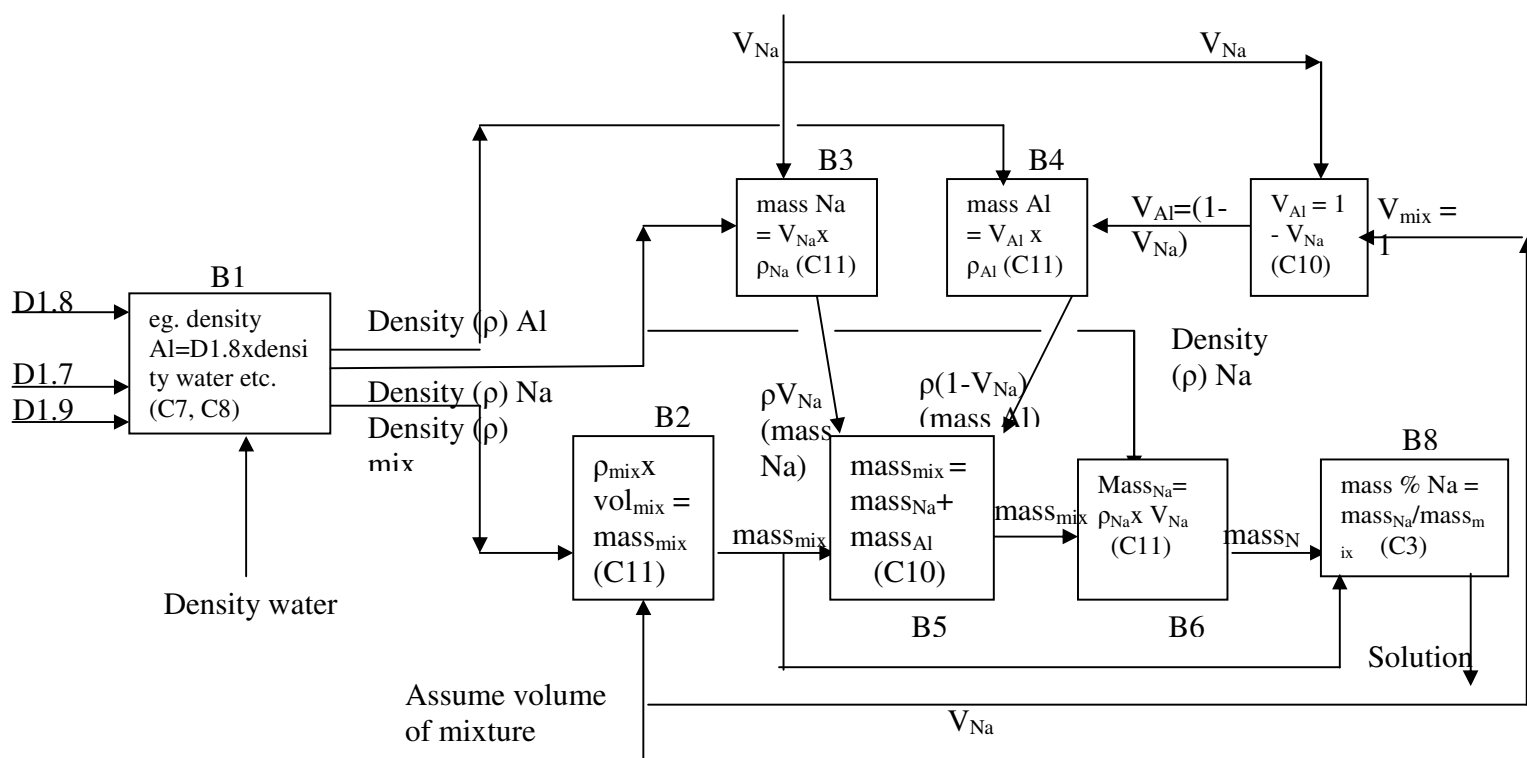

Each block represents a transformation of inputs to outputs. The transformations use different representations,  $C_i$  (where  $i$  is any number) which appear in parenthesis. None of the  $C_i$ 's are given. The students are expected to know them and to use them appropriately.

- B1** There is no definite starting point. One could start with B1 as per example.  $C_7$  and  $C_8$  transform the raw data i.e. D1.7 to D1.9 into densities (output of B1) using the density of water.  $C_7$  and  $C_8$  are not given. The students are expected to know this and use it appropriately.
- B2** each of the outputs from B1 go to different places. The density of the mixture is used in B2 with the volume basis and is transformed to the mass of the mixture.
- B3** The density of Na (second output from B1) is transformed to a mass using its volume. The representation is  $C_{10}$ . The output from this process is not just mass

- of Na but rather  $\rho_{\text{Na}} \times V_{\text{Na}}$  (its equivalent). This makes this output more useful for B5.
- B4** This does the same transformation as in B5 but on Al. Notice that instead of mass of Al (the output) being written as  $\rho_{\text{Al}} \times V_{\text{Al}}$ , the  $V_{\text{Al}}$  is replaced with  $(1 - V_{\text{Na}})$ . The latter is the output from B7. This makes it more useful for B5.
- B5** This block transforms the mass of the mixture and the individual masses of Na and Al into the volume of Na. For this to happen, the inputs, in terms of the individual masses, have to be in a form that facilitates the transformation i.e.  $\rho_{\text{Na}} \times V_{\text{Na}}$  and  $\rho_{\text{Al}} \times (1 - V_{\text{Na}})$ . The output of this is volume of Na.
- B6** The volume of Na is transformed to mass of Na by using the density of Na (output of B1). The representation that facilitates the transformation is C11.
- B7** This block transforms the volume of Al to volume in terms of the basis  $\text{m}^3$  and  $V_{\text{Na}}$ .
- B8** The mass of Na from B6 is transformed to a mass percent of Na by using the output from B2 in a representation C3. This is the solution.

One could also start at B2 with the assumption and then work back to get the density needed in B2 through the representation C11. What is crucial here is the assumption of a basis for the mixture. If a basis is not chosen, the problem cannot be solved. This example has used a volume basis. This sets the mass of the mixture because the density of the mixture is known. A mass basis would lead to the same answer, have the same structure but the outputs and inputs would be configured differently. For example, the blocks predominantly have mass. If a mass basis were chosen, the blocks would have volume predominantly. Secondly, instead of multiplying a density by a volume to get a mass, one would have to divide a mass by a density to get a volume. Therefore, this task plays with

relationships between density, mass and volume, as well as the relationship between a mixture and its components in terms of mass, density and volume.

The other crucial thing is to realise that the mass of the mixture is the sum of the individual masses of Na and Al. The individual masses would have to be rewritten in terms of density of each of Na and Al (which would have been worked out) and volume of each. The volume of each can be related to the volume basis chosen. To be able to do this, the student would have to recognise that the total volume (i.e. the basis of  $1\text{m}^3$ ) is the sum of the volume of Na and Al. This happens around B3, B4 and B7. The volume of Al could then be re-written in terms of  $1\text{m}^3$  and the volume of Na (or vice versa) i.e.  $V_{\text{Al}} = 1(\text{m}^3) - V_{\text{Na}}$ . This means that the only unknown is  $V_{\text{Na}}$ . After this, the density of Na is used with this new volume to get the mass of Na. This mass is divided by the derived mass of the mixture to get the percentage of Na in the mixture. This is the solution. The table below shows the sequence of calculations.

#### **6.4.3 Data Analysis**

The data was analysed for structural complexity using the above task analysis as a basis. The students' responses were therefore categorised as either prestructural, unistructural, multistructural or relational. This depended largely on the extent to which the student examined and used all data provided; that they were clear on what was required; that they had a strategy to move from what was given to what was being asked for; that they deployed only the relevant concepts and principles and made the correct transformations; and finally that there were no contradictions in the solution and that no principles were violated.

#### **The Problem – Question 1**

Explain the function of each unit operation shown in the flow sheet and indicate which chemical reaction, if any, occurs in that unit.

**The ideal chain of reasoning is presented below**

**The boiler**

Observed (what the flow sheet shows). The students will not be given credit for stating these.

- Entry streams i.e. water, oil and air
- Exit streams i.e. steam, ash and stream no. 6.

Prior knowledge (includes knowledge the student has about the topic from another course or from a part of the current flowsheet that informs what they are doing)

- Boilers in general boil water to produce steam.
- For any boiling process to happen, energy input is necessary.
- Fuel contains chemical energy which when the fuel is burned changes to heat energy.
- Combustion reactions release energy
- Ash is a by-product of combustion reactions. It is the impurities consisting of silica, iron, alumina, and other non-combustible matter that are contained in coal.

Given data

- Chemical reaction number 6, with C representing the oil.

Conclusion

Steam is being generated by the combustion of fuel in this case coal. Water is fed into the boiler and the energy released from the combustion of the coal converts the water to steam. The reaction here is as follows:  $C + O_2 \rightarrow CO_2, H_2O + \text{energy}$  (above reaction is exothermic)  $\rightarrow$  Steam. Other products from this process are ash and the flue gas that proceeds to the dust extractor.

### **The dust extractor**

Observed

- Entry streams i.e. stream number 6 (flue gas)
- Exit streams i.e. stream no. 7(flue gas) and dust.

Prior knowledge

- Dust extractors remove dust from a gas stream.

Given data

- As per mass balance table, stream 7 is dust free.

Conclusion

The exit flue gas from the boiler contains dust which is removed in this unit. No reaction occurs here.

**The heat exchangers**

- All either add or remove heat from a stream. Look at the temperatures before and after the unit to tell whether it adds or removes heat to the stream.

**The Absorber**

Observed

- Entry streams i.e. contaminated cooled flue gas; stream 17 (recycled lean absorbent).
- Exit streams i.e. sweet (uncontaminated) flue gas, loaded absorbent

Prior knowledge

- Absorbers are towers used to remove offending components from gas streams
- In some cases liquids are used to absorb the offending components from the gas.
- The gas comes out cleaner or free from the offending gas component after the contact with the liquid.

Given data

- The absorbent is in fact a solid this time
- The offending gas is the SO<sub>2</sub>.
- Some of the gas that exits the dust extractor is used for transportation purposes
- The cleaner exit gas contains solid absorbent particles
- Stream 17 entering the top of the absorber contains solid absorbent

- Reaction 1.

### Conclusion

Most of the exit gas from the dust extractor proceeds to the absorber, where the  $\text{SO}_2$  associated with the gas is absorbed by the tiny particles of absorbent known as alkalis alumina ( $\text{Na}_2\text{O} \cdot \text{Al}_2\text{O}_3$ ). The reaction that occurs here is reaction 1. When the absorbent and the offending gas come into contact, they combine to form a new species i.e.  $\text{Na}_2\text{SO}_4 \cdot \text{Al}_2\text{O}_3$ . This is now known as loaded absorbent. The gas depleted of  $\text{SO}_2$ , not entirely of course as the process only removes 92% of the  $\text{SO}_2$ , leaves at the top of the tower to unit M. Recycled absorbent comes in via stream 17 to start removing more  $\text{SO}_2$  from the incoming stream 10. The absorbent that has collected the offending gas leaves at the bottom of the tower and joins stream 11 to become stream 13.

### Unit M

#### Observed

- Entry streams i.e. stream 16 (cleaned gas).
- Exit streams i.e. stream 27, cleaned gas and stream 14

#### Prior knowledge

- If a two phase stream enters a unit and the products from that unit are two different phases, that unit is a separator.

#### Given data

- Contents of streams 16, 27 and 14.
- Stream 16 has absorbent, stream 14 has absorbent and stream 27 has virtually none.

### Conclusion

This might be a separation device, possibly a cyclone, where whatever absorbent is entrained with the rising gas stream, stream 16, is trapped and redirected to stream 14. There is possibly further reaction 1 happening here due to the contact between the

offending gas stream and absorbent particles. Stream 27 has therefore very little  $\text{SO}_2$  while stream 14 has absorbent present due to the separation in unit M.

## Unit N

### Observed

- Entry streams i.e. stream 15 (loaded absorbent), stream 19
- Exit streams i.e. stream 20 (stripped or lean absorbent), stream 18

### Prior knowledge

- Most absorbers work in conjunction with what is known as a stripper.
- The stripper removes the offending gas associated with the absorbent and essentially 'frees' or restores the original absorbent in the form  $\text{Na}_2\text{O} \cdot \text{Al}_2\text{O}_3$  to go back to the absorber to collect more offending gas.

### Given data

- The reactions 3 and 4; both have the loaded absorbent in the form  $\text{Na}_2\text{SO}_4 \cdot \text{Al}_2\text{O}_3$  that is changed back to the form  $\text{Na}_2\text{O} \cdot \text{Al}_2\text{O}_3$ .
- Stream 19, which must contain  $\text{H}_2$  and  $\text{CO}$  and  $\text{H}_2\text{O}$ , otherwise reactions 3 and 4 cannot happen.

### Conclusion

The loaded absorbent is transported by part of the gas stream to unit N. Possibly some absorption is happening here. In Unit N, hydrogen, water and carbon monoxide from stream 19 are used to regenerate the absorbent which leaves as stream 20. It is carried by the gas in stream 12 and becomes stream 17 to enter the absorber. The reactions here then are reactions 3 and 4. This means that the associated Sulphur that was on the absorbent from reaction 1 is converted to  $\text{H}_2\text{S}$  and leaves the unit. Some absorbent is lost here since the mass balance table shows trace amounts of it in stream 18 and the flowsheet shows a make up stream, stream 21.

## Unit P

#### Observed

- Entry streams i.e. stream 18, stream 24
- Exit streams i.e. stream 22, stream 23

#### Prior knowledge

- Since the overall objective of this process is to generate less harmful S from more harmful SO<sub>2</sub>, this unit has to be somehow generating S from the reaction products of reactions 3 and 4.

#### Given data

- Reaction 5 whose reactants are products of reactions 3 and 4 minus the Na<sub>2</sub>O.Al<sub>2</sub>O<sub>3</sub>
- Stream 24 has to be air if reaction 5 is to happen.
- Stream 23 is sulphur.

#### Conclusion

This unit converts the H<sub>2</sub>S from reactions 3 and 4 which took place in Unit N, to Sulphur. The H<sub>2</sub>S reacts with air as per reaction 5 to produce S and water vapour. Some trace amounts of absorbent are lost here hence the need for a make-up stream.

### **Unit Q**

#### Observed

- Entry streams i.e. stream 25, stream 26
- Exit streams i.e. stream 19

#### Prior knowledge

- For reactions 3 and 4 to happen in Unit N, H<sub>2</sub> and CO are required.

#### Given data

- Stream 26 is 100% water.
- Stream 25 is coal
- Reaction 2

## Conclusion

The hydrogen and the carbon monoxide needed to regenerate the absorbent are formed from the reaction of coal with water, reaction 2. Sometimes this reaction produces carbon dioxide as well. There is also water associated with this stream.

## CHAPTER SEVEN

### *7. ANALYSIS AND DISCUSSION*

#### **7.1 Introduction**

Three questions are presented for analysis and discussion. Question 2 and question 4 are calculation questions and question 1 is an interpretation question. Questions 2 and 4 are handled similarly as described below. All three questions are analysed first followed by the discussion. For question 1, students' responses are not presented in diagram form. More detail is given at the start of the section that deals with question 1. For the problem statements and the indication of the context, please refer to chapter six in the task analysis. Question 2 will be dealt with first followed by question 4 and lastly question 1.

#### **Conventions used:**

The student responses are presented in diagram form to make the structure and deviations from the ideal form immediately discernible. The student responses are also superimposed on the ideal solution path. Normal lines indicate the ideal path. In places where the solution path of the student deviates from the ideal path, this is indicated in thick bold dotted lines. Therefore, all dotted lines represent invented or irrelevant data. All dotted boxes represent invalid or unknown representations. Proper data that has been incorrectly used is indicated as a dotted line that branches off from the ideal line. The structures are discussed under the two general headings of context and transfer. The former is sub divided into physical context, subtask and student's prior knowledge.

The structure of the ideal solution path captures the combination of form and content. Form is about the order of the transformations and the use of appropriate content in the appropriate stages. This creates the structure. If a stage is compromised by incorrect data or incorrect representations all consequent generated data is incorrect. Question 2 is a series of steps where inputs are transformed to outputs using appropriate representations. The data given in the context is transformed to other data using the representations and the information from the task. The horizontal lines indicate generated content and the vertical lines indicate information from the context or inferred data. If a student tries to effect a transformation and uses the appropriate representation but at the wrong stage, the

solution is compromised. A good response therefore arranges the content in a structure or form that demonstrates logic and an understanding of the entire question. It is possible to have proper form i.e. a linear structure that attempts to follow the logic, with improper content. This could happen if incorrect data or information has been used for a stage; if data has been omitted or if a student attempts to effect a transformation using inappropriate representations. Representations are the equations. For example, to transform a volume of a substance to its mass, one uses  $\frac{m}{v} = \rho$ , where the  $\rho$  represents the density of that substance. This transformation happens in the blocks.

The diagrams that follow represent the structure of the students' responses in relation to the ideal structure of the task. It focuses on the appropriateness of the student solutions in terms of form and content. In the diagram the following conventions are used:

- The normal lines represent the ideal solution path.
- Solid bold lines superimposed on the ideal path indicate that the student's solution follows the ideal form for that portion.
- Thick bold dotted lines indicate that the solution path of the student deviates from the ideal path. All dotted lines indicate invented or irrelevant data.
- Dotted boxes indicate inappropriate or invalid representations. This invalidates the transformations.
- A dotted line that branches off from the ideal line indicates appropriate data that has been incorrectly used. This compromises the form or structure of the response.

### **Response Categorisation**

**Relational** – A relational response is sound in terms of both form and content. All relevant content has been used. If there is an error it is minor i.e. copying down values incorrectly. The response is still classified as relational.

**Multistructural** – This response is sound in form but has one content error i.e. data omitted. However, a response will only be multistructural (despite the content error) if the transformations and representations that come before and after the error stage are appropriate, and are in the right order in terms of logic. This is also valid despite the fact that the content generated in subsequent stages will be incorrect due to the error.

**Unistructural** – This is problematic in both form and content. The content error here is not minor i.e. incorrect use of data and data omission where the subsequent stages do not follow the appropriate logic. The form is also compromised. This error may be generated by the inappropriate use of correct data or the combination of this with data omission. Both these conditions compromise the form.

**Prestructural** – This response uses at most one piece of given data. Combined with this might be the invention of data or incorrect use of data. This content error is major. It goes without saying that the transformations effected will not be valid and the form will be compromised. If the student does use more than one piece of data but inappropriately and introduces unknown or invented representations, the response is prestructural.

The difference between the unistructural and the prestructural responses is that in the latter, data and/or representations have been invented. The transformations where these representations are used are marked as ‘unknown representation’.

After the responses have been analysed structurally, the implications of this are discussed under the two general headings of context and transfer. The former is subdivided into physical context, subtask and student’s prior knowledge.

**Content:** All data has been used appropriately. A content error may compromise the form of the response. If a content error is minor, the form may not be compromised. If a content error is severe, form will be compromised.

**Form:** The appropriate transformations have been done using appropriate representations in a logical order. Content here may not be correct due to prior minor errors.

## 7.2 Results - Question 2

### 7.2.1 Student A

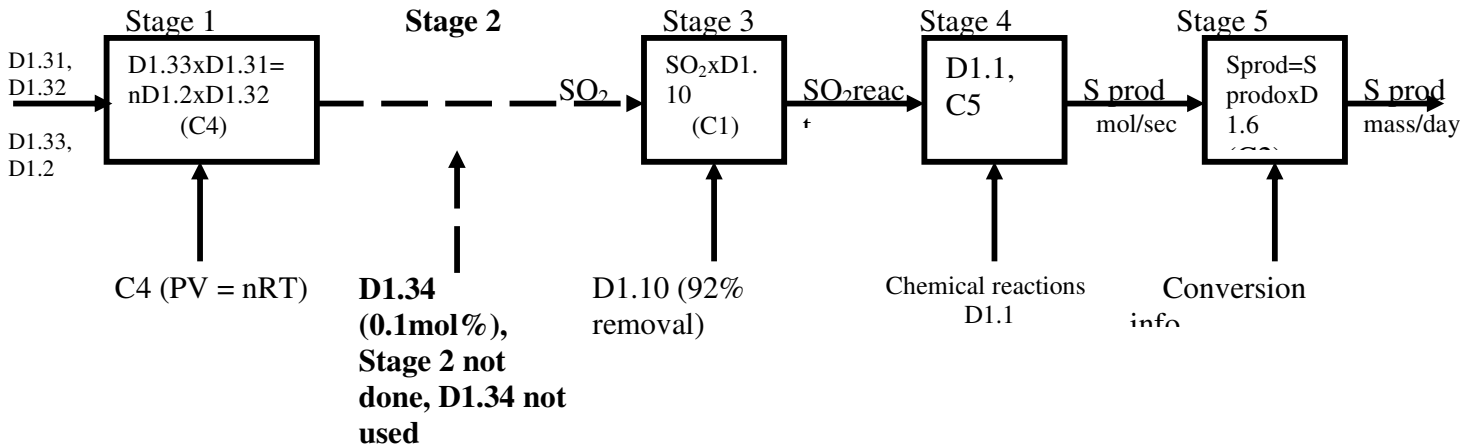

Student A misses out on the second piece of data for the second stage. This is a content error. Therefore, stage 3 is fed incorrect content or input. In stage 3 she transforms incorrect input and thus she generates incorrect content. This is despite making appropriate transformations using appropriate representations and data. Her form is sound; she uses all other data (except D1.34, which is content for stage two) and effects the appropriate transformations in the right order. She does not violate any principles. This response is therefore multistructural.

### 7.2.2 Student B

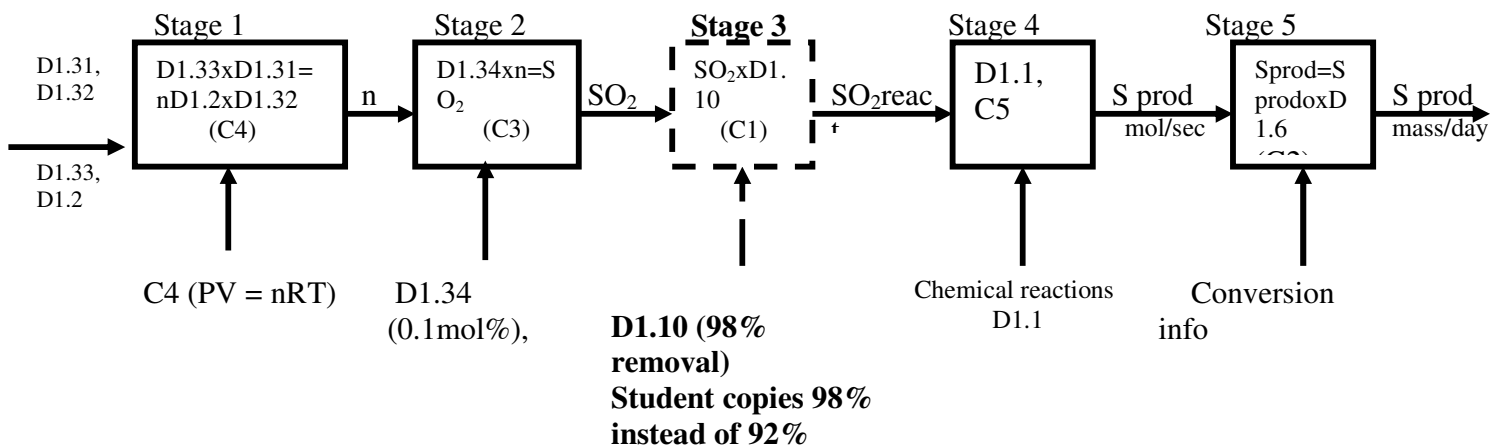

The error student B makes is that instead of writing 92%, she writes 98%. This is a content error. Stage 4 therefore is fed incorrect content. All data generated after that is compromised. Her form is sound. She effects the right transformations, uses appropriate representations and uses all the data at the right stages in the right logic. This response is therefore relational. She has used all data given (despite copying down 98% instead of 92%); the transformations and representations are sound.

### 7.2.3 Student C

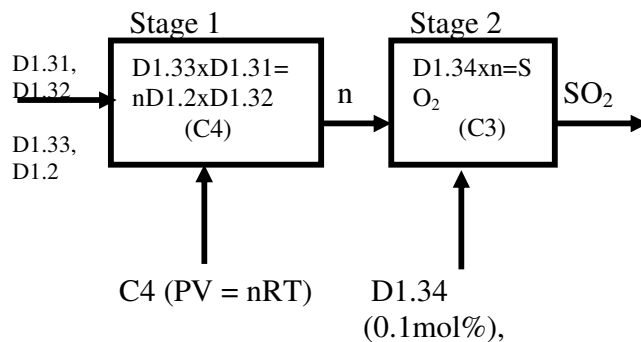

According to the above structure, student C has only completed two transformations instead of five. The little she has put down is appropriate in terms of both form and content. The transformations and representations are appropriate. However due to the incompleteness of the solution this response is unistructural.

### 7.2.4 Student D

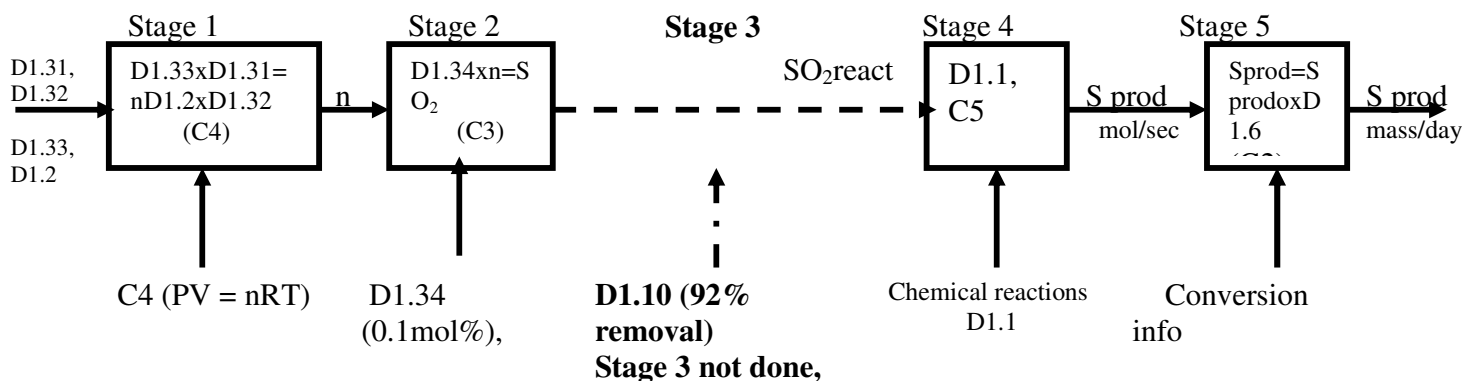

Student D misses out on the third piece of data for the third stage. This is a content error. Therefore, stage 4 is fed incorrect content or input. In stage 4 she transforms incorrect input and thus she generates incorrect content. This is despite making appropriate transformations using appropriate representations and data. Her form is sound; she uses all other data (except D1.10, which is content for stage 3) and effects the appropriate transformations in the right order. She does not violate any principles. This response is therefore multistructural.

### 7.2.5 Student E

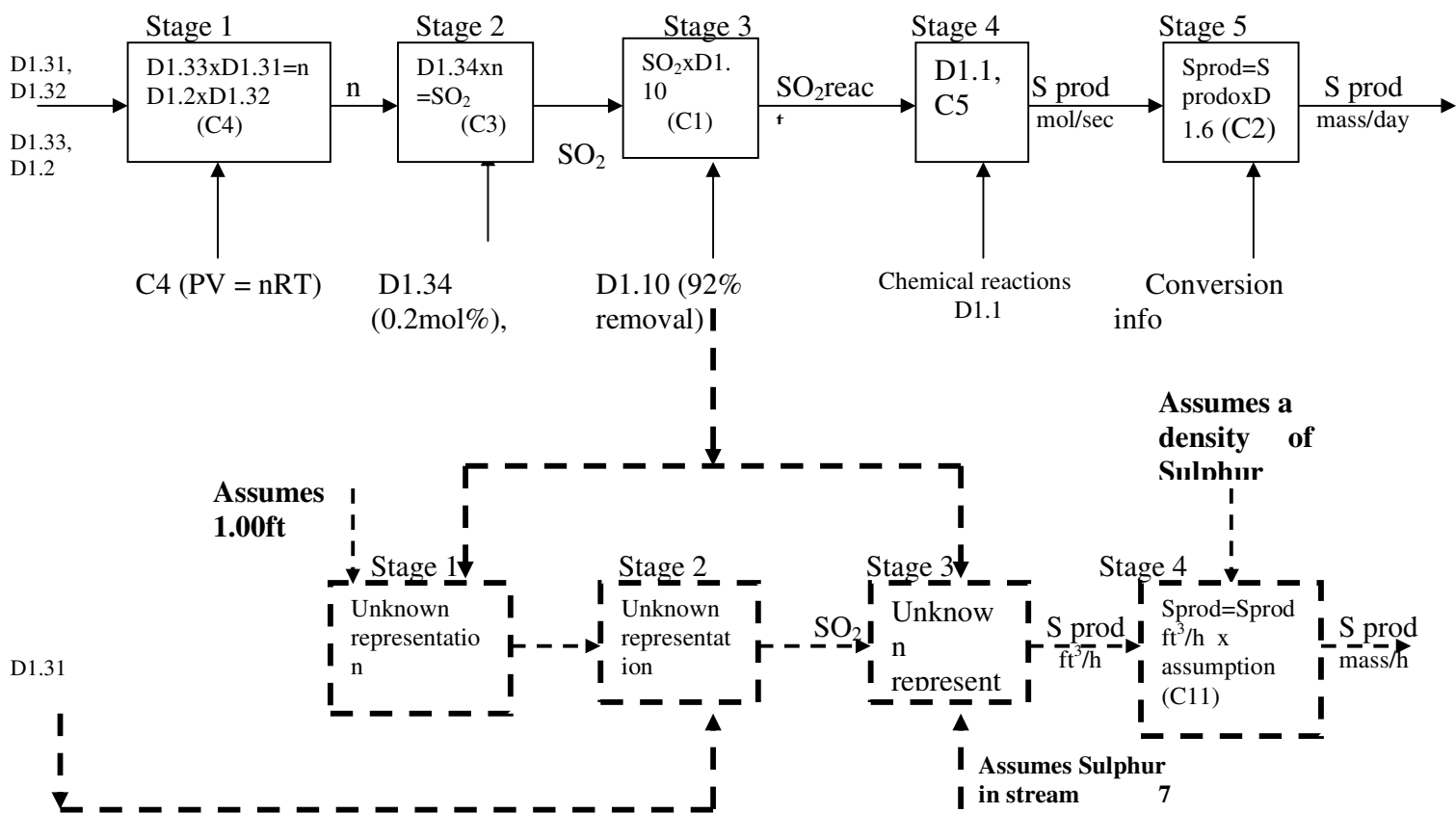

Student E uses only one piece of data i.e. (D1.10) and uses it inappropriately. This is a content error. All four transformations are invalid; the first three because incorrect content has been used and generated using invalid representations, and the fourth because the representation transforms incorrect input even though it itself is valid. The form is

therefore also problematic. This response is therefore prestructural mainly due to the invention of data and representations.

### 7.2.6 Student F

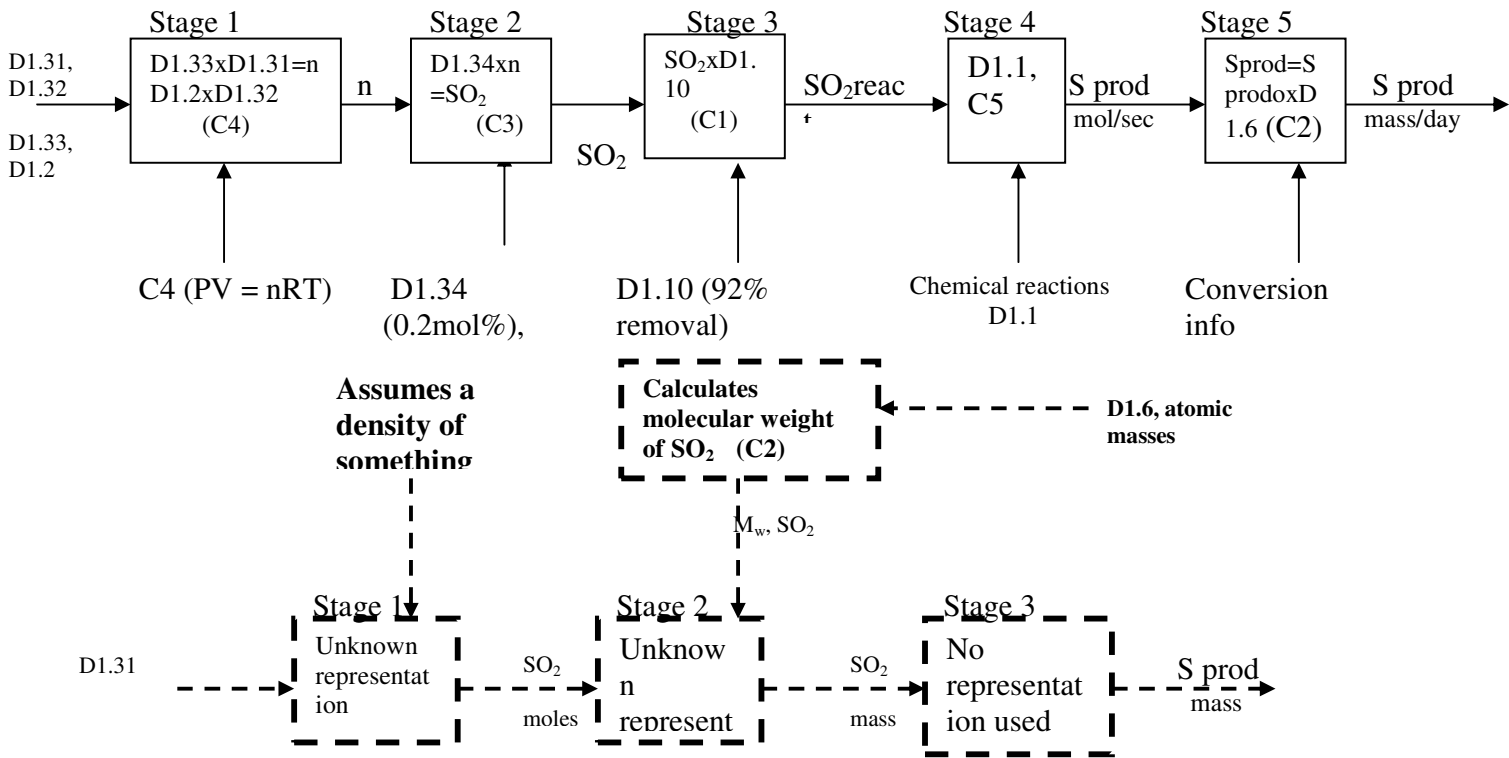

Student F has used none of the relevant or given content. This is a content error. All four transformations are invalid; the first three because incorrect content has been used and generated using invalid representations, and the fourth because the representation transforms incorrect input (content) even though it itself is valid. The form is therefore also problematic. This response is therefore prestructural mainly due to the invention of data and representations.

### 7.2.7 Student G

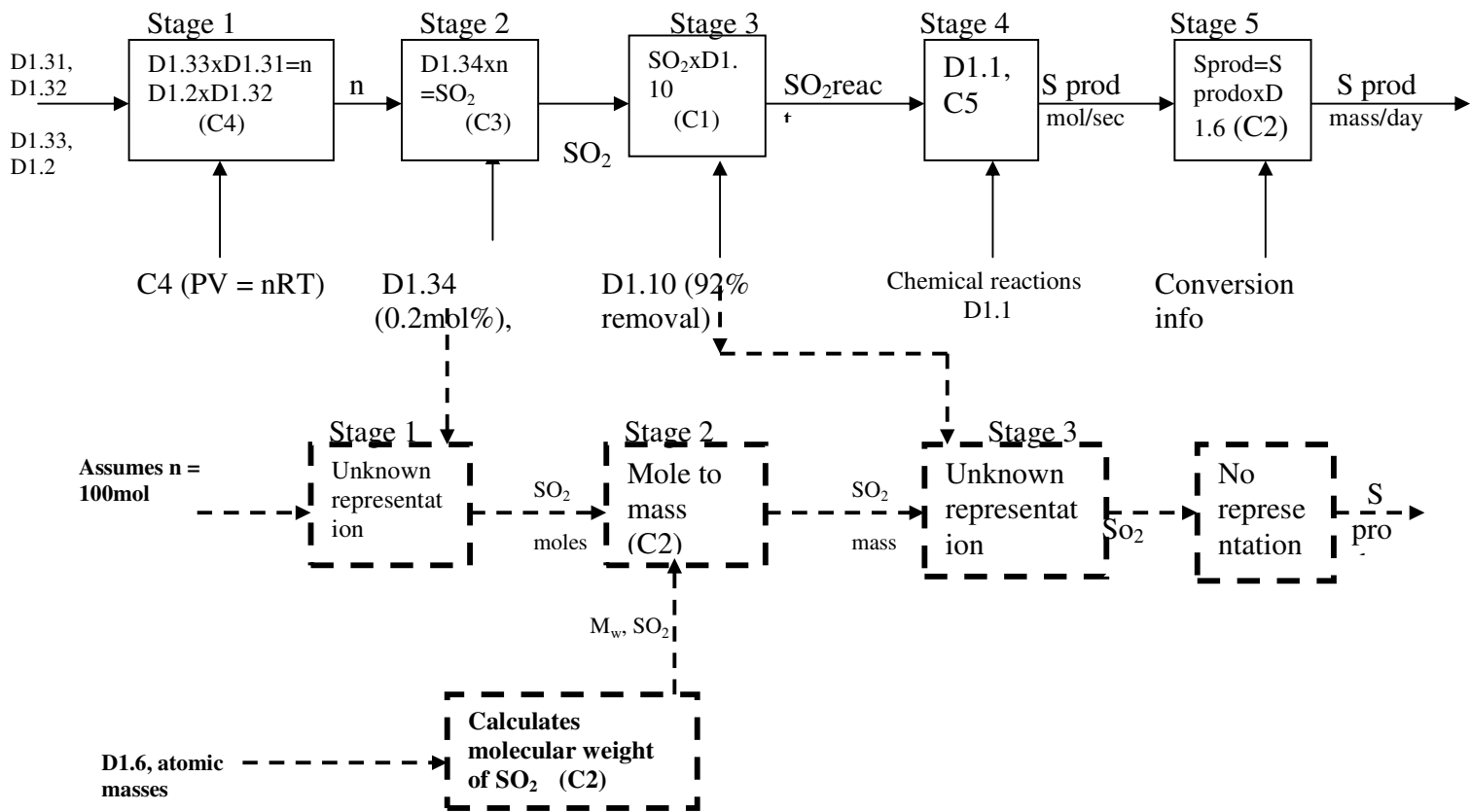

Student G has used two pieces of given content and has used them incorrectly. This is a content error. The transformations 1 and 3 are invalid because incorrect content has been used and generated using invalid representations. The rest of the transformations are also invalid because the representations transform incorrect input even though they themselves are valid. The form is therefore also problematic. This response is therefore prestructural due to the invention of data and representations.

### 7.2.8 Student H

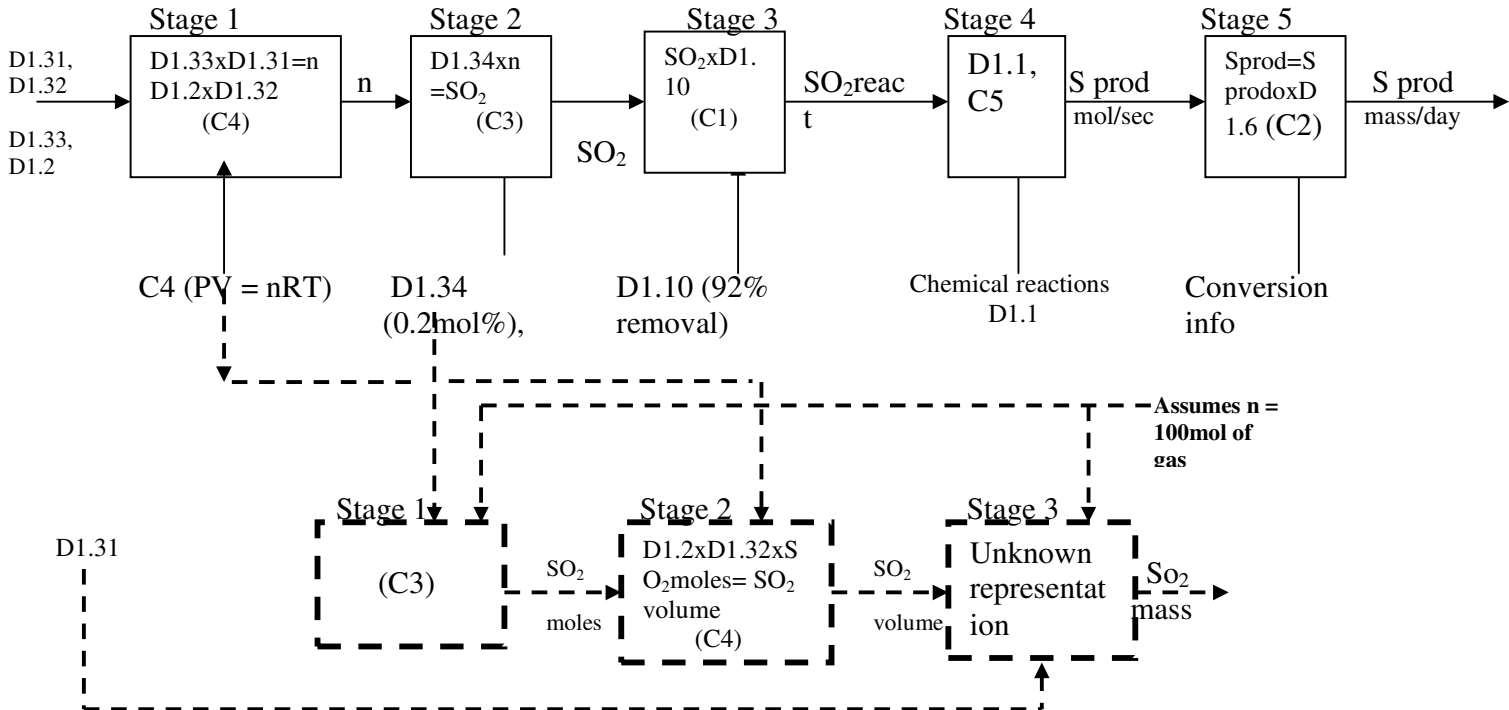

Of all the appropriate data given, student H chooses only (D1.34) and C4, and uses both inappropriately. This is a content error. All three transformations are invalid; the third because incorrect content has been used and generated using invalid representations, and the first two because the representations transform incorrect input even though they are valid. The form is therefore also problematic. This response is therefore prestructural mainly because of the invention of data and representations.

### 7.2.9 Student I

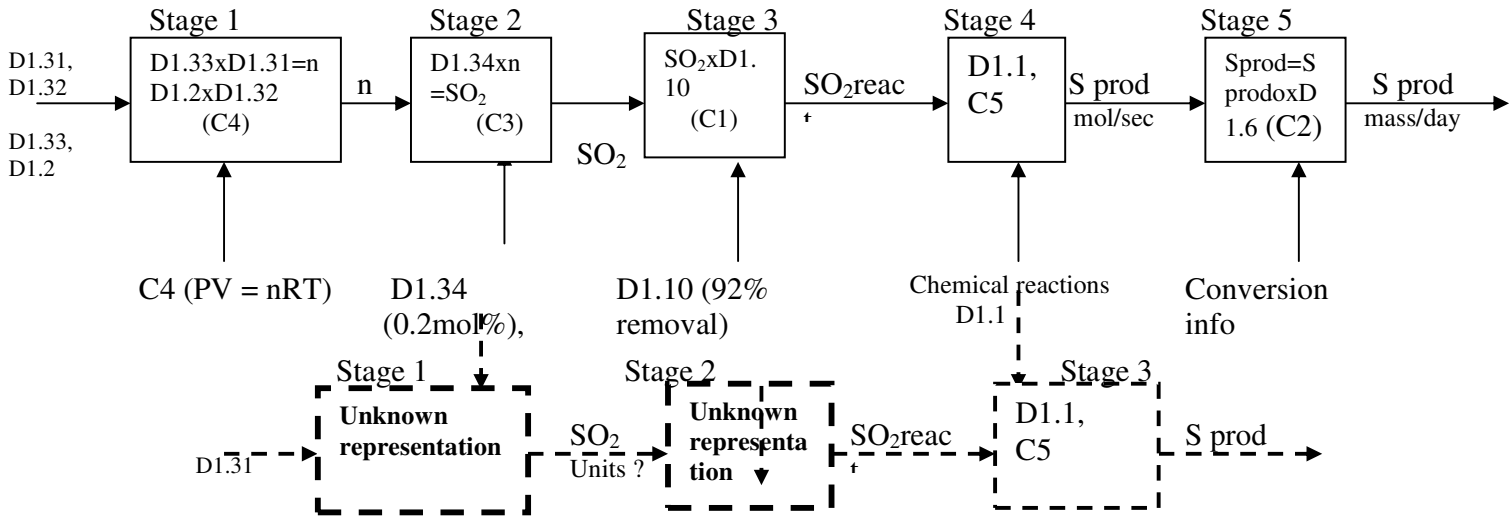

Student I uses three pieces of data from what's given. However none of it has been used appropriately. This is quite a severe content error and leads to form being compromised. All three transformations are invalid. The first two because the student uses and generates incorrect content using inappropriate representations; and the last because even though the representation is valid, the transformation becomes invalid. This response is therefore prestructural mainly due to the invention of representations.

### 7.3 Results – Question 4

This question is slightly different to the previous question. The response is not linear. The key lies in the connections among the products of the transformations. The only representations that are necessary are  $\frac{m}{v} = \rho$  (C11),  $\frac{\rho a}{\rho w} = SG$  (C7/8) and  $m_t = m_a + m_b$  (C10), where t is the mixture, w is for water and a and b are the constituents of the mixture. These three are related and connected several times to generate the solution. In the ideal response the first representation is used a number of times, the second only once and the third only once. The third representation is the connecting representation and connects the products of the second and the first representation after it has been done the appropriate number of times. If a student uses representation other than these, the form is compromised as the relevant connections will not be made.

#### **Response categorisation**

**Relational** – C7/8 has been used. C11 has been used enough times and the connections made through C10. This response has no invalid or invented content or representations that would compromise the form. This response is therefore sound in both form and content.

**Multistructural** – C7/8 has been used. C11 has been used enough times but the connections have not been made through C10. This response has no invalid or invented content or representations. However since C10 is not used the form is compromised. This response is therefore not sound in form and content.

**Unistructural** - C7/8 has been used. C11 has not been used enough times and the connections have not been made through C10. This response may include invented data or representations. It is therefore not sound in form or content.

**Prestructural** - C7/8 has not been used. C11 has not been used enough times or at all and the connections have not been made through C10. This response includes invented data or representations. It also includes data generated that does not get used. It is therefore not sound in form or content.

### 7.3.1 Student A

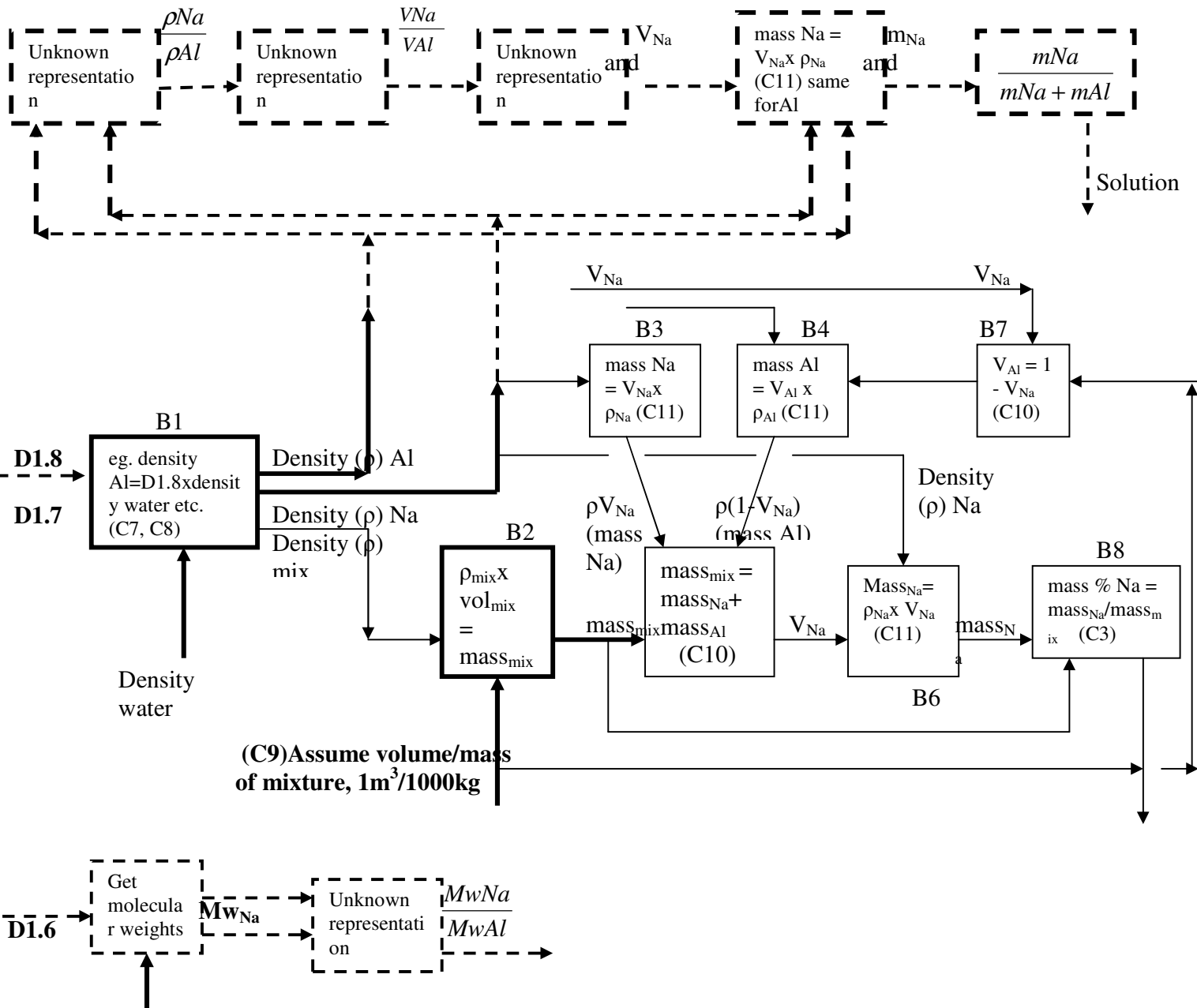

**Na<sub>2</sub>O and Al<sub>2</sub>O<sub>3</sub>**

According to the above structure, student A starts on the right track. However, her B2 transformation generates correct content, which she does not use. She uses the B1 content in a series of invalid representations. This response is problematic in content, which compromises the form. She only uses the second of the three representations, uses the

first representation only once and does not use the third at all. This response is therefore prestructural because even though she starts at the right place she does not use some of the content (i.e. the representations); she does not do the necessary transformations and connections; she invents representations and she uses content from two transformations that are not connected to the rest of the process.

### 7.3.2 Student B

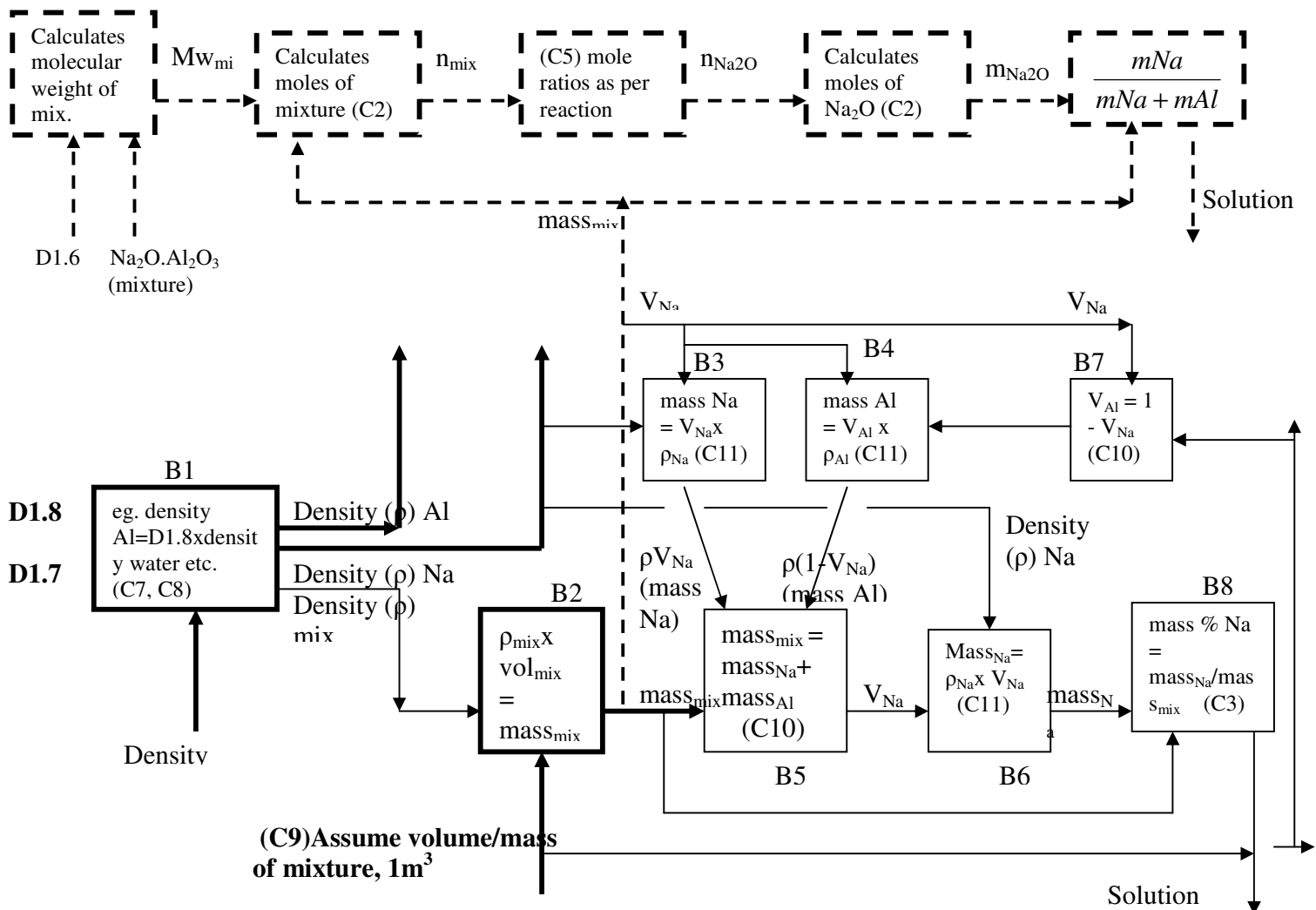

According to the above structure, student B starts on the right track. However her B2 transformation (using the first representation) generates correct content which she uses inappropriately along with content generated from B1 (using the second representation) in a series of invalid representations. She does not use the third representation at all. She

has also introduced new data. This response is therefore unistructural because even though she starts at the right place she does not use some of the content (i.e. the representations) and she does not do the necessary transformations and connections. She does not invent any representations. Therefore, her response is not prestructural.

### 7.3.3 Student C

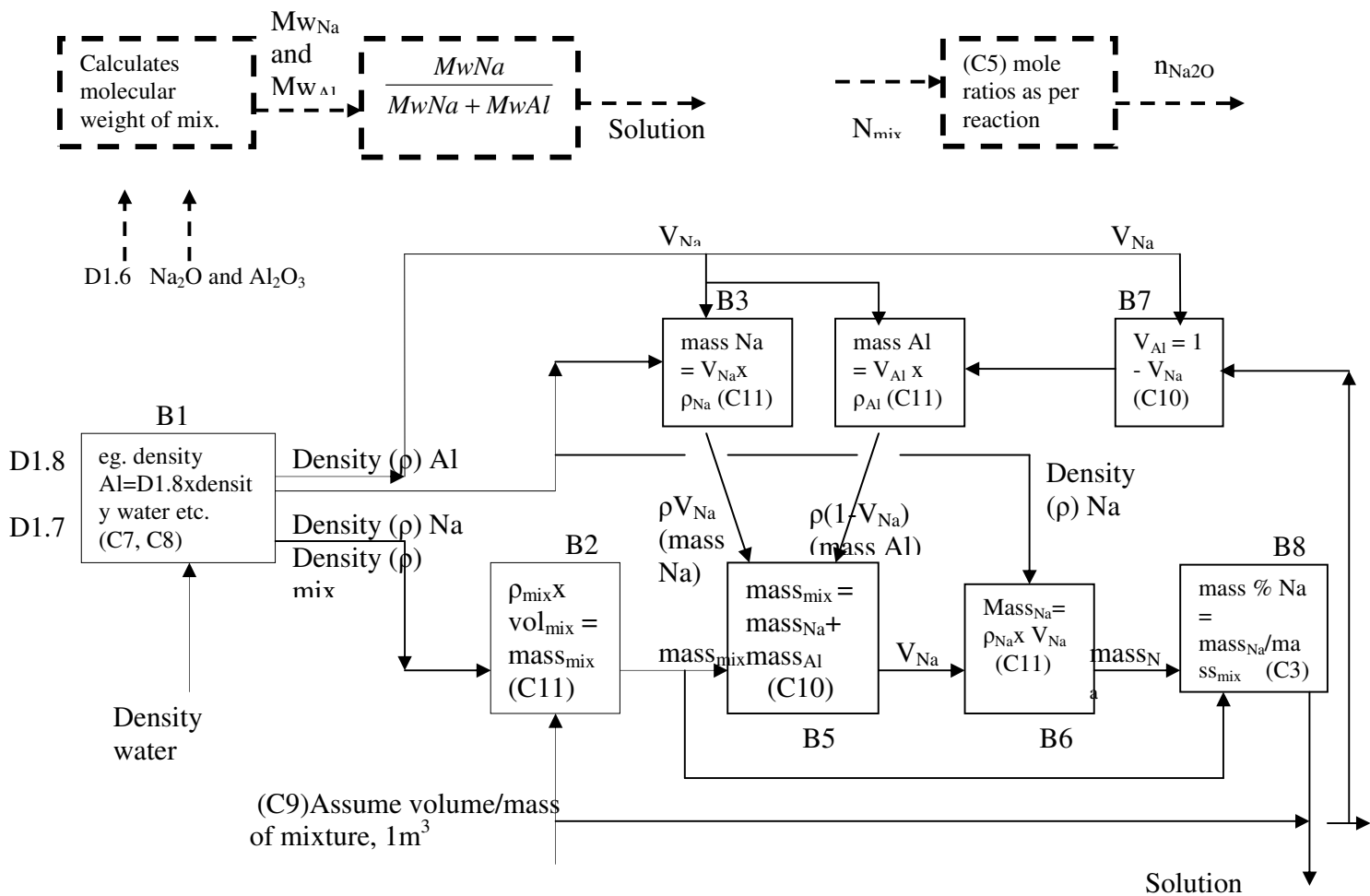

Student C uses none of the three representations necessary. This is a content error. As such, her transformations are not valid. The connections she makes are also not valid. Additionally, she does not start at the right point. Therefore, this response is prestructural.

### 7.3.4 Student D

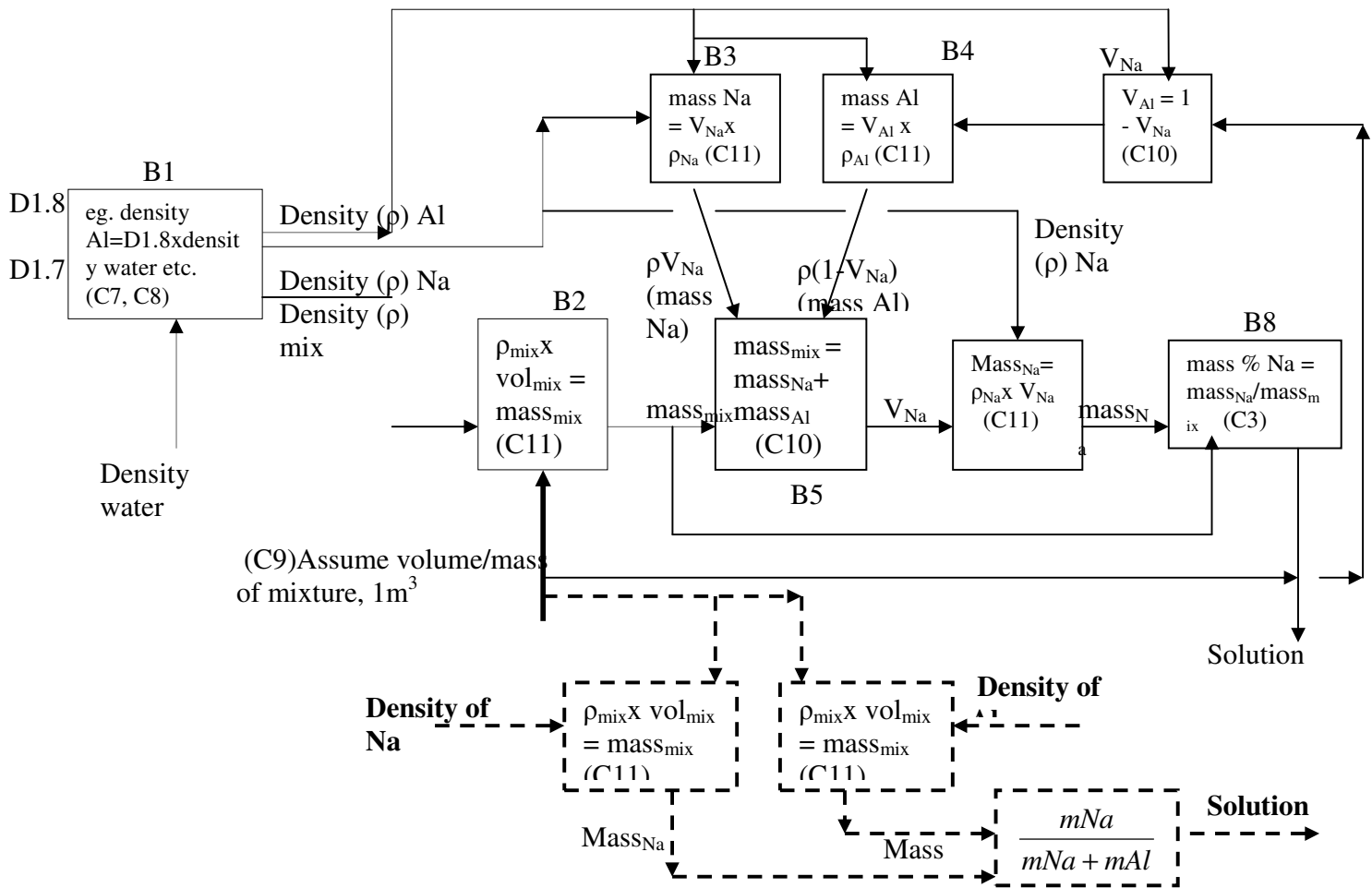

The student starts with an assumption that needed to be used in the B2 transformation. However she uses it inappropriately, using content generated from the B1 transformation. She uses the second representation (C7/8), and the first (C11). However she fails to connect them properly using C10. She does not use C11 enough times however otherwise her response would be multistructural. Her response is therefore unistructural.

(Student E has not attempted this question)

### 7.3.5 Student F

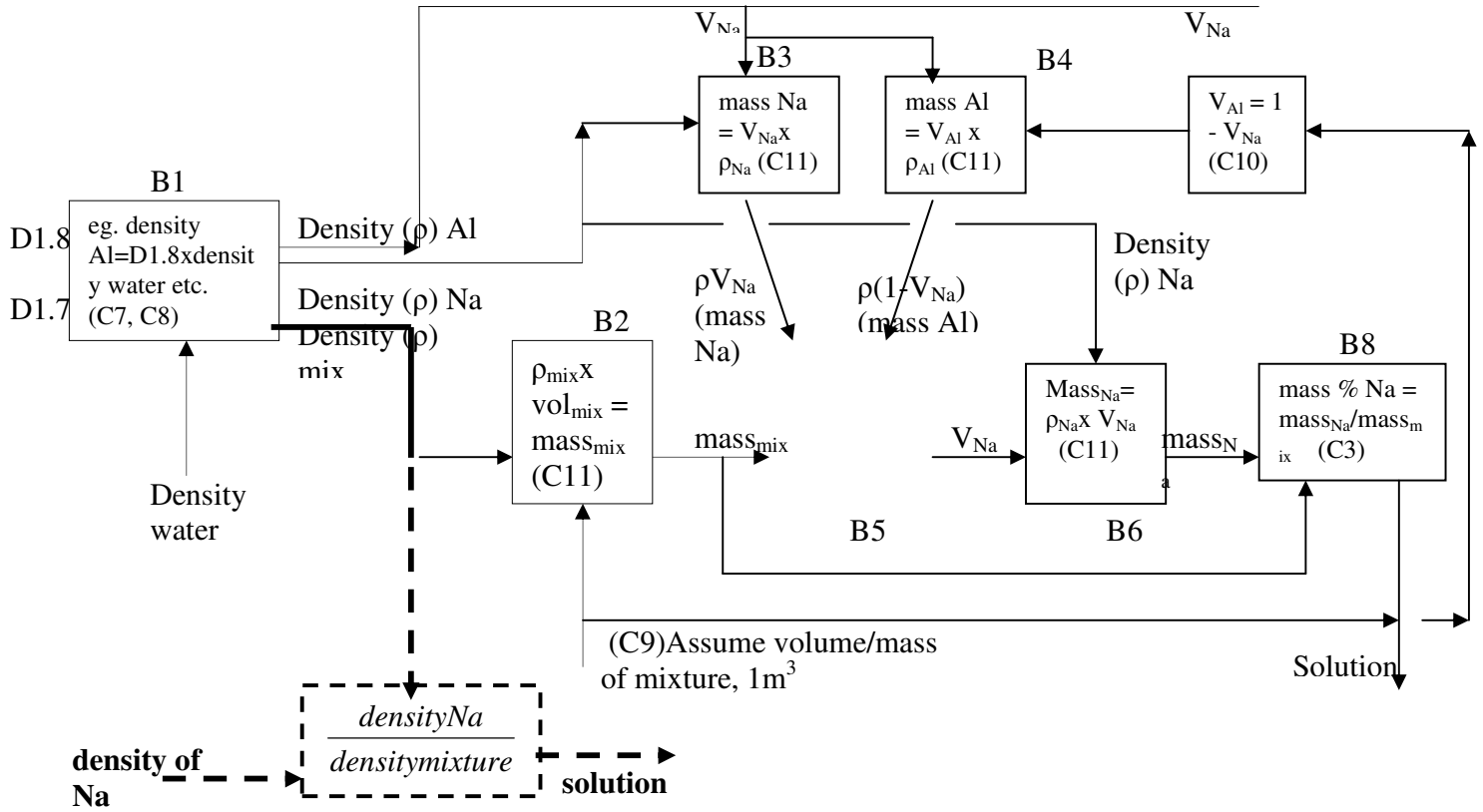

Student F uses C7/8. The products of C7/8 are transformed to the solution using an invalid representation. This response is therefore prestructural.

### 7.3.6 Student G

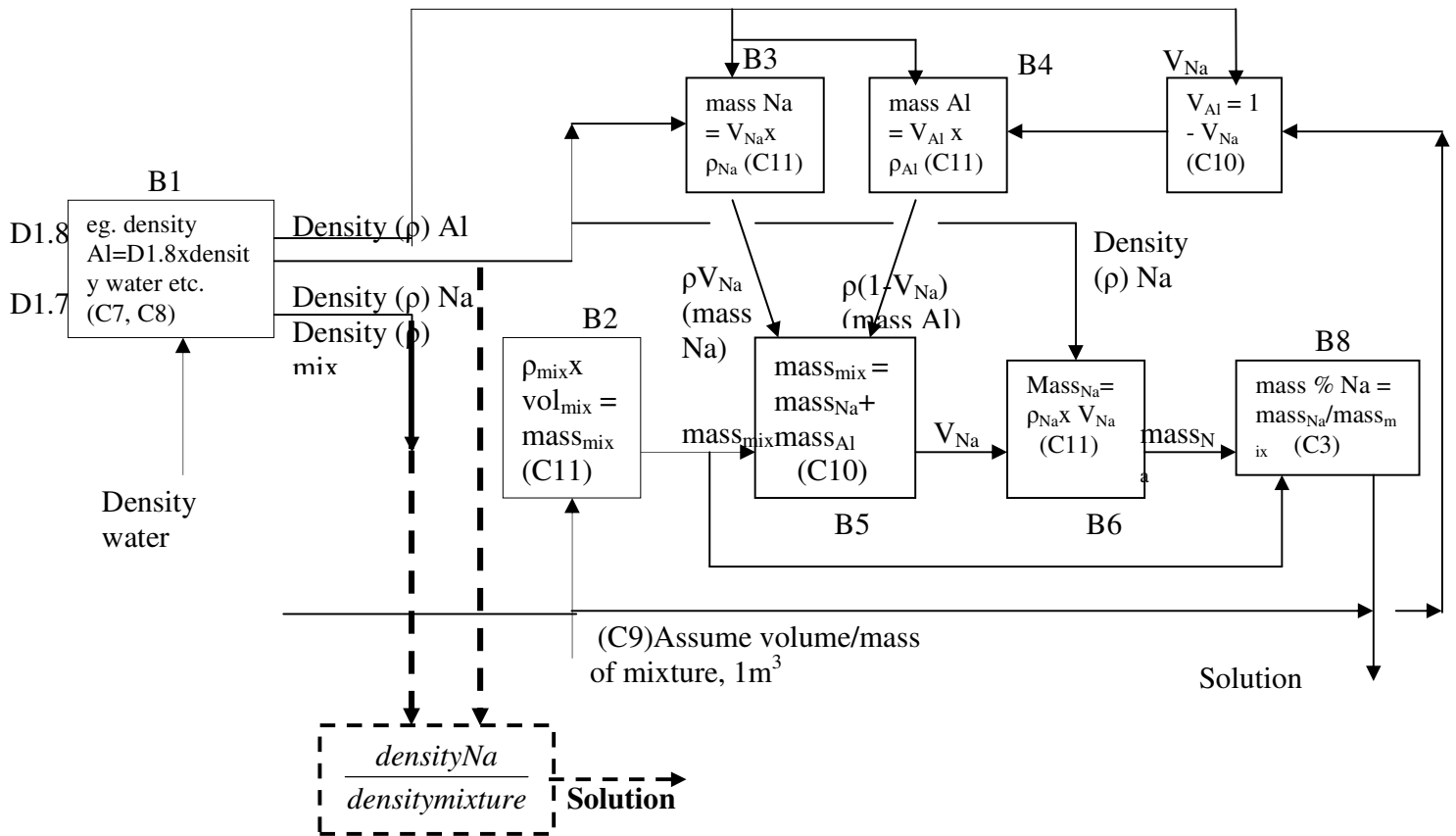

Student G uses C7/8. He transforms the products of C7 and C8 to the solution using an invalid representation. This response is therefore prestructural.

### 7.3.7 Student H

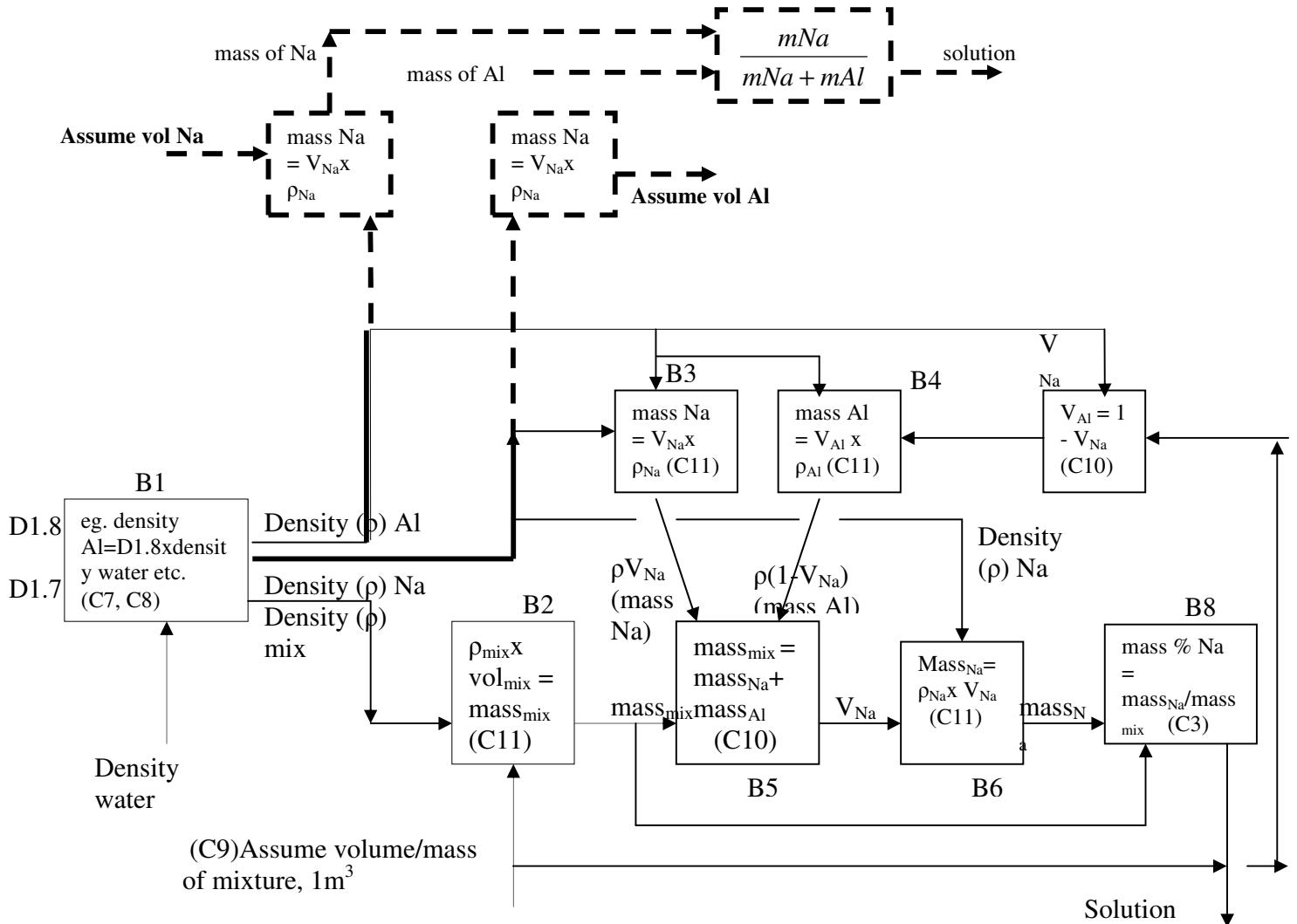

Student H uses the products of the B1 transformation inappropriately. He invents data, uses (C11) and tries to connect the products of the transformation using an inappropriate representation. This response is therefore prestructural.



comments about the response. At the end of the table a summing up comment is made and the response declared prestructural, unistructural, multistructural etc.

Because the question asks the students to give the function of each unit process (piece of equipment) from the flowsheet, each explanation given for the unit process is commented on and classified as either prestructural, unistructural, multistructural and so on. The entire response is then classified according to the level of connectivity achieved from the individual explanations and from here classified again as either prestructural, unistructural and so on.

### **Response categorisation**

The students' responses have been broken down into numbered statements and appear under the response column on the table. The percentage of misconceptions, redundant or partial ideas (incomplete ideas) from the students' total number of statements made, is calculated. Based on these the responses are classified. If statement 3 under the response column is a misconception, then the entry under the misconception column will be '3. Misconception'. If statement 2 is redundant, the entry under the redundant column will be '2. Redundant', and so on. The number of statements is immaterial. The essence of the function of the unit could be captured in one well-structured sentence. If most of the statements i.e. more than 40% of the total number for each, are misconceptions or are redundant, the response is weakened.

**Relational** – This response has no misconceptions, or redundant statements. The statements from each individual unit have been connected to give a complete idea of what is happening in the entire flowsheet.

**Multistructural** – This response has at most 1 misconception or the misconceptions account for 20% or less of the total. The redundant statements account for 20% or less of the total number of statements made. It also has partial ideas. However the statements from each individual unit have not been connected to give a complete idea of what is happening in the entire flowsheet.

**Unistructural** – The misconceptions or redundant statements account for between 40 and 60% (combined) of the total number of statements made. It also has partial ideas and the

statements from each individual unit have not been connected to give a complete idea of what is happening in the entire flowsheet.

**Prestructural** – This response has misconceptions, redundant statements and has no partial ideas. The statements from each individual unit have not been connected to give a complete idea of what is happening in the entire flowsheet.

### 7.4.1 Student A

<b>Boiler</b>					<b>Comments</b>
<b>Response</b>	<b>Misconception</b>	<b>Redundant</b>	<b>Partial Idea</b>	<b>Reactions mentioned</b>	
1. To clean and remove dust from the coal by boiling water 2. Oxygen is also present when this process is occurring <i>Prestructural – neither of these two is relevant and student misses the relevant reaction.</i>	1. Misconception.	2. This statement is redundant; gives no useful information about the unit.		None	1. Boiling the water will not and does not remove dust from the coal. The boiling of the water is a secondary step that happens after the combustion reaction has happened. 2 Oxygen mentioned - no reason given for its presence.
<b>Dust Extractor</b>					
1. To remove any dust that is still present in the coal. <i>Unistructural</i>			1. Partial idea.		1. The dust extractor acts on the gas, not the coal. The dust is removed from the gas not the coal. The coal has been burnt.
<b>Absorber</b>					
1. To mix the absorbent in the presence of a large surface area. <i>Prestructural</i>			1. Partial idea.	Reaction one.	Awkward expression. No indication of what the absorbent mixes with and why.
<b>Unit P</b>					

<p>1. Combustion reaction. 2. By producing sulphur, pollutants discharged to the atmosphere can be minimised. <i>Unistructural – too general and vague to add real meaning.</i></p>		<p>2. Redundant.</p>		<p>None.</p>	<p>Reaction more oxidation than combustion. Combustion is often associated with fuel reacting with oxygen.</p>
<b>Unit Q</b>					
<p>1. The purpose of the unit is to produce CO to aid in the formation of the alkalised alumina <i>Unistructural – idea not quite accurate enough.</i></p>			<p>1. Partial idea.</p>	<p>None.</p>	<p>The alkalised alumina is not ‘formed’; it is regenerated or restored to allow it to be able to load more gas. Essential here is also the production of hydrogen.</p>

<p>1. The function of the unit is to provide a large surface area so that the gases can mix with the absorber phase. <i>Prestructural – no relevant point made and the student misses a reaction.</i></p>	<p>1. Misconception.</p>			<p>Reaction 4.</p>	<p>The unit facilitates the regeneration of the absorbent through the appropriate reaction, and restores the absorbent to its original sulphur free state so that it will load more gas after it has been recycled. For this to occur, a large surface area is useful. Mention of gases mixing made, given the confusion about what the unit does, it's unclear exactly which gases are referred to.</p>
<b>Unit M</b>					
<p>1. The purpose of this unit is to alkalise the absorbent in the presence of H<sub>2</sub>. <i>Prestructural – no relevant point is made here and student thinks that reaction 3 is occurring here.</i></p>	<p>1. Misconception.</p>			<p>Reaction 3.</p>	<p>This is a separation device, possibly a cyclone, where whatever absorbent is entrained with the rising gas stream is trapped and redirected to stream 14. There is possibly further reaction 1</p>

					happening here due to the contact between the offending gas stream and absorbent particles. Stream 27 has therefore very little SO <sub>2</sub> while stream 14 has absorbent present due to the separation in unit M. The phrase 'to alkalisise the absorbent' is problematic. It has no real meaning.
--	--	--	--	--	---

**General comments**

The student has a total of 9 statements. Of these, 3 are misconceptions, 3 are partial ideas and 2 are redundant. There is a general lack of precision in the responses. The student does not seem to have looked at the mass balance table or the list of reactions properly to help make a decision about the next stage of the process. The key factors that set each unit apart from the others have not been highlighted. The results are very vague statements that do not give a real idea about each unit. The response is therefore unistructural.

**7.4.2 Student B**

Boiler					
Response	Misconception	Redundant	Partial idea	Reactions	Comments
1. Heats the gas to prepare it for subsequent processes downstream <i>Prestructural.</i>		1. Vague, no real meaning.		None	Not clear what 'gas' refers to in this statement.

					Very vague also.
<b>Dust Extractor</b>					
2. Removes all traces of the dust present in the gas that comes from stream 6 to give dust free stream 7. <i>Relational</i>					
<b>Absorber</b>					
1. Receives the gas stream containing SO <sub>2</sub> to be removed. 2. To enable the SO <sub>2</sub> to be mixed with the absorbent by means of turbulence and a spray of solid phase absorbent <i>Unistructural – one relevant point is made.</i>				Reaction 1.	2. Mechanism put forward not accurate. The student has confused this idea with a different one in a different problem. The notion of “spray” gives this away.
<b>Unit P</b>					
1. Receives stream 18 (the gases) and stream 24, air. 2. Stream 22 contains traces of less harmful pollutants while stream 23 contains sulphur. 3. Separates the gases from the sulphur to be sold. <i>Prestructural – the first two points do not add real value to the solution. The last point is not accurate.</i>	3. Misconception.	1. and 2. Redundant.		None.	Function of the unit not given. The unit converts H <sub>2</sub> S to the less harmful Sulphur, which can then be reused. Water vapour is

					the other product. The unit does more than just separate the sulphur from the gases.
<b>Unit Q</b>					
1. Allows for a reaction to occur to form H <sub>2</sub> and CO. 2. Which are used in Unit N to produce less harmful pollutants. <i>Relational – it's brief but all the essentials are there.</i>				None.	
<b>Unit N</b>					
1. Receives fine absorbent particles and stream 19 from unit Q. 2. It allows for reaction 4 and 3 to take place while recycling solid absorbent. <i>Unistructural – point two is fine but mention could have been made of what the reactions actually do and why. This would have captured the essence of the function of the unit.</i>		1. Redundant.	2. Partial idea.	Reactions 3 and 4.	The essence of this unit is that it regenerates the absorbent, getting it ready to go back to the absorber for further contact with the offending gas.
<b>Unit M</b>					
1. It separates the absorbent from the gas stream that contains clean gas, free from most of the SO <sub>2</sub> , 2. Whereby the clean gas is taken out of the process and recycling absorbent is sent back to the process. <i>Multistructural – the first point makes a strong statement but the second part of the second point is vague. Essentially the general idea is captured in point 1 but</i>		2. Redundant.		None.	The point is to ensure that no loaded absorbent is caught up in the exit gas stream

<i>does not get elaborated on.</i>					and thus lost.
------------------------------------	--	--	--	--	----------------

**General comments**  
 The student makes a total of 13 statements. Of these 1 is a misconception, 5 are redundant and 2 are partial ideas. 54% of the ideas about what the units do are correct yet lack a “firm statement” that gives straightaway an idea of what the unit does. In some cases the student makes obvious statements that are not credit bearing i.e. the redundant statements. Without these the response would be multistructural. Otherwise it is unistructural.

### 7.4.3 Student C

Boiler					
Response	Misconception	Redundant	Partial ideas	Reactions	Comments
1. Coal and air are boiled in water. 2. Since it is boiling, temperatures are up the water is converted into steam. 3. From the boiling of coal and air in water, ash forms. 4. Because ash forms, this unit could be doing some cleaning on the solid component of the feed, coal. 5. The feed here is water, coal and air and the products are steam, ash and the desired product of the processing unit. <i>unistructural – Partial ideas compromised by</i>	1. Misconception. 4. Misconception.	5. Redundant.	1. Partial idea. 2. Partial idea.	None.	Coal is burned in air with the heat from that reaction being used to convert water to steam. It is not clear what she means by the “desired product” in the last line.

<i>the misconceptions.</i>					
<b>Dust Extractor</b>					
1. The desired product of the boiler is fed to the dust extractor where the dust is removed from it to form a dust free product of the unit. <i>Relational</i>					Desired product not specified.
<b>Absorber</b>					
1. Because this is the first unit with the absorbent, this is the first place where the conversion of SO <sub>2</sub> to Sulphur happens. Streams 10 and 17 are the feed and streams 16 and 13 are the products. 2. The coal, which is carbon, is mixed with some of the steam from the boiler to give hydrogen and carbon monoxide gases. 3. Since two moles	2. Misconception . 3. Misconception .			Reactions 1 and 2.	Assumption is that the reaction that actually takes place in unit Q happens in Unit L, such that she posits two reactions in this unit as opposed to just the one. 3. The idea of one mole of the product from reaction one leaving at the top and the other mole at the bottom of the absorber is not feasible; it does not make sense.

<p>of absorbent were formed, 1 mole leaves the unit in stream 16 with hydrogen to unit M. The other mole leaves as stream 13 with CO.</p> <p><i>Unistructural – the first point is fine but the last two are highly inaccurate.</i></p>					
<b>Unit P</b>					
<p>1. H<sub>2</sub>S from unit N is the feed together with air (which should have a lot of oxygen).</p> <p>2. The desired product, sulphur, is formed and leaves as stream 23 while the steam leaves as stream 22.</p> <p><i>Unistructural –2 does not give anything of value.</i></p>		2. Redundant.	1. Partial idea.	None.	<p>H<sub>2</sub>S is not the feed exactly. The gas product from Unit N contains H<sub>2</sub>S, among other things, which reacts with the air fed into the unit. There is no mention of the significance of this.</p>
<b>Unit Q</b>					
<p>1. This could be some kind of dust extractor with coal and air coming in freed of dust and leaving as stream 19 to unit N.</p> <p><i>Prestructural – no relevant detail given and no reaction given.</i></p>	1. Misconception .			None.	<p>Inaccurate. This is a water gas formation unit. Coal and water to form CO and H<sub>2</sub>, which will help, regenerate the absorbent. The student seems to think, possibly from her conception of the boiler, that wherever there is coal, dust will be extracted from it. This is of concern as there is no outlet stream from this unit that is labelled ‘dust’.</p>

<b>Unit N</b>					
<p>1. are streams 15 and 19, and the product streams are streams 18 and 20.</p> <p>2. The CO from stream 15 reacts with the loaded absorbent (the other mole from the absorber) and some of the steam from unit M.</p> <p>3. Stream 19 does not have absorbent implying that its components need some absorbent in some way, which can be obtained in unit N.</p> <p>4. So in unit N some virgin material is mixed with the absorbent and also leaves in stream 20.</p> <p><i>Prestructural – none of these points are relevant. The student also misses a reaction that occurs here. She only mentions one.</i></p>	<p>2. Misconception</p> <p>. 3. Misconception</p> <p>. 4. Misconception</p> <p>.</p>	<p>1. Redundant.</p>		<p>Reaction 4.</p>	<p>Generally because the student has misinterpreted the functions of all the units surrounding this one, she misinterprets this one as well. The CO and the steam are in fact from stream 19, the reaction products of unit Q, not from streams 15 and unit M as she says. For this reason, stream 19 does not have any absorbent. It's fresh as it has had no contact with absorbent containing streams. It's not clear what she means by the 'virgin material', or in fact why it needs to be mixed with the absorbent.</p>
<p>1. The hydrogen and absorbent are fed as stream 16 and react according to reaction 3.</p> <p>2. Some of the steam leaves as stream 27 and some with H<sub>2</sub>S and loaded absorbent.</p> <p><i>presrtuctural –</i></p>	<p>1. Misconception</p> <p>. 2. Misconception</p> <p>.</p>			<p>Reaction 3.</p>	<p>This is all inaccurate. The unit simply separates absorbent trapped in the gas stream and recovers it to stream 14, while the gas depleted of SO<sub>2</sub> exits through stream 27.</p>

<i>none of these are relevant and the student further suggests that a reaction is happening when none is.</i>					
---	--	--	--	--	--

**General comments**

There are 18 statements in total. 10 of these are misconceptions (56%). 3 Are redundant and 3 are partial ideas. The student does not seem to have examined the flowsheet and the mass balance table properly. There is very little consistency in the responses. In other words, interpretations that she puts forward for a unit do not agree with the logic of the entire flow sheet. This response is therefore prestructural.

**7.4.4 Student D**

<b>Boiler</b>					
<b>Response</b>	<b>Misconception</b>	<b>Redundant</b>	<b>Partial idea</b>	<b>Reactions</b>	<b>Comments</b>
1. This is some kind of furnace in which coal is burned to produce a gas. 2. The addition of air is to help with the combustion of coal. 3. A water stream is used to cool down the gas and it leaves the unit as steam. 4. Cooled gas exit the unit through stream 6. <i>Unistructural – although she has two relevant points, she does not connect them and she also misses or does not indicate what reaction is occurring in this unit.</i>	3. Misconception.	4. Redundant.	1. Partial idea. 2. Partial idea.	None.	3. The third point is rather interesting. Instead of the energy from the combustion reaction being used to heat the water to produce steam, the water cools down the gas and leaves as steam. But what she fails to consider is the possibility of the gas

					condensing on cooling. Point 4 does not say anything of value.
<b>Dust Extractor</b>					
<p>1. Feed is cooled gas filled with particles.</p> <p>2. The gas from the boiler enters the dust extractor so that the dust particles can be removed.</p> <p>3. This unit works like an electrostatic precipitator, whereby charged rods or plates in the unit attract the dust particles from the gas and discharge them at the bottom so that dust-free gas proceeds to the other units.</p> <p><i>Relational.</i></p>			1. Partial idea.		Point 1 compromised by the information about the boiler. Point 3 does not add value; it's unnecessary detail.
<b>Absorber</b>					
<p>1. Dust free gas is fed to the absorber so that SO<sub>2</sub> can be absorbed from the gas.</p> <p>2. This process occurs in the presence of a scrubbing solution, which in this case is a solid phase.</p> <p>3. The gas with less SO<sub>2</sub> is forced upwards (pneumatically transported) and sent to unit M.</p> <p>4. The absorbent leaves the unit through stream 13.</p> <p><i>Multistructural</i></p>		4. Redundant.		Reaction 1.	Calling the solid phase a scrubbing solution is contradictory. This particular process is a dry process. She has carried over ideas from a previous exercise that used a wet absorbent. She has defined pneumatically transported as the gas moving upwards out of the absorber. That is not

					accurate. Whether the process is dry or wet the gas still exits at the top of the absorber. Pneumatic transportation accounts for the transporting of the absorbent particles elsewhere in the process.
<b>Unit P</b>					
1. The feed here is air and the gaseous products of unit N. 2. This is where sulphur is produced and other gaseous products proceed to other units through stream 22. <i>Unistructural – point two is the only one of real value.</i>		1. Redundant.	2. Partial idea.	Reaction 5.	Vague. No mention is made of the trace amounts of absorbent that leave with the other gaseous products.
<b>Unit Q</b>					
1. Coal and water vapour are the feed. 2. The products are hydrogen and carbon monoxide. 3. They assist in the separation of the SO <sub>2</sub> from the absorbent. <i>Unistructural – point three is the most informative.</i>		1. Redundant. 2. Redundant.	3. Partial idea.	Reaction 2	Separation of the SO <sub>2</sub> from the absorbent is what she did not mention in the previous response for unit N. The word separation is not accurate here; something

					more substantial is happening than just a separation.
<b>Unit N</b>					
<p>1. The feed here is the SO<sub>2</sub> laden absorbent, flue gas from unit Q.</p> <p>2. In this unit SO<sub>2</sub> is removed from the absorbent by reacting the absorbent with hydrogen, and also with carbon monoxide and water.</p> <p><i>Unistructural –both points are valid but they are not connected and the student only mentions one of the two reactions that happen in this unit.</i></p>				Reaction 4.	Detail about what reactions do missing. That is the essence of this unit. The stripping that she mentioned as part of unit M actually happens in this unit.
<b>Unit M</b>					
<p>1. This unit is stripping the gas of stream 16, which still has an absorbent in it.</p> <p>2. It might be increasing the reaction between SO<sub>2</sub> and the absorbent so that a gas free of SO<sub>2</sub> is emitted.</p> <p>3. The product of this unit is an absorbent stream 14.</p> <p><i>Unistructural – point two might be right but the actual function of the unit has not been captured.</i></p>	1. Misconception.	3. Redundant.	2. Partial idea.	None.	Stripping is essentially the reversal of the reaction that happens in the absorber to recover the absorbent. This is not what happens in this unit. The last line is a bit awkward; it's not clear.

**General comments**

There are a total of 18 statements. 2 are misconceptions (11%), 6 are redundant and 6 are partial ideas. She has kept the responses quite simple, which means she does not get herself into trouble with too much uniformed speculation. The negative part to this is that she leaves out detail that is quite important to mention in some cases. The number of redundant statements makes a response that could have been multistructural, unistructural.

**7.4.5 Student E**

<b>Boiler</b>					
<b>Response</b>	<b>Misconception</b>	<b>Redundant</b>	<b>Partial idea</b>	<b>Reactions</b>	<b>Comments</b>
1. Water and coal and air are feeds into the boiler and ash is one of the products. 2. The coal was burnt. 3. Oxygen was extracted from the air. 4. Steam is also a product meaning that water was heated viz boiler and steam was produced. 5. Oxygen could also have been taken from the steam for the combustion of coal. 6. The other product is the gas produced in combustion of coal together with smoke and dust. 7. Thus its function is to burn coal and produce gases. <i>Multistructural – she makes several points, seemingly at random and with no connections, but misses a reaction that occurs in this unit.</i>	5. Misconception.	1. Redundant. 6. Redundant.	4. Partial idea. 7. Partial idea.	None.	The student acknowledges that coal was burnt but does not attribute the burning function to the air. Later on though she mentions that the oxygen could have been taken from the steam, and used to burn the coal. This idea is awkward.
<b>Dust Extractor</b>					
1. The feed are the gases produced in the combustion of coal, steam and dust. 2. The products are dust and stream 7, which must be dust free gases. 3. Thus the function of the dust extractor is to extract dust from the gases produced in the boiler and this dust is discarded. <i>Relational.</i>		1. and 2. are redundant.		None.	

<b>Absorber</b>					
<p>1. This is the absorption tower where there is the absorbent solid, which absorbs the SO<sub>2</sub> from the flue gas.</p> <p>2. The SO<sub>2</sub> free gas leaves this unit via stream 16 to unit M.</p> <p><i>Multistructural –no connectivity of ideas.</i></p>				Reaction.	Some detail about the mechanism of absorption could have strengthened this response.
<b>Unit P</b>					
<p>1. This unit receives H<sub>2</sub>S from unit N and has another feed stream 24, which must be O<sub>2</sub> so that it can produce products which are less harmless to the environment and that would not cause much damage.</p> <p><i>Unistructural</i></p>				Reaction 5.	Mention of the trace amounts of absorbent would have strengthened this response. This is important as there is a make-up stream further down the process the function of which is to replenish the lost absorbent. She later fails to identify the need of the make-up stream and this can be attributed to her not seeing that absorbent is lost through stream 22.
<b>Unit Q</b>					
<p>1. Coal and water mix in this unit to form carbon monoxide and hydrogen, which are needed in unit N for formation of absorbent.</p> <p><i>Unistructural</i></p>			1. Partial idea.	None.	The two products from this unit are used to reform or regenerate the absorbent and not to form it.
<b>Unit N</b>					
<p>1. This unit receives flue gas with SO<sub>2</sub> and the absorbent with SO<sub>2</sub> from unit L.</p> <p>2. It mixes with hydrogen to form the absorbent without the SO<sub>2</sub>.</p> <p>3. Only the H<sub>2</sub>S is removed via</p>	3. Misconception.	1. Redundant. 5. Redundant.		Reactions 3 and 4.	The main stream is the loaded absorbent stream. The gas is simply a carrier or a transporter. The

<p>stream 18.</p> <p>4. This unit mainly recovers the absorbent and CO<sub>2</sub> becomes part of the flue gas emitted.</p> <p>5. CO<sub>2</sub> used is formed in unit Q.</p> <p><i>Multistructural – some relevant points are made and the rest are weakened by awkward expressions. The level of connectivity is low to non-existent.</i></p>					<p>student does not appear to appreciate that difference fully. The absorbent without the SO<sub>2</sub> could be the stripped absorbent. Some absorbent is lost through stream 18 with H<sub>2</sub>S.</p>
<b>Unit M</b>					
<p>1. This unit receives the flue gas with less SO<sub>2</sub> since SO<sub>2</sub> was absorbed in the unit L, the absorber.</p> <p>2. SO<sub>2</sub> free flue gas goes out via stream 27.</p> <p>3. And flue gas with some SO<sub>2</sub> goes to join stream 13 via stream 14 so that it can be purified more of SO<sub>2</sub> since separation processes are never perfect.</p> <p><i>Prestructural - The stream that goes to join stream 13 via stream 14 is essentially solid loaded absorbent, not 'gas with some SO<sub>2</sub>' as she says.</i></p>	<p>3. Misconception.</p>	<p>1. Redundant.</p> <p>2. Redundant.</p>		<p>None.</p>	<p>Confusing. First, the flue gas free of SO<sub>2</sub> goes out through stream 27, and then it goes out to join steam 13 through stream 14. No mention is made here of the absorbent. Somehow she recognises that this unit separates streams but she does not identify the streams properly or what is being separated from what.</p>
<p><b>General comments</b></p> <p>There are 22 statements in total. 3 are misconceptions, 8 are redundant and 3 are partial ideas. The student gives adequate responses that are however compromised by the poor use of grammar. This response would have been strengthened by a careful analysis of the mass balance table and flowsheet. The number of redundant statements would have made this response unistructural. However because the student achieves a level of connectedness within the rest of the accurate responses 50% of the total number of statements, the response is multistructural.</p>					

### 7.4.6 Student F

Boiler					
Response	Misconception	Redundant	Partial Ideas	Reactions	Comments
1. Boils water to give off steam. 2. It burns coal to produce ash. <i>Unistructural – both points are valid. However they are not connected and she misses the one reaction that is occurring here.</i>			1. Partial idea.	Reaction 4.	Very brief and no connections made between the burning of the coal and the production of steam. She sees these two as separate events.
Dust Extractor					
1. Takes in air and separates it from the desired one. 2. And the unwanted air which is dust and takes dust free air to other units to be processed further – i. <i>Prestructural – none of these are valid.</i>	1. Misconception. 2. Misconception.				The unit does not take in air, but rather the gas from the combustion. She mentions unwanted air which she calls dust. Air seems to have two definitions; it is both the desired product, the gas, as well as the undesired product, the dust. There is obvious confusion here.
Absorber					
1. This is where the gas SO <sub>2</sub> is being mixed with the solid phase to produce less harmful product. 2. The chemical reaction that occurs here is reaction 1. <i>Unistructural –there really could have been much more detail added here.</i>			1. Partial idea.	Reaction 1.	The SO <sub>2</sub> is not being mixed with the solid absorbent. The gas that enters the absorber contains SO <sub>2</sub> among other things and it is this gas that mixes with the absorbent such that of the gas components, the SO <sub>2</sub> reacts with the absorbent in the presence of oxygen. There is a lack therefore of accuracy here.
Unit P					
1. Changes solids to powders. <i>Prestructural</i>	1. Misconception.			None.	Inaccurate.
Unit Q					

No function is given for this unit.					
<b>Unit N</b>					
<p>1. Absorbs heat.</p> <p>2. And increases the concentration of carbon monoxide and hydrogen gas to be processed thoroughly in the absorber.</p> <p>3. Chemical reactions three and four occur in this unit.</p> <p><i>Prestructural – it seems as if she looked at the reactions and the mass balance table given in isolation, and based on those decided what the function of this unit is.</i></p>	<p>1. Misconception.</p> <p>2. Misconception.</p>			Reactions 3 and 4.	<p>The unit does not absorb heat. It is not clear where the student thinks this heat is coming from.</p> <p>The function is not to increase the concentrations of the hydrogen and the carbon monoxide.</p> <p>Again, it's not clear where this idea came from. The student also calls this unit the absorber and talks about this unit thoroughly processing carbon monoxide and hydrogen. This is all highly inaccurate.</p> <p>Despite the above she gets the correct reactions.</p>
<b>Unit M</b>					
<p>1. Feeds the absorbent so that it extracts the gases in it.</p> <p>2. And the absorbent left inside is combined with another stream (13) to form stream 15.</p> <p><i>Unistructural - the problem word is extracts. There is evidence that she is seeing a separation happening somehow where the gas and the absorbent end up in different streams. However, the point is removing entrained absorbent from what is primarily a gas stream, as opposed to removing gas from absorbent. This is a subtle point.</i></p>	<p>1. Misconception.</p>		<p>2. Partial idea.</p>	None.	<p>Hard to understand. She says that the unit feeds the absorbent but does not say where it is being fed. She seems to think that the unit extracts the gases in the absorbent, and that whatever absorbent is left is combined with stream 13 to form stream 15. In any event she misses the primary function of this unit which is to separate entrained absorbent from the gas.</p>

**General comments**

There are 12 statements in total. 6 are misconceptions and 3 are partial ideas. The grammar errors make this rather difficult to decipher. The student struggles here and does not finish the question. There are a few strange ideas that she does not elaborate on and therefore gives no clues about what she may have been thinking. Even though there are no redundant statements, the number of misconceptions (50%) makes this response a prestructural response.

**7.4.7 Student G**

<b>Boiler</b>					<b>Comments</b>
<b>Response</b>	<b>Misconception</b>	<b>Redundant</b>	<b>Partial idea</b>	<b>Reactions</b>	
1. Responsible for burning coal <i>Unistructural – student makes only the one point and cites the wrong reaction.</i>				Reaction 2.	Not enough detail.
<b>Dust Extractor</b>					
1. Responsible for removing the dust from the SO <sub>2</sub> . <i>Prestructural – only one point made and it is not accurate.</i>	1. Misconception.				The unit removes dust from the entire gas stream and not just the SO <sub>2</sub> .
<b>Absorber</b>					
1. Responsible for allowing SO <sub>2</sub> and absorbent to react. 2. SO <sub>2</sub> is absorbed in this way. <i>Multistructural - two points that are valid but superficially connected.</i>				Reaction 1.	Some detail about the mechanism of absorption could have strengthened this response.
<b>Unit P</b>					
1. Responsible for solidifying sulphur. <i>Prestructural – only one point is made and it is not accurate. Student also then misses the reaction happening in this unit.</i>	1. Misconception.			None.	Not sure that the student examined the mass balance table at all here.
<b>Unit Q</b>					
1. Responsible for burning coal. <i>Prestructural – only one</i>	1. Misconception.			None.	Inaccurate.

<i>point is made and it is not accurate. Student also then misses the reaction happening in this unit.</i>					
<b>Unit N</b>					
1. Also responsible for allowing SO <sub>2</sub> and absorbent to react because the absorber is 100 efficient. <i>Prestructural – only one point is made and it is not accurate. Of the two reactions relevant to this unit, the student cites only one and another incorrect one.</i>	1. Misconception.			Reactions 4 and 1.	This is not accurate. He then chooses reaction 1 again as the other reaction in this unit.
<b>Unit M</b>					
1. Responsible for purifying the absorbent. <i>Unistructural</i>			1. Partial idea.	None.	This is very vague. Student needed to have elaborated on this.
<b>General comments</b>					
There are 8 statements in total. 4 are misconceptions and 1 is a partial idea. The student does not seem to have engaged much with this task. The responses are extremely brief and no attempt at elaboration is made. There also does not appear to have been any consulting of the mass balance table. Even though there are no redundant statements, the number of misconceptions (50%) makes this response a prestructural response.					

#### 7.4.8 Student H

<b>Boiler</b>					
<b>Response</b>	<b>Misconception</b>	<b>Redundant</b>	<b>Partial Idea</b>	<b>Reactions</b>	<b>Comments</b>
1. Coal and air and water are fed into the boiler. 2. Water is turned in the boiler into a steam which in turn steam is used for generator or turbines to move maybe. 3. The product that comes out of stream 6 is SO <sub>2</sub> with dust. <i>Unistructural – only one relevant point made and wrong reaction chosen.</i>		1. Redundant.		For this unit the student chooses a reaction that is not part of the list.	The student mentions two events, 1. and 2., in the boiler but does not connect them. This means that he does not know exactly what is happening in the boiler. Also the third point is worrying. The

					student identifies the exit stream as SO <sub>2</sub> and not flue gas containing SO <sub>2</sub> .
<b>Dust Extractor</b>					
1. Feed = stream 6, SO <sub>2</sub> with dust. Product = stream 8, dust and stream 7 without dust. 2. Dust extractor separates dust from SO <sub>2</sub> . <i>Prestructural – no relevant point made.</i>	2. Misconception.	1. Redundant.		None.	The unit removes dust from the entire gas stream and not just the SO <sub>2</sub> . And the feed is just stream 6, the gas, with dust. The SO <sub>2</sub> is part of the gas stream.
<b>Absorber</b>					
1. Feed = stream 10, SO <sub>2</sub> with hot air. 2. Product = stream 26, loaded absorbent and stream 13 hot air. 3. The absorber here with its particles that contain alkalised alumina absorbs SO <sub>2</sub> to form loaded absorbent in this way. (Writes down reaction 1). <i>Unistructural – the last point is closer to being true than the first two.</i>		1. and 2. are redundant.		Reaction 1.	Again the student separates the SO <sub>2</sub> from the gas. He mentions stream 10 as a separate stream but does not say whether it is a gas or not. Also the source of the hot air is unclear. The particles also do not contain alkalised alumina, they are alkalised alumina. The expression is awkward here.

<b>Unit P</b>					
<p>1. Unit P oxidises according to reaction 5.</p> <p>2. Unit P looks like a type 2 separator because it has one feed stream and two product streams. It converts a gas into two phases.</p> <p><i>Unistructural - one relevant point is made.</i></p>	<p>2. Misconception.</p>			<p>Reaction 2.</p>	<p>The student has latched onto an idea from a separate section. Type 2 separators often refer to phase separators such as condensers and evaporators. In cases where a reaction occurs, it isn't classified as a separator</p>
<b>Unit Q</b>					
<p>1. Looks like a recycle unit.</p> <p>2. Water here is taken back to the process.</p> <p>3. Feed streams are stream 25 and hot water.</p> <p>4. Products are streams 19.</p> <p>5. All the components are taken back for recycling.</p> <p><i>Prestructural – no relevant points are made here and the student misses the one relevant reaction.</i></p>		<p>All five statements are redundant.</p>		<p>None.</p>	<p>1. and 2. are not qualified and therefore it's not clear what the student refers to.</p> <p>3. and 4. do not add real value to the question.</p> <p>5. This is not accurate. It's not clear what components the student is referring to here.</p>
<b>Unit N</b>					
<p>1. They further oxidise the loaded absorbent to Sulphur as it leaves stream 18 to unit P where it is sold as sulphur powder.</p> <p><i>Prestructural – no relevant point is made here</i></p>	<p>1. Misconception.</p>			<p>Reactions 3 and 4.</p>	<p>The student has lumped units M and N here and declares them to both be</p>

					performing the function mentioned.
<b>Unit M</b>					
No function is given for this unit.				None	
<b>General comments</b>					
There are 16 statements in total. 3 are misconceptions and 9 are redundant. The student has mostly misinterpreted the flowsheet. He also does not appear to have looked and considered all the data given to address the problem. This is evidenced by omission of several reactions in some of his interpretations. There aren't that many misconceptions (19%). But the rest of this response is made up of statements that do not add value to the solution. The number of redundant statements (56%) makes this response a prestructural response.					

### 7.4.9 Student I

<b>Boiler</b>					
<b>Wrong/incomplete Ideas</b>	<b>Misconception</b>	<b>Redundant</b>	<b>Partial idea</b>	<b>Reactions</b>	
No solution has been provided for this unit					
<b>Dust Extractor</b>					
No solution has been provided for this unit.					<b>Comments</b>
<b>Absorber</b>					
1. The absorber removes all the solid particles which may occur in the stream and thus releasing only gases in stream 16. 2. The absorption process takes place by reaction 2. <i>Prestructural - no relevant points are made here and choice of reaction is wrong.</i>	1. Misconception. 2. Misconception.			Reaction 2.	He totally misses the function of the absorber. It's not clear what he is referring to when he talks about 'the stream' in the first point. The choice of reaction is wrong.
<b>Unit P</b>					
1. Responsible for solidifying sulphur. <i>Prestructural – one inaccurate idea here and student misses one reaction.</i>	1. Misconception.			None.	This is incorrect. Not sure that the student examined the mass balance table at all here.
<b>Unit Q</b>					
1. This reduces the water content of the stream by using	1. Misconception.			Reaction 2.	This is not incorrect but it is not to the point and

<p>it to oxidise CO to CO<sub>2</sub> according to reaction 2. <i>Prestructural - only one point made which is not entirely convincing.</i></p>					<p>does not give the essence of the unit. By virtue of the fact that the reaction is occurring where water is a reactant, it will get consumed, thus reducing its content. Therefore, the student could very well have said that the unit reduces the content of coal which would have been equally valid if just as weak.</p>
<b>Unit P</b>					
<p>1. In this unit carbon monoxide is oxidised to CO<sub>2</sub> and this results in the formation of a solid absorbent which is then removed by the absorbent through stream 20. 2. This happens through reaction 4. <i>Prestructural – no relevant points made and student misses a reaction.</i></p>	<p>1. Misconception.</p>	<p>2. Redundant.</p>		<p>The appropriate reactions here are reactions 3 and 4. The student mentions only reaction 4.</p>	<p>The oxidation of CO to CO<sub>2</sub> does not result in the formation of the absorbent. Then once formed the absorbent cannot be removed by the absorbent. It is not clear what the student was getting at here. It seems he has made the sole objective of the unit to oxidise the CO, with the incidental formation of the absorbent.</p>
<b>Unit M</b>					
<p>1. Unit M disposes the SO<sub>2</sub> free components from the incoming stream. 2. And the SO<sub>2</sub> containing components go to stream 14 for further processing. 3. This occurs by the reaction 5. 4. The water is disposed of while the sulphur goes through to stream 14 for further processing. <i>Prestructural – the first two points are contradictory and</i></p>	<p>1. Misconception. 5. Misconception. 4. Misconception.</p>		<p>2. Partial idea.</p>	<p>None.</p>	<p>No indication is made of what the SO<sub>2</sub> free components are that the unit disposes of. SO<sub>2</sub> components also end up in stream 14, which is definitely not a discard stream. Confusion here. The problem is that the student seems to think that this ‘disposal’ of the SO<sub>2</sub> components happens according to</p>

<i>the rest are not accurate.</i>					reaction 5. The problem with this is one of the reactants in reaction 5 is H <sub>2</sub> S, which does not appear anywhere before this unit. The student has therefore not looked carefully at the mass balance table.
<p><b>General Comments</b>  There are 10 statements in total. 8 of them are misconceptions, 1 is redundant and 1 is a partial idea. The student has not looked at all the data given and used it to inform him of what is taking place in the process. The misconceptions are 80% of the total number of statements. This response is therefore prestructural.</p>					

## 7.5 Discussion - Question 2

### Summary of the results

#### Stage 1

6 students of the 9 had problems with this stage. None of them calculated n using C4. 4 did not calculate n i.e. student A from the highest achieving group, students E and F from the intermediate group and student I from the weakest group. The two remaining students, students G and H are both from the weakest group and they assumed a value for n.

#### Stage 2

6 students of the 9 had problems with this stage. Of the 6, 4 did not use the data about 0.2 mole percent of SO<sub>2</sub> in the feed gas and as such used other means to the SO<sub>2</sub>. These are student A from the highest achieving group, Students E and F from the intermediate group and student I from the weakest group. The other two students, students G and H from the weakest group misinterpreted this piece of information and thus arrived at SO<sub>2</sub> using a different route. These are the same students who had problems with stage 1.

#### Stage 3

7 of the 9 students had problems with this stage. Of the 7, 4 did not use the data about the 92% removal of SO<sub>2</sub>. These are Students C of the highest achieving group, students D and F from the intermediate group and student H from the weak group. Students G and I from the weakest group and student E from the intermediate group misused the

information. They used it to effect invalid transformations and hence generated incorrect values of SO<sub>2</sub> reacted.

#### **Stage 4**

5 out of the 9 students had problems with this stage. None of them did this stage i.e. they did not link the SO<sub>2</sub> reacted to the amount of Sulphur produced using the reaction and stoichiometry. These are students E and F from the intermediate group, and students G and H from the weakest group and student C from the highest achieving group.

#### **Stage 5**

6 of the 9 had problems with this stage. Student C from the highest achieving group did not get this far in the problem. Students E and F from the intermediate group and student H from the weakest group used inappropriate conversion factors to transform the sulphur produced from one set of units (mole per second) to another set (mass per day). Students G and I from the weakest group did not convert their units.

Generally the errors that students made fall into four general categories. In the first category the errors are due to the use of invalid representations to transform given or appropriate content or data to new data. In the second category the errors are due to the use of invented data in valid representations. The transformations effected like in the first category are compromised. In the third category the errors are due to the use of incorrect data in invalid representations. In the final category the errors are due to data omission. Anyone of these is a content error that generates form that is different to the ideal task. All these types of errors result in the generation of incorrect data. The next section attempts to give explanations and make sense of these errors under the sections 'context' and 'transfer'.

#### **7.5.1 Context**

Context can be divided into three categories. First is the physical context of the problem. This refers to the background of the problem or the big picture that the students have to bear in mind as they deal with the subtask. This information applies to all the subtasks that form part of the big picture and the students are expected to extract from this pool whatever is relevant for the particular subtask. The second category under context is the subtask or the actual problem that the students have to attend to. The subtask has its own

information or data that needs to be combined with the data in the physical context. The final category is the student's own prior knowledge or knowledge system that they bring to the task. This comprises the procedures and the concepts and principles and the way in which these are structured. For this problem, the data that feeds into stage 1 is a combination of the student's knowledge and the data from the physical context. They are not told specifically to use C4 in this stage but the data given in the bigger context is such that C4 is the only option they have. Stage 3 is the only stage that is fed subtask specific information. The rest of the stages are fed physical context data available in different formats as well as outputs generated from previous stages.

### **Physical Context**

Only one student, student B the Chinese female student from the highest achieving group, used all relevant aspects of the data from the physical context. Of the eight, six used some aspects and two, students C from the highest achieving group and student F from the intermediate group, used none at all. In situations where the students did not know how to use the physical context data, they ignored it and invented their own. This happened mainly if the students had an idea of the nature of the desired output i.e. need the moles of the gas. Their strategy then involved manipulating the invented data using invalid representations to generate the desired content output. The desired output means that they have the moles of the gas but the actual value is incorrect. It stands to reason that if a representation is designed to transform a specific input (system property) into a specific output, then using invented input data in that representation requires that it be changed in order to get the desired output. This change automatically invalidates the representation. For students who did not know what the desired output needed to be, they used their invented input data in valid but irrelevant representations. These generated incorrect outputs. Yet other students used the correct inputs but because they did not know what the desired output needed to be, they used invalid or in some cases irrelevant representations.

### **Subtask Context**

Of the nine students, five used the one relevant piece of subtask data. Of the five, only two (students A and B from the highest achieving group) interpreted this data properly i.e. got the moles of SO<sub>2</sub> that react in the right units of measurement. The other three due to data invention or data omission in the physical context, misinterpreted the data such that the representations used in conjunction with this piece of data were either invalid or irrelevant. These were students E from the intermediate group, and students G and I from the weakest group. The other four seemed to ‘forget’ the problem and manipulated aspects of the physical context, which in any event generated invalid content and form.

### **Students’ prior knowledge systems as context**

This refers to the input of stage 1, C4 or  $PV = nRT$ . This was necessary to calculate the number of moles of the entire gas stream,  $n$ , of which SO<sub>2</sub> was part. Only four students of the nine managed to do this; all three students from the highest achieving group and students D from the intermediate group. This representation initiated the process but was not given. The students were expected to recognise that they needed to use it due to the given information in the physical context. The rest of the students invented data by assuming the moles or assuming densities or simply did not calculate the number of moles of the gas stream.

The students tended to use set procedures and rather changed the content given or concepts to suit their procedures. This was true even in cases that blatantly required that students review and change their procedures.

### **7.5.2 Transfer**

The biggest assumption about transfer is that the more general a rule or principle is the more applicable across situations it is. However in cases where there are a number of ways in which one property can be derived, then a particular rule runs the risk of being over generalised if the students’ web of related concepts is not big enough. The students tended to use a rule where the physical and subtask contexts did not in fact call for the use of that rule. They did not seem to have understood the general features of the situation that were relevant to the appropriate strategy. Hence the over-generalisation.

This question tested the students' grasp of principled knowledge as opposed to procedural knowledge. It also tested their use of declarative knowledge. Therefore content was key such that particular application of content dictated the form generated.

#### **7.6 Discussion – Question 4**

This question did not require the students to use any of the physical context data. Only the subtask and their prior knowledge systems were necessary for this question.

##### **Summary of the results**

###### **B1**

This stage required the given specific gravities for the three substances to be converted to densities. This did not have to be the first stage. Only one student, student B, converted all three substances. Five of the nine converted only two. Three converted none. The three are students C from the highest achieving group, student D from the intermediate group and student I from the weakest group.

###### **B2**

This stage required that students assume a basis for the mixture, either mass or volume, and then use it in B2 with the information from B1 (the density of the mixture) to get the mass or volume of the mixture. Again, this did not have to be stage 2. Only two students, students A and B managed to do all three. Some students assumed a mass/volume basis but used it incorrectly because they did not convert the mixture specific gravity to a density. Others had the mixture density but did not use it correctly because they did not have the mass or volume basis.

###### **B3 and B4**

These stages require the use of the densities of Na and Al from B1 to be transformed to masses or volumes (depending on whether a mass or volume basis was chosen). None of the students did this. Of the six who had worked out two of the three densities, three worked out the densities of the Na and Al, and two worked out the densities of the mixture and of Na. Of the former three two assumed a mixture basis. One of these and the third (who did not assume a mixture basis) converted their densities of Na and Al to masses by assuming individual volumes of Na and Al. The representations are valid but are not appropriate such that the transformations are not valid. The other student, despite

the mixture basis, had an elaborate procedure made up of invalid representations. The two students who worked out the densities of the mixture and of Na, simply divided the density of Na by the density of the mixture and declared this the solution. This is not a valid representation. The remaining student divided the specific gravity of Na by the specific gravity of the mixture. All the solutions ended here.

### **B5 to B8**

None of the students did these.

The students did not realise the importance of all three substances; hence only getting the densities of only two of the three. None of the students were able to link all three substances in one representation. Therefore all representations used only factored in two of the three substances. The representations are not invalid but the procedures are. The question did not require students to look at the physical context. The data came from the subtask in the way of the three specific gravities. The biggest problem seemed to be the inability of the students to take a representation and realise that it could be rearranged such that more information could be generated from it.

### **Subtask**

Seven of the nine students used the data from the subtask. None of these used the data in the appropriate way.

### **Students' prior knowledge as context**

All relevant links in the question relied on the students' prior knowledge. Since none of them used the subtask data appropriately none of them managed to use the correct procedures. They all knew what the desired outcome needed to be i.e. they knew they needed the mass of the mixture and that of Na. They introduced irrelevant data to get to these two values however. The transfer issue was really their failure to realise that the representation  $\frac{m}{v} = \rho$  referred to not only Na and Al individually but to the mixture also.

This representation, mass conservation i.e. mass of mixture = mass of Na + mass of Al (the same is true for volume) and the specific gravity representation i.e.

$$\frac{v_a}{\rho_w} = SGa$$

were the only representations necessary to solve the problem.

### **7.7 Discussion – Question 1**

The results for this question have been done slightly differently due to the nature of the question. Each of the different unit operations that the students were asked to describe will be discussed separately. The responses were analysed by looking at the number of statements made by the students per unit operation and deciding which of these were either misconceptions, redundant or vague statements that added no meaning to the solution or were partial understandings or incomplete ideas. The results of the analysis show that the total number of statements made by the students in answering the question was 128. Of this number, 74% (95) were problematic i.e. they were either misconceptions, redundant or partial understandings.

Most of the responses given were unistructural. This means there were a number of misconceptions and redundant statements. In some instances the grammar was a problem. Eight of the nine students are English second language speakers and for all of them at least one aspect of their response was compromised by the poor use of grammar. Further the students did not know how to use the physical context to put together a complete picture of the flowsheet.

Five of the nine students gave prestructural responses. These were all three students from the weakest group, student C from the highest achieving group and student F from the

intermediate group. Three students gave unistructural responses. These were students A and B and student D. Student E gave a multistructural response.

### **7.7.1 Misconceptions and redundant statements**

32% of all statements made were misconceptions. These were mostly bizarre ideas or ideas that had been learnt from a previous case study that students did not realise were not examples of general ideas but were specific to those situations. This is a case of over-generalisation.

27% of the statements were redundant. This is tantamount to tautology. These statements do not give new information about the unit processes. Students tend to do this when they have nothing else to write. They seem to believe that as long as they put 'something' down, even if it repeats the question or given obvious information, they will get credit.

## **7.8 Conclusion - Question 2**

### **7.8.1 The 'n' calculation – assimilation vs. accommodation**

The table shows that the first stage gives the most problems. 44 % of the students did not factor n, the number of moles of the feed gas, into their calculation. Interestingly enough they use C4 but incorrectly. The remaining students simply do not use C4 at all. It seems that as they start the problem, their main aim is to work out the SO<sub>2</sub> but forget that it is part of a stream that they would then first need to define. SO<sub>2</sub> is the end, but they do not see the means of getting to it i.e. the feed gas stream.

On the other hand, for those who do calculate n, they use the wrong representation to transform the input to n. The one method that is most familiar to students for calculating n is as follows;  $n = \text{mass of substance} / \text{molecular weight of substance}$  or  $(n = m/M)$ . C4 requires that they use a different method of arriving at n i.e.  $n = PV/RT$  (C4). The P,V,T and R, as given by the context, challenges their current structure of understanding the n calculation. As such they introduce their own data by way of m and M and revert to  $n = m/M$  which is comprised of simpler concepts than P, V, T and R, and is thus structurally

inferior to  $n = PV/RT$ . The reason is not that they are unfamiliar with C4, they have used it before, but because it was not written down on the question paper as an option and as such could not be perceived visually, it did not occur to them to use it.

C4 also seems to threaten their current understanding of the  $n$  calculation. The use of C4 would require that they extend or restructure their understanding of the  $n$  calculation to accommodate the new concepts of P,R and T. V they appear to be much more familiar with because even those who do not use C4 (and thus do not use P,T and R), managed to use V in a different representation. The students therefore seem not to have accommodated the familiar structure of C4 but rather assimilated it. Theory says that if they had accommodated the new structure, they would have been able to use it instead of reverting to the familiar less structurally complex version of calculating  $n$ . The end result is that they have not formed a structurally more complex web of concepts related to calculating  $n$ .

### **7.8.2 Data omission – the parts of the whole**

There are quite a few occasions of data omission. It seems that the students do not consciously see the problem as composed of different parts and as such, there is neither a mechanism nor motivation for them to check after each part to make sure that they are still in line with the objective of the whole. Hence, they leave out data that essentially differentiates the parts from each other.

### **7.8.3 Introduction of extra data – forgotten context**

One of the peculiarities about this problem is the constant need to refer to the bigger picture, the context as laid out, such that one does not lose themselves in the parts. This sounds ironic considering the earlier assertion that students need to see the different parts of the whole. Ironically, the students who divided the problem into different parts with each part using extraneous data, somehow kept referring to the context to try and get back on track. In other words, they knew they needed stage 1, i.e.  $n$ , but they used extraneous data coupled with their own representations to transform  $n$ ; or they knew that they needed  $SO_2$  in the feed stream i.e. transforming  $n$  to  $SO_2$ , but would then introduce new data to

do this. The bottom line of course is that what they put down on paper seems to reflect the confusion in their minds.

#### **7.8.4 Misinterpretation – the power of a bad representation**

Interestingly enough, or perhaps not, the two occasions of data misinterpretation corresponded to the instances of adding extra data and using different representations for the transformations. Due to the new representations introduced by the extra data added, the proper interpretations of given data could not work in the students' new representations. The students almost had to distort the data or evidence to suit their erroneous representations and transformations.

#### **7.9 Conclusion - Question 4**

In this problem, the students failed to manipulate a visually perceived representation due to the transfer issue highlighted earlier. They were not required to extend their knowledge by incorporating a new concept as much as they were required to extend the ways in which one concept can be used in one question or situation. They failed to see the same entity from several different angles to get different information from each angle.

None of the students realised that the mass of the mixture was the sum of the two constituents. In fact, the students do not seem to have visualised the absorbent particle as a mixture of  $\text{Na}_2\text{O}$  and  $\text{Al}_2\text{O}_3$ . They rather saw 'mixture' as a pile of these particles where some of them were pure  $\text{Na}_2\text{O}$  and the rest pure  $\text{Al}_2\text{O}_3$ . This is seen in the way that some of them assume a volume of  $\text{Na}_2\text{O}$  and of  $\text{Al}_2\text{O}_3$  separately and independently of the mixture and of the other constituent. All the responses tended to treat the mixture in this sense and the only differences were the repertoire of incorrect procedures they then came up with to get the mass of the mixture and the mass of the  $\text{Na}_2\text{O}$ .

The challenge in this type of abstract problem is not in the sense of being able to consider all resources available and seeing which areas of the situation are pertinent and being able to incorporate all data in the solution. Rather it is about being able to manipulate the one

piece of evidence or data provided i.e. the specific gravity data; to understand the attributes of the mass conservation law such a different reorganisation or variation of that structure does not amount to a different law.

## CHAPTER EIGHT

### 8. CONCLUSIONS

#### 8.1 Conclusions

To what extent has the case based approach afforded epistemological access to process engineering in first year? Out of the definitions of the case based approach that have emerged from the literature, two features stand out that set it apart from the traditional sort of problem. These are 'context' and 'active learning'. According to the claims found in the studies cited in the literature as well as the assumptions by the course designer of PRME1002, context-rich problems and active learning environments improve student thinking and problem solving skills and improve their attitudes and enjoyment of process engineering courses. It is also intended to introduce students to the 'way practitioners do engineering' so to speak. It was noted in chapter three that while the literature has shown that the case based approach or broadly speaking the co-operative and active learning approach improved the affective and attitudinal factors, no substantive account of the nature of the improvement in student thinking and problem solving has been given.

What are the inherent functional demands of a context rich problem? According to Dewey (1938) context is about the experience of objects or events as connected to a contextual whole. In this sense, the students have to be aware and operate at an integrated level, merging the salient aspects of the context and their structures of knowledge and bringing these to bear on the problem or subtask. The context rich problem assumes that the way in which the problem is framed will send signals to the students of the nature of the problem and appropriate strategies. Immediately this creates a problem. The case based approach was introduced by the course designer to, among other things, teach students to think in integrated ways. This is tantamount to taking a student who does not yet possess a certain skill, and putting them in a situation that requires that they use the skill they do not yet have!

The trouble with this is that it has as much chance of succeeding as failing. It succeeds if a student considers the contextualised problem as unfamiliar or as presenting a contradiction to what they know, and reconstructs or restructures their knowledge accordingly to compensate for the unfamiliarity or contradiction. In this way, they gain access to new knowledge and new ways of thinking. If however the student, much like the student responses from the sample revealed, recognises the contradiction but ignores it, invents evidence and representations and does not reconstruct or restructure, the context in this sense has not afforded these students access to new knowledge, new understanding and new ways of thinking. This is not an indictment against the issue of context or the idea of a case based approach but a commentary on the demands placed on the student's fundamental functioning that need to be addressed prior to introduction of such innovations. Otherwise the innovations may not afford access to knowledge.

Of interest here is that even students who come from traditionally advantaged backgrounds do not necessarily reconstruct and restructure. Miller (1989) argues that people construct knowledge in solitude i.e. after actual teaching has happened. For students to be able to solve new problems on their own requires that they self regulate and direct their actions in various ways. The advantaged students are supposed to have been prepared better for the processes of self-regulation.

The above referred mostly to the evidenced inability on the students' part to work with principled knowledge. The questions given, i.e. questions 2 and 4 were not algorithmic, but required students' heuristics to operate. The heuristics in this sense are the students' knowledge that would help them to recognise promising approaches to problems. If the heuristics were useful the students would know that the design of the context in terms of declarative knowledge implies a certain solution strategy. But if their knowledge of the basic principles, as captured by both the separate structures of content and procedures, is not strong the heuristics will not be useful. If this is not addressed, context rich problems become overwhelming to students that they deny access to the goods of the discipline.

Question 1, the flowsheet interpretation exercise, presented problems to students of a different nature. This type of problem was an attempt at fulfilling yet another of the course designer's assumptions about case based approach i.e. that they introduce students to the ordinary activities of the practitioners. By implication therefore, engineers interpret flowsheets. However, the big difference is that the content i.e. the different unit processes (the boiler, the absorber, the separator etc.), are familiar to these engineers. They work with these on a daily basis. The problem for them, at the risk of sounding simplistic, then becomes deciphering the new arrangement of the unit processes and the dynamics that each new arrangement creates.

For the students, the content is not familiar. They are being asked to decipher the dynamics of an arrangement of the unit processes with very little knowledge of the unit processes themselves. Hence the misconceptions, the redundant statements, the imposition of previously learnt flowsheet interpretation results to the new one and the lack of connectivity. Their responses were unlikely to reach the relational level by SOLO standards. This would be fine as a class learning exercise, where nothing much depended (in terms of marks) on the students' responses. However, this was an examination question, where they were failed (or passed) depending on their responses. Again here then, the context did not help the flowsheet interpretation exercise due to the lack of disciplinary knowledge on the part of the students.

For students who through their upbringing have gained intuitive knowledge of these processes, or for students who have obtained other degrees prior to doing first year process engineering, this exercise does not pose a particular problem. In this sense however differential access has been created where some students have access to the knowledge because culturally the constructs or aspects introduced by the case studies are not completely unfamiliar to them.

All efforts that attempt to engage the student actively in the learning process are applauded. However all such attempts cannot and should not go ahead of the student. Otherwise they run the risk of being innovations and instructional designs with no real

evidence of improved performance on the part of the student. Further the entailments of the efforts need to be understood by the educator and certain key potential problems anticipated before the innovations are implemented. Otherwise students are perpetually caught and carried in the educator's stream of new ideas and innovations where they do not benefit and never know whether they have learnt successfully or not. Careful attention must be given to the design of these such that they don't inadvertently create differential access to the knowledge because of the assumptions made.

## CHAPTER NINE

### *9. LIMITATIONS OF THE STUDY*

This study has a potential validity threat of the following nature. Several useful ways could add more to this study. Firstly it was mentioned in chapter three that there are different ways of developing a case study. Therefore a different application of the case based approach could lead to different findings. Secondly a sample that includes a wider range of stronger and weaker students could lead to different findings.

In their design on the SOLO taxonomy Biggs and Collis defended their focus on the response of the individual as opposed to the individual by citing research findings alluding to the fact that students perform a task better today that they perform poorly on a different day. One way in which it could be ascertained whether in fact students are able to function in the required manner could be to interview them on their responses with no time constraints or threat of a poor grade. This would give a better indication of the way in which they work with what they know.

Lastly it would have been useful to capture the group interactions. This would give insight into the way that the students actually deal with the work in class where they have all the opportunity to interrogate the teaching staff members who are present to clear up any confusion or misconceptions. This is of paramount importance as issues of epistemological access are also a function of the student. If students are not able to manage group work effectively, this may have detrimental effects on their overall progress in the course.

## REFERENCES

- Armstrong, E. (2004). 'Case-based teaching' in *Providing Case-based Teaching to Paediatric Training Programs Worldwide*. Available from: <<http://www.pedicases.org/teaching/overview/back.html>> 18/04/2006.
- Anderson, J. R., Reder, L.M. and Simon, H.A. (1996). Cited in Cobb, P. and Bowers, J. (1998). 'Cognitive and situated learning: perspectives in theory and practice'. In *Educational researcher*. 28(2). pp. 4-15.
- Bailey, T. (1993). Cited in Kirshner, D. and Whitson, J.A. (1997). 'Editor's introduction to situated cognition'. In *situated cognition: social, semiotic, and psychological perspectives*. (eds) D. Kirshner and J.A. Whitson. Mahwah, NJ: Lawrence Erlbaum Associate. pp. 4-13.
- Bak, N. (1998). 'Organising learning in large group teaching'. In *Vision and reality: changing education and training in South Africa*. (eds) W. Morrow and K King. UCT Press. pp. 204-212.
- Barab, S.A. and Hay, E.K. (2001). 'Doing Science at the Elbows of Experts: Issues Related to the Science Apprenticeship Camp'. In *Journal of Research in Science Teaching*. John Wiley and Sons. 38(1). pp. 70-102.
- Barnes, L.B., Christenssen, C.R. and Hansen, A. (1994). Cited in Raju, P.K. (1999). 'Teaching real world issues through case studies'. In *Journal of Engineering Education*. 88(4).pp. 501-508.
- Bell, P.C and von Lanzenauer, C.H., (2000). Cited in Jerrard, M. A. (2005). 'Assessing student learning and skills using the case study method'. In *Journal of new business ideas and trends*. 3(1). pp. 27-36.

Bennet, S., Harper, B. and Hedberg, J., (2002). Cited in Jerrard, M. A. (2005). 'Assessing student learning and skills using the case study method'. In *Journal of new business ideas and trends*. 3(1). pp. 27-36.

Bereiter, C. and Scardamalia, M. (1989). Cited in Bereiter, C. (1997). 'Cognition, context, and learning: A social semiotic perspective'. In *Situated cognition: Social, semiotic, and psychological perspectives*. (eds) D. Kirshner and J. A. Whitson. Mahwah, NJ: Lawrence Erlbaum Associate. pp. 37–56.

Bereiter, C. (1997). 'Cognition, context, and learning: A social semiotic perspective'. In *Situated cognition: Social, semiotic, and psychological perspectives*. (eds) D. Kirshner and J. A. Whitson. Mahwah, NJ: Lawrence Erlbaum Associate. pp. 37–56.

Biggs, J.B. and Collis, K.F. (1982). *Evaluating the quality of Learning: The SOLO Taxonomy*. Academic Press. chapters 1 and 2.

Bonoma, T.V. (1989). Cited in Jerrard, M. A. (2005). 'Assessing student learning and skills using the case study method'. In *Journal of new business ideas and trends*. 3(1). pp. 27-36.

Bransford, J.D. and Schwartz, D.L. (1999). 'Rethinking Transfer: A simple proposal for Multiple Implications'. In *Review of Research in Education*. (eds) Carl Bereiter and Rand Spiro. 24. Chapter 3.

Broudy, H. S. (1977). Cited in Bransford, J.D. and Schwartz, D.L. (1999). 'Rethinking Transfer: A simple proposal for Multiple Implications'. In *Review of Research in Education*. (eds) Carl Bereiter and Rand Spiro. 24. Chapter 3.

Bruner, J. (1966). Cited in Smith, M.K. (2002). 'Jerome S. Bruner and the Process of Education'. In *The Encyclopedia of Informal Education*. <http://www.infed.org/thinkers/bruner.htm>.

Craig, A. (1996). 'Education for All'. In *South African Journal of Higher Education*. 10(2). pp. 47-55.

Cobb, P. and Bowers, J. (1998). 'Cognitive and situated learning: perspectives in theory and practice'. In *Educational researcher*. 28(2). pp. 4-15.

Davis, A., (1995). 'Criterion Referenced Assessment and the development of knowledge and understanding'. In *Journal of Philosophy in Education*. 29(1). pp. 3-22.

Davis, C. and Wilcock, E. (2004). 'Case study teaching'. In *Effective Teaching and Learning in Engineering*. (eds) Caroline Baillie and Ivan Moore. Routledge-Farmer. pp. 51-68.

Detterman, D. L. and Sternberg, R.J. (1993). Cited in Bransford, J.D. and Schwartz, D.L. (1999). 'Rethinking Transfer: A simple proposal for Multiple Implications'. In *Review of Research in Education*. (eds) Carl Bereiter and Rand Spiro. 24. Chapter 3.

Dewey, J. (1938). Cited in Engeström, Y. and Cole, M. (1997). 'Situated cognition in search of an agenda'. In *Situated cognition: Social, semiotic, and psychological perspectives*. (eds) D. Kirshner and J. A. Whitson. Mahwah, NJ: Lawrence Erlbaum Associates. pp. 301-309.

Duguid, P., Collins, A. and Brown, J.S. (1989). 'Situated Cognition and the Culture of Learning'. In *Educational Researcher*. 18(1). pp. 32-42.

Engineering standards generating body. 2002. Project 3. Draft whole qualification standard for the national diploma in engineering.

Ertmer, P.A. and Russel, J.D. (1995). Cited in Jerrard, M. A. (2005). 'Assessing student learning and skills using the case study method'. In *Journal of new business ideas and trends*. 3(1). pp. 27-36.

Felder, M.R. (1995). 'A Longitudinal Study of Engineering Student Performance and Retention IV: Instructional Methods and Student Responses to them'. In *Journal of Engineering Education*. 84(4). pp. 361-367.

Fry, H., Ketteridge, S. and Marshall, S. (1999). Cited in Davis, C. and Wilcock, E. (2004). 'Case study teaching'. In *Effective Teaching and Learning in Engineering*. (eds) Caroline Baillie and Ivan Moore. Routledge-Farmer. pp. 51-68.

Gopinath, C. (2004). Cited in Jerrard, M. A. (2005). 'Assessing student learning and skills using the case study method'. In *Journal of new business ideas and trends*. 3(1). pp. 27-36.

Grant, R., (1997). Cited in Jerrard, M. A. (2005). 'Assessing student learning and skills using the case study method'. In *Journal of new business ideas and trends*. 3(1). pp. 27-36.

Greeno, J.G., Collins, A.M. and Resnick, L.B. (1996). 'Cognition and Learning'. In *Handbook of Educational Psychology*. (eds) D. Berliner and R. Calfee. Macmillan: New York. pp. 15-46.

Henning, L. (2005). *Using phenomenography to explore the relationship between students' perceptions of the learning context of their first year engineering course and their approaches to learning*. Masters thesis. University of the Witwatersrand. Unpublished.

Jerrard, M. A. (2005). 'Assessing student learning and skills using the case study method'. *Journal of new business ideas and trends*. 3(1). pp. 27-36.

Johnston, S., Lee, A. and McGregor, H. (1996). 'Engineering as captive discourse'. In *Techné: Journal of the Society for Philosophy and Technology*. 1(3-4). Available from <<http://scholar.lib.vt.edu/ejournals/SPT/v1n3n4/>>

Kirshner, D. and Whitson, J.A. (1997). 'Editor's introduction to situated cognition'. In *Situated cognition: Social, semiotic, and psychological perspectives*. (eds) D. Kirshner and J.A. Whitson. Mahwah, NJ: Lawrence Erlbaum Associates. pp. 4-13.

Kunselman, J.C. and Johnson, K.A. (2004). Cited in Jerrard, M. A. (2005). 'Assessing student learning and skills using the case study method'. In *Journal of new business ideas and trends*. 3(1). pp. 27-36.

Kvale, S., (1995). Cited in Kirshner, D. and Whitson, J.A. (1997). 'Editor's introduction to situated cognition'. In *Situated cognition: Social, semiotic, and psychological perspectives*. (eds) D. Kirshner and J.A. Whitson. Mahwah, NJ: Lawrence Erlbaum Associates. pp. 4-13.

Lave, J. (1988). Cited in Cobb, P. and Bowers, J. (1998). 'Cognitive and situated learning: perspectives in theory and practice'. In *Educational researcher*. 28(2). pp. 4-15.

Lave, J. and Wenger, E. (1991). Cited in Kirshner, D. and Whitson, J.A. (1997). 'Editor's introduction to situated cognition'. In *Situated cognition: Social, semiotic, and psychological perspectives*. (eds) D. Kirshner and J.A. Whitson. Mahwah, NJ: Lawrence Erlbaum Associates. pp. 4-13.

Lave, J. (1993). 'Situating learning in communities of practice'. In *Perspectives on socially shared cognition*. (eds) L. B. Resnick, J. M. Levine, and S. D. Teasley. Washington DC: American Psychological Association. pp. 17-36.

Lave, J. (1997). 'The culture of acquisition and the practice of understanding'. In *Situated cognition: Social, semiotic, and psychological perspectives*. (eds) D. Kirshner and J. A. Whitson. Mahwah, NJ: Lawrence Erlbaum Associates. pp. 17-34.

Lemke, J. (1997). 'Cognition, context, and learning: A social semiotic perspective' In *Situated cognition: Social, semiotic, and psychological perspectives*. (eds) D. Kirshner and J. A. Whitson. Mahwah, NJ: Lawrence Erlbaum Associates. pp. 37-56.

Miller, R. (1989). 'Conceptual Issues on Theorising about Cognition'. In *South African Journal of Higher Education*. 3(1). pp. 154-159.

Moore, A. (2001). 'Models of Teaching and Learning'. In *Teaching and Learning: Pedagogy, Curriculum and Culture*. Routledge (UK). Chapter 1.

Mourtos, N. J. and Furnam, B.J. (2002). 'Assessing the Effectiveness of an Introductory Engineering Course for Freshman'. *32<sup>nd</sup> AIEE/IEEE Frontiers in Education Conference*. Boston Massachusetts.

Newell, A. (1980). Cited in Greeno, J.G. Collins, A.M. and Resnick, L.B. (1996). 'Cognition and Learning'. In *Handbook of Educational Psychology*. (eds) D. Berliner and R. Calfee. Macmillan: New York. pp. 15-46.

Piaget, J. (1970). Cited in Fischer, K.W. and Bidell, T.R. (2005, in press). 'Dynamic development of action, thought and emotion'. In *Theoretical models of human development*. (ed) R.M. Lerner 6(1). New York:Wiley. pp. 2-10.

Raju, P.K. (1999). 'Teaching real world issues through case studies'. In *Journal of Engineering Education*. 88(4). pp. 501-508.

Robinson, J.A. (1998). 'Engineering thinking and rhetoric'. In *Journal of Engineering Education*. 87(8). pp. 227-229.

Rogoff, B. (1995). Cited in Cobb, P. and Bowers, J. (1998). 'Cognitive and situated learning: perspectives in theory and practice'. In *Educational researcher*. 28(2). pp. 4-15.

Rowell, J.A. (2000). 'Piagetian Epistemology: Equilibration and the Teaching of Science'. In *Reader: Learning and Teaching*. Faculty of Education Wits University. pp. 301-318.

Salomon, G. and Perkins, D.N. (1989). 'Rocky Roads to Transfer: Rethinking Mechanisms of a neglected phenomenon'. In *Educational Psychologist*. Lawrence Erlbaum Associates Inc. 24(2). pp. 113-142.

Sfard, A. (1998). 'On two Metaphors for learning and the dangers of choosing just one'. In *Educational Researcher*. 27(2). pp. 4-13.

Shalem, Y. and Slonimsky, L. (2004). 'Pedagogic Responsiveness for Academic Depth'. In *Curriculum Responsiveness: Case Studies in Higher Education*. (ed) Hanlie Greisel. SAUVCA. pp. 81-100.

Shaw, M.C. (2001). 'What engineers do'. In *Engineering Problem Solving: A Classical Perspective*. William Andrew Inc. pp. 1-10.

Skemp, R.R. (1971). *The Psychology of Learning Mathematics*. Penguin. Chapters 1 and 2.

Strohm-Kitchener, K. (1983). 'Cognition, Metacognition and Epistemic cognition'. In *Human Development*. 26. pp. 222-232.

Theroux, J. and Kilbane, C. (2004). Cited in Jerrard, M. A. (2005). 'Assessing student learning and skills using the case study method'. In *Journal of new business ideas and trends*. 3(1). pp. 27-36.

Tonso, K. A. (1996b). Cited in Godfrey, E. J. (2003). *The culture of engineering education and its interaction with gender: a case study of a New Zealand university*. A

thesis submitted for the degree of Doctor of philosophy. Curtin University of Technology.

Wenger, E. (1998). *Communities of practice: learning, meaning and identity*. Cambridge university press: New York. Chapters 1, 2, 3 and 6.

Wertsch, J.V. (1991). In Shalem, Y. and Slonimsky, L. (2004). 'Pedagogic Responsiveness for Academic Depth'. In *Curriculum Responsiveness: Case Studies in Higher Education*. (ed) Hanlie Greisel. SAUVCA. pp. 81-100.

Woollacott, L.C. and Snell, D. (2004). 'A Reconceptualisation of Engineering Education based on Situated Learning Theory'. Unpublished.

Wollacott, L C. and Henning, L. (2004). 'Dealing with underpreparedness in engineering entrants: a perspective from wits'. In *For engineering educators*. (ed) D. Fraser. 8(1). pp. 3-8.



## APPENDIX 2

### **PRME1002: INTRODUCTION TO PROCESS and MATERIALS ENGINEERING**

#### **THURSDAY 1Q2bT – 24<sup>th</sup> Feb, 2005: CASE STUDY 1**

##### **Learning Outcomes:**

*The general learning outcomes for this course were indicated at the beginning of the course. The specific learning outcomes for this case study have to do with the following:-*

- **General Processing Knowledge: Raw Materials handling (of solids)**
- **Engineering Practice: Conceptual design and elementary costing**
- **Technical Concepts: Mass/volume relationships.**

##### **Instructions:**

- Read through the case study description and make sure you understand what is required.*
- Do the work as instructed. (Note: you will receive further guidance as you go.)*
- Write down any questions your group asks or wants to ask?*
- Where insufficient information is available, make appropriate assumptions and record the assumptions you make.*
- At the end of the session, write a brief 'work memo' explaining and justifying your findings and any recommendations you make.*

### **CASE STUDY 1: "PLANT ON A BARGE"**

You are a process engineer and part of an engineering design team. The company you work for plans to exploit a large number of small ore deposits found along a large tributary of a river. The plan is to buy a barge and modify an existing processing plant so that it can be fitted into and operate on the barge. This 'plant on a barge' will then be floated down the river from deposit to deposit. The idea is to get the ore from the river bank, then use the plant on the barge to prepare the ore for transportation and transfer it to transporters (smaller barges) that will carry the ore to a metallurgical plant at the river mouth.

Your company has asked your team to do a number of investigations to check the feasibility of this plan before they go any further. The details of the investigations required will be given to you from week to week.

#### **INVESTIGATION 1.1:**

Decide whether or not the barge needs to be modified and if so design the modification needed.

##### **Available Information**

###### 1) Barge Details

- Mass: 420 tonnes (1 tonne = 1 000 kg)
- Cross sectional dimensions: The barge is rectangular with dimensions 10 x 30 m.
- Height of sides = 2 m.
- Thickness of steel sides of the barge = 0.75 inch. SG of steel = 7.9.

###### 2) Plant Details

- Estimated mass of the existing plant (after modification) = 250 tonnes.

- Length of conveyor belts in the plant is 125 feet. Assume that 80% of this length is covered with ore during normal operations and that the cross-section of ore on a belt is triangular. Width of ore bed on the belt is about 50 cm and the depth is about 10 cm.
- Estimated mass of ore in the plant equipment during normal operations = 50 tons (excluding ore on conveyors).
- Expected ore processing rate = 100 tonnes/hr.

3) Ore Details

- The SG of the ore material is about 3.4.
- The bulk density of the ore in its lumpy condition is estimated from a mining manual to be about 125 lb/ft<sup>3</sup>. (The bulk density takes into account the volume of air between the lumps of the ore.  
Bulk density = heap mass/heap volume)

4) Other Details

- 14 people are required to keep the plant operating 12 hours per day.
- Three cylindrical fuel tanks (3m x 3m) must be installed on the barge for the barge engines and for generating electricity. The density of the fuel is 50 lb/ ft<sup>3</sup>.

5) Conversion Factors

1 lb = 0.435 kg;    12 in = 12 inches = 1 foot = 0.32 m;            1 tonne = 1 000 kg

### **INVESTIGATION 1.2**

The idea is to get the ore from the river bank into transporters (smaller barges) that will carry the ore to a metallurgical plant at the river mouth. Think about what is needed to do this job. In particular, think carefully about the nature of the ore being processed and how this might affect the way it is processed. Make a list of the equipment that you think must be on the barge to do the job. Make a simple drawing of how the processing plant on the barge should be arranged.

At an appropriate time you will be given information on the processing equipment needed for this plant.

### **Information for Investigation 1.2**

#### **Conventional Screening**

The basic operation of a screen is very simple, as shown in the figure. The particles to be separated are fed to the screen at one end and are made to move across a surface that is perforated. Particles falling through the surface are collected in the sloping underpan and are removed as the undersize stream. Particles that do not fall through the surface are discharged as the oversize stream from the end of the screen opposite to the feed end. Whether a particle passes through the apertures of the screening surface to the undersize product will depend on its size and shape. Very large particles have zero probability of reporting to the undersize, whereas very small particles have a very high probability of doing so.

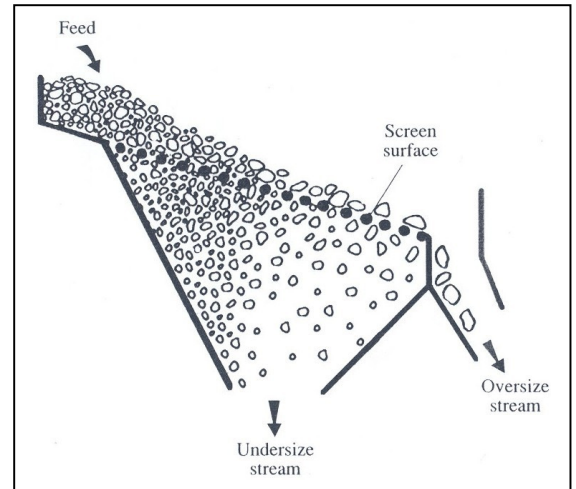

#### **Stationary Screens: Grizzlies**

Stationary screens are employed for the rough screening of coarse material and are termed grizzlies. They are usually inclined so that the relative movement between the screening surface and the material being treated is achieved as the material falls onto the surface and slides down. The screen surface is made up of heavy, robust bars set in a frame parallel to and inclined in the direction of material flow. In some applications improved operation and separation performance is obtained by using grizzlies set in a vibrating frame.

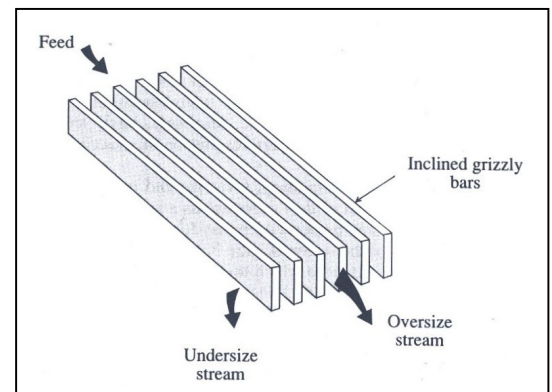

#### **“Moving-frame” Screens**

In these devices, the perforated surface is set in a frame that is agitated vigorously. One, two, or three screening surfaces may be set into a single frame in single-, double-, or triple-deck configurations. The rapid relative movement engineered between the particles and the screening surface facilitates rapid rates of screening. Not only does it increase the number of times a given particle on the screen surface is presented to an aperture, but it also increases the movement of particles down through the bed to the surface of the screen.

The movement of the frame can be designed to facilitate the translation of the material bed along the screen. Because this translational action can be very strong, it is possible for the screening surfaces to be horizontal or even inclined against the direction of material flow. Very often, however, the frame is inclined in the direction of material flow so as to increase the speed of travel of the bed down the length of the screen. This increases the screening capacity, but reduces the

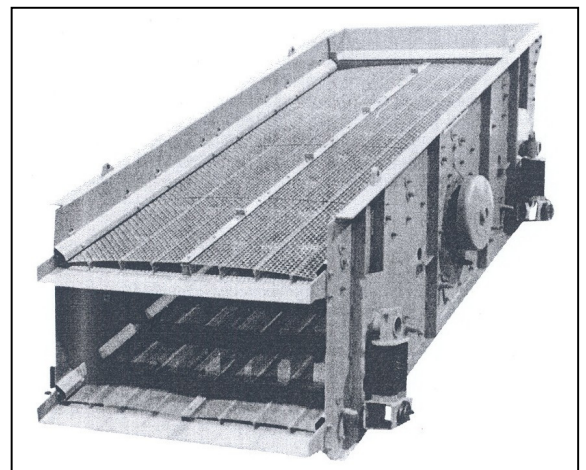

screening efficiency because particles spend less time on the screen.

There are a variety of ways to impart vigorous movement to a screen surface. With a **vibrating screen** (see figure), the most widely used screen in minerals engineering, the drive used is either electro-mechanical or a system of rotating weights that are out of balance. Other types of screen take their name from the type of motion that is imparted to the screen surface. Examples include reciprocating, oscillating, shaking, and gyrating screens.

Vibrating Screen (Double deck)

### General Aspects of Crushing

Large forces are needed to break rocky material, and these must be applied through the moving parts of a crusher. The crushing environment from a mechanical point of view is therefore very rugged. The machines must be structurally massive and robust. Tough, wear-resistant steel liners must be used for all crushing surfaces to reduce wear rates. In addition, mechanical breakdowns are fairly common, and routine maintenance must be regular and extensive. The operating costs of a crusher installation are therefore high.

### Types of Crushers

In general, a crusher consists of a crushing chamber in which compressive or impactive forces are brought to bear on the material to be broken. This material, which must be dry or have a low moisture content, is introduced through a feed which must be dry or have a low moisture content, is introduced through a feed opening, falls into a crushing chamber, is broken, and then falls out through a discharge opening. The breakage forces are applied through crushing surfaces, which may be either stationary or moving in a rigidly constrained path.

In compression crushers, compressive forces are applied as material is gripped between two surfaces that move towards each other. In jaw crushers, one surface is stationary and the second oscillates between two extreme positions, (Figure a) As the second surface moves towards the stationary surface, oversize particles are caught and broken. Fragments of breakage remain in the crushing chamber until they are sufficiently small to fall through the gap between the two surfaces.

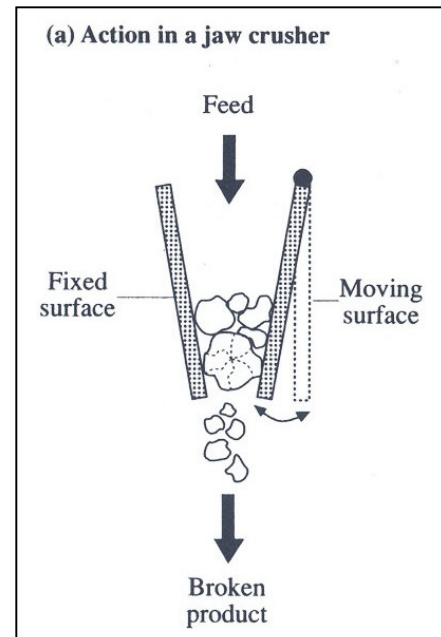

In roll crushers, one or more cylindrical rolls rotate about their longitudinal axes and draw material into the breakage zone. Provided that the particles are not too large, they will be gripped and compressive forces will be applied as the rolls rotate towards one another, (Figure b). Fragments will remain between the rolls until they are small enough to fall through the gap between them. Because of this, the top size of the product from a roll-crusher is closely controlled by the gap between the rolls. A similar type of control is exerted by jaw- and gyratory-type crushers, though in their case the oscillating motion of one of the crushing surfaces makes the control less precise.

In crushers designed to use impactive forces for comminution, breakage is achieved when particles impact against one or more surfaces. The crushing action may be engineered by rapid rotation of one or more crushing surfaces in a circular path, (Figure c). In the latter case, the material drops into the breakage zone and is struck repeatedly as long as it remains in the crushing chamber. There is, however, no inherent control of the top size of the crusher product as in compressive crushers. For this reason, impact crushers are sometimes fitted with a grid across the discharge opening to control the top size of the product.

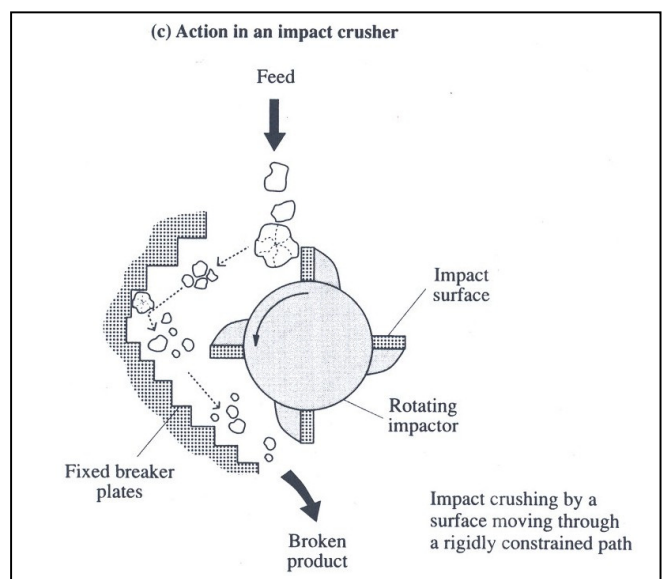
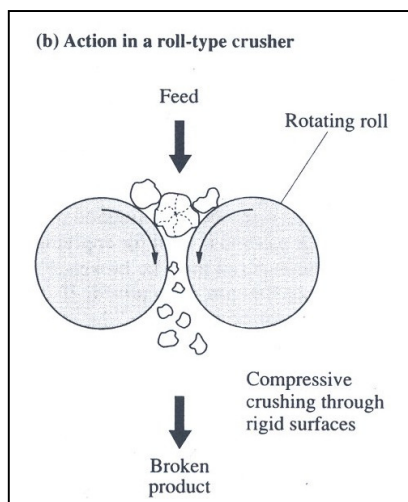

### INVESTIGATION 1.3

Your company has abandoned the idea of using an existing plant in the barge and now plans to build a new plant. From the last investigation, (investigation 1.2) the flow sheet below has been accepted by your company as the 'bare-bones' of this new plant. You are required to calculate a rough estimate of the cost of such a plant. To do this you first need to produce a rough 'plant layout' – a sketch of how the equipment will be 'laid out' (arranged). You are given the following information, assumptions and guidance:

#### Information Provided

##### Rough Equipment Dimensions

- Jaw Crusher: 1.2 m high, 0.6 m square, crusher opening (0.6 x 0.25 m)
- Screen: 1.3 m wide, 2 m long, 0.85 m high. A 'flat' as opposed to an inclined screen is to be used.
- Conveyors: 300 mm wide. The maximum allowed angle of inclination = 20°.

##### Lay Out Guidelines

- Space must be provided around each item of equipment for safe operation and for access for maintaining and checking the equipment. Allow 1 m around conveyors and screens and 2 m around crushers.
- Allow a drop of 1 m from the end of a conveyor onto the equipment it feeds, 0.5 m from the bottom of the crusher onto the conveyor it feeds. For the screen, allow 0.8 m drop for the coarse material and 1.2 for the "fine" material.
- Design the conveyors to be at least 1 m above ground or floor level.
- Assume the layout of all other items on the barge will be sorted out after the plant has been laid out.

##### Flow Sheet

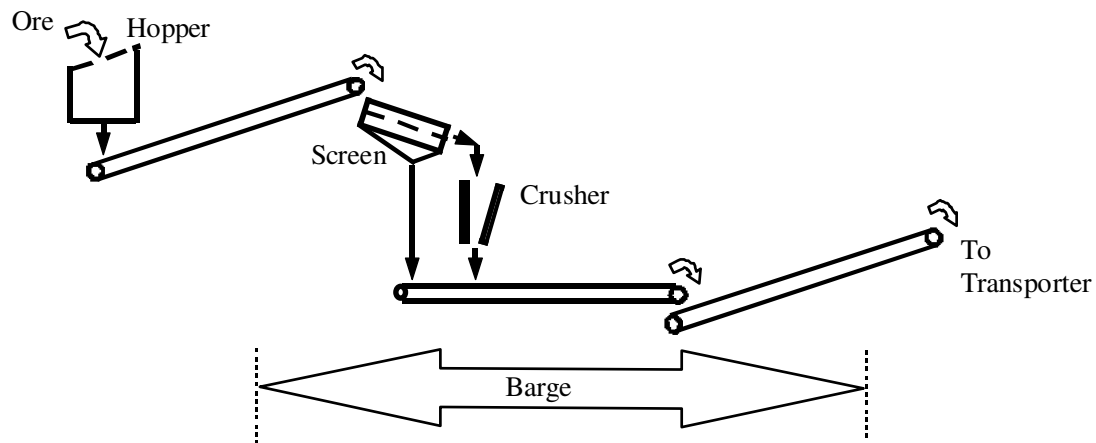

## PRICES OF EQUIPMENT

These prices are only an estimate and relate to September 1988

Description	Price Power	a	b	c	Size/ Capacity	Range
<b>Bins, mild steel, installed</b>	R,000's	7,557+00	6,663-01	2,743-03	Heaped capacity m <sup>3</sup>	10-80
Conveyors, belt:					Length m	5-400
Width 450mm	R,000's	1,293+01	1,600+00	0,000+00		
Width 600mm	R,000's	1,496+01	1,763+00	0,000+00		
Width 750mm	R,000's	1,663+01	1,980+00	0,000+00		
Width 900mm	R,000's	2,045+01	2,142+00	0,000+00		
Width 1050mm	R,000's	2,510+01	2,279+00	0,000+00		
Width 1200mm	R,000's	2,934+01	2,454+00	0,000+00		
<b>Crushers, jaw</b>	R,000's	9,531+00	1,447+02	8,881+01	Dimensions of opening m <sup>2</sup>	0,10-1,95
	kW	-1,120+00	1,608+02	-1,750+01		
<b>Screens, vibrating, horizontal, single-deck</b>	R,000's	2,816+01	5,235-01	2,917-01	Area m <sup>2</sup>	1,5-15
	kW	7,044+00	-4,649-02	1,104-01		
<b>Screens, vibrating, horizontal, double-deck</b>	R,000's	3,766+01	7,908-02	4,504-01	Area m <sup>2</sup>	1,5-15
	kW	9,247+00	-7,362-01	2,640-01		
<b>Screens, vibrating, inclined, single-deck</b>	R,000's	8,924+00	2,688+00	9,533-02	Area m <sup>2</sup>	2-13
	kW	5,244-01	7,914-01	1,127-01		
<b>Screens, vibrating, inclined, double-deck</b>	R,000's	1,015+01	2,909+00	8,978-02	Area m <sup>2</sup>	2-13
	kW	5,244-01	7,914-01	1,127-01		

Notes: (a) The equations are quadratic and in the form  $y = a + bx + cx^2$

Where  $y$  = cost or power consumption

$x$  = size or capacity

$a, b, c$  = constant/coefficients that are listed in the table.

For example, to price a 50m<sup>3</sup> mild-steel bin, the calculation is as follows, the values for  $a$ ,  $b$  and  $c$  being taken from the first item above:

$$7,557 + 0,6663 (50) + 0,002743 (50^2) = R47\ 7430.$$

**TABLE 1: PLANT COST INDEX (1984 – 1989)**

(Reference for the equipment selection and power information: 'Handbook on Estimation of Metallurgical Process Costs', W Ruhmer, Mintek Special Publication No 14, 1991)

Quarter	Index	Quarter	Index
Sep. 1984	296,8	Mar. 1987	390,0
Dec. 1984	299,0	Jun. 1987	393,7
Mar. 1985	301,7	Sep. 1987	438,4
Jun. 1985	306,2	Dec. 1987	438,4
Sep. 1985	328,2	Mar. 1988	444,9
Dec. 1985	328,2	Jun. 1988	448,9
Mar. 1986	339,4	Sep. 1988	504,9
Jun. 1986	342,6	Dec. 1988	506,9
Sep. 1986	377,6	Mar. 1989	520,9
Dec. 1986	385,1	Jun. 1989	533,0

**PLANT COST INDEX (1999 – 2000)**

Quarter	Index	Quarter	Index
Mar. 1999	1 822.3	Mar. 2000	1 936.7
Jun. 1999	1 822.3	Jun. 2000	1941.5
Sep. 1999	1 917.5	Dec. 2000	2 050.0
Dec. 1999	1 927.0		

The cost of capital equipment changes with time. The Plant Cost Factor provides a rough measure of this change that can be used to estimate the price of equipment today if you know what it was in the past.

For example, if you wanted an estimate of the price for an item today (June 1988) and all you had was its price in June 1985 of R345 000 you find the Plant Cost Factors for June 1985 (306.2) and for June 1988 (448.9) and note that the equipment price in June 1988 will be approximately 448.9/306.2 of the price in June 1985. Therefore, the price in June 1988 = R35 000 x 448.9/306.2 = R505 770.

**TABLE 2: ESTIMATING PLANT CAPITAL COSTS FROM EQUIPMENT COSTS**

Plant type	Solids handling	Hydro-metallurgical	Chemical
Equipment	1,00	1,00	1,00
Erection of items	0,11	0,17	0,11
Structural & Buildings*	0,26	0,24	0,21
Civils	0,17	0,27	0,38
Piping & ducting	0,14	0,35	0,59
Electrical	0,26	0,25	0,35
Instruments	0,10	0,20	0,27
Installed plant	2,04	2,48	2,91
VAT (14%) x 1,14			
Site prep. (5%) x 1,05			
Construction Management (15%) x 1,15			
Contingency (15%) x 1,15	3,23	3,93	4,61

\*Plant support structure and simple sheeted covering minor portions of plant only.

A rough way to estimate the capital cost of a processing plant is to base the estimate on the cost of the major equipment. (The cost of the major equipment is used because it is easy to identify the number, size and cost of this equipment). The procedure is to multiply the cost of major equipment by various factors that account for different aspects of building a plant. The factors taken into account in the above table

include civils (cost of concrete work and ground preparation), electrical (cost of motors, power supply systems, wiring and electrical controls), contingency (unforeseen costs).

- Note:
- (1) This approach is rough and used only to get rough estimates quickly. Better estimates require more detailed design work to be completed and so cost more and take more time.
  - (2) The various factors such as erection of items (= construction and installation), structurals, etc have been obtained from average costs of plants that have already been built. Look carefully at these factors and decide if they are appropriate or not for your 'plant in the barge'.

#### **INVESTIGATION 1.4**

Because the plant is going to operate hundreds of miles from its home base at the mouth of the river, it is important to design the process so that if some equipment breaks down, the process can continue operating while the breakdown is being fixed. Look at the flow sheet and suggest what needs to be done to do this.

Think as broadly as you can about what is needed to make the barge completely self contained so that it can function efficiently for at least a month with no supplies or help from the outside world. Make a list of the equipment and systems it would need.

### **INVESTIGATION 1.5**

You are required to produce a more detailed design of the plant on the barge – one that will be given to mechanical and electrical engineers so they can do their part of the plant design and construction. The flow sheet of the plant (with duplicate equipment, bins, etc) is given below. You need to select/calculate the size of each item of major equipment (conveyors, crushers and screens) using the information given below. You will also need to do a new plant layout (because the plant is more complex than the one you worked with in investigation 3).

The electrical engineer in your team wants to know the power requirements needed for each item of major equipment. Supply him with that information after you have selected your equipment.

#### **Available Information**

(Reference for the equipment selection and power information: 'Handbook on Estimation of Metallurgical Process Costs', W Ruhmer, Mintek Special Publication No 14, 1991)

#### **Ore Specifications**

- The lumps of ore in the transporters should all be smaller than about 5 cm.
- Size distribution of the ore excavated from the river bank. This will obviously be variable. Assume that the coarsest and finest ore fed to the plant will have size distributions as indicated in the table below:

**TABLE 1: Size Distribution of the Mined Ore**

<b>Lump Size R (cm)</b>	<b>Mass % of Ore that consists of lumps smaller than Size R</b>	
	<b>Coarse Ore</b>	<b>'Fine' Ore</b>
18	100%	100%
12.5	97%	100%
9	87.5%	94%
6.3	66.3%	84%
4.5	36.9%	66%
3.3	10.9%	46%

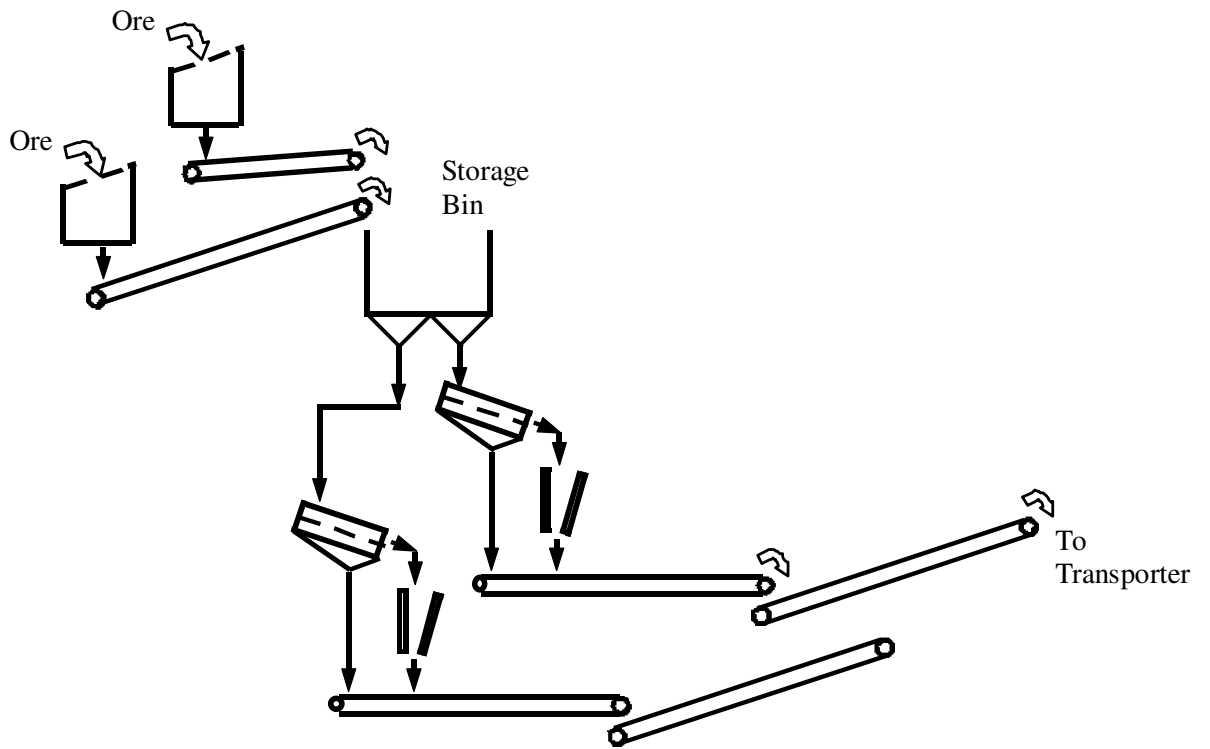

## SELECTING A CONVEYOR BELT

### *Minimum belt width factors*

Material Classification	Ratio belt width/max lump
Run-of-mine ore (The one received from the "mine")	3,0
Crusher product – sized	3,4
Crusher product – fines removed	4,0
Sized material from screen	4,66

To establish belt width, multiply maximum lump size by the applicable ratio from the above chart. Round off the number to the next largest belt width in the belt selection tables. The most economical selection usually dictates the use of maximum belt speeds.

### *Maximum belt speeds recommended*

Material being conveyed	Max Belt speed m/sec	Min Belt width mm
Coal, damp clay, soft ores, overburden and earth, fine-crushed stone	2	450
	3	500-600
	4	1050-1200
Heavy, hard, sharp-edged ore, coarse crushed stone	1,75	450
	2,50	500-600
	3	1050-1200

Capacity of troughed belt conveyors, tonnes per hour for a belt speed of 1 metre per second.

Type of idler	Belt width	Belt capacity (t/hr per m/s)			
		Material bulk density (kg/m <sup>3</sup> )			
		800	1600	2000	2400
3-roll	450	48	96	120	144
	600	93	185	231	278
	750	152	303	379	455
	900	225	450	563	676
	1050	313	626	783	939
	1200	414	828	1035	1241

### Power to Drive Conveyors

The total power calculated from the tables is that which is required at the drive shaft. The size of the motor required will be greater than this value by whatever is allowed for the efficiency of the speed reducers between motor and drive shaft.

#### *Example:*

Width of conveyor	900 mm
Length of conveyor	250 m
Design load	800 t/h
Material density	1600 kg/m <sup>3</sup>
Speed	2 m/s
Lift	50 m

Power to drive empty conveyor (the numbers in bold are from the Tables) = 2 x **4,3** = 86 kW  
 Power to move load horizontally = **19,0** kW  
 Power to lift load = **122,6** kW

Total = 150,2 kW  
 Efficiency of speed reducer and coupling = 0,8  
 Therefore required drive power =  $\frac{150,2}{0,8}$  = 187,8 kW  
 Select 200 kW motor

*Power (kW) to drive empty conveyor for each metre per second of belt speed*

Belt width	Length of conveyor, m											
	25	50	75	100	125	150	175	200	225	250	275	300
450	0,5	0,6	0,8	0,9	1,1	1,2	1,4	1,5	1,7	1,8	2,0	2,1
600	0,6	0,8	1,0	1,2	1,4	1,6	1,8	2,2	2,2	2,4	2,5	2,7
750	0,9	1,1	1,4	1,6	1,9	2,1	2,4	2,7	2,9	3,2	3,4	3,7
900	1,2	1,5	1,9	2,2	2,6	2,9	3,3	3,6	4,0	4,3	4,7	5,0
1050	1,5	2,0	2,4	2,9	3,4	3,8	4,3	4,7	5,2	5,6	6,1	6,5
1200	1,9	2,4	2,9	3,5	4,0	4,6	5,1	5,7	6,2	6,8	7,3	7,9

*Power (kW) to move load horizontally*

Tonnes per hour	Length of conveyor, m											
	25	50	75	100	125	150	175	200	225	250	275	300
50	0,3	0,4	0,5	0,5	0,6	0,7	0,8	0,9	1,0	1,1	1,1	1,2
100	0,6	0,7	0,9	1,1	1,3	1,4	1,6	1,8	1,9	2,1	2,3	2,5
200	1,2	1,5	1,8	2,2	2,5	2,9	3,2	3,6	3,9	4,2	4,6	4,9
300	1,7	2,2	2,8	3,3	3,8	4,3	4,8	5,3	5,8	6,3	6,8	7,4
400	2,3	3,0	3,7	4,4	5,0	5,7	6,4	7,1	7,8	8,4	9,1	9,8
500	2,9	3,7	4,6	5,5	6,3	7,2	8,0	8,9	9,7	10,5	11,4	12,3
600	3,5	4,5	5,5	6,5	7,6	8,6	9,6	10,7	11,6	12,7	13,7	14,7
700	4,1	5,2	6,4	7,6	8,8	10,0	11,2	12,4	13,6	14,8	16,0	17,2
800	4,6	6,0	7,4	8,7	10,1	11,4	12,8	14,2	15,5	16,9	18,2	19,6
900	5,2	6,7	8,3	9,8	11,3	12,9	14,4	15,9	17,5	19,0	20,5	22,1
1000	5,8	7,5	9,2	10,9	12,6	14,3	16,0	17,7	19,4	21,1	22,8	24,5
1200	6,9	9,0	11,0	13,1	15,1	17,2	19,2	21,3	23,3	25,3	27,4	29,4
1400	8,1	10,5	12,9	15,3	17,6	20,0	22,4	24,8	27,2	29,6	31,9	34,3
1600	9,3	12,0	14,7	17,1	20,2	22,9	25,6	28,3	31,1	33,8	36,5	39,2
1800	10,4	13,5	16,5	19,6	22,7	25,7	29,8	31,9	34,7	38,0	41,1	44,1
2000	11,6	15,0	18,4	21,8	25,2	28,6	32,0	35,4	38,8	42,2	45,6	49,0

*Power (kW) to lift or drop the load*

Tonnes per hour	Lift or drop, m										
	5	10	15	20	25	30	35	40	45	50	100
50	0,7	1,4	2,0	2,7	3,4	4,1	4,8	5,4	6,1	6,8	13,6
100	1,4	2,7	4,1	5,4	6,8	8,2	9,5	10,9	12,3	13,6	27,2
300	4,1	8,2	12,3	16,3	20,4	24,5	28,6	32,7	36,8	40,9	81,7
400	5,4	10,9	16,3	21,8	27,2	32,7	38,1	43,6	49,0	54,5	109,0
500	6,8	13,0	20,4	27,2	34,0	40,9	47,7	54,5	61,3	68,1	136,2
600	8,2	16,3	24,5	32,7	40,9	49,0	57,2	65,4	73,6	81,7	163,4
700	9,5	19,1	28,6	38,1	47,7	57,2	66,7	76,3	85,8	95,4	190,7
800	10,0	21,8	32,7	43,6	54,5	65,4	79,6	87,2	98,1	109,0	217,9
900	12,3	24,5	36,8	49,0	61,3	73,5	85,8	98,1	110,3	122,6	244,5
1000	13,6	27,2	40,9	54,4	68,1	81,7	95,3	109,0	122,6	136,2	272,4
1200	16,3	32,7	49,0	65,4	81,7	98,1	114,4	130,8	147,1	163,5	326,9
1400	19,1	38,1	57,2	76,3	95,3	114,4	133,5	152,5	171,6	190,7	381,4
1600	21,8	43,6	65,4	87,2	109,0	130,8	152,5	174,3	196,1	218,0	435,0
1800	24,5	49,0	73,5	98,1	122,6	147,1	171,6	196,1	220,6	245,2	490,3
2000	27,2	54,5	81,7	109,0	136,2	163,4	190,7	217,9	245,2	272,5	544,9

## SELECTING A JAW CRUSHER

Top view of crusher

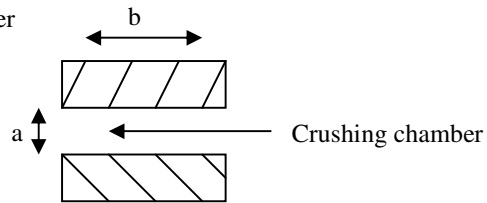

The size of a jaw crusher is expressed as  $a \times b$

Size, cm	25 × 53	36 × 61	46 × 81	64 × 91	76 × 107	107 × 122	127 × 152
Mass, t	2,948	6,441	11,068	21,364	31,661	53,297	203,209
Power, kW	18,5	30	55	90	132	160	250

Setting, mm	Capacity*, t/h						
12	5						
19	6						
25	8	15					
38	14	23					
51	17	27	36				
63	20	34	45				
76		39	54	82			
89			64	91	127		
102			73	103	145		
127				130	172	272	
152				157	200	302	
178					233	332	
203						368	450
229						424	490
254						435	540
305						508	600

\* Capacities are based on the crushing of loose limestone with a bulk density of  $1545 \text{ kg/m}^3$  and a relative density of 2,6.

### SELECTING A VIBRATING SCREEN

$$\text{Screening Area} = \frac{\text{TF} - \text{Oversize}}{A \times B}$$

Where TF = total feed to screen (t/h).  
Oversize= amount of feed larger than screen deck openings (t/h).  
A = standard screening capacity.  
B = composite efficiency factor (assume this has a value of 1 ).

Assume the screen will be twice as long as it is wide.

Standard screening capacity

Size of square opening mm	Capacity t/h/m <sup>2</sup>	
	Ore	Coal
1,0	2,9	2,2
2,0	3,7	2,8
3,2	5,5	4,2
4,7	7,3	5,6
6,4	8,6	6,6
9,5	11,6	8,6
12,7	13,7	10,2
15,9	15,6	11,8
19,0	17,6	13,3
22,2	19,1	14,5
25,4	20,7	15,6
31,8	23,4	17,9
38,1	26,2	19,5
50,8	30,3	22,6
63,5	33,0	24,7
76,2	35,2	26,3
101,6	37,7	28,4
127,0	39,7	29,9

## APPENDIX 3

### PRME1002: INTRODUCTION TO PROCESS and MATERIALS ENGINEERING

#### THURSDAY 2Q1bT – 14<sup>th</sup> April, 2005: CASE STUDY 2

##### ***General Learning Outcomes for Case Study 2:***

*The general learning outcomes for this case study have to do with the following:-*

- ***Engineering Practice:*** *Understanding a Process by Interpreting a Flow Sheet and a Material Balance.*
- ***General Processing Knowledge:*** *Preparation of Raw Materials; Some Simple Separation Processes.*
- ***Technical Concepts:*** *Concentration/Composition and Mass Balance Principles.*

##### **CASE STUDY 2: SUGAR MAKING**

Your design team, fresh from the preliminary design of the “plant on the barge”, has now been given a new project in the sugar making industry. Your boss knows your team have no experience with sugar making and so has given your team some time to “get up-to-speed” on this process. This case study aims to develop your ability to get to grips with a new process by developing skills in “reading” flow sheet and material balance information.

##### **Case Study 2.1: Interpreting a Flow Sheet to Understand a Process**

***Intended Learning Outcomes:*** *At the end of today’s session you should:*

- 1) *Be comfortable with imagining, from some knowledge of raw materials, what processing steps would be necessary to get to the desired product.*
- 2) *Be able to put together a crude flow sheet that they can justify.*
- 3) *Be free to make errors as long as they learn from them.*
- 4) *Have an appreciation for raw material preparation and handling.*
- 5) *Have an understanding of different unit operations and the logic they follow in a process flowsheet.*

**Task 1: Just Thinking! Do this Task on your OWN not as a Group!!** [Time = 5 minutes]

Put your name/group number on a piece of paper (which you will hand in immediately after the task has been done). Then write down what you imagine the process of sugar making involves. When you are done, please wait for the next question. Do not have a discussion with your group mates while you wait.

*{Note: The purpose of this task is to give us an idea about your perceptions BEFORE you have had any exposure to sugar making at all. This will help us to help you later – so give your honest perceptions!!}*

### **Task 2: How to Get an Overview of a Process** [Time = ?? minutes]

In your search for information on sugar making, you come across the flow sheet presented below. You can see that it is quite complicated. Through the tasks you will do today, you will work on this flow sheet as you learn how to decode flow sheets in general and how to interpret the information they contain.

#### **Getting an Overview of the Overall Process**

- a) Look at the flow sheet quickly and get a general feel for what is in it.
- b) Represent the overall process with a single block with streams flowing into and out of it. Draw your diagram and label it appropriately. (If there are too many streams do something sensible!)
- c) You can get clues about what is going on in the process by thinking about the nature and purpose of each of the streams you identified in (b). Look at each of these in turn and write down what you think that stream (i) consists of (ii) what its purpose is and (iii) which kind of stream it is from the following list:-
  - A major stream – a stream on the direct route from raw materials to desired product/s.
  - Ancillary stream – a service stream that supplies needed chemicals, process water or air.
  - Product or bi-product stream – containing the desired product and/or bi-products
  - Waste, effluent or discard streams.
  - None of the above – an ‘arb’ stream.
- d) Based on what you found in (c), what can you say about the nature of the major feed stream to the process?
- e) When you are done call a TA for feedback. If you have to wait, start the next task.

### **Task 3: How to Get an Overview of the Process Logic** [Time = ?? minutes]

The ‘process logic’ explains why a process is organized the way it is. In order to get a handle on a complex process, it is best to understand it broadly before you try and understand the details. Task 3 will give you experience in identifying the major stages or sub-divisions of a process.

#### **Identifying the Logical Sub-Divisions (Stages) of a Process**

- a) Without looking at the flow sheet, think about the process and try to identify 2 or 3 (maybe 4) obvious stages that the cane must go through in order to be turned into sugar. Represent each stage by a block and indicate what happens in each block. In your diagram, draw in the major process and product streams. (For the moment ignore minor streams). Briefly describe the nature of each of the major streams in your diagram.

*Example from the ‘Plant on the Barge’: Stage 1 = receiving the ore (and consists of feed hopper, feed conveyor and storage bin); Stage 2 = sizing and size reduction (consisting of screen and crusher); Stage 3 = delivery system (consists of product conveyors). (Someone else might combine stages 2 & 3 and say there were only 2 stages in the process.)*

- b) Now look at the flow sheet. In order to orientate yourself and not get confused by all the detail, you first need to establish the main processing route for raw material to desired product. To do this, identify the effective starting point of the process and then identify which stream leaving that block is the main sugar-containing stream. Follow that stream to the next block. Follow the main sugar-containing stream from that block to the next block and so on until you get to the final desired product. (For some blocks you will have to think

a bit and look around the flow sheet to figure out what is in each stream leaving that block.) Pencil in the major processing route you have identified.

- Now follow step by step the main processing route you have marked. Think about what is happening at each step and be alert for points in the process at which the nature or purpose of what is happening changes significantly. These points mark logical subdivisions in the process. Take note of them.
- Now draw a simplified flow sheet of the process indicating only 2 or 3 (or maybe 4) stages like you did in task (a). Give a meaningful label to each stage and to each process stream.
- When you are done call a TA. If you have to wait, try the optional task in (f).
- {Optional}* The process can be divided into 2, 3 or 4 subdivisions. Sketch two sub-divisions of the process different from the one you did in (d).

**Task 4: The Process Logic of each Processing Stage** [Time = ?? minutes]

Once you have identified the major stages of a process and what is supposed to happen in each stage, you have the information needed to start making sense of the detail in each stage. In this task, you will explore what is going on in the Stages 1, 2 and 4 of the sugar making process (as depicted below).

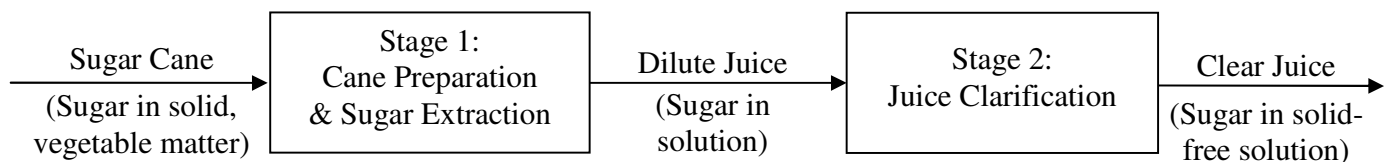

**Exploring the Detailed Logic of a Processing Stage**

- Examine each of the “processing units” in Stage 1 and the streams to and from each unit in that stage. Write a brief description of what you think each process stream consists of and what each unit does.
- Read my answer to (a) over the page and make sure you know what is required of you.
- Repeat task (a) for Stage 2 of the process.
- When you are done call a TA. If you have to wait, start the next task (e).
- Repeat task (a) for Stage 4 of the process (Raw Sugar Processing). (Leave Stage 3 for the moment. It is trickier and will be done later). Streams 29 and 34 feed Stage 4. Both consist of sugar crystals with some adhering molasses.

**Description of Stage 1:**

*Cane Cleaning:* Feed = solid cane with leaves (and assorted muck – look at stream 15!!). Product 1 (Str 2) = leaves and the tops of the cane so stream 3 must be cane without leaves and tops. Cane ‘cleaning’ therefore appears to involve stripping off leaves and chopping of the top of the cane stalks.)

*Cane Breaking:* The name suggests that the cane stalks are broken into smaller pieces – probably in preparation for ‘cane milling’. Therefore, stream 4 must consist of bits of broken cane.

*Cane Milling:* Water is added (stream 5) and bagasse (fibrous residue) is removed (as stream 6) leaving juice (stream 7). The processing unit must do some kind of grinding to squeeze

*out the sugar in the cane. The water must assist in this sugar extraction process. There must be some kind of screen or straining system to separate the fibrous residue from the juice. Obviously, the bagasse will be wet after this straining process and so there must also be some kind of system that makes sure there is very little juice adhering to the bagasse – water washing seems the most obvious.*

### **2.1.1 Reflection**

Look at your responses for questions 2.1.2 and 2.1.3. What are the differences? What is now clear that was not before? What questions did you have before that were clarified and what assumptions did you have to make to put together the initial description for 2.1.2?

## CASE STUDY 2

### Task 2.2 Second half of the process

The second half of the process is trickier than the first. The only information that you have about this part of the process is that the feed is juice. This juice is what the first half of the process produced. Somehow, at the end of this you should have crystals. Now your boss understands that this part is difficult and does not want to stress you out unnecessarily. Towards that end he presents you with this crude block diagram.

Fig. 2

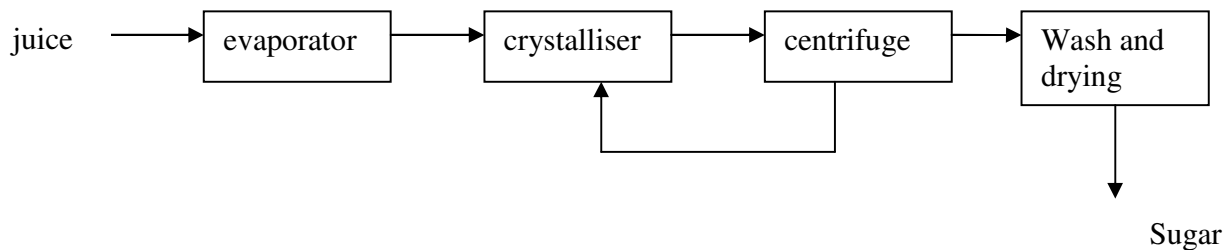

#### **Task 2.2.1**

He then asks you to do what he calls a ‘decoding’ exercise. In other words, the words in each block are codes that you need to break in order to know, ‘see’ or conceptualise the operations in each block. For each block write briefly about what happens in each block, one or two lines per block.

**2.2.1** After you have done this, he presents you with what looks to you like a hectic flowsheet, arrows going everywhere and blocks. This is the real process. He also gives you schematics of process equipment and their descriptors and asks you to make head or tail of this. He wants to know how each piece of equipment operates, and what the nature of the product is from each piece of equipment.

#### **2.2.2 Reflection**

This was decidedly exhausting. But the intrepid discoverer that you are, you are not disheartened. Now that you know what an evaporator does, is there something else that could do the same job? What about the crystalliser and the centrifuge? If you think it will help, think of the lab visit. Justify the choices that you make here. Include all assumptions etc. what made this process difficult?

**2.2.3** You have just completed a flowsheet. Throughout this process there must have been words that you did not understand or had never seen before. What ever these are, write them down and mention at which stage in the process you encountered them. This means include the operation associated with that word.

## CASE STUDY 2: Investigation 2.3

### Reading a Flow Sheet and 'Mass Balance'

Now you have a whole flowsheet and have a better understanding of what it takes to make sugar. For your records, a complete flowsheet is attached. Unfortunately understanding a process is more than just knowing the equipment and the sequence of unit operations. Because processes change raw materials into products one of the best ways to understand a process is to track the quantities of components in the streams and monitor the changes. These changes are captured in what is called a mass balance.

**2.3.1** The table below is a mass balance of the first half of the process. Study this information so that you can explain to your boss what is going on in the process it represents. Write him a brief memo explaining the important details of the process, remembering that he already knows about this part of the process (you explained that to him last time).

Fig. 3

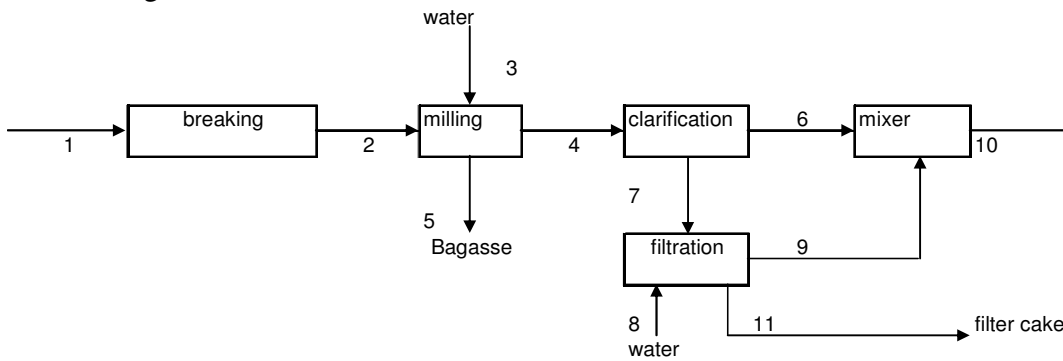

	Stream no.	1	2	3	4	5	6	7	8	9	10	11
	Total Flowrate kg/h	550	550	110	484	176	141	343	110	98	239	3
Brix	Sugar	61	61	0	54	6	35	10	0	1	36	
	Other	146	146	0	138	8	11	25	0	1	12	
	Water	69	69	110	93	86	71	22	110	96	167	
	Fibre	275	275	0	199	76	24	286	0	0	24	2
	Concentrations %											
Brix	Sugar	11	11	0	11	3	25	3	0	1	15	
	Other	27	27	0	28	5	8	7	0	1	5	
	Water	13	13	100	19	49	51	6	100	98	70	
	Fibre	50	50	0	41	43	17	83	0	0	10	

**2.3.2** If you have understood the relationships between the streams, the unit operations and the numbers, think about how you would represent the relationships numerically. To do this take one unit operation for example the mixer, and work with the numbers associated only with it i.e. streams 6, 9 and 10. Repeat this for the rest of the unit operations for all the components.

### 2.3.3 Reflection

Think through the difficulties that you had with this task. Write these down including any questions that you had as you worked through the material. If you have not understood the relationships that are mentioned in question 2.3.2, write down why you think you were unable to understand them.

**CASE STUDY 2: Investigation 2.4**

The farmer while rummaging through his shed which is situated at the plantation comes across this incomplete table. He is excited about this discovery but does not know what the numbers mean or whether in fact it is worth keeping. He has kleptomaniac inclinations however and as such he invites your boss over to the plantation to discuss the “find”. Your boss does not know yet what this is about but he goes. The sheet gets given to him. Now your boss, typical of an engineer with years of processing experience does not want to admit that he is ignorant. Instead he mumbles something about production figures, beats a hasty retreat and asks you, “as part of understanding the process”, to figure out what is going on for each situation.

**2.4.1** Write down how you would relate the different streams, decide which streams are exit streams and which are input. For situations 2, 3 and 4, fill in the missing information. Decide what unit operation this is and justify your answer.

Key: F Total flowrate  
 W Water  
 S Sugar  
 O Other

Table 1

	Stream 1				Stream 2				Stream 3			
	F	W	S	O	F	W	S	O	F	W	S	O
Situation 1	50	0.58	0.16	0.26	20	0.7	0.1	0.2	30	0.5	0.2	0.3
Situation 2	40	0.72	0.08	0.2		0.516	0.22			0.4	0.3	0.3
Situation 3	60	0.25	0.35	0.4	100				40	0.35	0.45	0.2
Situation 4	70				130	0.25	0.35	0.4	60	0.44	0.25	0.31

**2.4.2 Reflection**

How was this process for you? Make a note of any questions, assumptions, comments etc..

### Strainer

The debris-laden dirty fluid enters the strainer's large bottom chamber A where the line velocity is reduced. Flow continues upward, passing radially through the "sealed" screen element. Unwanted materials are trapped on the inside of the screen. The flow is uninterrupted and the strained clean fluid continues into the outer annulus of the strainer body and exits through the outlet nozzle.

When cleaning is required, the automatic backwash valve opens the system to atmosphere – causing a high velocity reverse flow across the isolated section of the screen. Dirt and debris are flushed from this segment of the screen into the backwash arm and out of the strainer via the backwash piping.

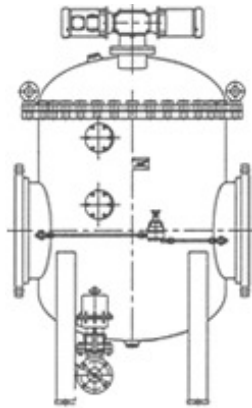
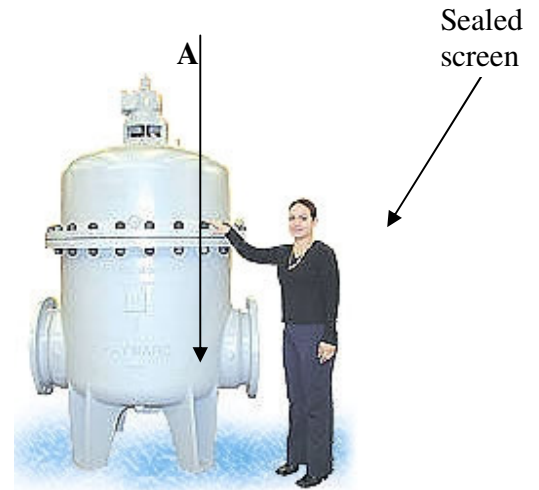

### Conveyor

A conveyor moves material. It moves cardboard boxes, wood boxes, metal boxes and plastic boxes.

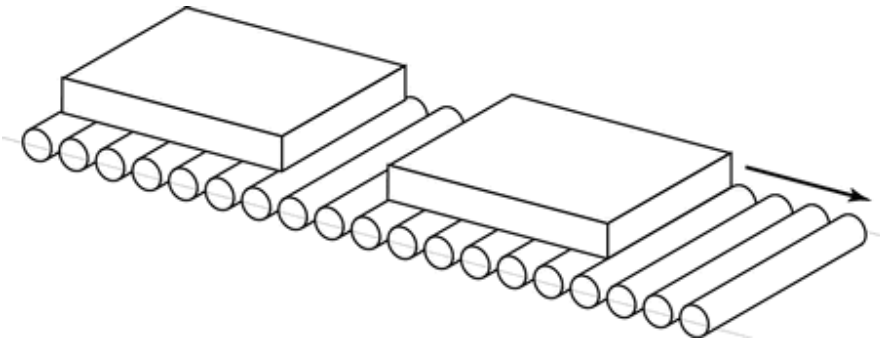

### **BY GRAVITY**

This is called a GRAVITY CONVEYOR. A conveyor can do more. It can move boxes UP against gravity . . . DOWN . . . or HORIZONTAL on a moving belt.

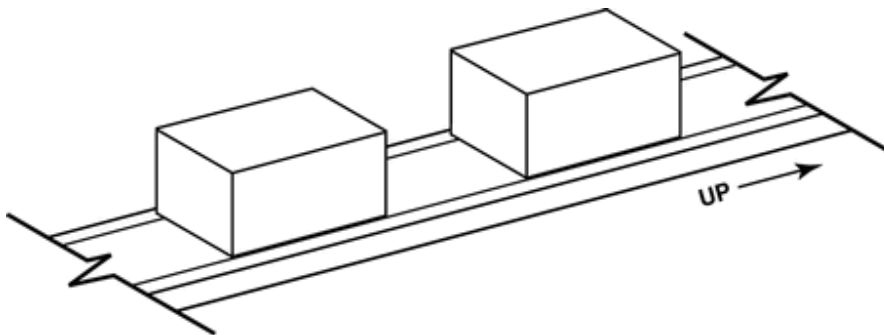

The belt is moved by electric power.  
This is called a BELT CONVEYOR.

### **Shredder**

After harvesting, the cane sugar is transported to the mill where the cane billets are reduced by the shredder machines into fibrous materials. Then the sugar juice is removed by the extraction station. Shredder ruptures a high percentage of sucrose bearing cells in the cane and simultaneously presents the raw material to the extraction plant in long fibre particles.



## **Mill**

There are many ways to reduce the particle size of materials. One of the most common pieces of equipment used is the roller mill.

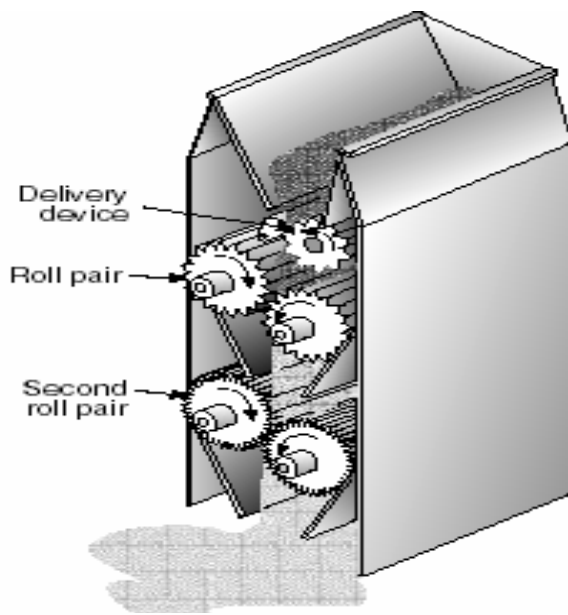

This piece of equipment is capable of producing what is often termed in the industry as a “satisfactory grind.” However, excessive size reduction can result in wasted electrical energy, unnecessary wear on mechanical equipment. Roller mills accomplish size reduction through a combination of forces and design features. If the rolls rotate at the same speed, compression is the primary force used. If the rolls rotate at different speeds, shearing and compression are the primary forces used. If the rolls are grooved, a tearing or grinding component is introduced.

Coarse grooves provide less size reduction than fine grooves do. There is little noise or dust pollution associated with properly designed and maintained roller mills. Their slower operating speeds do not generate heat, and there is very little moisture loss. Particles produced tend to be uniform in size; that is, very little fine material is generated. The shape of the particles tends to be irregular, more cubic or rectangular than spherical. The irregular shape of the particles means they do not pack as well.

### **Clarifier**

The juice is clarified by adding milk of lime and carbon dioxide. The carbon dioxide bubbles through the mixture forming calcium carbonate, a chalk-like crystal which attracts the non-sugar plant materials like wax, fats, and gums from the juice. In a clarifier, the calcium carbonate and the other materials fall out of the sucrose solution and

settle to the bottom. The sugar cane juice, has a pH of approximately 5.5. In addition to being treated with lime it is heated to the boiling point. The main purpose of liming is to neutralize the acidity and to prevent inversion of sucrose.

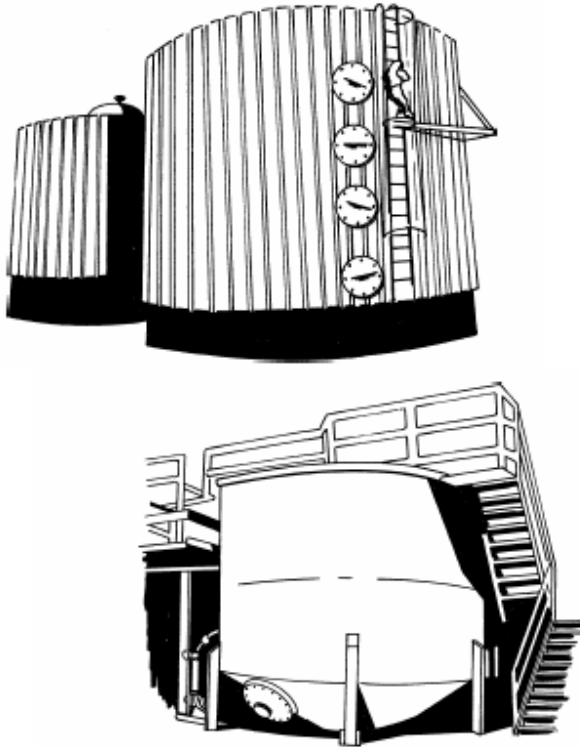

## **Filtration**

A rotary drum vacuum filter (RDVF) is a continuous filter wherein the solid constituent in a pulp or slurry is separated by a porous filter cloth or other media rotated through the pulp or slurry, with vacuum applied to the inner surface to cause the solids to accumulate on the surface as a cake or layer through which the liquid is drawn. The process cycle of the RDVF is continuous. Each revolution consists of cake formation, cake washing (if required), drying and cake discharge. As the drum rotates - partially submerged in the slurry - vacuum draws the liquid through the filter medium (cloth) on the drum surface which retains the solids. The vacuum pulls air (or gas) through the cake and continues to remove liquid as the drum rotates. If required, the cake can be washed prior to final drying...and discharge. The filtrate and air flow through the internal filtrate pipes, through the rotary valve and into a vacuum receiver where the liquid is separated from the gas stream. Vacuum is normally developed by a liquid ring vacuum pump or barometric leg. Multiple receivers connected to the filter valve allow for the separation of mother liquor

from the wash liquor, and vacuum levels can be varied at the cake forming and washing/drying zones.

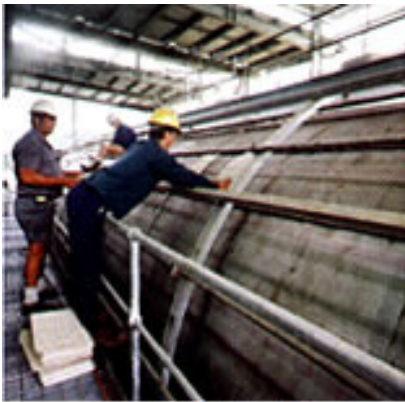

*Rotary vacuum filter*

### **Vacuum Pans**

The crystallisation of sucrose (sugar) out of syrup or molasses is carried out in large vessels operated under a vacuum called vacuum pans. The first step in sugar boiling is *seeding*. The mixture of sugar crystals and syrup or molasses is called *massecuite*. Sugar boiling is a complex art that requires an individual with unique skills and experience.

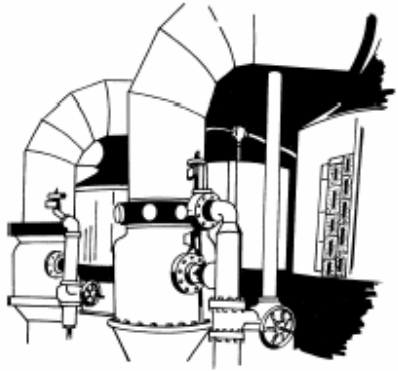

## Evaporators



The clarified juice contains about 85% water. Most of this water is removed in steam-heated multiple effect evaporators operating under a vacuum. Evaporation is the process of removing water from a solution by boiling the liquor in a suitable vessel, the evaporator and withdrawing the vapour. If the solution contains dissolved solids the resulting strong liquor may become saturated so that crystals are deposited.

## Crystalliser

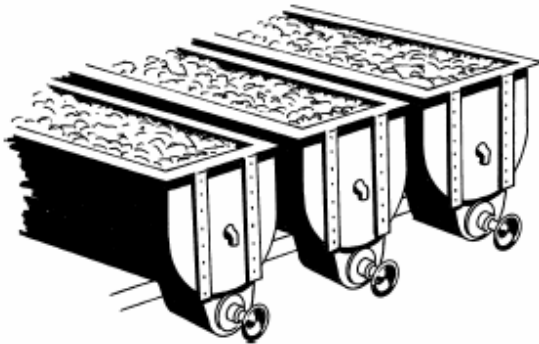

Crystallisation is the formation of crystals from a solution or from a melt. The process consists essentially of two stages which proceed simultaneously but which can be independently controlled. The first stage is the formation of nuclei or small particles which must exist in the solution before the process can start and the second stage is the growth of the nuclei. Nucleation may happen spontaneously if conditions are suitable or but in many cases seed crystals may be added to aid the process. The crystallisation process is takes place in the crystallisers where the mixture of mother liquor and crystals is *cured* by slow cooling and stirring for a period of 36 hours. This process increases the recovery of sucrose from the molasses.

### Centrifugals

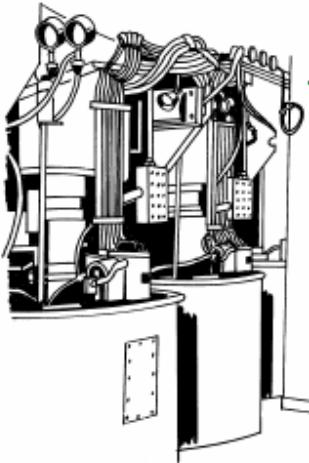

*Continuous centrifuge*

The next step in sugar manufacturing is initial separation of sugar crystals from molasses. This is accomplished by centrifugal force in batch or continuous machines called centrifugals. Basically, a centrifugal consists of a drum covered with a fine screen rotating at high speed (1,200 rpms) on its vertical axis. The molasses is forced through the screen producing a pre-refined sugar stock.