

A Process Synthesis Approach to Flowsheet Design for the minimization of Carbon Dioxide Emissions

James Alistair Fox

A thesis submitted to the Faculty of Engineering and the Built Environment, University of the Witwatersrand, Johannesburg, in fulfillment of the requirements for the degree of Doctor of Philosophy.

Johannesburg, 2011

Declaration

I declare that this thesis is my own unaided word, unless otherwise stated. It is being submitted for the degree of Doctor of Philosophy to the University of the Witwatersrand, Johannesburg. It has not been submitted before for another degree or examination at another university.

James Alistair Fox

_____ day of _____ 2011

Overall Abstract

There is increasing pressure on industries to increase their productivity while simultaneously reducing their environmental impact. In order to meet these new challenges, energy and raw materials need to be put to the best use they can be.

Typically the features of a process are fixed at an early stage in a design. While doing so allows a design to be conveniently arranged into discrete stages, it also results in the loss of many opportunities for innovation. In order to preserve both the chance for innovation and ease of management, new and systematic methods are needed to design processes. The purpose of this research is to demonstrate the use of a novel method of synthesizing process flowsheets, using a graphical tool which we called the GH-space, with the overall goal of minimizing carbon emissions while making the best use of raw materials and for a given production.

Typically mass, energy and work balances are done on flowsheets as a means of analysis. In other words, the flowsheet determines the balances. Unfortunately, once the flowsheet and chemistry of the process has been decided, most of the opportunities for improvement and innovation have been lost.

The GH-space technique uses fundamental thermodynamic principles to allow the mass, energy and work balances to define targets for the performance of a process. Furthermore processes and unit operations can be defined as vectors in the GH-space. Using the targets, one can combine the vector processes in such a way as to approach the target. These vector processes, and the way they are combined, can then be interpreted in terms of flowsheets. This is opposite to what is normally done and allows the process balances to determine what the best flowsheet might look like, allowing for great innovation from the very start of a design. In addition to this, probably the greatest advantage of the GH-space technique is that processes of great complexity can all be analyzed on a set of two-dimensional axes.

Every process that converts some feed material to a product material has a heat and a work associated with it in order to perform that conversion. Using the relationship that exists between heat and work allows the target of a process to be determined and for flowsheets to be formulated that allow these targets to be met. In this research the flows of heat and work are illustrated with the analogy of a heat engine. This is not the only way for heat and work to flow between process units but it allows for convenient illustration of the heat and work interaction between individual process units.

Three case studies were chosen for their reputations as high carbon dioxide emitters: Coal Gasification, Methane Steam Reforming and Fischer-Tropsch synthesis. The GH-space method was then applied to these three examples to determine if these emissions were just a price that had to be paid or if there was any room for improvement.

The case studies shown herein were ideal cases to show the power and flexibility of the technique as well as illustrate a method of using the technique, there is a great deal of additional

details that would still need to be considered for a practical, functioning, plant to be built, such as catalysis and materials of construction, to name only two. While the GH-space provides insight into what the theoretical maximum efficiency might look like it does not necessarily show what the absolute maximum efficiency might be. Another advantage of the GH-space is that it can handle as little or as much detail as is desired.

It was shown in this work that with clear understanding of the flows of mass, energy and work within a process it is possible to design process flowsheets that are potentially carbon negative, produce the intended product and also produce power as a co-product.

Acknowledgements

I would like to express my undying gratitude to my parents, Stuart and Joan Fox, whose infinite patience and unwavering support gave me guidance through the brightest, and darkest, moments of my life. It is to them that I dedicate this work.

To my supervisors; Professor Diane Hildebrandt and Professor David Glasser, their insight, motivation and guidance have helped me to get this far. I would also like to thank them for giving me a chance when no one else would.

Thanks also go to Doctor Bilal Patel, for his invaluable input and assistance throughout my research.

My thanks also go to Doctor Brendon Hausberger and Doctor Simon Holland, for providing me the opportunity to work on some commercial projects and gain the invaluable experience that came with those projects. It was an honor and a privilege to work with you both.

I acknowledge the financial assistance from the Center of Materials and Process Synthesis (COMPS), the National Research Fund (NRF), the South African Research Chairs Initiative (SARChI) and the University of the Witwatersrand.

Contents

Declaration.....	2
Overall Abstract.....	3
Acknowledgements.....	5
List of Figures.....	9
List of Tables.....	12
1 Overall Introduction.....	13
1.1 The Contribution.....	13
1.2 The Method.....	15
References.....	17
2 A Graphical Approach to Synthesizing Flowsheets: Application to Gasification.....	20
Abstract.....	20
2.1 Introduction.....	21
2.2 The enthalpy, Gibbs free energy plane: the GH-space.....	22
2.2.1 Reactions.....	22
2.2.2 Compression.....	25
2.2.3 Mixing and separation.....	27
2.2.4 Vector addition.....	28
2.2.5 Heat and work.....	28
2.3 Application to gasification.....	33
2.3.1 The reactions in gasification and the overall material balance.....	33
2.3.2 Application to the GH-space.....	35
2.4 Conclusion.....	52
References.....	54
3 A Graphical Approach to Process Synthesis and its application to Steam Reforming.....	56
Abstract.....	56
3.1 Introduction.....	57
3.2 The graphical technique.....	59
3.2.1 A simple process.....	59
3.2.2 Work addition.....	60
3.2.3 Graphical representation of the process work and heat requirements.....	64

3.3	Application to steam reforming.....	70
3.3.1	Defining the system	70
3.3.2	The material balance and the $\Delta H - \Delta G$ plot.....	73
3.3.3	Selection of operating temperatures.....	80
3.3.4	Pure components: mixing and separation	84
3.3.5	Work recovery.....	86
3.3.6	Simulation in ASPEN Plus	89
3.4	Conclusion.....	90
	References	92
	Appendix A: Thermodynamic Property Data	94
	Appendix B: Useful work of compression is equal to Isothermal Work	94
4	A Graphical Approach to flowsheet synthesis as applied to the Fischer-Tropsch system.....	96
	Abstract.....	96
4.1	Introduction	97
4.2	Theoretical development of the Graphical Technique	100
4.2.1	A Simple Process	100
4.2.2	Work Addition.....	101
4.2.3	Graphical Representation of Heat and Work.....	110
4.3	Development of a Fischer-Tropsch process flow sheet	124
4.3.1	Defining the independent material balances of the process.....	124
4.3.2	Drawing the independent balances into the GH-space	126
4.3.3	The overall Material balance	131
4.3.4	The effects of temperature and chemical equilibrium	134
4.3.5	The effect mixing and separation	147
4.3.6	Excess work recovery	152
4.4	Conclusion.....	159
	References	161
5	Overall Conclusions.....	163
5.1	Summary of Main Results	163
5.1.1	Coal Gasification.....	163
5.1.2	Methane Steam Reforming.....	164

5.1.3	Comparison of Coal Gasification and Methane Steam Reforming	164
5.1.4	Design of Fischer-Tropsch fuels using Methane Steam Reforming	165
5.2	Recommendations	167

List of Figures

Figure 2.1: Reaction or a simple process as a single point, A, on the GH-space	24
Figure 2.2: Reaction or process as a vector in the GH-space	25
Figure 2.3: Representation of compressor and turbine process on the GH-space	26
Figure 2.4: Representation of a mixing and separation process in the GH-space	27
Figure 2.5: A heat engine.....	29
Figure 2.6: A simple process	30
Figure 2.7: Effect of changing temperature on the process vector. Point A is the process at the Carnot temperature and point B is the process at a temperature below the Carnot temperature..	31
Figure 2.8: The four gasification reactions as vectors on the GH-space	36
Figure 2.9: Vector addition of the four “gasification” reactions	36
Figure 2.10: Flowsheet of a hypothetical process represented by the vector addition of Figure 2.9	37
Figure 2.11: Gasification as a simple process at the operating point A of Figure 2.9.....	38
Figure 2.12: Combining gasification and combustion into a single unit at 1200°C, showing the effect of changing temperature on the Gibbs free energy.....	39
Figure 2.13: Combine WGS and phase change at 130°C, showing the effect of temperature change on the Gibbs free energy.....	40
Figure 2.14: The overall process with the vector addition of the Gasifier and Shift units	41
Figure 2.15: Reversible gasification process under ideal conditions including net work recovery	42
Figure 2.16: Gasification process, with water recycle from water-gas equilibrium and work recovery.....	44
Figure 2.17: The overall process with the “gasifier” vector at 1200°C and “shift” vector at 130°C	45
Figure 2.18: Gasifier, vector addition of Gasification reaction and Combustion reaction, at 1200oC with ideal mixing.....	47
Figure 2.19: Shift reactor, vector addition of Phase Change reaction and WGS reaction, at 600°C with ideal mixing	47
Figure 2.20: Shift reactor at 600°C with ideal mixing and ideal separation	48
Figure 2.21: Vector addition of all reaction, mixing and separation vectors to give the overall process with WGS equilibrium, ideal mixing and ideal separation.....	49
Figure 2.22: Percentage of work recovered with changes in pressure and gasifier temperature..	50
Figure 2.23: Gasification system with separation, mixing and modified gasifier temperature	51
Figure 3.1: A simple process	59
Figure 3.2: A heat engine depicting the relationship between heat, work and temperature	61
Figure 3.3: Reaction carried out as a simple process, represented as a point in the GH-space	65
Figure 3.4: The effect of extent of reaction on the GH-space	66
Figure 3.5: The set of all combustion extents with $0 \leq e \leq 1$ as a simple process where extent is defined for 1 mole of methane	66
Figure 3.6: Effect of temperature on a simple process in the GH-space: combustion.....	67
Figure 3.7: A hypothetical complex process consisting of a methane combusting process and then a steam producing process.	68

Figure 3.8: Mass, heat and work flow for the hypothetical complex process. Mass as solid lines, heat as bold lines and work as dashed lines.....	69
Figure 3.9: The complex combustion process drawn as a simple process.....	69
Figure 3.10: Steam reforming reactions plotted with exaggerated vector angles showing the area of all possible mass, energy and work balances and thus all possible process operating points..	72
Figure 3.11: All possible steam reforming processes that produce 2:1 syngas product, shown within the overall material balance area	76
Figure 3.12: Processes meeting 2:1 specification with the extent of the reforming reaction varying between 0 and 1	76
Figure 3.13: Postulate reformer flow sheet 1 using process Carnot temperatures.....	78
Figure 3.14: Mass, Heat and Work flow for postulate flow sheet 1	79
Figure 3.15: Equilibrium extent and temperature for WGS reaction. By material balance the required $e_{WGS}=e_{reform}/3=0.26$	82
Figure 3.16: Postulated flow sheet 2 for modified operating temperatures.....	83
Figure 3.17: Combined flow sheet taking into account operating temperature and process mass integration	84
Figure 3.18: The pure component reformer unit resultant vector being added to the mixing vector	85
Figure 3.19: Postulate flow sheet 3 with the inclusion of mixing and separation	86
Figure 3.20: Near reversible steam reforming process with work recovery.....	87
Figure 3.21: Flow of heat (thick solid lines) and work (dashed lines) for Flowsheet, Figure 3.20	88
Figure 4.1: A Simple Process.....	100
Figure 4.2: A Simple Process with the required heat and work.....	101
Figure 4.3: Heat engine showing the flow of work with heat.....	102
Figure 4.4: Simple Process with Heat and Work flowing together through a "heat pump"	103
Figure 4.5: Methane Reforming as a Simple Process	104
Figure 4.6: Reversible Reforming process at its Carnot temperature	105
Figure 4.7: Compressor system with heat recovery.....	106
Figure 4.8: Simple process with compression and expansion	108
Figure 4.9: Combustion reaction as a point on the GH-space	110
Figure 4.10: The effect of extent of reaction on heat and work.....	111
Figure 4.11: The set of all combustion extents with $0 \leq e \leq 1$	112
Figure 4.12: Effect of temperature on the Combustion reaction in the GH-space showing the decrease of available work with decreasing temperature	113
Figure 4.13: Phase change represented on the GH-space as a line for $0 \leq e \leq 1$ at its Carnot temperature and atmospheric pressure.....	114
Figure 4.14: Phase Change and Combustion together on the GH-space for $0 \leq e \leq 1$	115
Figure 4.15: Combustion extent modified to produce just enough heat for an adiabatic resultant process but with excess work.....	116
Figure 4.16: Combustion extent modified to produce just enough work in the resultant process but with a deficit in heat.....	117
Figure 4.17: Mass-Flow of adiabatic steam generation using Figure 15	118
Figure 4.18: Heat and Work flow for steam generation process where the circular units represent Carnot engines	119

Figure 4.19: Modification of combustion temperature to 1000K, showing decrease in available work due to departure from combustion Carnot temperature	120
Figure 4.20: Steam generation at 250°C and Combustion at 730°C with vector addition to an overall adiabatic process with excess work to be recovered or rejected.....	121
Figure 4.21: Steam Generation Process with Compression and work recovery. From the origin to the triangle is the potential work, from origin to diamond is work recovered by compression/turbine system, origin to square is the addition of the previous two vectors.	122
Figure 4.22: Mass flow and compression for steam generation with turbine work recovery.....	123
Figure 4.23: The 5 material balances drawn onto the GH-space with $e=1$	126
Figure 4.24: The 5 balances with exaggerated positions to show a possible operating region for any combination of the independent material balances	127
Figure 4.25: Operating Region collapsed to an operating line with constraints on extent, producing the preferred ration of H ₂ :CO.....	128
Figure 4.26: Process operating line after inclusion of material balance constraints, with preferred H ₂ :CO = 2:1.....	129
Figure 4.27: First draft Process flow sheet prior to investigation of temperature effects.....	133
Figure 4.28: Second draft Process flow sheet with inclusion of operating temperature, equilibrium and recycles	141
Figure 4.29: Third draft Process flow sheet showing the combination of the Reforming, "early" Water-gas Shift and Combustion reactions.....	143
Figure 4.30: Reforming reaction vector at 1273K and $e=1$	144
Figure 4.31: Vector addition of Combustion ($e_{\text{combust}}=0.14$) and Reforming.....	144
Figure 4.32: Resultant vector for the Reformer unit, composed of the vectors for Reforming, Combustion and "early" Water-gas shift	145
Figure 4.33: Resultant vector for the overall Process. Composed of Reforming, "early" WGS, Combustion, WGS, FT synthesis and Phase change	145
Figure 4.34: Third draft Process flow sheet showing the flows of heat (solid bold lines) and work (dashed lines) between the process units	146
Figure 4.35: The Reforming reaction vector for all extents from 0 to 1 at 1000°C	147
Figure 4.36: The effect of mixing on the Reforming reaction vector	148
Figure 4.37: The Reformer resultant vector including the mixing effect for the products from Steam Reforming, Combustion and "early" WGS.....	149
Figure 4.38: The overall process resultant vector including all the reactions, mixing and separations.....	150
Figure 4.39: Fourth draft Process flow sheet including separators after syngas production and FT synthesis.....	151
Figure 4.40: Overall process resultant vector with the work recovery at 20 atm	153
Figure 4.41: Fifth draft process flow sheet including work recovery by increasing the pressure of the syngas production section to 20atm.....	154
Figure 4.42: Fifth draft flow sheet showing the flows of heat (bold lines) and the flows of work (dashed lines)	155
Figure 4.43: Sixth draft flow sheet with air separation.....	157
Figure 4.44: Sixth Draft flow sheet showing flows of heat (bold lines) and flows of work (dashed lines).....	158

List of Tables

Table 2.1: Summary of the material balances for all the process reactions.....	41
Table 3.1: Summary of lost work with increasing process complexity	90
Table 4.1: The independent material balances with the energy and work balances	125
Table 4.2: Material balance of all chemical components in terms of extent of reaction	132
Table 4.3: Independent material balances and their Carnot Temperatures.....	134
Table 4.4: Overall Component Material balance modified for equilibrium and “early’ Water-gas shift	137
Table 4.5: The process reactions and their chosen operating temperatures.....	138
Table 4.6: The energy and work balances for the process reactions with ΔG modified for temperature	139

1 Overall Introduction

1.1 The Contribution

The rapid growth of the human population and the desire to improve the standard of living of the, ever increasing, population has led to increasing demand on industries to maximize their productivity. This demand on industry has then led to an increase in the emission of Carbon Dioxide (among other things) into the atmosphere, which has had the effect of environmental degradation and the diminishing of natural resources. This has then led to another demand being placed upon industry: to minimize their environmental impact while not adversely affecting their productivity. To meet these demands new designs need to make the best use of raw materials and energy as they possibly can. This research does not suggest ceasing the use of fossil fuels but rather to attempt to get the most out of the fossil fuels that are used.

The existing procedures for process synthesis, ^{1,2,3,4,5,6} involve the selection of a product, then selecting the raw materials and reactions that can yield this product finally leading into the selection of unit operations. After these procedures have finalized the process layout, mass and energy balances are done on the process.

It was suggested, ⁷ that the most degrees of freedom in a design exist at the very beginning, during the “research/development” and the “conceptual design” stages. This implies that the greatest opportunities to innovate and improve are also most prevalent at these earliest stages of a design. As the design proceeds it only becomes more difficult to make changes, costs increase, degrees of freedom decrease and thus opportunity for innovation also decreases as design proceeds. It was also shown, ⁷ that once a plant has been put into operation it is very costly to attempt a retrofit and offers comparatively little advantage to if these options had been explored during the conceptual phase before the plant had been constructed.

An economic representation of process design has also been suggested, ⁸ which states that costs are low during conceptual design while degrees of freedom are high.

Great savings, in time and money, can be made by developing systematic techniques of conceptual design in order to get the most out of the low costs and high freedoms during this stage of design.

Methods for systematic conceptual design have been developed and include:

Hierarchical analysis, which splits a design problem into smaller manageable tasks, ^{9,10} in this methodology design decisions are taken using “rules-of-thumb” derived from engineering judgment or experience and even surveys of the literature. Systematic structures have been proposed for hierarchical analysis and include a “level based” structure, ¹¹ which can be laid out as follows:

- Level 1: Input Information
- Level 2: Flowsheet Input-Output structure
- Level 3: Recycle Structure
- Level 4: Specification of Separation System
- Level 5: Energy Integration

The “Onion Model”,¹² starts with the reactor at the center of the onion and proceeds outwards. The design of the reactor determines the layout of the separation and recycles system. All of these then determine the heat duties and heat recovery system. Utilities then compensate for heat requirements that cannot be met by the process heat recovery. Finally water and effluent treatment is considered, if required.

The weakness of the hierarchical approach is that humans are, regardless of wisdom, ultimately fallible and such an approach has a tendency to inherit the strengths and weaknesses of what came before and accomplish nothing new. Additionally the sequential nature of the design does not take into account how the individual levels or layers interact with one another this can potentially result in a locally optimal solution but not a global (or system-wide) optimum.

In addition to Hierarchical analysis there is the use of thermodynamics to establish performance targets for a process. These targets can range from minimum energy consumption to minimum heat transfer areas or minimum annual costs. These performance targets provide a basis of comparison to the “best possible” and provides a potential guideline for design.¹³

The most well known and successful use of thermodynamics in conceptual design is “pinch technology”,^{14,15,16,17,18} originally used for determination of energy targets in heat recovery the method has since been extended to mass exchangers,¹⁹ reactor synthesis,²⁰ and separation residue curve maps.²¹

The next methodology used in conceptual design in mathematical programming and optimization. Optimal process structures are found by applying optimization techniques to some objective function which is the subject of certain constraints. The mathematical formulation is then solved as a mixed integer problem.²² Mathematical formulation provides a systematic method of handling process synthesis problems and allowing many options to be considered simultaneously with alternatives becoming available quickly.²³ However this approach cannot guarantee true optimality due to certain considerations not being including in the problem statement, global optimums are also not guaranteed due to the complexity of a non-linear system,²⁴ additionally designer input is not often included in the formulations.

A great deal of existing research focuses not on the flowsheet but on the individual units within a flowsheet. Reactor sequencing,^{25,26} focuses on an optimal arrangement of reactors that will attain the desired yield of the process. Alongside this reactor sequencing studies on catalysis,^{27,28,29} attempts to individually optimize the performance of each reactor within the sequence. Following the optimization of the reactor sequence, separation sequences are then optimized,³⁰ where separation units are arranged in an optimized manner to provide the desired separation of materials and product purity. Finally heat integration is performed with an optimized layout of heat exchangers,^{31,32,33} to efficiently meet required heat duties.

What all of these techniques have in common is that they are done on a finalized process flowsheet, they also each follow on from one another in a sequential manner. Reactor sequencing and catalysis is followed by separation sequencing, which is followed by heat exchanger sequencing. The weakness of such sequential methods is that the optimization of one section can lead to heavy demands upon the following section which can then have a knock-on effect on the rest of the optimization: Reactor optimization can put severe strain on the separation system, which in turn puts strain on the exchanger network. The result is likely to be a process with a very efficient reactor system but with low efficiency in the rest of the process.

This research proposes that the greatest opportunity for process improvements is from the very outset of a design, before the flowsheet has even been finalized. It has been stated,³⁴ that 80% of the CAPEX of a design has been fixed once the flowsheet layout has been finalized. In this method the mass, energy and work balances are used to determine what the target for a process should be and then develop a process flowsheet that will attempt to meet this target. The mass, energy and work balances are used to develop a flowsheet rather than balances been done on a flowsheet.

The purpose of this work is to demonstrate a method of systematic process flowsheet *construction*, where fundamental properties of mass conservation and thermodynamics can be used to build flowsheets that can meet the increasing social and economic demands placed upon manufacturing plants and their designers, such as decreasing the environmental impact of chemical plants while also improving their productivity. This research is an application of research previously developed by the group.^{35,36} The main goal in this work is to attempt to design processes with minimum carbon emissions that also make efficient use of the heat and work available.

This does not render previous research obsolete by any stretch of the imagination. Where the research herein allows a target for a process to be determined there are still a great deal of other details that need to be considered before a functional processes could be constructed. This research allows for the construction of a process flowsheet, existing research could then pick up this flowsheet and use it as a basis for further optimizations.

1.2 The Method

This method of flowsheet construction uses a graphical tool called the GH-space. It is a plot of Enthalpy against Gibbs-Free energy, which is representative of heat and work flows of a process respectively. The GH-space is a plot of two extensive properties, both of which are independent of one another. The principles applied in the GH-space may appear to be simple thermodynamics but this can be somewhat deceptive, the GH-space uses such simple principles to provide an elegant method of building flowsheets.

The central idea of the GH-space is that any unit process that can have their change in enthalpy and Gibbs-free energy defined (this actually includes *all* unit processes, since all units can have mass, energy and entropy balances performed on them) can be represented as vectors on the GH-space and can be manipulated as vectors where the change in enthalpy represents the flow of heat

and the change in Gibbs-free energy represents the flow of work. By applying design targets to the vectors on the GH-space, a flowsheet can be constructed that meets these targets while also minimizing the emissions and making the best of the heat and work available in the process.

One of the primary methods of determining how successful the use of the GH-space has been is to use the “Carbon Efficiency”. The Carbon Efficiency of a process is defined as the amount of carbon atoms that are in the desired product over the number of carbon atoms present in the primary carbon containing raw material feed. In this paper there are two primary carbon containing raw material feeds, Coal (pure carbon) and Natural Gas (methane). So in this paper the Carbon Efficiency is the number of carbon atoms in the desired product over the number of carbon atoms in the Coal or Natural Gas feed.

It should be noted that this work is presented in the form of a series of papers. As such, there will be some repetition especially in regards to the “theoretical development” (Sections 2.2, 3.2 and 4.2) of the thermodynamics used in the GH-space. If desired, each of the three papers can be read independently of each other.

In Chapter 2 the GH-space is applied to the production of synthesis gas from coal (gasification), which is assumed to be carbon. The gasification process is arranged into four independent material balances which are manipulated as vectors on the GH-space by modifying the extent of reaction and temperature. By defining a target for the process these variables can be manipulated to formulate a flowsheet that achieves the desired target and provides insight into how heat and work interact within the process.

In Chapter 3 the GH-space is applied to the production of synthesis gas from natural gas (methane steam reforming), which is assumed to be methane. As in Chapter 2 the process is arranged to four independent material balances and vector manipulations are performed upon them in order to meet the targets defined for the process. The goal here was to investigate the differences between the uses coal and natural gas, if given a choice between the two, to generate synthesis gas in terms of the efficiency of heat and work integration and carbon dioxide emissions.

In Chapter 4, with the results of the previous two Chapters in mind, Fischer-Tropsch synthesis is then added to the production of synthesis. Fischer-Tropsch synthesis of hydrocarbon fuels was added as a fifth independent material balance to the process formulation. As before vector manipulations were performed with the goal of taking full advantage of energy and work integration as well as minimizing carbon dioxide emissions. The formulation of this flowsheet also provided insight into the kind of effects additional complexity would have on the previous flowsheet designs.

Chapter 5 then provides the overall conclusions to the three flowsheet designs and the insights gained from them before going on to make recommendations for the continued development of the research

References

1. Mahalec, V. and Motard, R. L. (1977) Procedures for the Initial Design of Chemical Processing Systems. *Computers and Chemical Engineering*. **1**(1), 57-68
2. Westerberg, A.W. (2004) A Retrospective on Design and Process Synthesis. *Computers and Chemical Engineering*. **28**(4), 447-458
3. F. Friedler. Process Integration, Modelling and Optimisation for Energy Saving and Pollution Reduction, *Applied Thermal Engineering* (2010), doi: 10.1016/j.applthermaleng.2010.04.030
4. Damartzis, T. and Zabaniotou, A. (2011) Thermochemical conversion of Biomass to second generation Biofuels through integrated process design-A review. *Renewable and Sustainable Energy Reviews*. **15** (8), 366-378
5. Abdul Hossain, K., Khan, F.,Hawboldt, K. (2010) SusDesign – An approach for sustainable process system design and its application to thermal power plant. *Applied Thermal Engineering*. **30** (14-15), 1896-1913
6. Diwekar, U., Shastri, Y. (2011) Design for environment: A state-of-the-art review. *Clean Technologies and Environmental Policies*. **13**(2), 227-240
7. Yang, Y. and Shi, L. (2000) Integrating environmental impact minimization into conceptual chemical process design – A process system engineering review. *Computers and Chemical Engineering*. **24**(2-7), 1409-1419
8. Korevaar, G., 2004, Sustainable Chemical Processes and Products. Thesis, (PhD), Delft University of Technology
9. Hendry, J. E., Rudd, D. F., Seader, J. D. (1973) Synthesis in the design of Chemical Processes. *AIChE Journal*. **19**(1), 1-15
10. Barnicki, S. D. and Siirola, J.J. (2004) Process Synthesis Prospective. *Computers and Chemical Engineering*. **28**(4), 441-446
11. Douglas, J. M. (1985) A Hierarchical Decision procedure for Process Synthesis. *AIChE Journal*. **31**(3), 353-362
12. Smith, R. and Linnhoff, B. (1988) The design of separators in the context of overall processes. *Chem. Eng. Res. Des.* **66**, 195-288
13. Gundersen, T. A Process Integration PRIMER, SINTEF energy research, Trondheim, Norway, May 2000
14. Linnhoff, B. and Flower, J. R. (1978) Synthesis of heat exchanger networks I: Systematic generation of energy optimal networks. *AIChE Journal*. **24**(4), 633-642

15. Linnhoff, B. and Flower, J. R. (1978) Synthesis of heat exchanger networks II: Evolutionary generation of networks with various criteria for optimality. *AIChE Journal*. **24**(4), 642-654
16. Krummenacher, P. and Favrat, D. (2010) Indirect and Mixed Direct-Indirect Heat Integration of Batch Processes based on Pinch Analysis. *International Journal of Thermodynamics*. **4**(3), 135-143
17. Harkin, T., Hoadley, A., Hooper, B. (2010) Reducing the Energy Penalty of CO₂ capture and compression using pinch analysis. *Journal of Cleaner Production*. **18**(9), 857-866
18. Domenichini, R., Gallio, M., Lazzaretto, A. (2010) Combined production of hydrogen and power from heavy oil gasification : Pinch Analysis, thermodynamic and economic evaluations. *Energy*. **35**(5), 2184-2193
19. El-Halwagi, M.M. and Manousiouthakis, V. (1989) Synthesis of Mass Exchange Networks. *AIChE Journal*. **35** (8), 1233-1244
20. Hildebrandt, D., Glasser, D., Crowe, C. (1990) The geometry of the attainable region generated by reaction and mixing with and without constraints. *Ind. Eng. Chem. Res.* **29**(1), 49-58
21. Doherty, M. F., Malone, M. F. 2001, *Conceptual design of distillation systems*, McGraw Hill, New York
22. Grossmann, I. E., Caballero, J. A., Yeomans, H. (2000) Advances in mathematical programming for the synthesis of process systems. *Latin American Applied Research*. **30**(4), 263-284
23. Smith, R. 2005, *Chemical Process Design and Integration*, John Wiley & Sons, West Sussex
24. Kravanja, Z. and Grossmann, E. (1997) Multilevel-hierarchical MINLP synthesis of process flowsheets. *Computers and Chemical Engineering*. **21**(1), s241-s246
25. Floudas, C. A and Kokossis, A. C. (1990) Optimization of Complex Reactor Networks-I. Isothermal Operation. *Chemical Engineering Science*. **45**(3), 595-614
26. Floudas, C. A. and Kokossis, A. C. (1994) Optimization of Complex Reactor Networks-II. Non-Isothermal Operation. *Chemical Engineering Science*. **49** (7), 1037-1051
27. Shadel, B.C., Duisberg, M., Deutschmann, O. (2009) Steam Reforming of Methane, Ethane, Propane, Butane and Natural Gas over a Rhodium based catalyst. *Catalysis Today*. **42** (1-2), 42-51
28. Escritori, J.C., Dantas, S.C., Soares, R.R., Hori, C.E. (2009) Methane Autothermal Reforming on nickel-ceria-zirconia based catalysts. *Catalysis Today*. **10** (7), 1090-1094

29. Wu, P., Li, X., Ji, S., Lang, B., Habimana, F., Li, C. (2009) Steam Reforming of Methane to Hydrogen over Ni-based metal monolith catalysts. *Catalysis Today*. **146** (1-2), 82-86
30. Floudas, C. A. and Anastasiadis, S.H. (1988) Synthesis of distillation sequences with several multicomponent feed and product streams. *Chemical Engineering Science*. **43**(9), 2407-2419
31. Kokossis, A.C. and Briones, V. (1999) Hypertargets: A Conceptual Programming approach for the optimisation of industrial heat exchanger networks-I. Grassroots design and network complexity. *Chemical Engineering Science*. **54** (4), 519-539
32. Kokossis, A.C. and Briones, V. (1999) Hypertargets: A Conceptual Programming approach for the optimisation of industrial heat exchanger networks-II. Retrofit Design. *Chemical Engineering Science*. **54** (4), 541-561
33. Kokossis, A.C. and Briones, V. (1999) Hypertargets: A Conceptual Programming approach for the optimisation of industrial heat exchanger networks-III. Industrial Applications. *Chemical Engineering Science*. **54** (5), 685-706
34. Biegler, L.T., Grossmann, I.E., Westerberg, A.W. 1997, *Systematic methods of Chemical Process Design*, Prentice Hall, New Jersey
35. Patel, B., 2007, Fundamental Targets for the synthesis and evaluation of chemical processes. Thesis, (PhD), University of the Witwatersrand
36. Sempuga, B.C., 2011, A Graphical Approach to Analyze Processes using Thermodynamics. Thesis, (PhD), University of the Witwatersrand

2 A Graphical Approach to Synthesizing Flowsheets: Application to Gasification

Abstract

Thermodynamics can be used to describe any process, or system of processes. Of particular interest are the properties of enthalpy and Gibbs free energy. By using these two thermodynamic properties together as vectors on a diagram of free energy (ΔG) against enthalpy (ΔH), it becomes possible to develop better process flow sheets that combine the thermodynamics of chemical reactions and the dynamics of physical operations on a single diagram. This concept is also explored in a paper by Sempuga¹

By selecting appropriate operating conditions for a process, such as temperature, pressure and reaction extent, it is possible to find on this “GH-space” the combination of reactions and operations that will allow the process, in its entirety, to *potentially* be run reversibly, that is, the change in entropy of the universe will be in the limit zero. This would thus allow a flow sheet to be developed that would represent the process performing at its highest efficiency.

Such a flowsheet can provide an important basis for allowing new processes to be developed to minimize their impact on the environment and maximize their productivity. The flowsheet can also provide a means of identifying the inefficiencies of existing processes and provide a basis for improvement.

The operation of a gasifier is considered in this paper to illustrate the use of the G-H diagram. The primary reaction is the gasification of coal. To provide the heat and work that gasification requires coal is also burned in oxygen or air. The water-gas-shift reaction is also considered to allow the ratio of carbon monoxide and hydrogen to be adjusted to the desired specification. The phase change of liquid water to its vapour phase is also considered which allows for the use of liquid water as a starting feedstock.

Using these ideas one is able to show how to improve the carbon and operating efficiency of a gasification process, making the process more reversible.

2.1 Introduction

The impact of industries on the environment is rapidly becoming a major international concern. The demand for industries to minimize their environmental impact, as well as maximizing their productivity, is continually increasing.

Rosen and Dincer¹ described how excess work and heat will be lost as irreversibility in a system, if not recovered. They describe this loss in terms of exergy, which they define as a measure of the departure of the systems from equilibrium with its environment. It is therefore a measure of a systems ability to affect its environment; it shows the connection of losses in work and heat with environmental impact.

It has been the practice in chemical engineering to optimize processes one unit, or a network of units, at a time. This is evident in the heat exchanger network optimization work by Kokossis^{2,3,4}; the reactor sequence optimization work by Floudas and Kokossis^{5,6}; and the distillation sequence work of Floudas⁷.

In papers by Mahalec and Motard⁸ and Westerberg⁹ the procedures for process synthesis are first to consider the desired products, then the selection of raw materials and the reactions that will give the desired products, which then leads to the selection of the required unit operations. Only then are the flows of work and heat considered.

This practice of sequential design may improve the operation of that individual unit but the effect of that unit's new operation on all the other units in the process is often not considered until the time comes for those units to be optimized. This can lead later to difficulties, with optimizing requiring modifications that are impossible to perform, further leading to a process that has a few efficient units but is overall inefficient.

Although the optimization of individual units and networks is extremely important, it is proposed that a better approach to efficient process optimization and design is first to consider how all the process units integrate with one another, facilitating the creation of a process that is, *in its entirety*, efficient and optimal. Beginning from this fundamental viewpoint, this process could be the basis for the optimization of the individual units, the design of new facilities, or a guide to show where existing processes can best be improved.

In this paper the thermodynamic properties enthalpy (ΔH) and Gibbs free-energy (ΔG) are applied to the gasification process as well as to other unit operations such as compression and separation, with the goal of creating a gasification system that is as close to reversible as possible, and therefore having minimal environmental impact.

The technique described in this paper allows processes to be constructed from fundamental thermodynamic principles and basic material balances alone. While many of these principles may appear to be simple, this is actually deceptive. The technique herein is actually a very subtle, but elegant, method for designing process layouts.

The gasification process is an example that is used to demonstrate and explain the methods used in this paper. However, the approach is general and can be applied to any process.

2.2 The enthalpy, Gibbs free energy plane: the GH-space

In a paper presented by Sempuga¹⁰ it was proposed that the ΔG and ΔH of reactions and process units could be drawn on a plot of ΔG and ΔH , hereafter referred to as the GH-space.

ΔG and ΔH are both extensive properties that are calculated independently of one another. This is different from, for instance, pinch diagrams where an extensive property is plotted against intensive property. ΔS could be used instead ΔG but the latter is used in this paper due to its easier relation to work.

Similar work was done by Oaki and Ishida¹¹ who instead used plots of $T_0\Delta S$ and ΔH . The goal of minimizing the loss of work in that approach would be to minimize the value of the change in entropy. This is likely to provide a very sensitive measure of process reversibility but does not provide easy access to the practical considerations of pressure, separation, mixing and other similar considerations. The approach of using the GH-space allows all simple unit operations or reactions, for which ΔG and ΔH can be calculated, to be easily represented on a single set of axes. ΔG and ΔH are also directly related to the work and heat requirements of a process, ΔG is the work requirements of a process and ΔH is the heat requirement.

To begin, the methods of calculating ΔG and ΔH for reaction, compression and mixing/separation are presented, before being applied to the GH-space. Equations that describe other unit processes can be used and applied to the GH-space.

2.2.1 Reactions

A simple process is one where the reactants enter the process at 25°C and 1atm; the chemical transformations happen at a temperature T; and the products of the process then leave at 25°C and 1 atm.

Assume there is a simple process that can be represented as a single reaction. The difference between a simple process and a reaction is that a reaction can be represented on its own but a simple process could contain many individual reactions. In some cases “process” and “reaction” can be used interchangeably, for instance where the simple process contains only one reaction.

Also assume, for the purposes of this discussion, that the feed and products enter and leave as pure components. This assumption is relaxed later with the consideration of mixing.

The material balance of this simple process, or reaction, can be described by:

$$\sum_i \nu_i M_{i,products} - \sum_i \nu_i M_{i,reactants} = 0 \quad [1]$$

Where:

- ν_i is the stoichiometric coefficient in the component i .
- The subscript i represents species i
- M is the mass of component i

The change in Gibbs-free energy and the change in enthalpy of simple processes or reactions can be calculated using the following well-known equations:

$$\frac{\Delta G_{process}^0}{N} = \left(\sum_i \nu_i \Delta G_{f,i}^0 \right)_{products} - \left(\sum_i \nu_i \Delta G_{f,i}^0 \right)_{reactants} \quad [2]$$

$$\frac{\Delta H_{process}^0}{N} = \left(\sum_i \nu_i \Delta H_{f,i}^0 \right)_{products} - \left(\sum_i \nu_i \Delta H_{f,i}^0 \right)_{reactants} \quad [3]$$

Where:

- ν_i is the stoichiometric coefficient in the component i .
- The subscript f represents “of formation”
- The superscript 0 represents standard conditions.
- The subscript i represents species i

The temperature dependence of ΔH is small in comparison to the heats of reaction, even for large temperature differences. For the sake of clarity this temperature dependence has been neglected for this paper. It is entirely possible to include this dependence if desired but its effect on the results is almost non-existent.

By applying Equations [2] and [3] to a reaction, or simple process, the ΔG and ΔH for the reaction/process can be plotted on the GH-space. This allows any reaction to be represented as a single point, illustrated in Figure 2.1 by the point A.

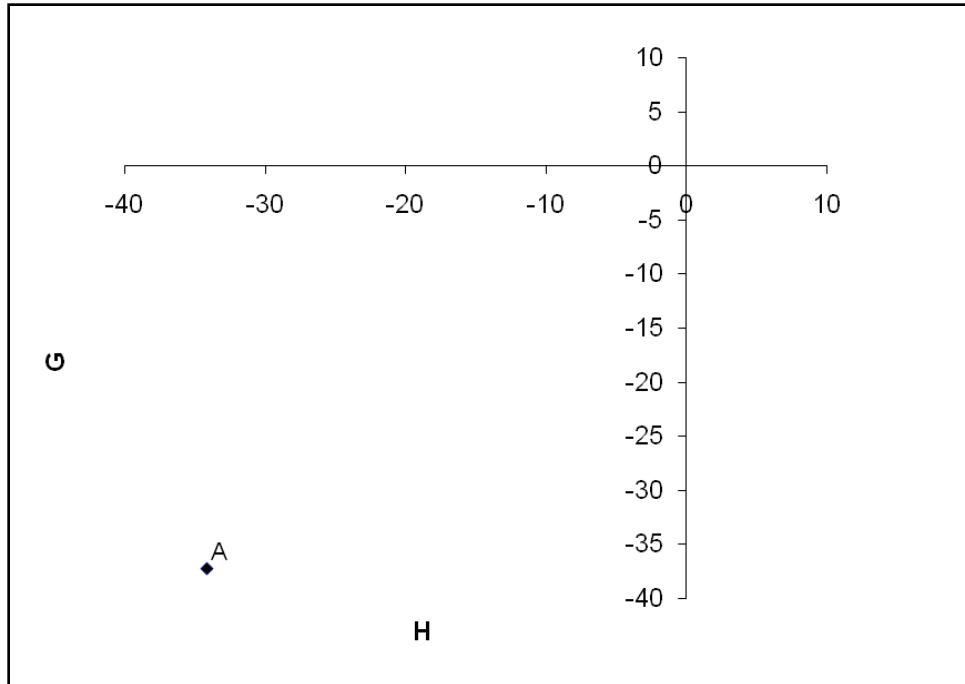

Figure 2.1: Reaction or a simple process as a single point, A, on the GH-space

Further to the principle presented by Sempuga¹⁰ and Oaki and Ishida¹¹, if the amount of material passing through the process/reaction is allowed to vary, the process/reaction can be represented as a vector beginning at the origin of the GH-space and passing through the point calculated using Equations [2] and [3], which is illustrated in Figure 2.2.

Point A depends on the quantity of material that is being converted and on the description by the material balance given by Equation [1]. The magnitude of this reaction vector depends on the extent of the reaction. Where the extent of reaction, e , is the amount of a reactant that is converted in the reaction.

Consider as an example the combustion of carbon in oxygen, that is $C+O_2 \rightarrow CO_2$. If 1 mole of carbon were reacted with 1 mole of oxygen, and they reacted to form 1 mole of carbon dioxide then the reaction proceeded to completion, and the extent of reaction, e , would be 1. If only 0.8 moles of oxygen were added instead, then the combustion could proceed to $e = 0.8$, which still corresponds to completion, since the oxygen now limits the reaction. Extents of reaction over 1 can be obtained by reacting more than the stoichiometric amounts, as described by material balance Equation [1], of the reactants.

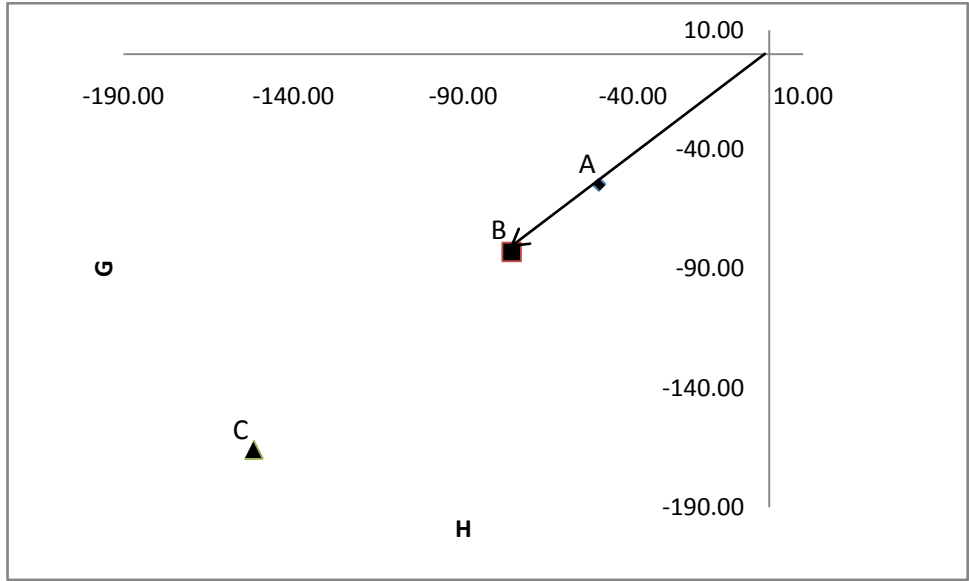

Figure 2.2: Reaction or process as a vector in the GH-space

Figure 2.2 illustrates the reaction/process as a vector in the GH-space. If the reaction does not occur at all ΔG and ΔH would be zero. Therefore the vector describing the change in G and H across the process would be 0 which corresponds to the origin. If the reaction were to proceed to an extent of $1/3$, the vector would terminate at the point A; if the reaction were to have an extent of $1/2$, the vector would terminate at point B; and similarly at point C if the extent were 1.

2.2.2 Compression

Consider the net work that is used to reversibly compress an ideal gas from pressure P_0 and temperature T_0 to pressure P and temperature T . If the compression were done adiabatically, for example, by recovering the heat generated by the adiabatic compression, with a heat engine, the net work that is supplied to the gas would correspond to the work that is required for an isothermal compression. This means that the work that is actually used to increase the pressure is equivalent to the isothermal work requirements. The additional work used in adiabatic compression is transformed into heat, which increases temperature, which does not contribute to increasing the pressure and is lost unless recovered from the heat of the exiting stream.

For the case of isothermal compression of an ideal gas the ΔG of the compression can be shown to be:

$$\frac{\Delta G_{compression}}{(n_{in} - n_{out})} = RT \ln\left(\frac{P}{P^0}\right) \tag{4}$$

Where:

- n is the moles of gas entering (in) or leaving (out) the process
- R is the universal gas constant
- T is the compression temperature in Kelvin
- P and P^0 are the final and initial pressures

There is no ΔH associated with an isothermal compression of an ideal gas, which is to say $\Delta H_{\text{compression}} = 0$.

Also note the gas mole terms in Equation [4] does not represent a mass change across a single compressor or turbine. It represents the change in gas moles across the entire process. In other words, the work required to compress the gas entering the process is not necessarily the same as the work gained from decompressing the gas leaving the process. The work gained from the turbine at the exit from the process can be used to run the compressor at the entry to the process. Equation [4] allows the calculation of any excess or deficiency in the work from an integrated compressor/turbine system over the entire process.

It is now possible to draw, on the GH-space, the $\Delta G_{\text{compression}}$ and $\Delta H_{\text{compression}}$. Similarly to the case for reaction, the compression process can be represented as a vector on the GH-space.

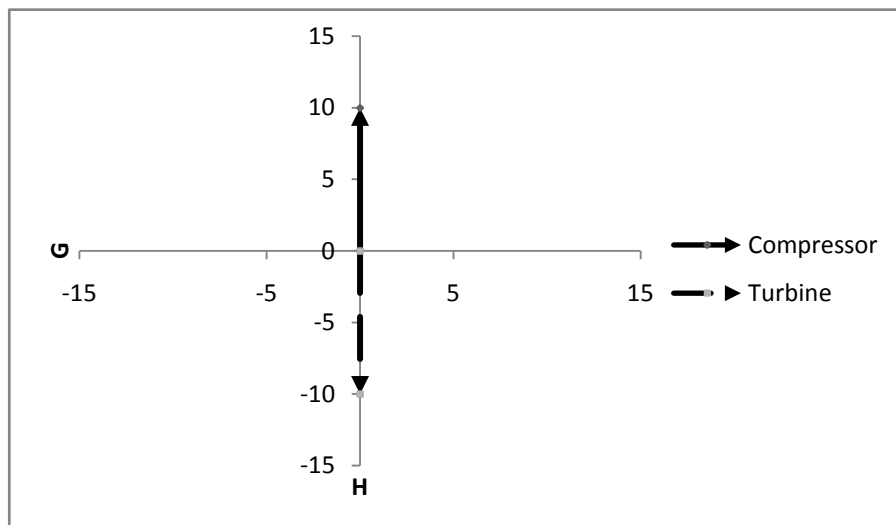

Figure 2.3: Representation of compressor and turbine process on the GH-space

The magnitude of this vector depends on the compression pressure and the difference in the number of moles leaving and entering the compression process. The direction of the vector also depends on whether more gas leaves or enters the system, or whether the pressure of the exit stream is higher or lower than the inlet pressure. So it is possible to describe either a compressor (where $\Delta G > 0$) or a turbine system (where $\Delta G < 0$). Figure 2.3 shows a compressor with its direction upwards and the turbine with its direction downwards.

2.2.3 Mixing and separation

Consider where N_i moles of pure components i are mixed. For the situation of ideal mixing $\Delta H_{\text{mix}} = 0$ and the ΔG of mixing, ΔG_{mix} , is given by:

$$\frac{\Delta G_{\text{mix}}}{N} = RT \left(\sum_i x_i \ln x_i \right) \quad [5]$$

Where:

- N is the molar flow rate after mixing. $N = \sum N_i$
- R is the universal gas constant
- T is the mixing Temperature
- x is the mole fraction of component i

Similarly to the case of compression, mixing is represented by a vector on the GH-space with a magnitude defined by the mole fractions of the components, the total molar flow rate of the mixed stream N , and the temperature. The direction of the vector depends on whether mixing or separation is desired, where a mixing process corresponds to $\Delta G_{\text{mix}} \leq 0$ and a separation process corresponds to $\Delta G_{\text{mix}} \geq 0$. This is illustrated by Figure 2.4.

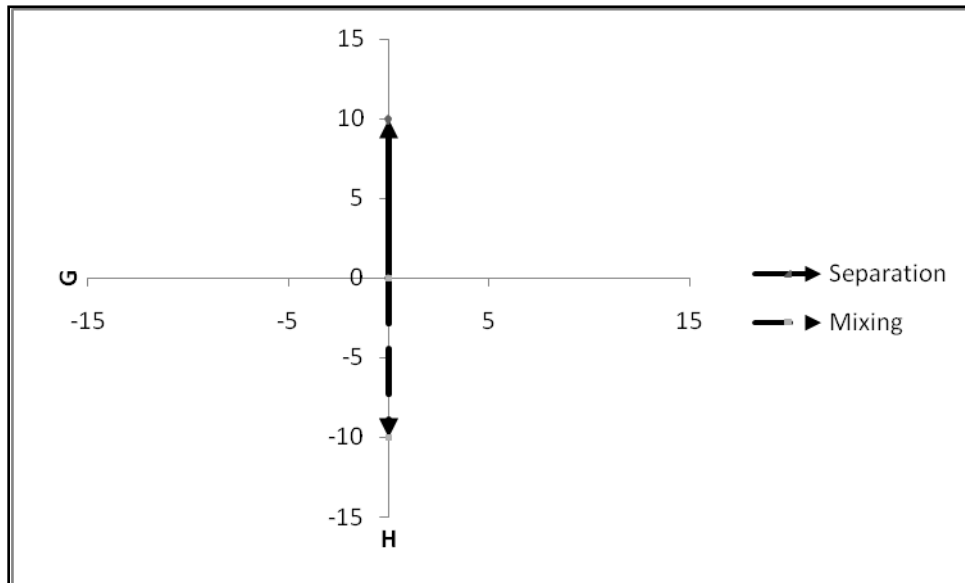

Figure 2.4: Representation of a mixing and separation process in the GH-space

In the case of non-ideal mixing ΔH_{mix} is not zero and ΔG will be affected by the fugacities of the components in the mixture. As long as ΔH and ΔG can be defined, mixing and separation can be represented as vectors in the GH-space.

2.2.4 Vector addition

As shown in the previous sections reactions and unit operations can be represented as vectors on the GH-space. The interaction between various reactions and other unit operations can be shown by the use of vector addition.

So a reaction process, represented by the vector

$$\begin{pmatrix} H_{reaction} \\ G_{reaction} \end{pmatrix}$$

followed by a compression process, for instance, represented by the vector

$$\begin{pmatrix} H_{compression} \\ G_{compression} \end{pmatrix}$$

would be represented together on the GH-space by the resultant vector

$$\begin{pmatrix} H_{reaction} + H_{compression} \\ G_{reaction} + G_{compression} \end{pmatrix}$$

2.2.5 Heat and work

When the material enters and leaves a process at ambient temperature T_0 , the change in Gibbs free energy across the process $\Delta G_{process}$ represents the maximum amount of work required or obtainable from the process. This would correspond to either the maximum amount of work that could be recovered from a reversible process with the same inputs and outputs of a real process, or to the minimum amount of work that would need to be input to a reversible process with the same inputs and outputs of a real process.

As shown by Patel, *et al*¹²

$$dW = VdP \quad \text{and} \quad dG = -SdT + VdP$$

thus

$$W = \int VdP = \int dG$$

$$\Delta G_{process} = W$$

In real processes, where work is recovered $W_{real} < W_{ideal}$, or where work is added then $W_{real} > W_{ideal}$

Similarly, ΔH across the process $\Delta H_{process}$ represents the quantity of heat Q that is either released or required by the process. $\Delta H_{process} = Q$.

A quantity of heat $Q = \Delta H$ at a certain temperature T , has the potential to produce a quantity of work W in a reversible process. Where:

$$W = \Delta H \left(1 - \frac{T_o}{T} \right) \quad [6]$$

Where:

- W is the Carnot work associated with the amount of heat $\Delta H=Q$
- ΔH is the amount of heat Q
- T_o is the ambient temperature
- T is the temperature at which the heat is supplied

The Carnot equation is used extensively in the description of reversible heat engines, as shown in Figure 2.5.

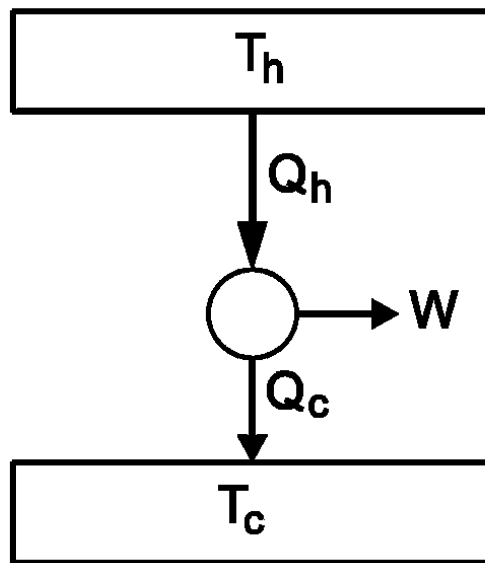

Figure 2.5: A heat engine

Consider a simple process as presented by Sempuga¹ and Patel¹³, illustrated in Figure 2.6.

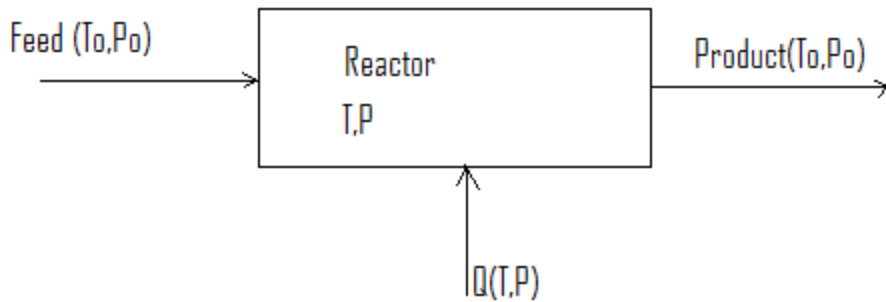

Figure 2.6: A simple process

Figure 2.6 shows the process feed entering the process at ambient conditions and leaving the process as product, also at ambient conditions. The heat required by the process is supplied to the reactor at the reaction temperature, T .

It is possible for the Carnot work, associated with the heat Q , to be exactly equal to the ΔG of a process, $\Delta G_{\text{process}}$. This will happen at a specific value of T , which is called the Carnot temperature of the process.

If a simple process were to be operated reversibly at this Carnot temperature, all the work, needed or released by a process, could be carried with the heat of the process. That is, if a process were to be operated at the Carnot temperature, it could be run reversibly as a heat engine.

The importance of the Carnot temperature is that it is the temperature at which the heat required by the process exactly matches the work required by the process (in the case of exothermic, work producing processes, signs can be adjusted accordingly). Carrying the work with the heat is the simplest and most practical way to transfer work since the other methods (compression and mixing) can transfer only small amounts of work *in comparison* to what can be carried by the heat, thus requiring extreme conditions in separations and compression. In some cases this work deficit could not be supplied by compression or separation at all.

However, often the Carnot temperature is impractical, sometimes being negative (in Kelvins) or too high or low beyond the limits of available materials. For instance, in a situation where the ΔG and ΔH of a process are very similar, the Carnot temperature will approach infinity, which occurs in the combustion of fossil fuels. For situations where ΔG is larger than ΔH the Carnot temperature will be below absolute zero.

Clearly other real temperatures must be used to add (or reject) heat to the process. If a process operating at its Carnot temperature is reversible, then operating at any other temperature will introduce a certain amount of irreversibility, unless processes are designed to take this into account. More specifically, operating above the process Carnot temperature for an endothermic process represents too much work being added to the process by the heat, whereas operating below the process Carnot temperature for an endothermic process represents too little work being added to the system by the heat. This excess or deficiency in the work needs to be recovered, or added, from the process by some other means. This is accomplished by using other reactions

(and producing other products, for example) or other unit operations (such as compression). The resulting increase in process complexity represents a process that is no longer simple.

In terms of the GH-space, operating at a temperature that is not the process Carnot temperature means that the $\Delta H_{\text{process}}$ as defined by Equation [3] will remain unchanged. $\Delta H_{\text{process}}$ is a constant with temperature since the definition of a simple process has the process feed and products at the same temperature. The heat capacities for gases are also all very similar, making $\Delta H_{\text{process}}$ a weak function of temperature. However, $\Delta G_{\text{process}}$ will not have the value given by Equation [2]. Instead the value of ΔH given by Equation [3] can be used with the desired operating temperature in Equation [6] to give the ΔG of the process at that temperature.

$$W = \Delta G_{\text{process}} = \Delta H_{\text{process}} \left(1 - \frac{T_o}{T} \right)$$

It is important to notice how the equation that is typically used to predict how chemical equilibrium changes with temperature, also describes the work flows in a process and how the work that a process can reject (or absorb as the case may be) changes as the temperature at which the heat is rejected, changes. The geometrical interpretation of this concept is illustrated in Figure 2.7

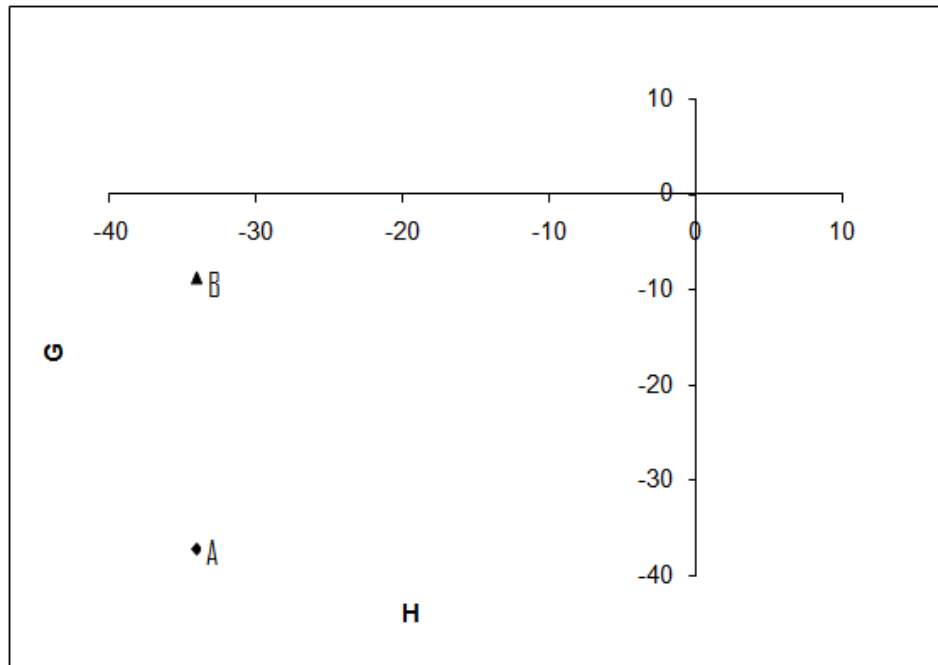

Figure 2.7: Effect of changing temperature on the process vector. Point A is the process at the Carnot temperature and point B is the process at a temperature below the Carnot temperature

Figure 2.7 shows how point A, representing the same point A of Figure 2.1, is shifted up to point B, at constant enthalpy, by decreasing the temperature at which the heat is rejected and therefore the temperature of the reaction.

The constant enthalpy with change in temperature is true for the case of the reactants and products being at the same temperature or if the heat capacities of reactant and product are similar, which is often true of systems.

The enthalpy of point B is the same as that calculated by Equation [3], the Gibbs free energy of point B is calculated by:

$$\Delta G = \Delta H \left(1 - \frac{T_o}{T}\right)$$

Where T is the desired reaction temperature.

The difference in Gibbs free energy between points A and B represents the deficit in recoverable work of the reaction as a result of decreasing the temperature below the process Carnot temperature.

An alternative interpretation of Equation [6] is that the Carnot equation is a straight line on the GH-space that has a gradient that depends on the temperature chosen. It would be possible to draw a temperature scale on the GH-space, if desired¹.

2.3 Application to gasification

2.3.1 The reactions in gasification and the overall material balance

To illustrate the use of the ΔG - ΔH plot, consider the gasification process. Before one can begin using the GH-space in designing a gasification flowsheet it would be convenient to first define the independent material balances or reactions in gasification that will be used throughout the flowsheet synthesis.

The feed species to this gasification process will be considered to be coal, which will be represented as pure carbon C, liquid water and oxygen. For this simplified case the products will be considered to be carbon monoxide, hydrogen and carbon dioxide. There will be four independent material balances that describe the system.

The primary reaction in gasification is:



The heat and work requirements for Reaction [1] can be determined by applying Equations [2] and [3]:

$$\Delta G_1 = 91.37 \text{ kJ/mol}$$

$$\Delta H_1 = 131.32 \text{ kJ/mol}$$

This reaction is endothermic and work deficient; in other words, both heat and work must be added to the process. This means a source of heat and work is required in order for the reaction to proceed. Application of Equation [6] shows that Reaction [1] has a Carnot Temperature of 707°C.

Therefore, if Reaction [1] were operated at 707°C and 131.32 kJ/mol of heat was added at that temperature, then all the required work would enter the process with the heat and it would be *potentially* reversible. However, this may not be reasonable for gasification as it usually requires higher temperatures.

A heat source is required to provide heat to the system. The most convenient source of heat would come from combusting some of the carbon feedstock (coal) in oxygen (or air) to produce the heat. This occurs by the following reaction:



Applying Equations [2] and [3] to Reaction [2] gives:

$$\Delta G_2 = -394.36 \text{ kJ/mol}$$

$$\Delta H_2 = -393.51 \text{ kJ/mol}$$

This reaction is exothermic and work producing. This will allow Reaction [2] to be used to provide the heat and work to Reaction [1]. In fact, burning a unit of coal via Reaction [2] will provide too much heat and work for gasifying a unit of coal via Reaction [1]. Having such an

excess will cause the process to become irreversible if the excess work is not recovered. Equation [6] shows Reaction [2] to have a Carnot temperature of -140000°C . This is a physically impossible temperature; *Reaction [2] cannot be run reversibly on its own*. It should be noted that most combustion reactions have similarly infeasible Carnot temperatures, meaning combustion is irreversible by its very nature. Combustion is responsible for most irreversibilities in processes.

The ratio of carbon monoxide to hydrogen resulting from Reaction [1] is 1:1. It may be desired to produce a ratio of carbon monoxide and hydrogen that is not 1:1. Ratios of 1:2 are often favored by coal-to-liquids processes and methanol processes; and ratios of 1:3 are favored by ammonia processes. Higher or lower ratios may be desired depending on the intended application.

To modify the ratio of carbon monoxide to hydrogen another reaction is required, namely the water-gas shift reaction:



Equations [2] and [3] gives the heat and work requirements:

$$\Delta G_3 = -28.59 \text{kJ} / \text{mol}$$

$$\Delta H_3 = -41.19 \text{kJ} / \text{mol}$$

This water-gas shift reaction is also an exothermic work producer with a Carnot temperature of 700°C .

So if Reaction [3] were run at 700°C , removing the excess heat of the reaction would also remove the excess work and the process would be reversible.

Performing Reaction [3] on a unit of carbon monoxide (ie. to completion) would result in all the carbon monoxide of Reaction [1] reacting to form carbon dioxide and hydrogen. That may be desirable for a hydrogen process but the desired product, for this paper, is synthesis gas. The production of only carbon dioxide and hydrogen may not be possible since the equilibrium of Reaction [3] does not strongly favor the products.

When a carbon monoxide to hydrogen ratio of 1:2 is desired, the extent of Reaction [3] with respect to Reaction [1] can be calculated by a material balance:

$$2\text{CO} = \text{H}_2$$

$$2(e_1 - e_3) = (e_1 + e_3) \quad [7]$$

$$e_3 = \frac{1}{3}e_1$$

Where e_i is the extent of reaction i . This means that, for a 1:2 CO:H₂ ratio, the extent of Reaction [3] must *always* be one-third the extent of Reaction [1].

Using an extent of one-third for Reaction [3], the ΔG and ΔH can be recalculated by dividing ΔG_3 and ΔH_3 by 3. This will have the effect of shortening the vector, as discussed previously and illustrated in Figure 2.2.

Reaction [1] and Reaction [3] use vapor phase water as a reactant. At ambient conditions liquid water is easily obtained. The phase change needs to be considered.



Equations [2] and [3] gives:

$$\Delta G_4 = 8.56 \text{kJ} / \text{mol}$$

$$\Delta H_4 = 44.01 \text{kJ} / \text{mol}$$

Reaction [4] is an endothermic and work deficient process with a Carnot temperature of 97°C.

Four reactions/simple processes have been defined and it is clear that all four of them could be integrated to interact with one another. By using the GH-space it will be possible to investigate how the reactions interact with one another and to make the process more reversible despite Reaction [2] being shown to be highly irreversible.

2.3.2 Application to the GH-space

The synthesis of flowsheets using this method is best accomplished by beginning with the simplest systems and gradually adding complexity. Each increase in complexity contains an important result that aids in the synthesis choices for the next iteration.

2.3.2.1 Phase one: A hypothetical process

Having defined all the reactions in gasification it is now possible to move into the GH-space. The four reactions are drawn onto the GH-space as presented in Figure 2.8:

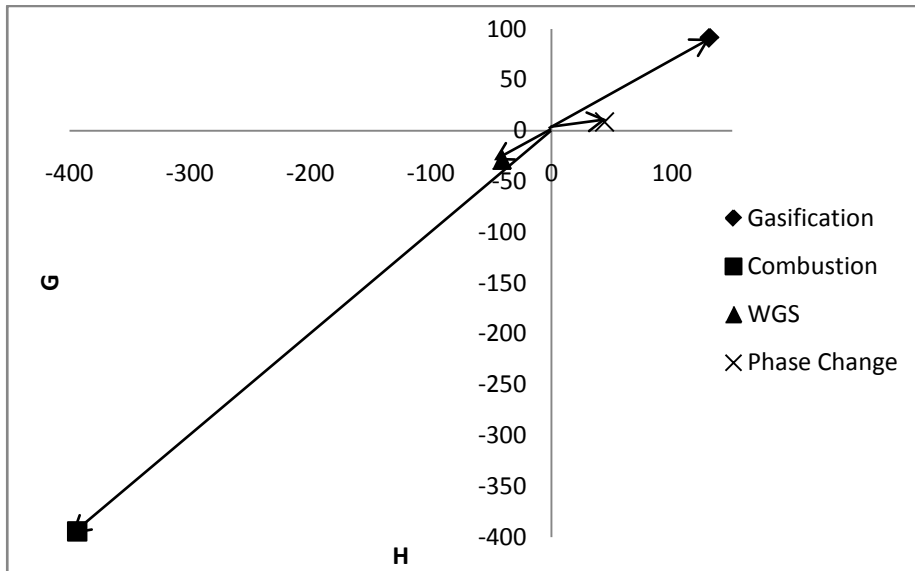

Figure 2.8: The four gasification reactions as vectors on the GH-space

As discussed in Section 2.2.1 above, the vectors terminate depending on the extent of reaction. Figure 2.8 is drawn such that Reactions [1], [2] and [4] proceed to completion and Reaction [3] is one-third the extent of Reaction [1], as required by the material balance Equation [7].

Application of vector addition onto Figure 2.8 would yield Figure 2.9.

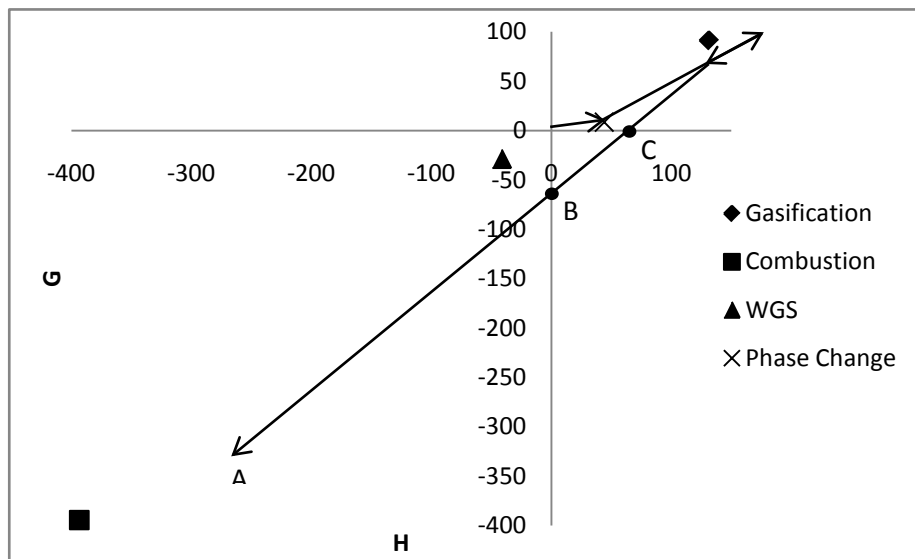

Figure 2.9: Vector addition of the four “gasification” reactions

The sequence of the addition in Figure 2.9 does not matter mathematically since the result of the vector addition will always be the same. The sequence of the addition could be a logical sequence for the reactors. For instance: water is turned to steam, so it is first in the sequence. Steam is reacted with coal in Reaction [1] coming second in the sequence. Reaction [3] uses the products from Reaction [1] placing it third in the sequence, after Reaction [1]. Coal is then

burned in oxygen, or air, to provide the work and heat needed for the reactions to proceed, so coming last in the sequence.

This sequence can then be used to develop a flowsheet as shown in Figure 2.10:

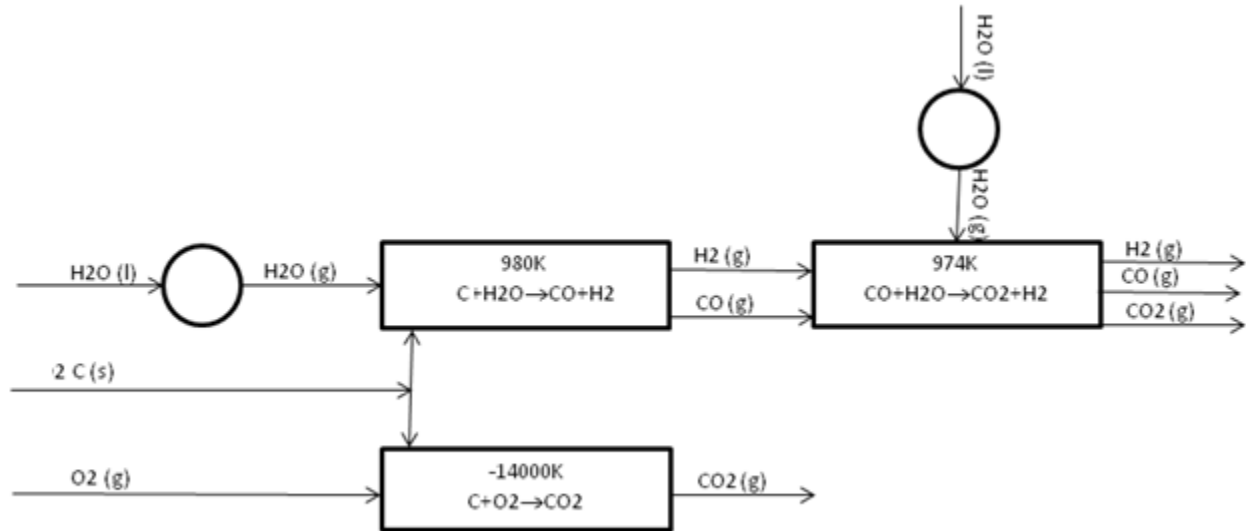

Figure 2.10: Flowsheet of a hypothetical process represented by the vector addition of Figure 2.9

Figure 2.9 and Figure 2.10 would represent a process that has each reaction taking place in its own reactor at its own Carnot temperature. This process has each reactor running reversibly as heat engines. As discussed earlier in this paper, this would not be a practical situation since the Carnot temperature for Reaction [2] is physically impossible to attain; that is why this process is termed hypothetical.

Whereas this hypothetical process will never be attainable in practice it does contain some important results.

Firstly, if the process of Figure 2.10 were run as a simple process (Figure 2.11), one where all of the reactions take place in a single reactor, it could be run reversibly if the Carnot temperature of -1260°C or -987K (which corresponds to point A on Figure 2.9, the final point of the vector addition) were attainable (which, of course, it is not).

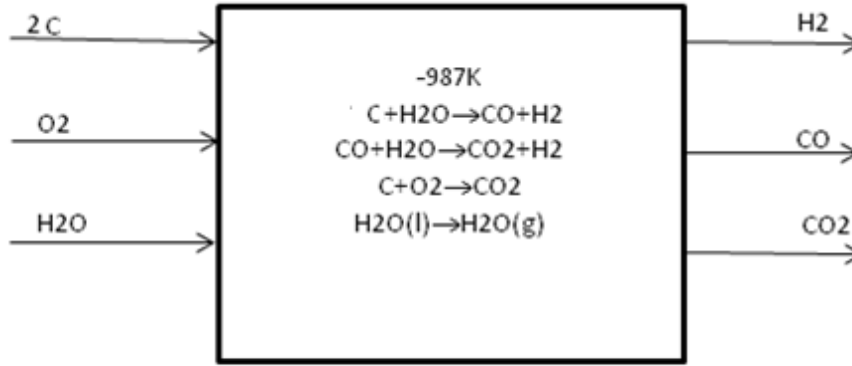

Figure 2.11: Gasification as a simple process at the operating point A of Figure 2.9

If the process were to be run as shown in Figure 2.10, the total work and heat recovered would be equal to the values read off the axes of Figure 2.9 at point A (adding together the enthalpies and Gibbs free energies where the Gasification and Combustion extents are 1 and the WGS extent is 1/3),

$$\Delta H = -268.74 \text{ kJ/mol and } \Delta G = -349.69 \text{ kJ/mol.}$$

Additionally, Figure 2.9 and Figure 2.10 also depict a process that is overall exothermic and work producing. This shows that too much coal is being burned in Reaction [2]. The vector for Reaction [2] can be shortened by burning less coal (by supplying less oxygen).

If the extent of Reaction [2] is decreased to a point where the overall process becomes endothermic, between points B and C on Figure 2.9, the reactions will be unable to proceed without additional heat. For gasification the only source of heat is Reaction [2]. So the extent of Reaction [2] will need to be increased again. It is also not desirable to burn too much coal, for an exothermic process between point A and B on Figure 2.9, since coal burning releases carbon dioxide and is harmful in terms of efficiency and environmental impact. Therefore the highest efficiency attainable for a gasification process is one where the process is overall adiabatic and in this case work producing, shown as Point B on Figure 2.9.

In the case of Figure 2.9, the process would be adiabatic and work producing. Since there is no heat leaving this process, a Carnot engine cannot be used to recover that work. In order for the process to be reversible, this work must be recovered through some other means. If this excess work is not recovered, it will be lost as process irreversibility since $\Delta G = \Delta H - T\Delta S$ where an adiabatic process would then be $\Delta G_{lost} = -T\Delta S$.

2.3.2.2 Phase two: temperature modification and reactor combination for an overall adiabatic process

It is now possible to consider a more realistic situation: namely, by having certain reactions take place in single units and by setting the reaction temperatures to values that are physically possible to obtain.

A quick review of literature gives a typical operating temperature for a gasifier as 1200°C¹⁴ and for a low temperature water-gas shift reactor to be 130°C^{15,16}.

Reactions [1] and [2] show that both reactions use coal as one of their feeds. It would be convenient to have both reactions occur in the same reactor, to share the same feed. This is an “auto-thermal” gasifier.

It would also be convenient to have both reactions share the same unit of coal, such that:

$$e_1 + e_2 = 1 \quad [8]$$

This unit, combining Reactions [1] and [2], will hence be referred to as the gasifier.

In order to attain the desired ratio of CO and H₂ (1:2), the reaction products of Reactions [1] and [2] could then feed into a separate reactor where Reaction [3] would take place. This unit will be called the shift reactor. As previously shown in Equation [7], the extent of Reaction [3] must be one-third the extent of Reaction [1].

The material balance for Reaction [4] can also be shown to be:

$$e_4 = e_1 + e_3$$

This can be written in terms of the extent of reaction 1 only:

$$e_4 = \frac{4}{3}e_1 \quad [9]$$

The gasifier will operate at 1200°C which means the ΔG of Reactions [1] and [2] will need to be calculated by Equation [6] and then drawn onto the GH-space. This creates Figure 2.12.

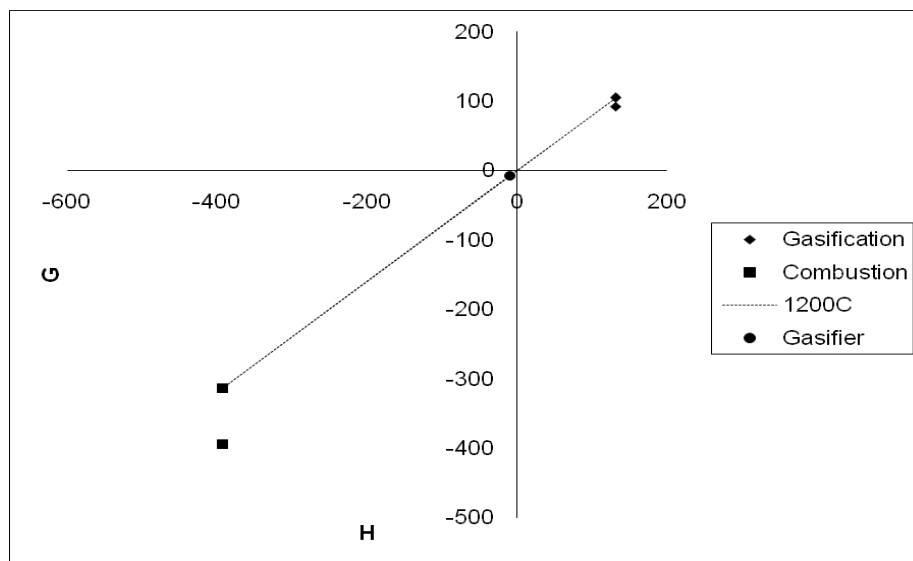

Figure 2.12: Combining gasification and combustion into a single unit at 1200°C, showing the effect of changing temperature on the Gibbs free energy

Figure 2.12 shows how the ΔG of the reactions in the gasifier changed when the reactions are not carried out at their Carnot temperature. It is clear that once the ΔG has been adjusted all the reactions are situated on the same straight line that passes through the origin. This line represents the 1200°C line. Any reaction or process that is on that line has a temperature of 1200°C. The overall gasifier will also be on that line if it is to operate as reversibly as possible at that temperature. The location of the gasifier on that line depends upon the extent of the gasification reaction, since Equations [7], [8] and [9] have defined the extents of all the reactions in terms of the extent of the Reaction [1].

Before that extent can be chosen, the GH-space needs to be generated for the shift reactor operating at 130°C.

Following the procedure used to generate Figure 2.12, Figure 2.13 is created.

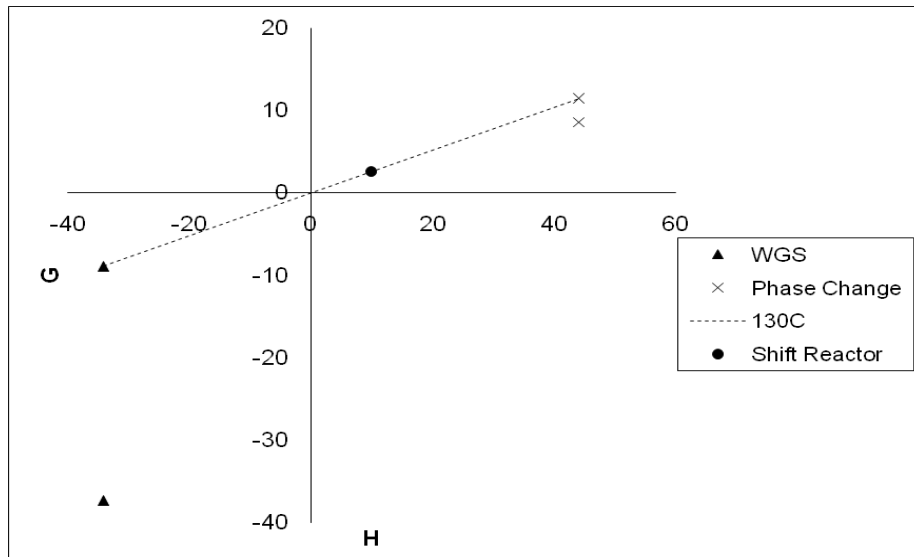

Figure 2.13: Combine WGS and phase change at 130°C, showing the effect of temperature change on the Gibbs free energy

Like Figure 2.12, Figure 2.13 shows the reactions that take place in the shift reactor have been adjusted to a temperature of 130°C. The final point for the shift reactor depends upon what extent of reaction is chosen for Reaction [1].

The material balances for all the reactions are summarized in Table 2.1.

Table 2.1: Summary of the material balances for all the process reactions

Reaction	Material balance
$C+H_2O \rightarrow CO+H_2$	e_1
$C+O_2 \rightarrow CO_2$	$1-e_1$
$CO+H_2O \rightarrow CO_2+H_2$	$1/3(e_1)$
$H_2O(l) \rightarrow H_2O(g)$	$4/3(e_1)$

The material balance for the process is in terms of the extent of Reaction [1] only. The extent of Reaction [1] should be chosen such that the overall process, gasifier and shift reactor *together*, will be adiabatic which represents the most efficient overall process as discussed above. This extent has a value of 0.67. Choosing this extent therefore sets the extent of the other reactions as:

$$e_1 = 0.67$$

$$e_2 = 0.33$$

$$e_3 = 0.22$$

$$e_4 = 0.89$$

By performing the vector addition with the points for the gasifier of Figure 2.12 and the shift reactor of Figure 2.13, Figure 2.14 is generated.

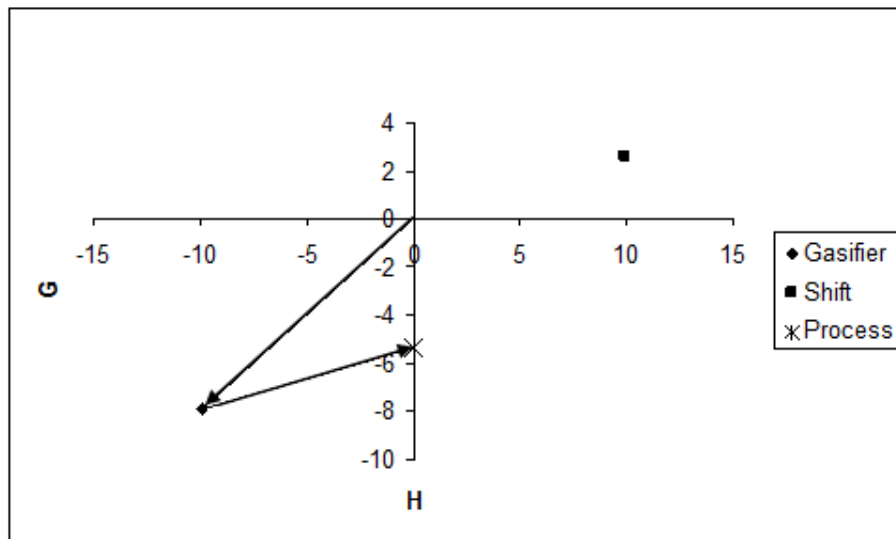

Figure 2.14: The overall process with the vector addition of the Gasifier and Shift units

The overall process has been set to be adiabatic and generates work as $\Delta G = -5.32$ kJ/mol. In order for the process to be run reversibly, that work needs to be recovered. One option (which is feasible since more gas moles leave the process than enter it) to recover that work is to operate the entire process at pressure and then depressurize in a turbine.

Equation [4] can be used to calculate what pressure would be needed to recover all the work. This pressure is calculated to be 4 atmospheres. This is not an unreasonable pressure. So all the information gathered from the GH-space can be used to generate a flowsheet for a gasification system. This is presented in Figure 2.15.

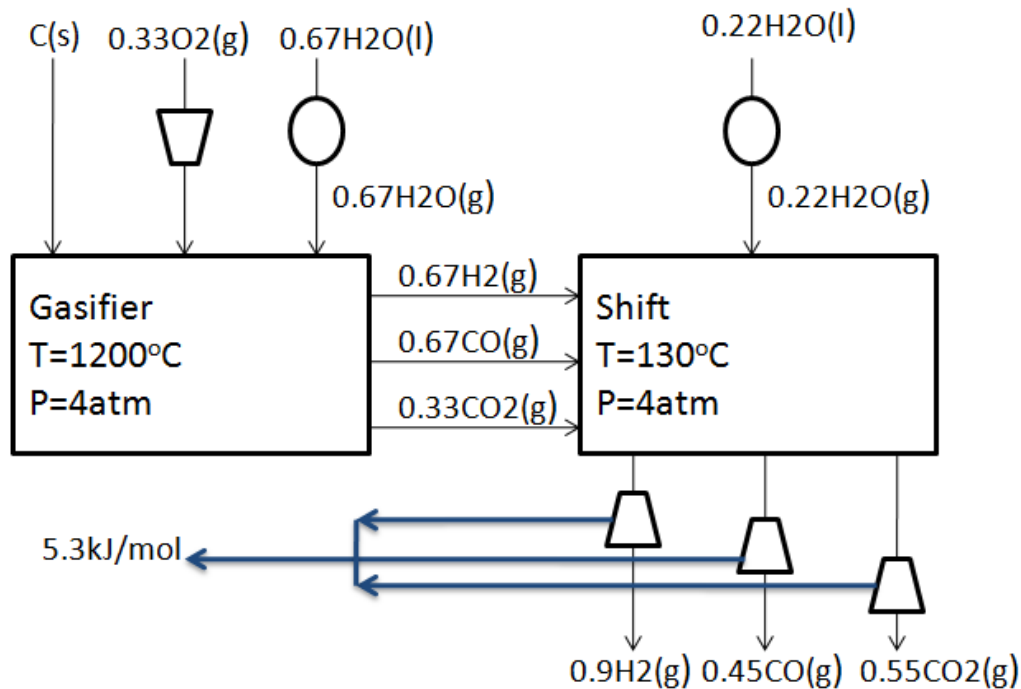

Figure 2.15: Reversible gasification process under ideal conditions including net work recovery

The important result of this process, Figure 2.15, is ΔG changes with constant enthalpy when the temperature is changed. *This means that, as long as the process remains overall adiabatic, the material balance for the process will not be affected by temperature.* Temperature will affect only the quantity of work that must be recovered from the process.

Figure 2.15 illustrates a very simple case. Improvements will be made by considering that Reaction [3] is actually an equilibrium reaction, consideration will be given to the mixing terms and changes to reaction temperature will be investigated.

2.3.2.3 Phase three: equilibrium of the water-gas shift reaction

Figure 2.15 showed that the gasifier and the shift reactor both use water as a feed. It should also be noted that the water-gas shift reaction is, in fact, an equilibrium reaction. This means that, when considering the equilibrium, more water is going to be needed in the shift reactor than that which is shown in Figure 2.15. It may be possible to introduce a water recycle to supply all, or some, of the water used by the gasifier.

By considering the equilibrium of Reaction [3] it is possible to calculate the water requirements as follows:

The equilibrium constant is given by:

$$K_3 = \frac{(CO_2)(H_2)}{(CO)(H_2O)} \quad [10]$$

Since the desired CO:H₂ ratio is 1:2:

$$K_3 = 2 \frac{CO_2}{H_2O}$$

Inserting the material balances then gives:

$$K_3 = 2 \frac{(e_2 + e_3)}{(e_1 + e_3)}$$

Rewriting this in terms of the extent of Reaction [1] only:

$$K_3 = \frac{3}{2} \frac{(1 - \frac{2}{3}e_1)}{e_1} \quad [11]$$

Thus by choosing the extent of Reaction [1], such that the overall process is adiabatic, the equilibrium for Reaction [3] can be determined at any particular temperature. From the material balances it can then be found how much water is being fed into the shift reactor. The result of that calculation is given by:

$$H_2O_{feed}^{shift} = \frac{5}{3}e_1$$

It is known, from the material balance, that the amount of water required by the gasifier is equal to the extent of Reaction [1], e_1 . This means that the amount of water leaving the shift reactor is greater than the amount of water needed by the gasifier. It is then possible to recycle the excess water of the shift reactor to the gasifier, removing the need for a feed of fresh water to the gasifier.

By applying the GH-space to the system once again, as detailed in Section 2.3.2 above, new extents of reaction can be selected for adiabatic operation and the operating pressure that will recover all the work can be calculated. This then gives rise to a new flow diagram presented as Figure 2.16.

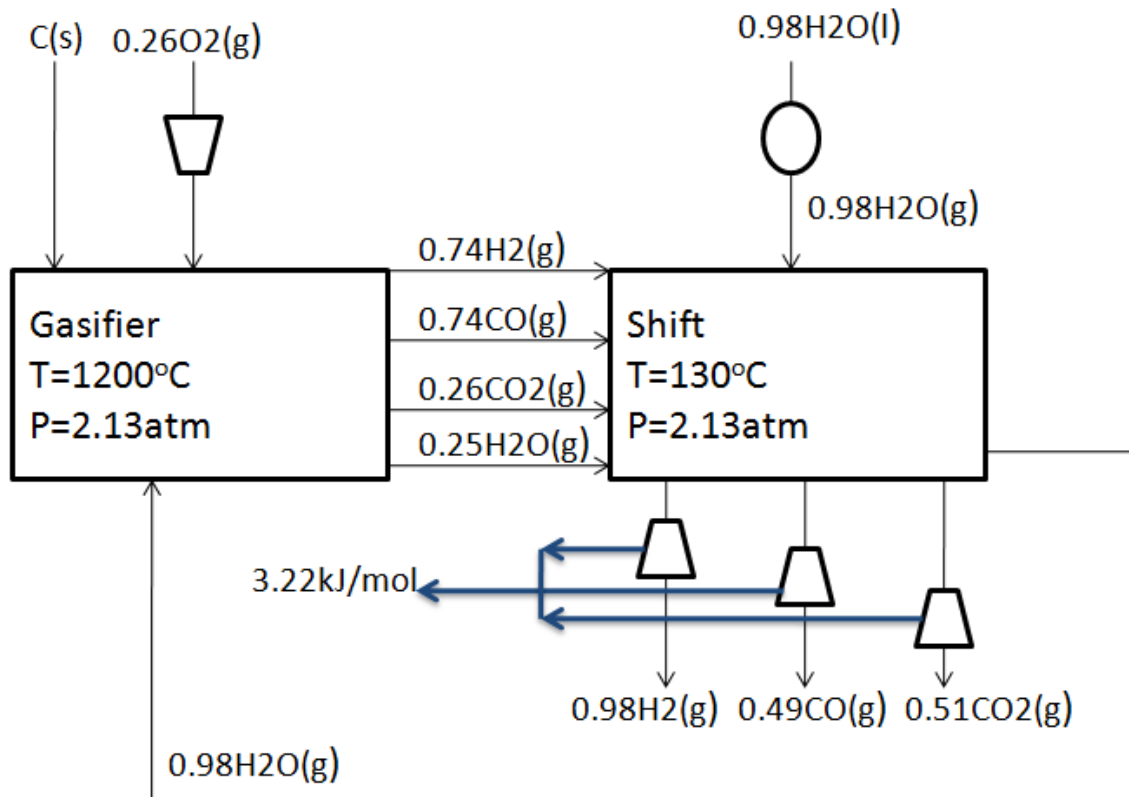

Figure 2.16: Gasification process, with water recycle from water-gas equilibrium and work recovery

The important result of this process, Figure 2.16, is that by considering the equilibrium of the water-gas shift reaction, a recycle stream has been introduced that provides the most efficient use of the water within the process.

2.3.2.4 Phase four: further modification of the operating temperatures and the mixing term

So far the gasification system that has been investigated has operated at the temperatures of 1200°C for the gasifier and 130°C for the shift reactor, which were considered to be typical reaction temperatures for industrial reactors.

It may be possible to change the two temperatures in such a manner as to decrease the amount of work that needs to be recovered from the process. This will be observed as a decrease in the process's operating pressure, it may even be possible for the process to operate at ambient pressure.

Consider Figure 2.17, a diagram that is identical, in purpose, to Figure 2.14:

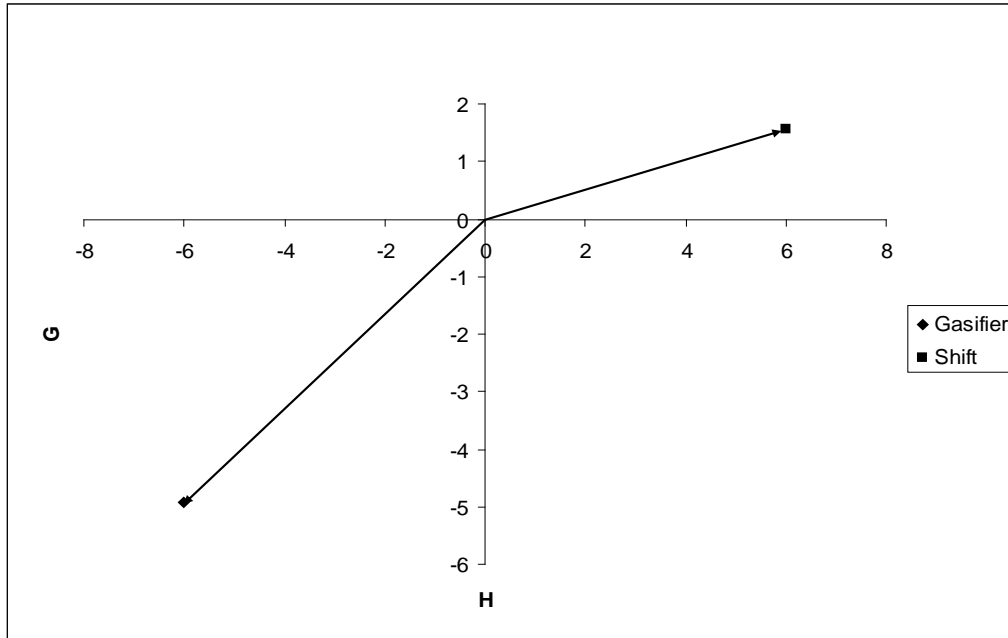

Figure 2.17: The overall process with the “gasifier” vector at 1200°C and “shift” vector at 130°C

In Figure 2.17 the gasifier and shift reactor are shown operating at their previous temperatures of 1200°C and 130°C. Now the temperatures should be chosen such that the addition of the two vectors together will be adiabatic, as shown in Figure 2.14, and be reversible, $\Delta G_{\text{process}} = 0$.

By applying Equation [6] to the two points in Figure 2.17, new values of ΔG can be calculated for the new operating temperatures, as detailed in Figure 2.12 and Figure 2.13.

Figure 2.17 shows that $\Delta H = 0$ and $\Delta G = 0$ only when the temperatures of the two reactors are the same. Therefore if the temperatures of the two reactors are the same the process can be run adiabatically and reversibly. However, in this case, the GH-space gives no information as to specifically which temperatures should be used. *The GH-space shows only that any temperatures can be used as long as they are the same.*

This is because the origin of the GH-space, $\Delta H = 0$ and $\Delta G = 0$, is the point where temperature is undefined. At this point the GH-space cannot give any information on what operating temperatures should be used. This, in turn, means that the temperatures for the reactors cannot be directly determined from the GH-space but must be inferred from other data or treated as a degree of freedom that can be modified to meet certain specifications.

By using the material balance, Equation [7] and Equation [8], and the chemical equilibrium constant, as derived in Section 2.3 above, it is possible to determine the temperature required for the shift reactor.

It is known from thermodynamics that:

$$\frac{d \ln K_3}{dT} = \frac{\Delta H_{rxn}^0}{RT^2} \quad [12]$$

Where:

- K_3 is the Equilibrium Constant for Reaction [3]
- R is the gas constant
- T is temperature
- ΔH^0_{rxn} is the enthalpy of reaction at standard conditions

The integration of Equation [12] is performed with the limits of temperature at the shift reactor temperature and at ambient temperature. The limits of the equilibrium constant will be at the Shift reactor temperature, which is given in Section 2.3, and the ambient temperature which is given by:

$$\ln K_3 = \frac{\Delta G^0_{rxn}}{RT_0} \quad [13]$$

Where:

- K_3 is the equilibrium constant for Reaction [3]
- R is the gas constant
- T_0 is the ambient temperature
- ΔG^0_{rxn} is the Gibbs energy of reaction at ambient conditions

Thus the temperature of the shift reactor can be calculated to be 600°C. Which is the temperature required to produce the equilibrium that provides an adequate extent of water-gas shift that will provide the 2:1 hydrogen:carbon monoxide ratio.

It has been assumed that the reactors have been producing separate pure components. Equation [5] can be applied to both the gasifier and the shift reactor, and the mixing terms can be calculated as vectors on the GH-space. These vectors can then be added to the other vectors on the GH-space for each of the units in the process.

Considering ideal mixing in the gasfier, Figure 2.18 can be drawn.

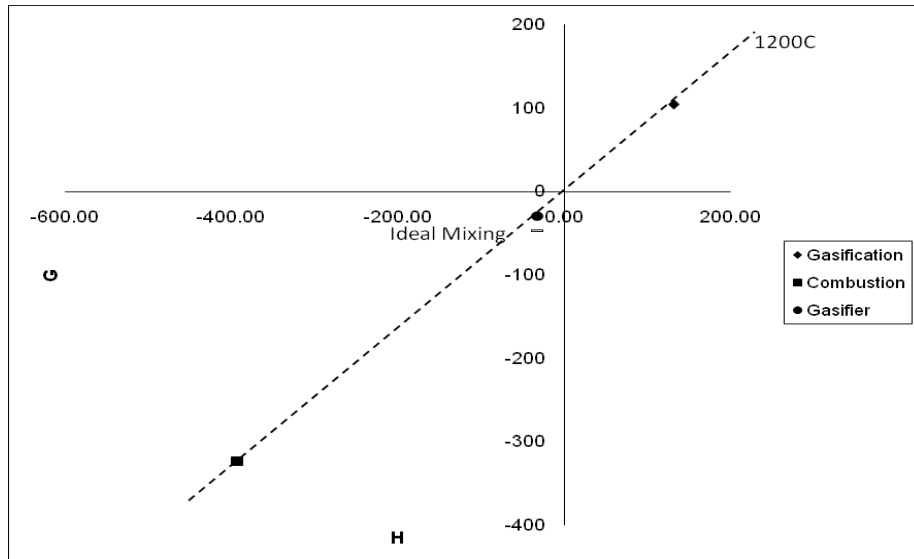

Figure 2.18: Gasifier, vector addition of Gasification reaction and Combustion reaction, at 1200°C with ideal mixing

Figure 2.18 shows the operating points at 1200°C as shown in Figure 2.12. In this case notice how the final point for the gasifier has moved down to the dash point. This move is due to the ideal mixing that has been considered for the gasifier.

A similar method can then be applied to the shift reactor, which gives rise to Figure 2.19.

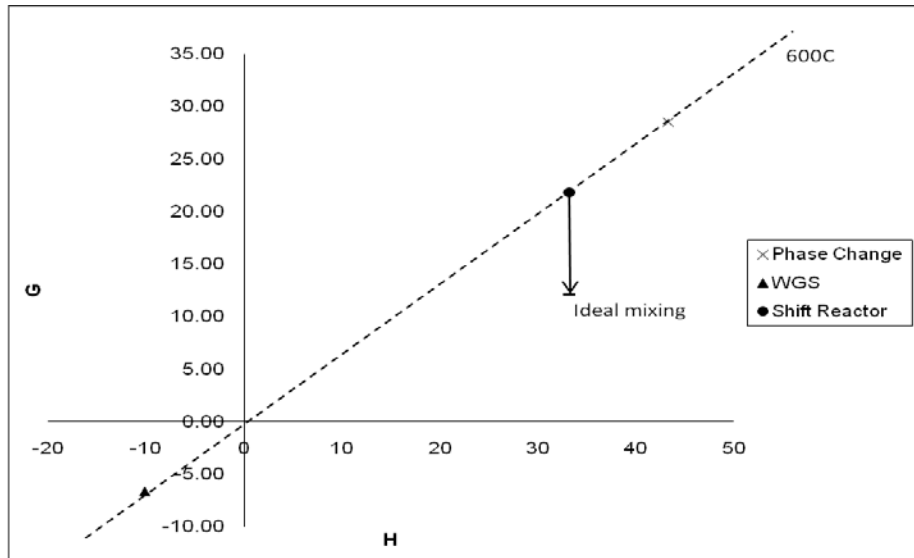

Figure 2.19: Shift reactor, vector addition of Phase Change reaction and WGS reaction, at 600°C with ideal mixing

Similarly to Figure 2.18, Figure 2.19 shows how the final point for the shift reactor has moved down due to ideal mixing.

The product from the shift reactor is a mixture of water, syngas and carbon dioxide. It would be useful to add in the separation of the water for recycle to the gasifier and to separate out the syngas product.

If one considers an ideal separation as the negative of an ideal mixing, this separation can be approximated by Figure 2.20:

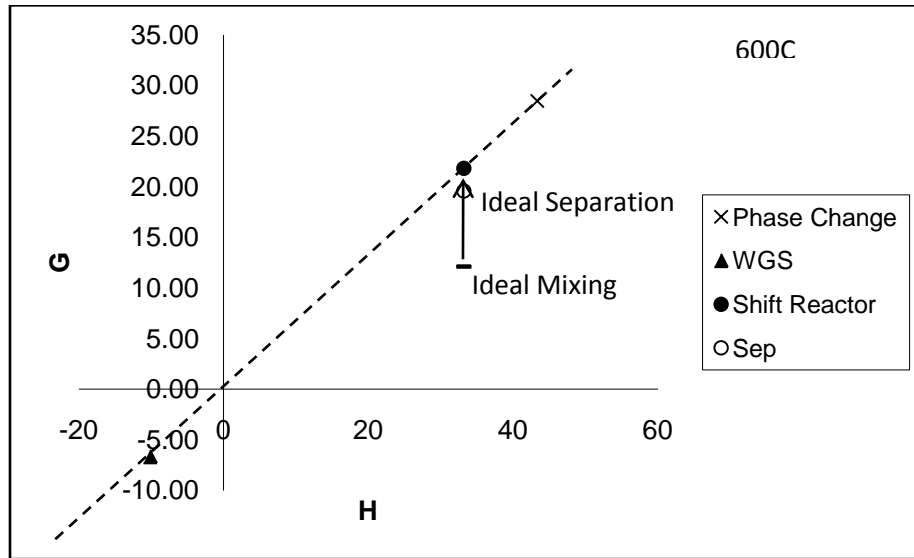

Figure 2.20: Shift reactor at 600°C with ideal mixing and ideal separation

An ideal separation is a separation where the minimum work required to achieve the separation (calculated by Equation [5]) is able to achieve this separation perfectly. In other words, an ideal separator separates the mixture into pure components with the minimum amount of work input.

Figure 2.20 shows how the shift reactor point moved up from the complete ideal mixing. Note that if the separation considered was complete, the ideal separation point would be exactly on top of the pure component point, which it is expected to be.

At this point the vectors corresponding to the final gasifier operating point (the point after mixing) and the shift reactor (after separation) can be added together to get the final operating point of the entire process. This is shown in Figure 2.21.

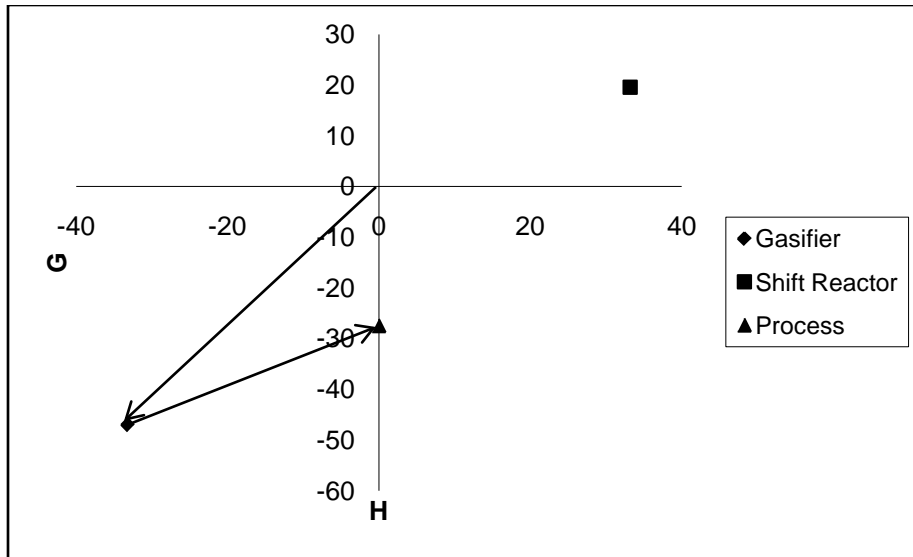

Figure 2.21: Vector addition of all reaction, mixing and separation vectors to give the overall process with WGS equilibrium, ideal mixing and ideal separation

The next step would be to use Equation [4] to determine the required pressure that would recover the excess work. Unfortunately a complication arises. The pressure required to recover all the work after the mixing and separation is considered, is in excess of 1000 atmospheres.

To attempt to correct this issue it is necessary to turn to another degree of freedom, which is to say the operating temperatures. The temperature of the shift reaction is set by the required equilibrium so the temperature of the gasifier becomes the remaining degree of freedom.

It was calculated that by increasing the temperature of the gasifier, the pressure required to recover the process work decreases; and by decreasing the gasifier temperature the pressure required to recover the work increases.

Clearly it will be necessary to increase the temperature of the gasifier. The question then becomes: by how much can the temperature be increased and how big an influence will this have on the work recovery in the process?

This question is perhaps best discussed on a graph, Figure 2.22.

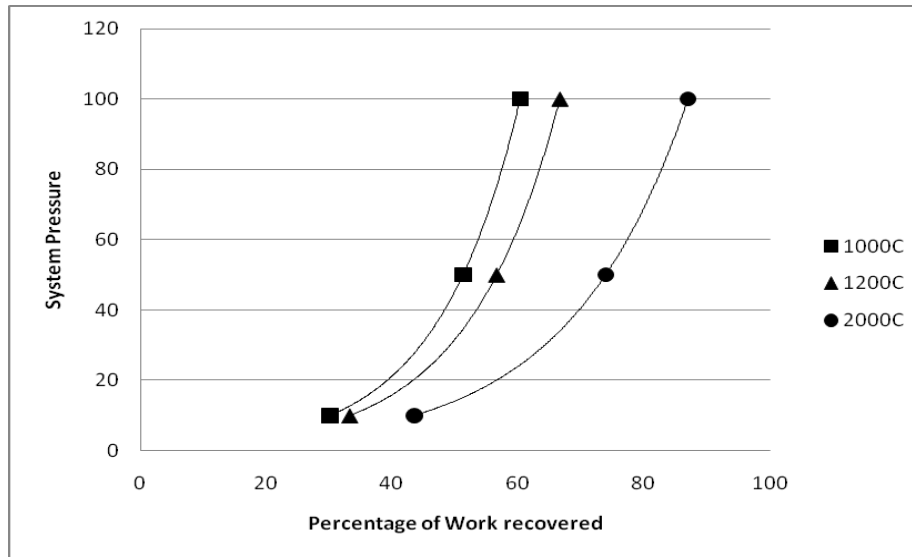

Figure 2.22: Percentage of work recovered with changes in pressure and gasifier temperature

From Figure 2.22 it is clear that decreasing the gasifier temperature decreases the amount of work that is recovered, as already stated. In terms of work recovery, there is no reason to go to a lower temperature. Lowering the temperature too much will also have the additional negative effect of preventing complete gasification. This, in turn, leads to other issues, which include the formation of methane and carbon dusting. However, simulations show that carbon dusting does not become an issue anywhere near the conditions presented in this paper. If dusting does occur, thermodynamics does not seem to be the cause.

The gasifier temperature used earlier in the flowsheet synthesis (1200°C), shows that 67% of the work available in the process will be recovered. The remaining 33% will be lost as irreversibilities.

A dramatic increase in temperature, such as to 2000°C shown in Figure 2.22, will increase the percentage of work recovered to 87% at 100 atmospheres. The major issue here is that this operating temperature is beyond the temperature of conventional gasification; it is moving into the realm of plasma chemistry.

Due to the shape of the curves, increasing system pressure will begin to have a diminishing return on the amount of available work recovered. How high a pressure to which the process can be taken, will have implications on materials of construction and plant safety.

It is clear, particularly in the case of conventional gasification, that there is always going to be a price to pay in terms work recovery and process reversibility.

Consider then choosing to operate the gasifier at the very high temperature of 2000°C, possibly as plasma, and operate the process at 75 atmospheres. With that choice made, a new flow sheet can be drawn, Figure 2.23.

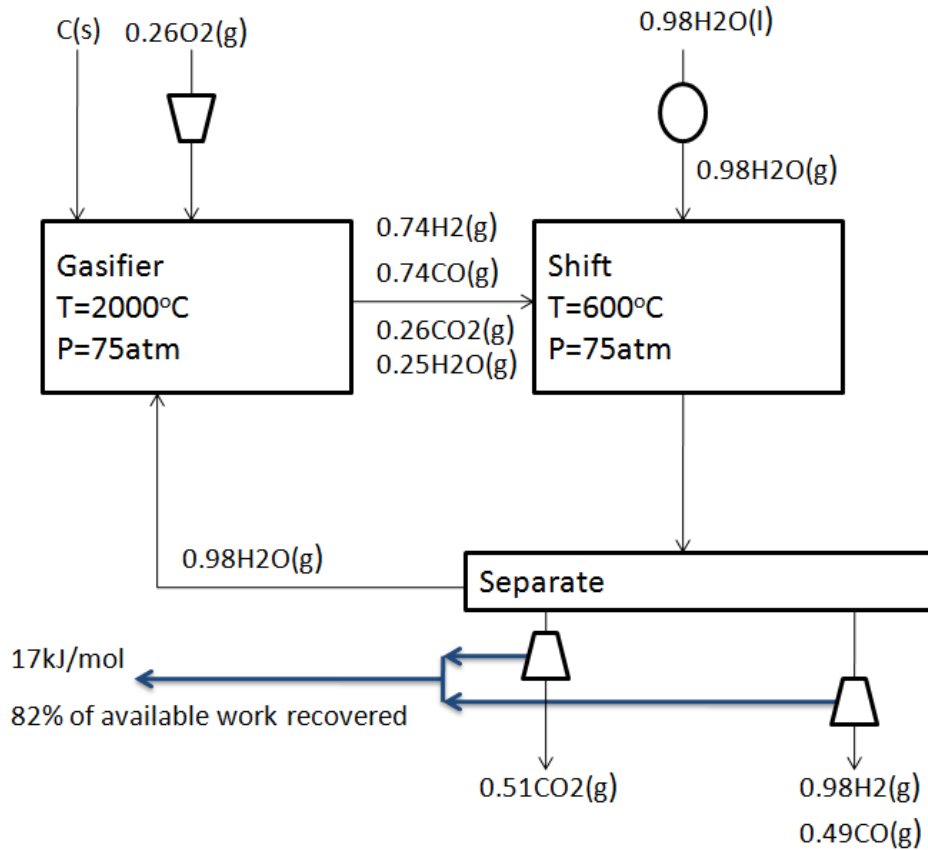

Figure 2.23: Gasification system with separation, mixing and modified gasifier temperature

Figure 2.23 is not a final flowsheet; it may not even be the best flowsheet. Such a flow sheet would depend on the chosen gasifier temperature and the chosen system pressure. What the best choices are depends essentially on how high one can go based on practical and safety considerations. However, Figure 2.23 is the most efficient flowsheet for a gasification process operating with the gasifier unit operating at 2000°C , the shift reactor at 600°C and the system at 75 atmospheres.

The flowsheet of Figure 2.23 is overall adiabatic, produces the minimum amount of carbon dioxide, recovers 82% of the available work (the excess ΔG) as electricity and produces synthesis gas at the desired product specification of 2:1.

2.4 Conclusion

In the case of gasification, a hypothetical process with four reactions taking place in four separate units and operating at their Carnot temperatures, was considered. This process, although impractical and impossible to operate, showed that the most efficient a gasification process could be is given by an overall adiabatic process.

This process was then improved by adding the reactions that both used carbon (coal) as their feedstock into one unit and the other reactions that used the products of the first as its feed into a separate unit. The temperatures of these units were then modified to more reasonable levels. This led to the development of the process depicted in Figure 2.15.

The process was then further improved by considering the equilibrium of the water-gas shift reaction, which allowed a water recycle to be added to the process, and for the preferred reaction temperature of the shift reactor to be calculated.

By adding the work of mixing into the flowsheet synthesis a separation system could be added to the flowsheet.

The effect of mixing and separation on the flowsheet was shown to be significant, requiring very high temperatures and system pressures to recover all of the available work. At this point the appearance of the final flowsheet will depend on the practical considerations that come from construction and process operability.

It is clear from this synthesis that in terms of coal gasification, there will always be a price to pay. It seems highly unlikely that a coal gasification process could ever be run completely reversibly. The synthesis does show how conditions could be chosen to get as close as possible, minimizing what losses are present, and making the best use of what is available.

Starting from the simplest of hypothetical processes and increasing the complexity, it has been shown that the GH-space can be used to develop increasingly detailed process flowsheets. These flowsheets are as efficient as they could be; they represent the “best case” scenario. Naturally the realities of the construction and operation of such a process might change things significantly but they still provide a valuable basis for the construction of new processes or for identifying the location of inefficiencies in existing processes.

Although this paper focuses on the application of the GH-space to gasification, the GH-space can be applied to any process system. Gasification is normally the first step in a much larger process. The other parts of such a process could also be synthesized on the GH-space. Processes of great complexity, consisting of many reactions, units and sections, can all be analyzed and synthesized on this single set of two-dimensional axes.

Perhaps the most important application of the GH-space is that it allows the *interactions* of all the process units to be investigated from the very beginning of the design (as opposed to the end, which is normally the case). At these early stages of design, the greatest changes and innovations can be made, before there has been too much investment of time and money. The GH-space

helps facilitate these innovations, which will aid greatly in making the next generation of processes as efficient and environmentally friendly as they can be.

Another valuable application of the GH-space is it allows flowsheets to be constructed from fundamental thermodynamic principles. It is entirely possible for experienced designers to formulate similar or even identical flowsheets as those constructed using the GH-space. However the simple, yet elegant, principles used by the GH-space allows flowsheets to be formulated by any designer, even one who has more limited experience.

References

1. Rosen, M. A. and Dincer, I. (2001) Exergy as the confluence of energy, environment and sustainable development. *Exergy, An International Journal*. **1** (1), 3-13
2. Kokossis, A.C. and Briones, V. (1999) Hypertargets: A Conceptual Programming approach for the optimisation of industrial heat exchanger networks-I. Grassroots design and network complexity. *Chemical Engineering Science*. **54** (4), 519-539
3. Kokossis, A.C. and Briones, V. (1999) Hypertargets: A Conceptual Programming approach for the optimisation of industrial heat exchanger networks-II. Retrofit Design. *Chemical Engineering Science*. **54** (4), 541-561
4. Kokossis, A.C. and Briones, V. (1999) Hypertargets: A Conceptual Programming approach for the optimisation of industrial heat exchanger networks-III. Industrial Applications. *Chemical Engineering Science*. **54** (5), 685-706
5. Floudas, C. A and Kokossis, A. C. (1990) Optimization of Complex Reactor Networks-I. Isothermal Operation. *Chemical Engineering Science*. **45**(3), 595-614
6. Floudas, C. A. and Kokossis, A. C. (1994) Optimization of Complex Reactor Networks-II. Non-Isothermal Operation. *Chemical Engineering Science*. **49** (7), 1037-1051
7. Floudas, C. A. and Anastasiadis, S.H. (1988) Synthesis of distillation sequences with several multicomponent feed and product streams. *Chemical Engineering Science*. **43**(9), 2407-2419
8. Mahalec, V. and Motard, R. L. (1977) Procedures for the Initial Design of Chemical Processing Systems. *Computers and Chemical Engineering*. **1**(1), 57-68
9. Westerberg, A.W. (2004) A Retrospective on Design and Process Synthesis. *Computers and Chemical Engineering*. **28**(4), 447-458
10. Sempuga, B.C., Hausberger, B., Patel, B., Hildebrandt, D., Glasser, D. (2010) Classification of Chemical Processes: A Graphical Approach to Process Synthesis to Improve Reactive Process Work Efficiency. *Ind. Eng. Chem. Res.* **49** (17), 8227-8237
11. Oaki, H. and Ishida, M. (1982) Study of Chemical Process Structures for Process Synthesis. *Journal of Chemical Engineering of Japan*. **15**(1), 51-56
12. Patel, B., Hildebrandt, D., Glasser, D., Hausberger, B. (2005) Thermodynamic analysis of processes.1. Implications of work integration. *Ind. Eng. Chem. Res.* **44** (10), 3529-3537
13. Patel, B., 2007, Fundamental Targets for the synthesis and evaluation of chemical processes. Thesis, (PhD), University of the Witwatersrand
14. van der Ploog, H.J., Chhoa, T., Zuideveld, P.L., 2004. The Shell Coal Gasification Process for the US Industry, *Gasification Technology Conference*, Washington DC, October

15. Bera, P., Malwadkar, S., Gayen, A., Satyanarayana, C.V.V., Rao, B.S, Hegde, M.S. (2004) Low Temperature Water Gas Shift Reaction on Combustion Synthesized Ce-Pt-O Catalyst. *Catalysis Letters*. **96** (3-4), 213-219
16. Park, S-J., Lee, D-W., Yu, C-Y., Lee, K-Y., Lee, K-H. (2008) Hydrogen Production from DME reforming-membrane reactor using stainless steel-supported Knudsen membranes with high permeability. *Journal of Membrane Science*. **318** (1-2), 123-128

3 A Graphical Approach to Process Synthesis and its application to Steam Reforming

Abstract

It is common practice in chemical engineering to design processes sequentially. The type of product desired determines the choice of the feed materials that are introduced into the reactor networks. These in turn lead into the separation networks. The flows of heat and work are the final part of the sequence to be considered, with the application of heat exchanger networks, and any deficiency or excess in these flows is usually compensated for with the use of utilities.

Although the ongoing research into reactor, separation and heat exchanger optimization is of indubitable value, an aspect that is often overlooked in conventional research is the question: How do changes to one of the elements in the sequence affect the others? Most process designers do not address such matters until the next optimization of the sequence begins. The result of this sequential approach to design is that processes may contain a few very efficient units, but may also have others that are highly inefficient.

In this paper we propose a graphical technique that incorporates the flows of heat and work into the design of the process at a very early stage. The technique can be used to prepare flow sheets that represent a synthesized version of the elements that make up the complete process, rendering each component highly efficient.

This new design tool uses the thermodynamic properties of enthalpy (representative of process heat requirements) and Gibbs free-energy (representative of process work requirements) to develop process flow sheets that operate as close to reversibly as possible, and can be used as a foundation for more detailed refinements to achieve the best possible result.

In a previous paper we described a case in which the graphical technique was applied to gasification. This article will detail the application of the technique to the production of syngas by the steam reforming of natural gas. We show that the steam reforming process can be operated with increased reversibility and can actually consume carbon dioxide, thus representing a process with a carbon efficiency of greater than 100%, if the way in which all the process units interact with one another is used to utmost advantage.

3.1 Introduction

With the increasing pressure on industries to maximize their productivity and minimize their impact on the environment, the efficient use of work and heat is becoming increasingly important. This raises the question of whether the processes entailed in industry are designed to function at an optimal level.

Traditionally, process design has been sequential: the feed materials enter reactors to form products, which then pass into some kind of separation system that removes impurities and unreacted feed. This type of design creates the very simplest form of flow sheet. At a later stage, attempts are made to improve the functioning of the reactor and separation systems. The sequential approach to process design has been the focus of a great deal of existing research, which has included reactor sequencing,^{1,2,3} heat exchanger network optimization,^{4,5,6} and distillation sequencing.^{7,8,9}

Although there is a great deal of merit in this research, such sequential methods of design can be problematic. For example, reactors are often the first units to be optimized, with the designers placing a strong emphasis on very high overall conversion, which usually requires that the reactors have substantial recycles. However, these recycles put a heavy strain on the separation systems, which will lead to complications when the process designers are working on raising their operational efficiency. Conversely, optimizing the separation systems before the reactor systems can lead to undue strain being placed on the performance of the latter. This leads to processes that may have a few very efficient sections but may be inefficient overall. Again, it is normally the case that the flows of heat and work within a process are considered only *after* these reactor or separation optimizations are completed and the process flow sheet has been finalized.^{10,11}

In this paper we propose an alternative method to sequential design. The concept on which we base this graphical technique rests on defining the enthalpy and Gibbs free energy for all unit processes, and representing them as vectors on a plot of enthalpy and Gibbs free energy, called the GH-space. Enthalpy depicts the flows of heat within a process, while Gibbs free energy portrays the flows of work. By manipulating the vectors in the plot, we can determine the overall mass, energy and work balances before any flow sheet exists. These vectors can be used to begin constructing a flow sheet that represents a process that is as thermodynamically as efficient as it can be *in its entirety*.

In this paper the GH-space is used as a synthesis tool that helps to construct the flow sheet. It can also be used as an analytic tool, for example when an existing flow sheet is checked for thermodynamic flaws. However, the latter is the subject of ongoing research, and falls outside the ambit of this paper.

In an article published previously, the graphical technique was applied to gasification processes, through which coal was used to produce synthesis gas (syngas), a gaseous mixture of hydrogen and carbon monoxide. It is a highly versatile feedstock that is extensively used in the production of many hydrocarbon products, including a range of alcohols and synthetic fuels. The ratio of

hydrogen and carbon monoxide in the syngas varies according to the use for which it is intended. The production of fuels, for instance, usually requires a ratio of 2:1 hydrogen: carbon monoxide.¹²

Although we continue to use the same technique in this paper, the subject in this case is the production of syngas via a steam reforming process, through which light hydrocarbons, such as methane and/or propane, are converted into a gaseous mixture of carbon monoxide, carbon dioxide and hydrogen.

There are three issues that arise in the context of syngas production:

- Typically, reformers emit some carbon dioxide, and release heat by generating high-temperature steam: the model we propose will suggest ways in which this energy can be harnessed without the need to generate steam.¹³
- A great deal of the existing research on steam reforming^{14,15,16} focuses on improving efficiency by examining the catalysts used. This approach focuses almost entirely on the reaction itself, and gives little consideration to the process as a whole.
- An important goal for the designer is improving the thermal efficiency of the process by the recovery of excess heat and work. To improve the thermal efficiency this excess work and heat is completely integrated with the rest of the process, making the best possible use of the energy available. High-temperature steam can be put to use, and therefore it is important to prevent the loss of such energy. If we can find ways to apply this work potential, we can not only use it in other processes but prevent the harm that wastage of heat and work can do to the environment. In the graphical model we are suggesting, recovery is shown by the use of minimizing exergy (the degree of departure from equilibrium with its environment in a system).¹⁷

The second section of this article provides an explanation of the graphical technique we have developed, and the way in which it can be used to depict the functioning of processes. As the reasoning is complex, we have illustrated the techniques step by step, to prepare the ground for the section on steam reforming that follows.

3.2 The graphical technique

3.2.1 A simple process

The definition of a simple process is one in which the feeds enter and products leave the reactor under ambient conditions.¹⁸ There is also one position in the process operating at temperature T that allows the addition of heat, as is shown in Figure 3.1. The only irreversibility in a simple process is caused by the temperature at which this heat is added.

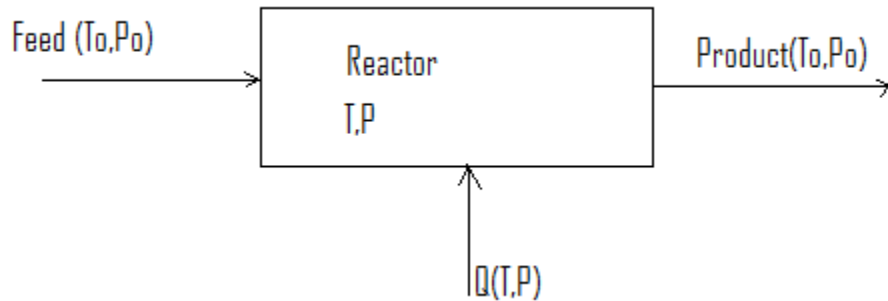

Figure 3.1: A simple process

$$\sum_i \nu_i M_{i,products} - \sum_i \nu_i M_{i,reactants} = 0 \quad [1]$$

Where:

- ν_i is the stoichiometric coefficient in the component i .
- The subscript i represents species i
- M is the mass of component i

If an energy balance is performed on the simple process, the change in enthalpy across the process can be calculated by:

$$\Delta \hat{H}_{process}^0 = Q = \left(\sum_i \nu_i \Delta \hat{H}_{f,i}^0 \right)_{products} - \left(\sum_i \nu_i \Delta \hat{H}_{f,i}^0 \right)_{reactants} \quad [2],$$

where:

- ν_i is the stoichiometric coefficient in the component i .
- The subscript f represents “of formation”
- The superscript 0 represents standard conditions.
- The subscript i represents species i .

This is to say that $\Delta H_{\text{process}}^0$, which is the net heat flow requirement of the process Q , is given by the difference between the enthalpies of formation of the products and the feeds, because both enter and leave at ambient conditions, which removes the enthalpy change attributable to heat capacity.

Similarly it is possible to calculate $\Delta G_{\text{process}}^0$ (which represents the minimum work requirement W) of the simple process by:

$$\hat{\Delta G}_{\text{process}}^0 = W = \left(\sum_i \nu_i \hat{\Delta G}_{f,i}^0 \right)_{\text{products}} - \left(\sum_i \nu_i \hat{\Delta G}_{f,i}^0 \right)_{\text{reactants}} \quad [3].$$

Where the process requires work and heat (positive values, from Equations [2] and [3]), these values ($\Delta H_{\text{process}}^0$ and $\Delta G_{\text{process}}^0$) represent the minimum of the amount of heat and work needed to be feasible. If the values were negative, the process would be feasible. The values calculated by Equations [2] and [3] would then represent the amount of heat and work that would need to be recovered for the process to be reversible. If the work potential of the heat, or the work itself, from such a process were not recovered, or utilized in some way, the work potential would be lost, and inefficiency would result.

3.2.2 Work addition

Now that the minimum heat and work requirements for a simple process have been defined, the next question is: How are these requirements (heat and work) to be met? Heat addition is self-explanatory: heat is transferred along temperature gradients and is well understood.

But how is work added?

The thermodynamic definition of ΔG , or the work, is given by equation [4]:

$$dG = -SdT + VdP + \sum_i \mu_i dN_i \quad [4],$$

where:

- μ_i is the chemical potential of species i .
- dN is the change in the number of moles of species i
- dT is the temperature change
- S is entropy
- V is volume
- dP is the change in pressure.

Equation [4] shows that there are three ways to add work to a process: using heat (TdS term); pressure (VdP term); and change in chemical potential, for example separation (μdN term)

3.2.2.1 Using heat to add work

In chemical processes, work requirements can be considerable. The bulk of the work is typically transferred via heat, by virtue of the temperature supplied. Processes reject or absorb heat as required by the energy balance, so it is advantageous to use this heat to supply or reject the work from the process simultaneously.

Heat has the potential to carry work by virtue of its temperature, and provides the principle that powers engines, as shown by the diagram of a heat engine in Figure 3.2 below.

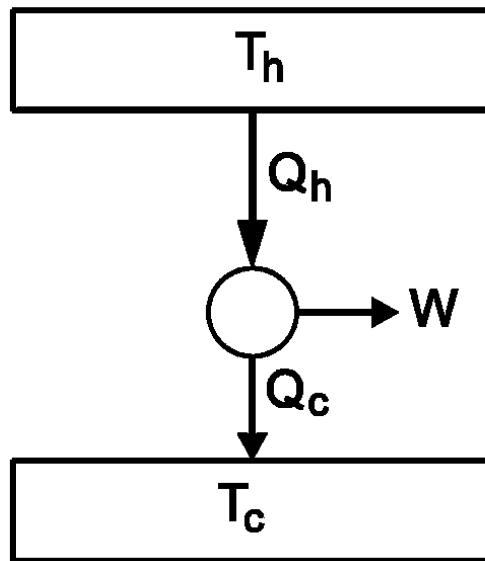

Figure 3.2: A heat engine depicting the relationship between heat, work and temperature

The amount of work conducted by the heat is given by the well-known Carnot equation for heat engines.

$$\hat{W}_c = \hat{Q} \left(1 - \frac{T_o}{T_h} \right) \quad [5],$$

where:

- W_c is the Carnot work
- ΔH is the heat requirements of the process ($Q=\Delta H$ for a process)
- T_o is the ambient temperature
- T is the temperature at which the heat is supplied.

In an ideal situation all the work would be carried out by the heat, alternatively expressed as $Q = \Delta H^0_{\text{process}}$ and $W_c = \Delta G^0_{\text{process}}$. This would mean the other two methods of work addition (pressure and chemical potential changes) would not be required. It would also imply that the work from Equation [5] would be exactly equal to the $\Delta G^0_{\text{process}}$ of the simple process calculated by Equation [3]. It can then be seen that this can happen at only one (Carnot) temperature, which is that *at which all the work required/rejected by the process will be conducted by the heat of the process*. This would be the ideal operating temperature for the simple process.

However, achieving this temperature often proves unworkable in practice. For example, when the $\Delta H^0_{\text{process}}$ and $\Delta G^0_{\text{process}}$ are very close together, the Carnot temperature will approach infinity; alternatively, when $\Delta G^0_{\text{process}}$ is greater than $\Delta H^0_{\text{process}}$ the Carnot temperature will be below absolute zero. This means that often heat must be added at more reasonable temperatures (resulting in a variation from the Carnot temperature), which results in deficiencies or excesses in the work requirements of the process. In such cases the process will have to be designed to accommodate these deficiencies/excesses.

This can be done by turning to the two additional methods for work addition/recovery mentioned above.

3.2.2.2 Using pressure to add work

Returning to Equation [4], we could consider work addition by compression. To solve the integral, we assume an isothermal compression of n moles of an ideal gas:

$$\Delta G_{\text{compression}} = nRT \ln\left(\frac{P}{P^0}\right) \quad [6],$$

where:

- n is the moles of gas
- R is the universal gas constant
- T is the compression temperature
- P and P^0 are the final and initial pressures respectively.

Equation [6] quantifies the amount of work that must be done on a gas stream to increase its pressure. It is important not to forget the definition of the simple process, in that the products must leave the system at ambient pressure. So it would be possible to apply Equation [6] to both the feed and product streams, bearing in mind that the product stream is being decompressed. This makes it possible to calculate the net work requirement for the simple process, which gives rise to:

$$\Delta G_{\text{compression, process}} = (n_{\text{in}} - n_{\text{out}})RT \ln\left(\frac{P}{P^0}\right) \quad [7],$$

where:

- n is the moles of gas entering (in) or leaving (out) the system
- R is the universal gas constant
- T is the compression temperature
- P and P^0 are the final and initial pressures respectively.

Equation [7] demonstrates an important principle: *It is possible to add work to a system using compression only when there are more gas moles entering the system than there are leaving it.* If the number of moles does not change, pressure does not add *any* work to the system; and if there are more moles leaving than entering, work can be *recovered* from the system.

The useful work that goes into changing the pressure is equal to the isothermal work (see Appendix B for proof), whereas the additional work that is used in an adiabatic compression causes an increase in temperature. Note that the assumption of an ideal gas can be relaxed if so desired.

3.2.2.3 Using separation to add work

The third method of adding work to a system is via separation. Once again, we assume that the system behaves ideally, although this assumption could be relaxed where desired. The ΔG for mixing will then be given by Equation [8]:

$$\Delta G_{\text{mix}} = RT \left(\sum_i x_i \ln x_i \right) \quad [8],$$

where:

- R is the universal gas constant
- T is the mixing temperature
- x is the mole fraction of component i .

It is worth noting that Equation [8] contains the appropriate sign to indicate the direction of work flow. In this case, a positive value denotes work addition, which in turn indicates a separation (while a negative sign would refer to a mixing process).

For these ideal systems, the ΔH for separation is zero.

3.2.2.4 Summary

To reiterate, we have defined a simple process in which both the feed and the products leave the reactor at ambient conditions. In this paper, for the purpose of illustrating the graphical technique without getting caught up in the details of more complex calculation, we present all the reaction units as simple processes. However, the assumption of a simple process can be relaxed at any time without affecting the technique; only the final result will change.

The method for calculating the heat and work requirements was defined, and we also showed that there are three ways (heat, pressure and separation) to add work to the process.

We also showed the useful work added via compression was done isothermally, and defined expressions for work and heat where the components behave ideally. In the interests of clarity (that is, to avoid adding complexity to the calculations), we have used these assumptions throughout this paper, although they can be set aside as needed. The overall principles will not change.

3.2.3 Graphical representation of the process work and heat requirements

Having outlined the method of calculating the quantities of heat and work, we can represent them graphically.

The heat and work flows of a process can be drawn onto a $\Delta H - \Delta G$ plot, hereafter referred to as the **GH-space**, and we can use the position of the point to describe the nature of the process. We demonstrated this technique in greater detail in our previous paper,¹⁹ in which we divided the plot into various sections and described the nature of the process that belonged to each section.

Other researchers²⁰ have carried out similar work that also employed a means of plotting ΔH and $T \Delta S$. This plot would probably provide a very sensitive measure of process efficiency and reversibility.

However, $T \Delta S$ is an abstract quantity that is not easily related to an actual, measurable quantity. The plot of ΔH against ΔG provides a simple link between the thermodynamics and the more easily-measured quantities of heat and work: ΔH is equal to the heat requirements of a process and ΔG is equal to the work requirements of a process. The next step is to consider a reaction that is carried out as a simple process, as defined above, to illustrate how it can be plotted in the GH-space.

3.2.3.1 Case 1: the combustion of methane in oxygen

The reaction for the combustion of methane in oxygen can be expressed as:

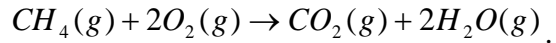

When Equations [2] and [3] are used on this reaction (along with the thermodynamic data provided in the Appendix), we find that the reaction is exothermic and work-producing (that is, ΔH and ΔG are both negative values). Having calculated $\Delta H^0_{\text{process}} = -802.35 \text{ kJ/mol}$ and $\Delta G^0_{\text{process}} = -800.71 \text{ kJ/mol}$, we can plot them on Figure 3.3.

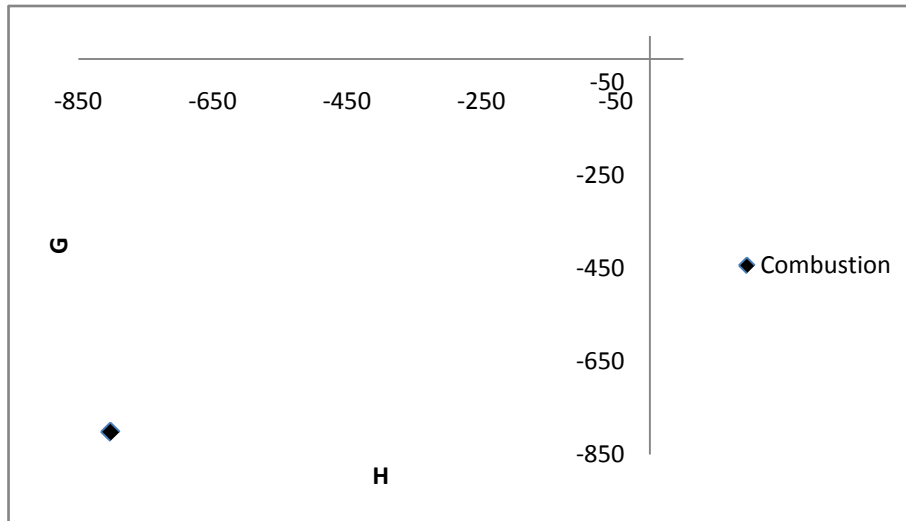
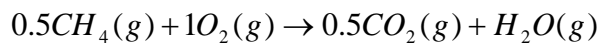

Figure 3.3: Reaction carried out as a simple process, represented as a point in the GH-space

The above Figure 3.3 shows the methane combustion reaction drawn onto the GH-space. As can be seen, the point sits in the third quadrant of the axes, as would be expected from an exothermic ($\Delta H^0_{\text{process}}$ is negative) and work-producing reaction ($\Delta G^0_{\text{process}}$ is negative).

Figure 3.3 also represents the reaction proceeding towards completion, which raises the question: What happens if one or both of the reactants is limited?

If the quantity of both reactants was decreased by 50%, the reaction (or process) equation would become:



Equations [2] and [3] could then be used again and the ΔH and ΔG recalculated. The alteration in values can be seen drawn onto Figure 3.4.

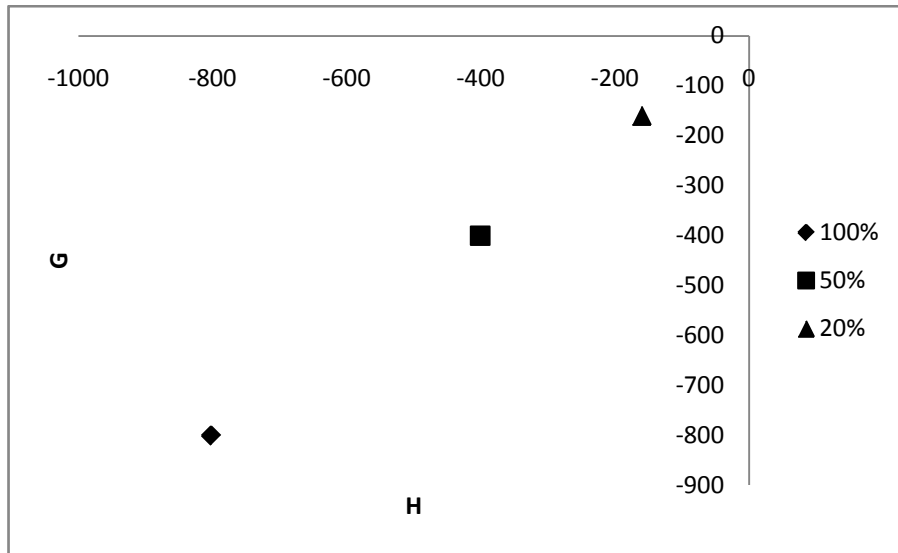

Figure 3.4: The effect of extent of reaction on the GH-space

The above Figure 3.4 shows the values of ΔH and ΔG calculated for differing quantities (100%, 50% and 20%) of reactants. This is analogous to the extent of the reaction, or how far the reaction has gone towards completion. It is also clear that not allowing a reaction to proceed to completion decreases the heat and work calculated from Equations [2] and [3], and that it does so in a linear fashion on the GH-space.

The combustion reaction could thus be represented as a line from the origin to its highest extent, which would represent all the possible extents of reaction. This means that *all reactions can be represented as lines* on the GH-space. Note that it is possible to have an extent of more than 100% by adding greater amounts of feed rather than less. This is illustrated in Figure 3.5.

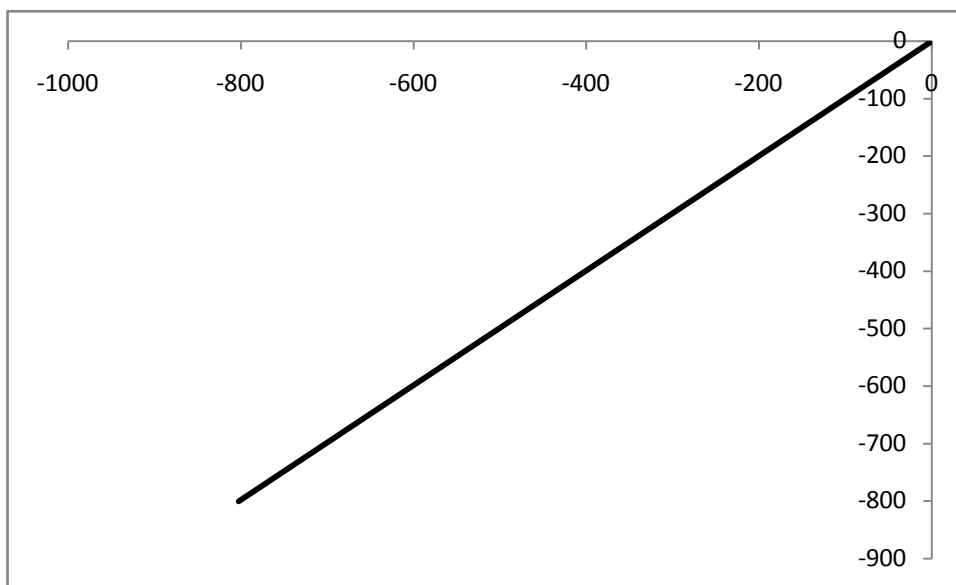

Figure 3.5: The set of all combustion extents with $0 \leq e \leq 1$ as a simple process where extent is defined for 1 mole of methane

The line drawn in Figure 3.5 represents the combustion reaction occurring at a particular temperature. When ΔH and ΔG are calculated from Equations [2] and [3] the temperature of the reaction line is the Carnot temperature as calculated by Equation [5], where temperature is related to the slope of the process line.

Using Equation [5], the Carnot temperature can be calculated to be 14500K. This is an example of a temperature that is unworkable. Clearly, therefore, a modification that allows for more workable temperatures has to be made to assist the calculation of the reaction lines.

Bearing in mind that as long as $C_{p,products} \approx C_{p,reactants}$, ΔH is not strongly affected by temperature, we can calculate ΔG for the reaction, at any temperature, from Equation [5], recalling that $W = \Delta G$. In this way, altering the temperature of a reaction will change the slope of the reaction line on the $\Delta H - \Delta G$ plot at constant enthalpy, as shown in Figure 3.6.

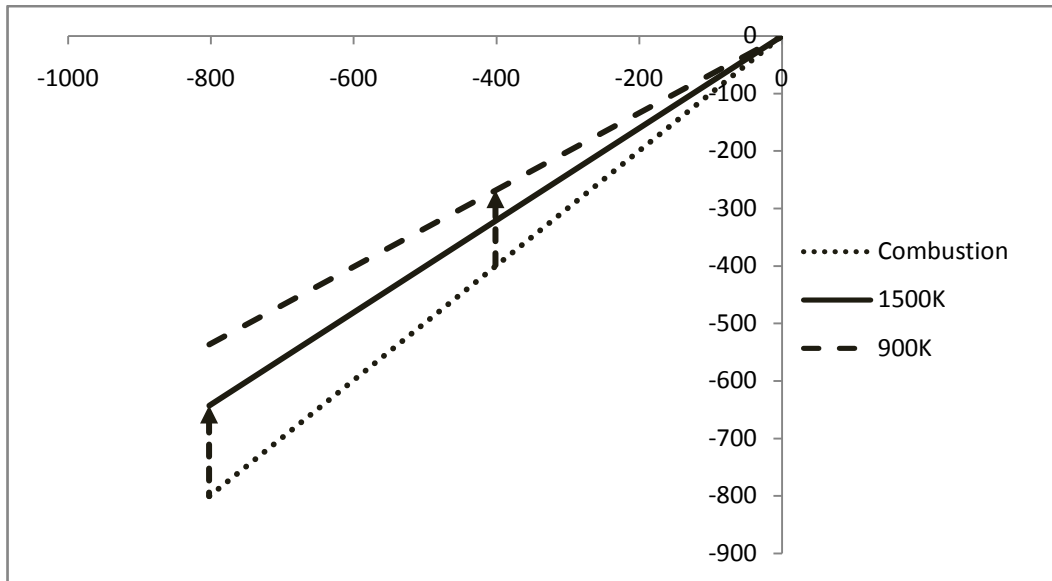

Figure 3.6: Effect of temperature on a simple process in the GH-space: combustion

Figure 3.6 shows the combustion reaction, at its Carnot temperature (approximately 150000K), as the dotted line; the solid line the combustion reaction at 1500K; and the dashed line combustion at 900K. At constant enthalpy the reaction line has shifted upwards along the dashed arrows as a result of the new ΔG calculated at 1500K and 900K, using Equation [5].

What the graphic in Figure 3.6 implies is that running an exothermic reaction at a lower temperature decreases the amount of work that can be recovered from the reaction: conversely, running it at a higher temperature increases it. In the case of endothermic processes, using a higher temperature increases the minimum work input required, while a lower decreases the work requirement.

3.2.3.2 Case 2: combusting methane to form carbon dioxide and water vapor

When methane forms water vapor and carbon dioxide through combustion, the heat and work from combustion is then used to produce additional steam.

The flow sheet of this hypothetical process might look like Figure 3.7.

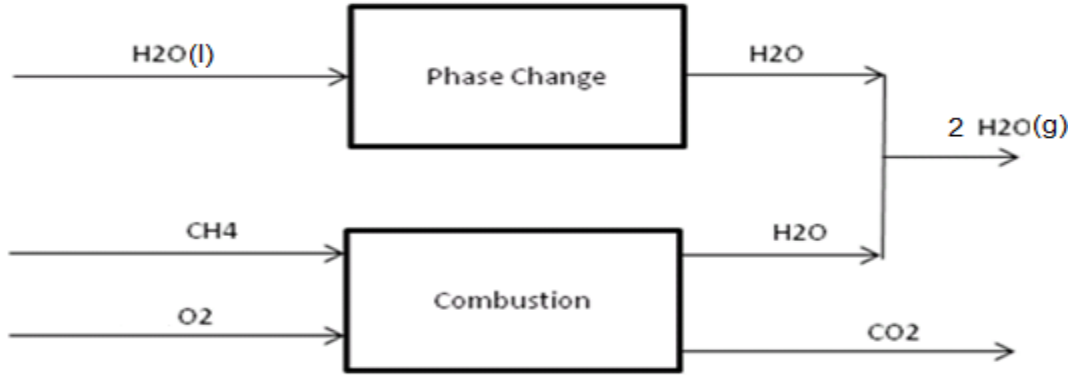

Figure 3.7: A hypothetical complex process consisting of a methane combusting process and then a steam producing process.

The $\Delta H^0_{\text{process}}$ and $\Delta G^0_{\text{process}}$ for the overall complex process shown in Figure 3.7 can be calculated in 2 ways. The first of these is to use Equations [2] and [3] (or Equations [2] and [5], if non-Carnot temperatures are desired) on the “combust” and “phase change” boxes independently, and add their results.

The second alternative would be to apply the equations to the process as a whole, using the *overall* feeds and products. In other words:

$$\Delta H_{\text{overall process}} = \Delta H_{\text{combustion, process}} + \Delta H_{\text{phase, process}}$$

$$\Delta G_{\text{overall process}} = \Delta G_{\text{combustion, process}} + \Delta G_{\text{phase, process}}$$

The heat from the combustion could be used to supply the heat for the phase change. It would also carry work with it by virtue of its temperature. The integration of the heat streams can be drawn onto the hypothetical flow sheet shown in Figure 3.8.

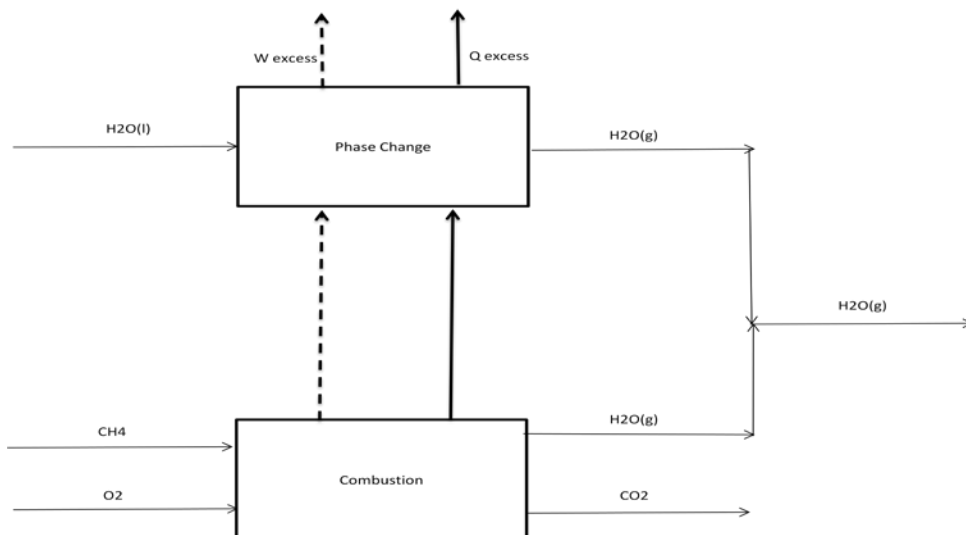

Figure 3.8: Mass, heat and work flow for the hypothetical complex process. Mass as solid lines, heat as bold lines and work as dashed lines.

The graphic in Figure 3.8 shows how the heat from the combustion is used to boil the water. The quantity of heat supplied by combustion is far greater than the amount required by the phase change, so it can be used to carry work (represented by the dashed line). Excess heat could also be represented as an excess work flow. Either way this excess must be rejected. In general practice, such excesses are simply lost to the environment.

The complex process shown in Figure 3.8 could also be drawn as an equivalent simple process, as in Figure 3.9 below.

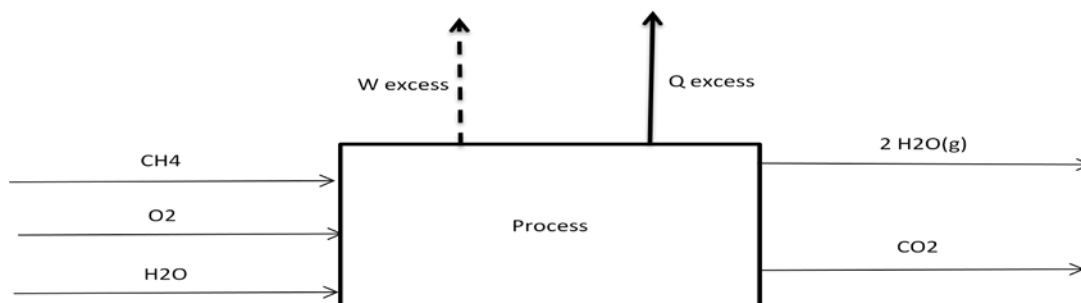

Figure 3.9: The complex combustion process drawn as a simple process

In terms of their overall $\Delta H^0_{\text{process}}$ and $\Delta G^0_{\text{process}}$, Figure 3.7 and Figure 3.9 are *exactly* equal. The difference between them rests on the fact that the complex process has two separate units. The advantage of this process is that heat and work can be added or removed at two different temperatures, which increases the number of degrees of freedom in the system. This in turn provides greater opportunity to improve the reversibility of the process, which is not possible in a simple process.

It is clear that the overall ΔH and ΔG for a process is the sum of its individual units. This is not by any means a new result: this principle is already well applied in process energy and work balances. However, it does show that reactions have length (which is defined by the extent of the

reaction) and direction (defined by the temperature); and that they can be added together. *This means that reactions are not merely lines on the GH-space, they are vectors.*

Having established that the heat and work for the overall process is the sum of the heat and work of the units in the process, we can state that not only are reactions vectors on the $\Delta H - \Delta G$, but so are the other unit processes of compression and separation. This is to say *that any unit process for which ΔH and ΔG can be defined can be represented as a vector on the GH-space.*

3.2.3.3 The next step

In this paper, we consider three unit processes: those corresponding to a reactor, a compressor/turbine and a separator. Since the compressors are considered as isothermal and the separators ideal, they have no ΔH , and are thus shown as vertical lines on the GH-space. If we were to use adiabatic compressors instead, the compression vector would no longer be vertical, but would have a horizontal component equal to the adiabatic work. This would appear to be similar to that of a reaction vector in that the compressor vector would now have a ΔG and a ΔH value.

3.3 Application to steam reforming

3.3.1 Defining the system

Having explained the primary idea behind the graphical technique, we can consider how the technique is applied in designing process flow sheets, taking as our example of methane steam reforming to produce syngas. The latter is used to make many products, such as hydrogen, syngas, methanol, ammonia and waxes. Many of these processes have a reputation for producing and releasing vast quantities of carbon dioxide. By using the GH-space synthesis tool we can investigate whether (and if so, how) this carbon dioxide production can be avoided; or whether it is simply a thermodynamic limitation of the system.

The **steam reforming reaction process** is given by:

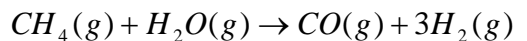

Equations [2] and [3] can then be applied to the reforming reaction process, and the heat and work requirements calculated as:

$$\begin{array}{ll} \Delta H_{\text{reforming}} & 206.12 \text{ kJ/mol} \\ \Delta G_{\text{reforming}} & 142.16 \text{ kJ/mol.} \end{array}$$

The above are the heat (206 kJ/mol) and work addition (142 kJ/mol) requirements of a reforming reaction, which also needs gas phase water (steam) as a feed. Because liquid water is the phase

that is most readily available, the steam has to be generated. This can be represented as a **phase change reaction process** (phase):

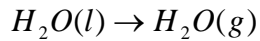

Applying Equations [2] and [3]:

$$\Delta H_{\text{Phase}} \quad 44.01 \quad \text{kJ/mol}$$

$$\Delta G_{\text{Phase}} \quad 8.56 \quad \text{kJ/mol,}$$

we find, unsurprisingly, that the phase reaction also requires an input of heat and work.

The reforming reaction also produces hydrogen and carbon monoxide in a 3:1 ratio. In certain cases, for instance in the production of ammonia or as a first step in high-purity hydrogen production, this may be desirable. However, a ratio of 2:1, which is better suited to downstream processes such as Fischer-Tropsch synthesis and methanol production, is more commonly used. Changes in the ratio are made possible by the **water-gas shift reaction process** (WGS):

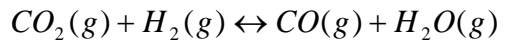

Again, applying Equations [2] and [3]:

$$\Delta H_{\text{WGS}} \quad 41.19 \quad \text{kJ/mol}$$

$$\Delta G_{\text{WGS}} \quad 28.59 \quad \text{kJ/mol.}$$

The WGS is an equilibrium reaction process. As written, it requires 41 kJ/mol of heat and 29 kJ/mol of work addition.

There are three reactions/processes that require the addition of heat and work. Neither the steam reforming nor the WGS reactions can occur unless the energy requirements are met. These can be supplied through a fourth reaction, combustion:

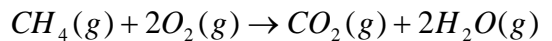

As already shown:

$$\Delta H_{\text{combustion}} \quad -802.35 \quad \text{kJ/mol}$$

$$\Delta G_{\text{combustion}} \quad -800.71 \quad \text{kJ/mol.}$$

The **combustion reaction process** is heat- and work-producing, and thus can provide all the heat and work required by the other reaction processes.

Since we have calculated the enthalpy and Gibbs free-energy of all the reactions, we can draw them on the GH-space, as has been done in Figure 3.10 below. It is important to note that Figure 3.10 is not drawn to scale, because in practice the reaction vectors (namely those for the WGS, reforming and phase) are nearly superimposed, unlike that for the combustion reaction, making it difficult to read the plot clearly.

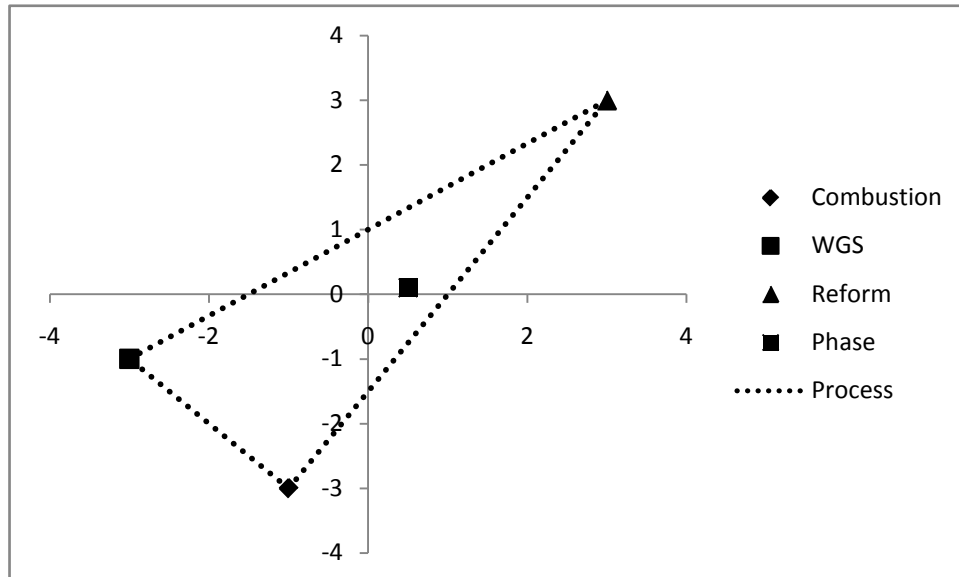

Figure 3.10: Steam reforming reactions plotted with exaggerated vector angles showing the area of all possible mass, energy and work balances and thus all possible process operating points.

The above shows the four reactions for steam reforming drawn onto the GH-space (not to scale). The dotted line joining the 3 outer reactions depicts the perimeter of an area on the GH-space. The points within this triangular region stand for a portion of the possible mass, energy and work balances that can exist, and represent some of the possible operating points for any steam reforming process. It does not indicate which operating points are best to use, or which processes meet the most desirable specifications for steam reforming.

A quick look at the ΔH and ΔG of the 4 reactions shows us that the combustion reaction provides a great deal *more* heat and work than is actually needed by the other 3 reactions put together. As it would be wasteful to provide too much heat and work, we need to control the extent of the combustion reaction so as to provide sufficient heat and work and no more. This can be done by feeding just enough oxygen for the combustion to take place.

There are three constraints on the design of the four reaction process.

1. Because the syngas product desired will have a hydrogen:carbon monoxide ratio of 2:1, the WGS reaction will have to be adjusted to meet this specification.
2. The extent of the phase reaction has to be designed to provide just enough steam for the reforming reaction. It is also worth noting that the steam produced by combustion can be used for reforming, allowing the phase reaction to make up the deficit (if there is one) in the supply of steam.
3. There should be sufficient combustion to provide the correct amount of heat and work (either $\Delta H_{\text{overall process}}$ or $\Delta G_{\text{overall process}}$ should equal zero). This can be achieved through the individual extents of reaction.

3.3.2 The material balance and the $\Delta H - \Delta G$ plot

We have identified the four reactions that are being considered in the design of the reforming flow sheet as reforming, WGS, phase change and combustion, and defined the design constraints.

With this information we can perform the material balance on the system:

$$\begin{aligned}
 N_{CH_4} &= N_{CH_4}^o - e_{\text{reform}} - e_{\text{combust}} \\
 N_{H_2} &= N_{H_2}^o + 3e_{\text{reform}} - e_{\text{WGS}} \\
 N_{CO} &= N_{CO}^o + e_{\text{reform}} + e_{\text{WGS}} \\
 N_{H_2O,l} &= N_{H_2O,l}^o - e_{\text{reform}} + e_{\text{WGS}} + 2e_{\text{combust}} \\
 N_{O_2} &= N_{O_2}^o - 2e_{\text{combust}} \\
 N_{CO_2} &= N_{CO_2}^o + e_{\text{combust}} - e_{\text{WGS}} \quad ,
 \end{aligned}$$

where:

- N_i^o is the initial feed of component i
- N_i is the remaining component i after reactions have taken place
- e is the extent of reaction.

At this stage, it is useful to set an additional design constraint. There are four unknowns, 3 constraints are needed. Both the reforming and combustion reactions use methane as their feedstock, so we could take the new design constraint to be that 1 mole of methane *intotal* is fed into the process (although in practice any amount of methane feed could be chosen: it simply becomes a question of scaling). This approach is equivalent to setting the process feed as opposed to the production rate. This means that the reforming and combustion reactions must now share the same 1 mole of methane. From the methane balance above, assuming the methane reacts to completion with none left unreacted:

$$0 = 1 - e_{reform} - e_{combust}$$

$$e_{reform} + e_{combust} = 1$$

From the hydrogen and carbon monoxide material balances above, since no hydrogen or carbon monoxide is initially fed to the process, we can calculate:

$$N_{H_2} = 0 + 3e_{reform} - e_{WGS}$$

$$N_{CO} = 0 + e_{reform} + e_{WGS}$$

At this point we must apply Constraint 2 to the material balance in order to obtain the desired H₂: CO ratio. This constraint can be written as:

$$N_{H_2} = 2N_{CO}$$

thus substituting the material balance:

$$(3e_{reform} - e_{WGS}) = 2(e_{reform} + e_{WGS})$$

$$e_{WGS} = \frac{1}{3}e_{reform}$$

What is most significant in the material balance given above is that for a 2:1 ratio of hydrogen to carbon monoxide *the extent of the WGS reaction must always be 1/3 of the extent of the reforming reaction.*

Constraint 2 can then be applied to the water material balance. Assume that water will always enter or leave the process in liquid phase only and that the two phases of water are different species. The amount of water initially fed to the process (or the amount of water excess water that must be removed from the process afterwards) is equal to the extent of the phase change reaction. Either the initial or final moles of water must be represented as 0. For example, if we consider the final moles of water to be 0, we would be indicating that the process consumes water rather than producing it. From the water material balance, we can derive:

$$0 = e_{phase} - e_{reform} + 2e_{combust} + e_{WGS}$$

$$e_{phase} = e_{reform} - 2e_{combust} - e_{WGS}$$

In other words, the amount of additional steam that will need to be condensed or recycled is given by the extent of the reforming reaction (which uses steam as a feed) less the extents of the combustion and WGS reactions, which produce steam (that can be supplied to the reforming reaction). If it turns out that the extent of the phase change reaction is negative, we can infer that the process is actually producing excess water and the phase change reaction needs to proceed in the opposite direction.

An alternative design could take the opposite case and set the initial moles of water to 0, thus assuming liquid water production (this assumption sets the phase change reaction in the opposite direction), this will make the extent of the phase change reaction positive if the process produces water (the assumption of water production was “correct”) and negative if it consumes it (the assumption of water production was “incorrect”). In either case the extent of the phase change will require a simple change of sign, the “correctness” of the assumption of water consumption or water production will be resolved mathematically.

Finally, we can consider the oxygen balance. If just enough oxygen is supplied to the combustion there will be no excess oxygen remaining. Thus, from the oxygen balance:

$$N_{O_2}^o = 2e_{combust}$$

It is possible for all the above material balances to be written in terms of only one of the reaction extents by substitution. In this paper all the extents have been written in terms of the extent of the reforming reaction. This allows us to choose the extent for the reforming reaction. All the other reaction extents will then have values determined by the material balance, which yields a syngas product of the desired 2:1 specification.

The material balances of all the reactions participating in the reforming unit process are given by the following formulations (the extent of the reforming reaction itself is a degree of freedom):

$$e_{combust} = 1 - e_{reform}$$

$$e_{WGS} = \frac{1}{3}e_{reform}$$

$$e_{phase} = \frac{8}{3}e_{reform} - 2$$

At this point it is possible to select any extent for the reforming reaction. Having done so, we can determine the material balance for the entire process and calculate the ΔH and ΔG for the process as follows:

$$\Delta H_{process} = e_{reform}\Delta H_{reform} + (1 - e_{reform})\Delta H_{combust} + \left(\frac{1}{3}e_{reform}\right)\Delta H_{WGS} + \left(\frac{8}{3}e_{reform} - 2\right)\Delta H_{phase}$$

$$\Delta G_{process} = e_{reform}\Delta G_{reform} + (1 - e_{reform})\Delta G_{combust} + \left(\frac{1}{3}e_{reform}\right)\Delta G_{WGS} + \left(\frac{8}{3}e_{reform} - 2\right)\Delta G_{phase}$$

If we choose all the extents of reaction for the reforming reaction (e_{reform}) between 0 and 1, the design constraints will reduce the area of Figure 3.10 to a single line, which is shown in Figure 3.11.

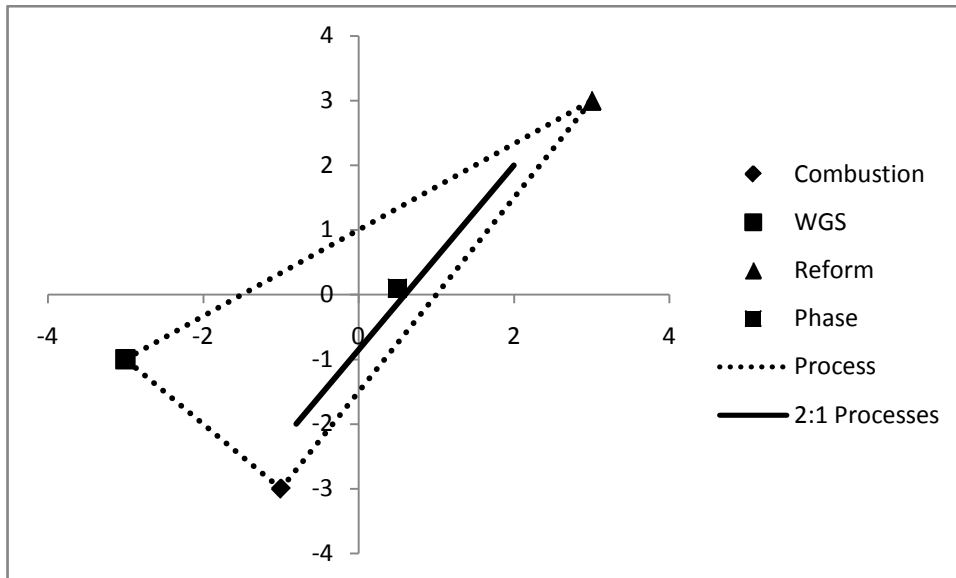

Figure 3.11: All possible steam reforming processes that produce 2:1 syngas product, shown within the overall material balance area

Figure 3.11 illustrates the operating line for all the possible steam reforming processes that can produce a syngas product that meets the 2:1 $H_2:CO$ product specification, and shows how these 2:1 processes lie within the overall material balance area. (It should be noted that Figure 3.11 is not drawn to scale.)

The area of possible operating points for a steam reforming process has now been reduced to a single straight line by limiting the material balance to a desired product specification. However, before a flow sheet can be developed, we must select a single operating point on the 2:1 operating line. This we can do more conveniently if we draw the 2:1 process line of Figure 3.11 to correct scale, producing Figure 3.12.

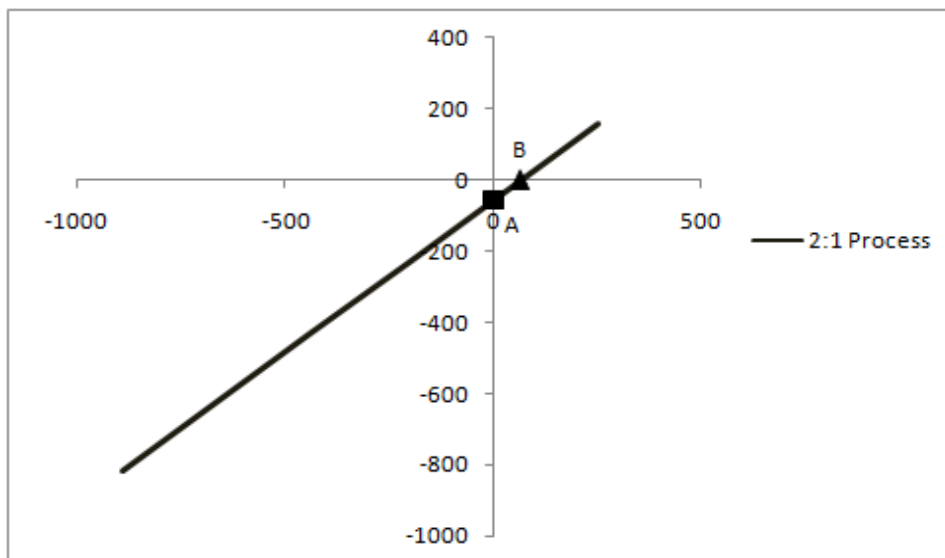

Figure 3.12: Processes meeting 2:1 specification with the extent of the reforming reaction varying between 0 and 1

The line in Figure 3.12 represents all the possible extents of reaction that could produce a syngas product to the desired specifications. It differs from Figure 3.11 in that it is drawn to the correct scale, with the actual values of the mass and energy balances. In principle, a plant could be designed to operate at any point on the line.

3.3.2.1 Feasible operating points on the Figure 3.12 continuum

What if a position in the positive ΔH and ΔG quadrant (to the right of B in Figure 3.12) was chosen as the operating point? This would represent a process that requires both heat and work. We have already shown that the only available source of heat is the combustion reaction, so choosing to operate in the positive quadrant is not a desirable option because combustion does not supply sufficient heat.

By the same reasoning, electing to operate between the points A and B is also not advisable. The process in this case produces work, but still needs heat to proceed.

If the process designer chooses to operate at any point to the left of A (in the negative ΔH and ΔG quadrant), the result would be a process that produces both heat and work. In theory such a process would be functional; but it is not the best option, because it produces too much heat and work. As already noted, the only source of heat and work is the combustion reaction, so that, if too much heat and work is being produced, the extent of that reaction is too great. Operating at such a point is wasteful in terms of energy, and generates excessive amounts of carbon dioxide.

This leads to the conclusion that the best point at which to operate the process is at A itself. *At point A the process produces work but no heat.* Put in other words, by extension of design constraint 3, *the best operating point for the process is an adiabatic process.* Therefore from this point onwards, the operating point of the overall process must always be adiabatic.

It follows that choosing an extent of the reforming reaction ($e_{reform} = 0.78$) such that the process is overall adiabatic, makes it possible for the designer to determine the process material balance and draw the first postulate flow sheet, as shown in Figure 3.13.

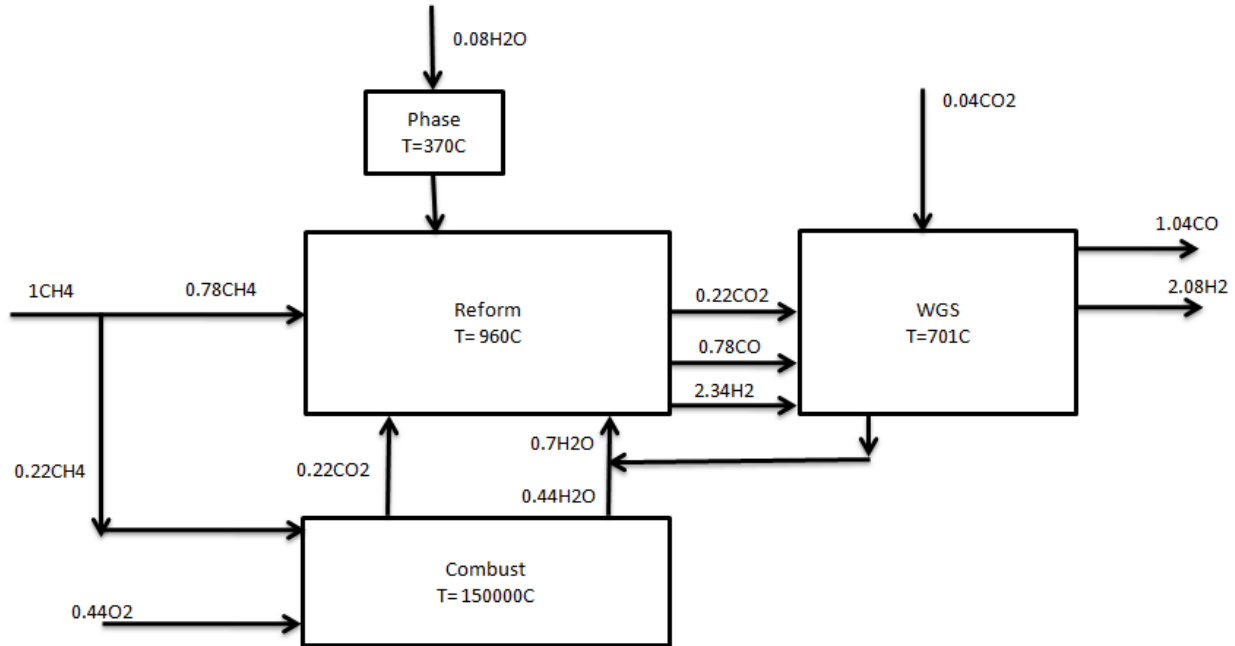

Figure 3.13: Postulate reformer flow sheet 1 using process Carnot temperatures

The above represents a reformer flow sheet that displays each of the 4 reactions in its own unit at Carnot reaction temperature (hypothetically, at least), in which the work is carried with the heat, at atmospheric pressure. The operating point of Figure 3.13 is A on Figure 3.12.

The split in the methane feed stream is a result of the design constraint introduced with the material balance, in terms of which the reforming and combustion reactions must share a single unit of methane. The water “recycle” stream leaving the WGS unit is necessary because the WGS unit produces some water during its reaction. This water can be added directly to the reform unit, but if this water is removed from the process instead, the material balance done in the previous section will change. Recycling the water would make the best use of the mass flows available.

This process is adiabatic and produces pure components, excess work and a carbon efficiency of 104%. The latter is determined by the amount of carbon fed to the process over the amount of carbon that leaves the process as a desired product (carbon monoxide, in this case).

There is a flow of mass, heat and work between the units. Figure 3.14 below, represents these different flows with heat as solid lines, work as dashed lines, and mass flows as light solid lines.

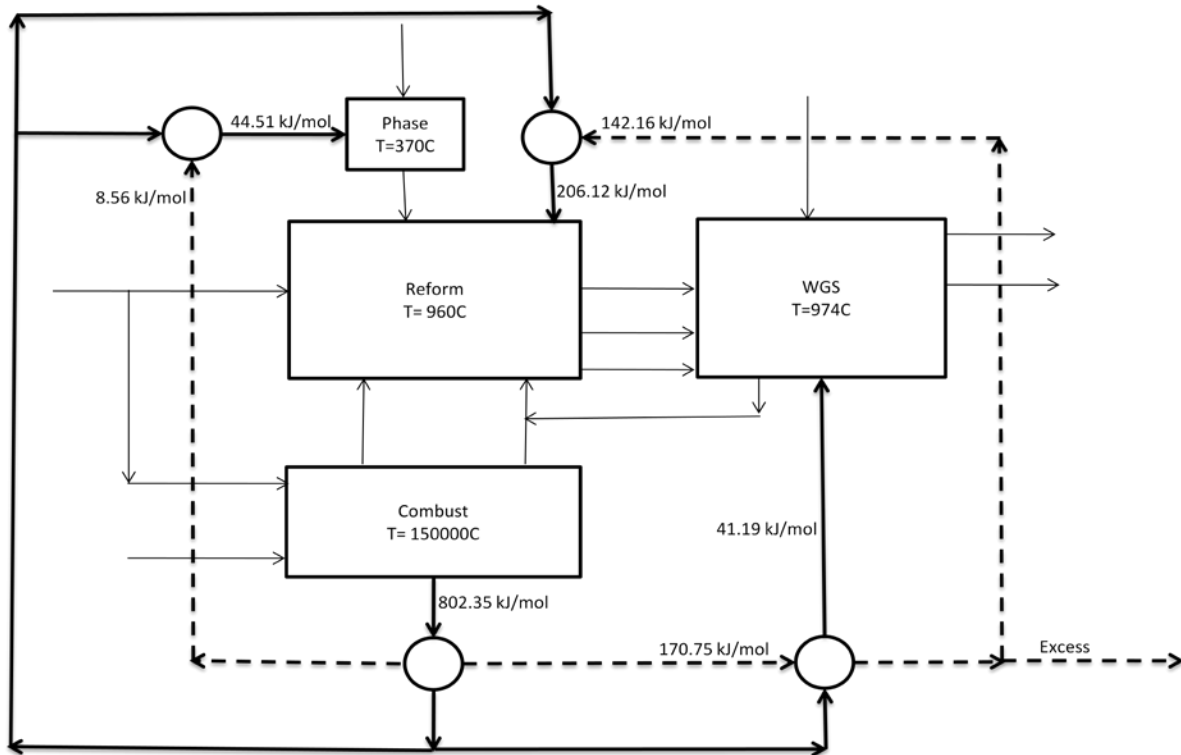

Figure 3.14: Mass, Heat and Work flow for postulate flow sheet 1

Figure 3.14 shows that all the energy requirements for the process are provided by the combustion unit. Since the process is overall adiabatic the combustion unit provides exactly the right amount of heat for the other process units and the excess work must be rejected from the process in some manner.

A brief examination of Figure 3.13 and Figure 3.14 should make it clear that the Carnot temperature for the combustion reaction is neither feasible nor realistic/practical. It is also not a realistic solution to consider the production of pure components, since the products from the reaction units cannot separate themselves. Additionally, the excess work produced by the process should be recovered as real work, to prevent its being lost.

The operating point of the process depicted in Figure 3.13 and Figure 3.14 is still the A of Figure 3.9, which is to say that the process continues to be adiabatic and work-producing.

Note also that the WGS reaction was defined earlier as an equilibrium reaction, but has not been treated as such in Figure 3.13.

This train of reasoning leaves 4 issues that require resolution before a more complete flow sheet can be designed (or any attempt at simulation made). These issues are set out in the order we propose to address them in the paper: WGS equilibrium, operating temperature, pure component production and work recovery. The ordering is logical. Equilibrium and operating temperatures are parallel considerations, and are therefore dealt with simultaneously. Work recovery should be addressed last, since the resolution of all the other issues will have an effect on the amount of

work that needs to be recovered, following the maxim that *how much* work requires recovery needs to be known *before* it can be recovered. Again, because the full material balance must be known before mixing and separation requirements can be established, this issue is discussed after temperature modification but before work recovery.

3.3.3 Selection of operating temperatures

Figure 3.13 above showed that the Carnot temperature of the combustion reaction would not be practicable operationally. It is therefore necessary to modify the temperatures.

The process depicted in Figure 3.13 produces work at rate of 56kJ/mol. However, Figure 3.6 demonstrates that changing the operating temperature has an effect only on the ΔG of the process. This means that altering the temperature will affect only the amount of work the overall process will produce/require and not the quantity of heat.

In order to ensure that the reforming reaction proceeds to completion (that is, no methane leaves the reforming reactor), the designer needs to ensure that the reaction occurs at above 800°C. Below this temperature the equilibrium conversion of methane in the reformer is not 100%, which means that additional separations will be needed to deal with the unreformed methane. The GH-space is capable of dealing with an incomplete methane conversion, but a preferable solution would be to avoid producing any excess methane.

As we will show at a later stage, the chosen operating temperature can be treated as a degree of freedom. Any temperature above 800°C could be used: we have selected a reformer temperature of 1000°C to make absolutely sure there is no unreformed methane. This is higher than the thermodynamic complete conversion temperature and below a temperature where the materials of construction will start to become a severe problem and is also in the range of existing methane reforming processes.

Since reforming and combustion both use the same mole of methane feed, 1000°C may also be a reasonable temperature at which to perform the combustion reaction. This is analogous to preheating reactor feeds to the reaction temperature.

The temperature change does not affect the material balance shown in Figure 3.13, so the proportions of the reactions required to produce an overall adiabatic process remain the same. What differs is the amount of excess work produced by the process. This alters the amount of work that could be lost, which in turn would affect how irreversible the process is.

ΔG can now be recalculated for the 3 reactions, starting with the reaction extents from Figure 3.13 and Figure 3.14 and the new operating temperatures, using Equation [5].

Before the flow sheet can be redrawn, we must select an operating temperature for the WGS reactor. To ensure that the WGS reaction proceeds to a sufficient extent of reaction (as required by the material balance), we have to carry out equilibrium calculations.

From the analysis we carried out prior to plotting Figure 3.13, we know the desired extent of the WGS reaction. That extent is part of what makes the process adiabatic overall, and produces syngas in the desired ratio. We can use our previous calculations to determine an operating temperature that provides that extent.

Knowing that extent, it is possible to determine an operating temperature that will create an equilibrium that will provide that extent.

The WGS reaction is:

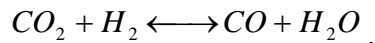

The equilibrium constant is given by:

$$K = \frac{(CO)(H_2O)}{(H_2)(CO_2)} \quad [9].$$

Since the ratio of hydrogen to carbon monoxide is 2:1, Equation [9] reduces to:

$$K = \frac{(H_2O)}{2(CO_2)}$$

Equation [9] can easily be written in terms of the material balance around the WGS reaction of Figure 3.13. A simple alternative would be to write Equation [9] in terms of the extent of the reform reaction, using the material balance method shown in Section 3.3.2.

The equilibrium constant is also given in terms of temperature by the Van't Hoff equation:

$$\frac{d \ln K}{dT} = \frac{\Delta H_{rxn}^0}{RT^2} \quad [10],$$

where:

- ΔH_{rxn}^0 is the enthalpy of the WGS reaction as calculated by Equation [2]
- R is the gas constant
- T is temperature
- K is the equilibrium constant.

So, assuming a constant ΔH_{rxn}^0 , the equilibrium is given in terms of the material balance and the temperature. By using Equations [9] and [10] appropriately, we can determine the temperature required for a certain extent of reaction, or, conversely, the equilibrium extent for a given temperature.

This can be drawn onto a graph of extent against temperature, as can be seen in Figure 3.15.

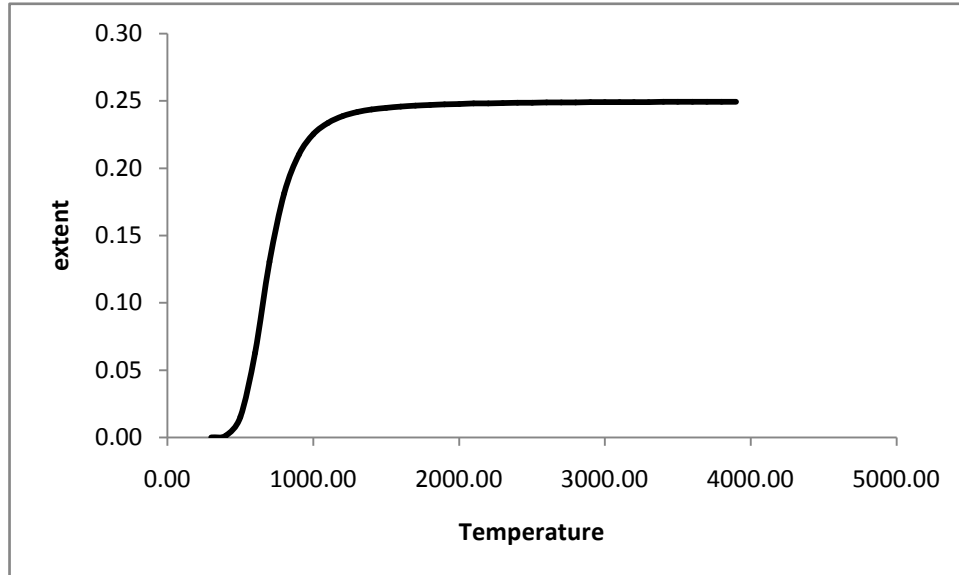

Figure 3.15: Equilibrium extent and temperature for WGS reaction. By material balance the required $e_{WGS} = e_{reform}/3 = 0.26$

Figure 3.15 shows that the extent of the WGS reaction asymptotes at 0.25. In other words, no matter how high the temperature, the extent of the WGS equilibrium never exceeds 25%.

However, Figure 3.13 indicates that the extent of the WGS reaction **needs** to be 0.26. According to Figure 3.15 the maximum possible extent is 0.25. This means that the required extent of reaction of 0.26 cannot be accomplished merely by increasing the temperature.

We carried out the equilibrium calculation set out below using only what was already available within the system (which is defined by the mass, energy and work balance that lead to an adiabatic process overall). Le Chatelier's Principle holds that changing the amounts of feed or product can alter the equilibrium. In this case the latter are set by the product specification, and the hydrogen feed to the WGS reactor is fixed by the reform reaction. The only other way to increase the extent of the WGS reaction to the desired level is, therefore, to increase the carbon dioxide feed to the WGS reactor.

This means there is an additional degree of freedom. The greater the excess carbon dioxide that is added, the lower the necessary reaction temperature will be.

If the carbon dioxide added is defined as a quantity X, then Equation [9] will become:

$$K = \frac{(H_2O)}{2(X + CO_2)}$$

As mentioned earlier, the Carnot temperature, shown to be 701°C (974K) in Figure 3.13, would be the operating ideal, although catalyst operating temperature may affect the choice of

temperature. As we know the desired temperature and the required extent, we are able to calculate the amount of carbon dioxide (X) that should be added.

After modifying the reaction temperatures and considering the equilibrium of the WGS reaction, the postulate flow sheet now becomes:

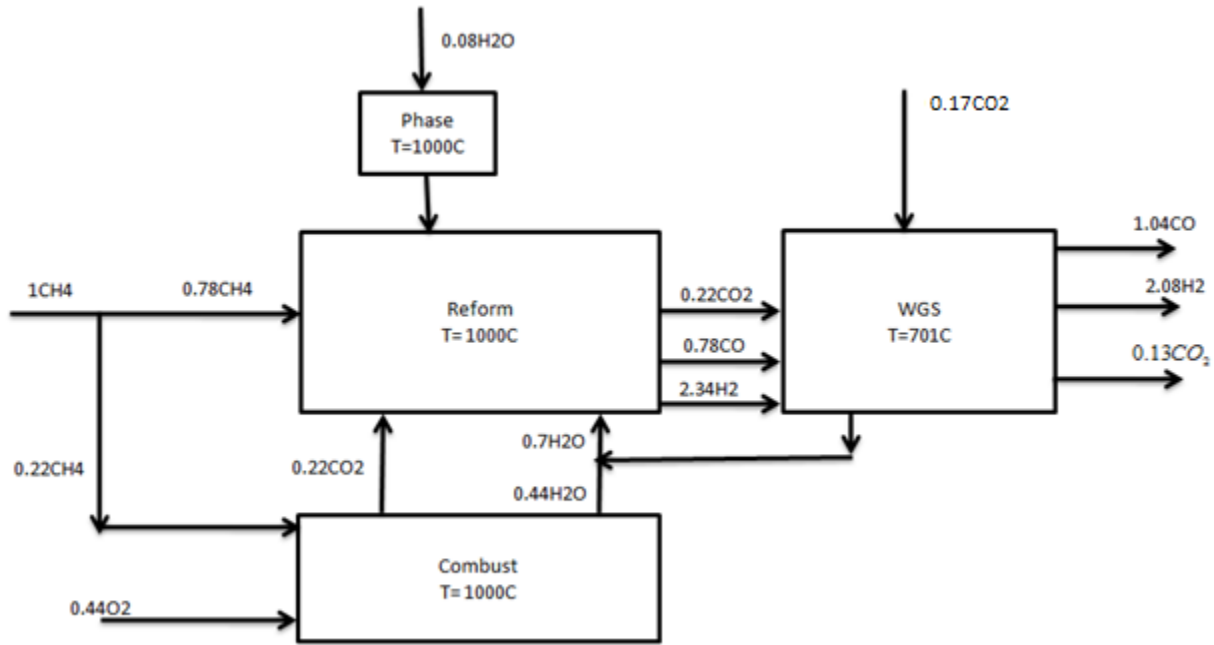

Figure 3.16: Postulated flow sheet 2 for modified operating temperatures.

Figure 3.16 shows the flow sheet modified for more reasonable operating temperatures. This process is still adiabatic overall, is a *net* consumer of carbon dioxide, and produces work at approximately 2kJ/mol. The mass and energy balances have not been affected; only the work balance has changed. This means that the flow sheet in Figure 3.16 is still operating at the point A of Figure 3.12 but it has now moved vertically along the ΔG axis, changing the amount of work that needs to be recovered.

Figure 3.16 does not represent the most efficient way to draw the flow sheet. Because the reform, combust and phase units all operate at the same temperature, we could put these 3 reactions into a single unit and call it the reformer. Another aspect of Figure 3.16 worthy of note is that the WGS reactor is emitting less carbon dioxide than it is being fed. It might therefore be preferable to reuse the carbon dioxide that is being vented, and make up the carbon dioxide that was consumed in the WGS reaction with a fresh flow of carbon dioxide.

Making these changes results in a new flow sheet, Figure 3.17.

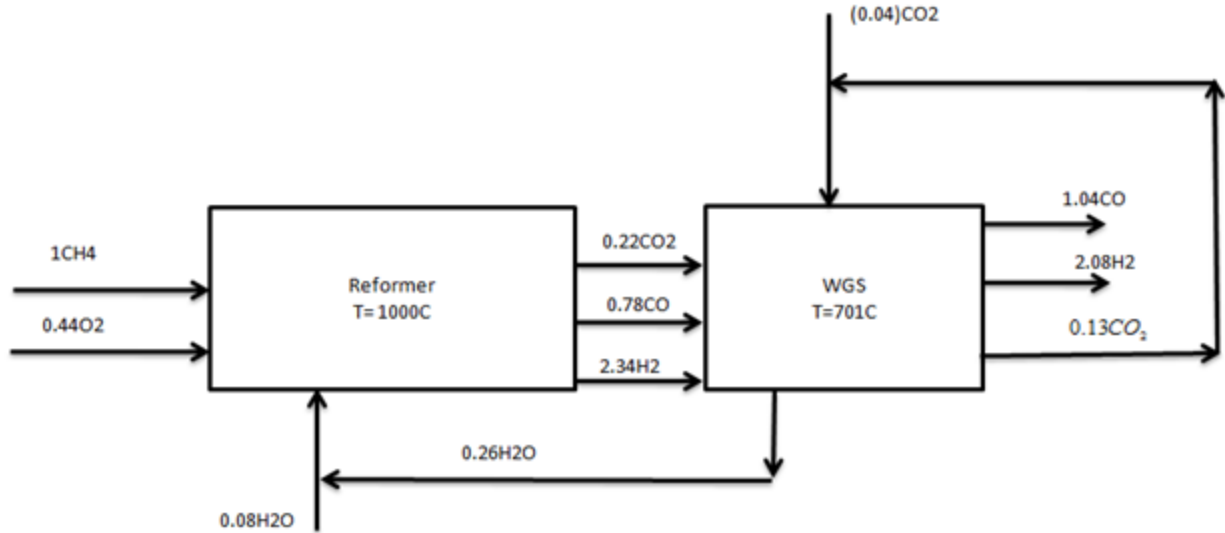

Figure 3.17: Combined flow sheet taking into account operating temperature and process mass integration

The above is a reproduction of Figure 3.16, but with the carbon dioxide recycle added and the reform, combust and phase reactions combined into a single unit. This process remains adiabatic, work-producing and carbon dioxide-absorbing, since the overall material balance of the flow sheet has not changed.

In order to be able to recycle water and carbon dioxide these components must be separated. This forms the subject of the next section.

3.3.4 Pure components: mixing and separation

Having considered the effect of operating temperature on the flow sheet, we turn our attention to the mixing and separation of components.

In Figure 3.16 and Figure 3.17, the streams leaving the 2 reactors will be mixtures and not pure components. We will consider 2 instances of mixing: that of the products leaving the reformer and that of those leaving the WGS. This mixing can be handled as a vector with a magnitude defined by Equation [8], as is illustrated in Figure 3.18 below. The compositions in Equation [8] are given by the mass balance and the temperature is given by the choice of reaction temperature thus ΔG_{mix} can be calculated.

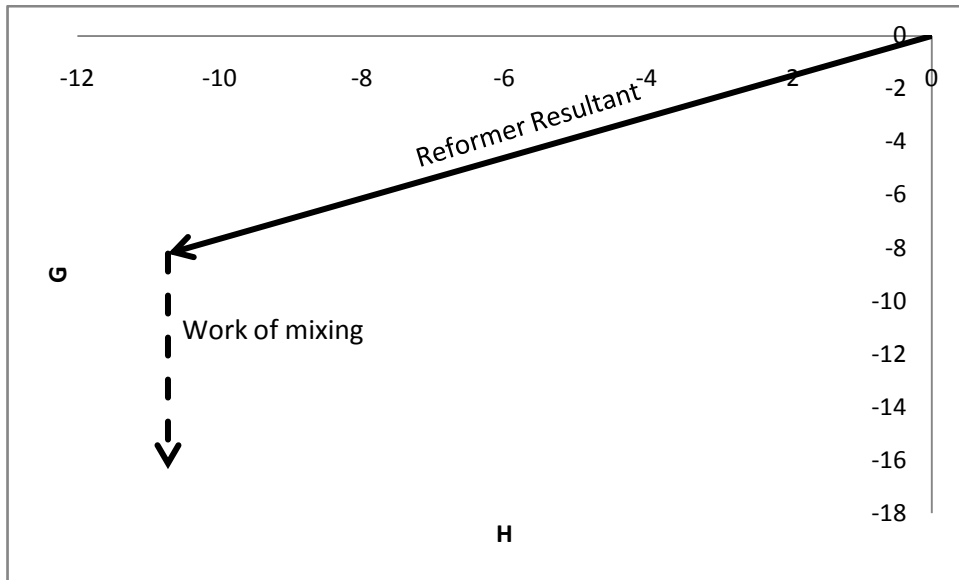

Figure 3.18: The pure component reformer unit resultant vector being added to the mixing vector

The direction of the mixing vector will always be vertical, since there is no enthalpy of mixing in the case of ideal mixing. It will also point in a negative direction (downward), since mixing is the opposite of separation. (Separation has a positive—upward—direction, because separation almost always requires work, it rarely occurs spontaneously.)

Similarly, we have to separate the mixture leaving the WGS reactor into separate streams of water, carbon monoxide and syngas product in order to recover the excess products for Figure 3.17.

As in the case of temperature modification, the mixing/separation terms have no effect on the proportion of the reactions needed to create an adiabatic process overall, so the material balance remains unchanged. What does alter is the amount of excess work that the process will produce. Mixing will increase it, while separation will decrease it.

After performing the vector additions, we can draw the next postulate flow sheet, Figure 3.19.

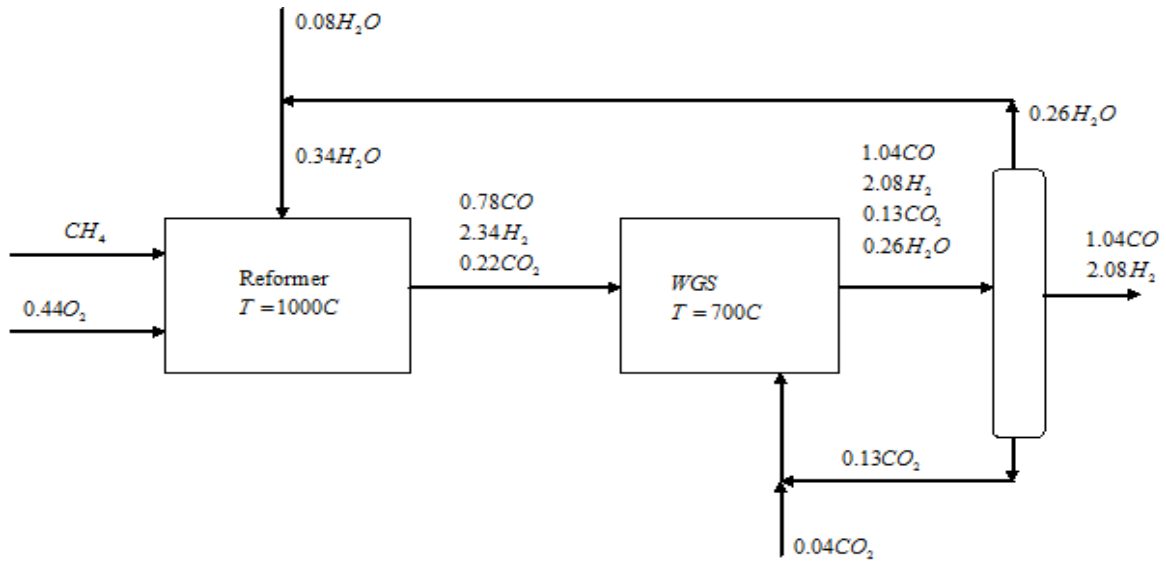

Figure 3.19: Postulate flow sheet 3 with the inclusion of mixing and separation

Figure 3.19 shows a flow chart in which all the mixing and separation terms have been taken into account. As in all the previous flow sheets this process remains adiabatic and carbon dioxide-consuming. What is different from Figure 3.18 is that the amount of work that the process in Figure 3.19 produces is approximately 14kJ/mol.

3.3.5 Work recovery

Thus far we have shown that all the flow sheets produce amounts of work that vary according to the operating temperatures and whether the effects of mixing and separation are incorporated. The excess work released from the process needs to be recovered in some way. Failing that, the work will simply be lost to the environment. The best way to recover this work would be via shaft work, which, in the case of generators, would take the form of electricity.

However, up to this point we have given no consideration to pressure, which, as previously discussed, provides a means of adding or removing work from a process.

The calculations leading to Figure 3.18 revealed how much work would need to be recovered from the process. We have also defined the material balance for the process. That means we can use Equation [7] to determine the only unknown quantity remaining, the pressure.

Equation [7] leads to the finding that a pressure of 8.8 atmospheres would allow the recovery of the excess work generated by the process depicted in Figure 3.19.

This allows a final flow sheet, Figure 3.20, to be drawn.

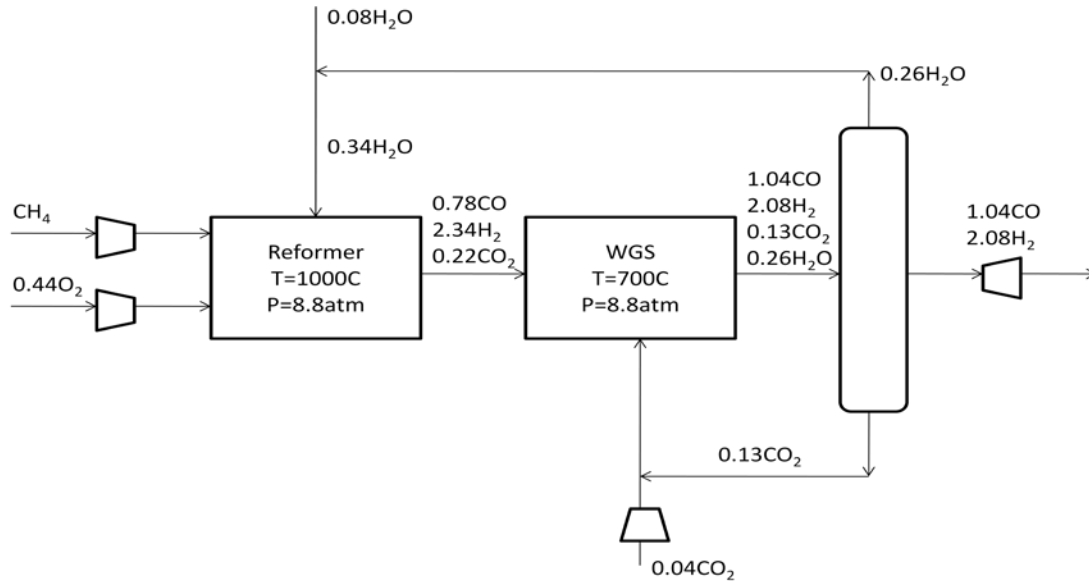

Figure 3.20: Near reversible steam reforming process with work recovery

The process shown is adiabatic overall, has a carbon efficiency of 104%, generates electricity and operates at the reasonable pressure of 8.8 atmospheres.

The placement of the final turbine in the process raises an interesting design problem. This turbine can be placed after the separator, as it has been in Figure 3.20. Alternatively, the turbine can be positioned before the separator. While placing the turbine before the separator will allow the work recovery to occur at a slightly lower pressure, due to larger change in gas moles, in the end the choice will come down to whether or not a pressurized separation is worthwhile or sensible, since the total work recovered from the system in either case will be the same.

Using the flow sheet in Figure 3.20, we can now illustrate the heat and work flows within the process. This can be seen in Figure 3.21.

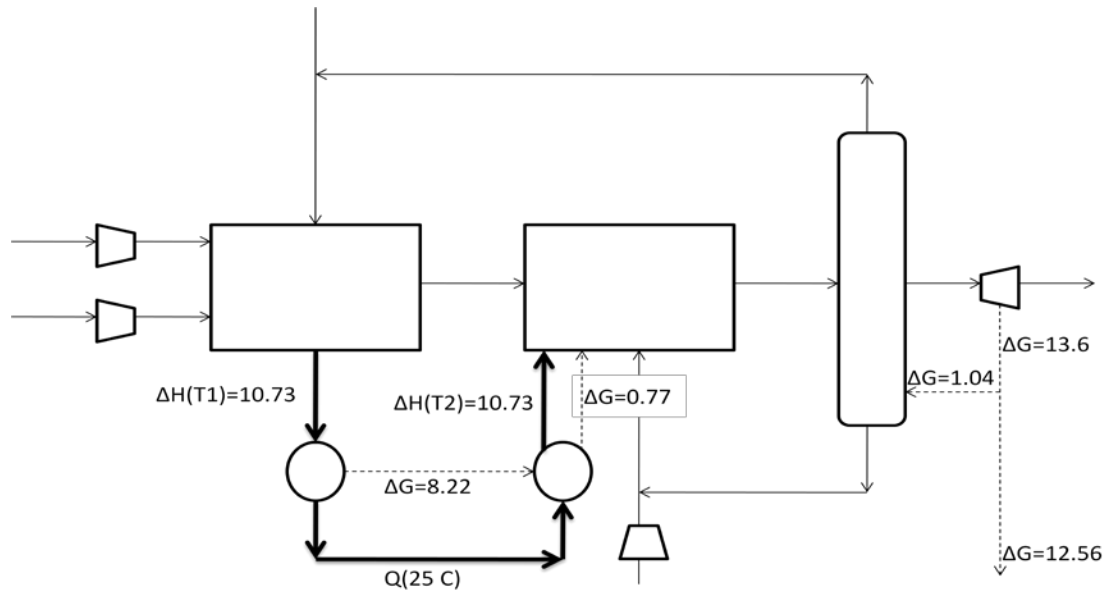

Figure 3.21: Flow of heat (thick solid lines) and work (dashed lines) for Flowsheet, Figure 3.20

Figure 3.21 is identical in mass flow to Figure 3.19, but also shows the flow of heat and work within the process. Heat is represented by the thick, work by the dashed and mass by the thin lines.

As can be seen, the first reactor (reformer) is exothermic. By virtue of its temperature the heat leaving the reformer carries work with it. The heat is transferred to the endothermic WGS reactor, but at a different temperature. This means that the work made available by the reformer heat is greater than the work required by the WGS reactor, creating an excess. Along with the additional work generated by mixing, this excess is recovered, by means of pressure, to generate electricity in a turbine.

The recovery of excess work is accomplished by integrating the feed compressors with the product turbine. Work is required to increase the pressure of the feeds, whereas work is recovered by decreasing the pressure of the products through a turbine. Since the amount of gas leaving the process is greater than the amount that enters that process, the amount of work recovered by the turbine is greater than that required by the compressors. The turbine can provide the work to operate the compressors, and the excess could then be connected to an electrical generator, or used for some other purpose.

3.3.6 Simulation in ASPEN Plus

Up to this point, we used the graphical technique to create the flow sheets. We can then begin entering these specifications into a simulator to investigate whether there was any agreement between the simulator's calculations and those we used to apply the graphical technique.

Having selected the widely-used chemical process simulator ASPEN Plus, we introduced the process shown in Figure 3.19 as input.

The model we chose for the reformer reactor was RSTOIC, which is simply a stoichiometric reaction model. It was unnecessary to use a more sophisticated version because in making our original calculations we assumed that the temperature was high enough for reaction to occur to completion. The equilibrium calculations were verified with the simulator and they were both in agreement.

For the WGS reactor we used an RGIBBS model, which utilizes the technique of finding the equilibrium by locating the minimum Gibbs-free energy in the reactor. The equilibrium calculations that were carried out in the development of Figure 3.19 made use of a slightly different technique, but the results were expected to be similar.

When creating the ASPEN flow sheet, we needed to take special care to make allowance for the assumption that the products and feeds of each reactor should be at the same temperature. We also noted that the treatment of the phases of water at certain temperatures could cause problems.

Having addressed these issues, we ran the simulation.

The result of the simulation was a perfect agreement in the material balance of the simulation and flow sheet. In terms of the energy flows, the simulation flow sheet was very slightly exothermic (about 300W), whereas the manual flow sheet was adiabatic. The discrepancy is small, however, and could be attributed to issues like differences in the thermodynamic data used.

3.4 Conclusion

In this paper we have shown how the flows of heat and work can be used to design a thermodynamically optimal flow sheet for a process. The method described in this paper can be applied to any process, of any complexity, on a simple 2-dimensional set of axes.

This process flow sheet depicts a process that has a **carbon efficiency of 104%**, is **adiabatic** (provides its own heat) and **produces work as electricity**.

By starting with a simplistic case and adding ever-increasing complexity, we improved the flow sheet progressively to the point at which it could be presented in this paper.

In Table 3.1 below, we show the steps in flow sheet development, along with the potential losses of work if it is not recovered.

Table 3.1: Summary of lost work with increasing process complexity

Figure Number	Excess Work (kJ/mol)	Comment
3.13	56.17	Impossible Operating Temperature
3.17	2	Ideal case. No mixing or separation considered
3.20	14	Work recovered with compression

Perhaps the greatest advantage of the flow sheet depicted in Figure 3.20 is that it is a carbon dioxide absorber, as the process uses CO₂ as a feed stock.

Given the design constraint that the process must be adiabatic overall, a carbon efficiency of 104% represents the theoretical thermodynamic limit for this synthesis gas production. However, syngas production is typically only one step within a larger process (Syngas being fed into Fischer-Tropsch or methanol synthesis or the hydrogen being used in ammonia synthesis).

It seems possible that supplying too much oxygen to the reformer unit can cause inefficiencies, in that it would allow the combustion reaction to proceed too far, leading to losses in heat and, by extension, work. Additional inefficiencies might arise from practical considerations such as limitations in construction materials.

The flow sheet, Figure 3.20, represents an ideal, what the best possible flow sheet might look like. It provides a basis from which new processes may be developed, and existing processes improved.

The GH-space is a tool that allows the designer to interpret processes and identify major losses. This provides the designer with a valuable indicator of the modifications that should be made to improve the efficiency of the process under scrutiny.

The technique demonstrated in this paper is a departure from the traditional method of designing and optimizing a process, one unit at a time. Instead we have proposed that it may be better to consider a process in terms of the *interactions* of all the units together, so that it can be designed and optimized as a whole.

References

1. Floudas, C. A and Kokossis, A. C. (1990) Optimization of Complex Reactor Networks-I. Isothermal Operation. *Chemical Engineering Science*. **45**(3), 595-614
2. Floudas, C. A. and. Kokossis, A. C. (1994) Optimization of Complex Reactor Networks-II. Non-Isothermal Operation. *Chemical Engineering Science*. **49** (7), 1037-1051
3. Peschel, A., Freund, H., Sundmacher, K. (2010) Methodology for design of optimal chemical reactors based on the concept of Elementary process functions. *Ind. Eng. Chem. Res.* **49** (21), 10535-10548
4. Kokossis, A.C. and Briones, V. (1999) Hypertargets: A Conceptual Programming approach for the optimisation of industrial heat exchanger networks-I. Grassroots design and network complexity. *Chemical Engineering Science*. **54** (4), 519-539
5. Kokossis, A.C. and Briones, V. (1999) Hypertargets: A Conceptual Programming approach for the optimisation of industrial heat exchanger networks-II. Retrofit Design. *Chemical Engineering Science*. **54** (4), 541-561
6. Kokossis, A.C. and Briones, V. (1999) Hypertargets: A Conceptual Programming approach for the optimisation of industrial heat exchanger networks-III. Industrial Applications. *Chemical Engineering Science*. **54** (5), 685-706
7. Floudas, C. A. and Anastasiadis, S.H. (1988) Synthesis of distillation sequences with several multicomponent feed and product streams. *Chemical Engineering Science*. **43**(9), 2407-2419
8. Ruiz, G.J., Kim, S.B., Moon, J., Zhang, L., Linninger, A.A. (2010) Design and Optimization of energy efficient complex separation networks. *Computers and Chemical Engineering*. **34**(9), 1556-1563
9. Li, L-J., Zhou, R-J., Dong, H-G., Grossman, I.E. (2011) Separation Network Design with mass and energy separating agents. *Computers and Chemical Engineering*. **35**(10), 2005-2016
10. Mahalec, V. and Motard, R. L. (1977) Procedures for the Initial Design of Chemical Processing Systems. *Computers and Chemical Engineering*. **1**(1), 57-68
11. Westerberg, A.W. (2004) A Retrospective on Design and Process Synthesis. *Computers and Chemical Engineering*. **28**(4), 447-458
12. Raju, A.S.K., Park, C.S., Norbeck, J.M. (2009) Synthesis gas production using steam hydrogasification and steam reforming. *Fuel Processing Technology*. **90** (2), 330-336

13. The National Hydrogen Association website. 2004. Hydrogen Production Overview. http://www.hydrogenassociation.org/general/factSheet_production.pdf Accessed March 2009.
14. Shadel, B.C., Duisberg, M., Deutschmann, O. (2009) Steam Reforming of Methane, Ethane, Propane, Butane and Natural Gas over a Rhodium based catalyst. *Catalysis Today*. **42** (1-2), 42-51
15. Escritori, J.C., Dantas, S.C., Soares, R.R., Hori, C.E. (2009) Methane Autothermal Reforming on nickel-ceria-zirconia based catalysts. *Catalysis Today*. **10** (7), 1090-1094
16. Wu, P., Li, X., Ji, S., Lang, B., Habimana, F., Li, C. (2009) Steam Reforming of Methane to Hydrogen over Ni-based metal monolith catalysts. *Catalysis Today*. **146** (1-2), 82-86
17. Rosen, M. A. and Dincer, I. (2001) Exergy as the confluence of energy, environment and sustainable development. *Exergy, An International Journal*. **1** (1), 3-13
18. Patel, B., 2007, Fundamental Targets for the synthesis and evaluation of chemical processes. Thesis, (PhD), University of the Witwatersrand
19. Sempuga, B.C., Hausberger, B., Patel, B., Hildebrandt, D., Glasser, D. (2010) Classification of Chemical Processes: A Graphical Approach to Process Synthesis to Improve Reactive Process Work Efficiency. *Ind. Eng. Chem. Res.* **49** (17), 8227-8237
20. Oaki, H. and Ishida, M. (1982) Study of Chemical Process Structures for Process Synthesis. *Journal of Chemical Engineering of Japan*. **15**(1), 51-56

Appendix A: Thermodynamic Property Data

	H (kJ/mol)	G (kJ/mol)
H ₂ O(l)	-285.83	-237.13
H ₂ O(g)	-241.82	-228.57
CO	-110.50	-137.20
CO ₂	-393.51	-394.36
CH ₄	-74.80	-50.79

Appendix B: Useful work of compression is equal to Isothermal Work

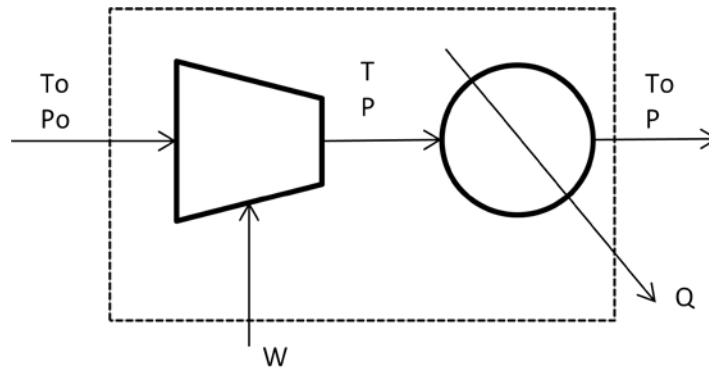

The diagram above shows a compression system. Material enters the compressor at the initial temperature and pressure, T_o and P_o .

Work is added adiabatically to the compressor where the temperature and pressure increase to T and P .

The material is then cooled by an amount Q to reduce the temperature back to T_o and at the pressure P .

An energy balance can be performed over the dashed block:

$$H_{in} + W = H_{out} + Q$$

Assuming that the enthalpy of the material in the system is not a strong function of pressure, which means the enthalpy of the material entering the system, is nearly equal to the enthalpy of the material leaving the system.

This reduces the energy balance to:

$$W = Q$$

An entropy balance can also be performed. Assuming a reversible system this becomes:

$$S_{in} = S_{out} + \frac{Q}{T_o}$$

And by definition:

$$G_{in} = H_{in} - T_o S_{in}$$

$$G_{out} = H_{out} - T_o S_{out}$$

Performing the necessary algebra reduces all this to:

$$W = G_{out} - G_{in}$$

Where:

- G_{out} is the Gibbs Free-Energy at pressure P and temperature T_o
- G_{in} is the Gibbs Free-Energy at pressure P_o and temperature T_o

This means that the useful work that increases the pressure is equal to the isothermal work. The excess work that is added during an adiabatic compression only increases the temperature not the pressure.

4 A Graphical Approach to flowsheet synthesis as applied to the Fischer-Tropsch system

Abstract

In this paper a novel approach to flow sheet synthesis is applied to the design of a flow sheet for the production of Fischer-Tropsch hydrocarbons. In most designs, mass and energy flows are analyzed. These flows of mass and energy must always balance, what differentiates different designs is how much of work and chemical potential flows are conserved.

A graphical technique, called the GH-space, uses the flows of heat and work inside a process to provide insight into the interactions of various process units from the very beginning of a design and in particular looks at where loss of work potential occurs.

Any unit process interacts with the environment by transferring heat and work and can be represented as a vector on the GH-space. By manipulating these vectors a process can be designed to meet certain design criteria or constraints.

In this paper five independent material balances (reactions) were defined. These were then used; together with vectors describing mixing, separation and pressure; to determine the overall mass, energy and work balances for the process before any flow sheet existed. These overall balances were then used to begin formulating the flow sheet.

It was shown that with careful manipulation of design variables a process could be designed that not only produced the desired product but also consumed carbon dioxide as a feed, along with feeds of methane and oxygen, and could potentially generate electricity.

While the GH-space technique is dynamic and flexible it tends towards the “best” thermodynamic solution. While it may not always be possible in a practical sense it allows a basis for more detailed design or for the modification of existing flow sheets.

4.1 Introduction

In previous papers on this work, by the authors,^{1,2} a technique was shown where the thermodynamic quantities of Enthalpy and Gibbs Free Energy could be used to develop flow sheets.

This technique considered the thermodynamic interactions of unit processes from the very earliest stages of design; breaking the mold of sequential design methodologies where such interactions are typically considered at the very end of the design, if they are considered at all.^{3,4}

The question then becomes, what is the importance of considering such interactions?

In recent years there has been increasing pressure on industries to have less impact upon the environment. While the issue is still largely a political one this concern will only continue to become greater as time goes on. In addition to environmental concerns it is also desired that industries to be as productive, efficient and profitable as possible.

The ability to meet all of these concerns will require great understanding and innovation on the part of the next generation of designers.

By considering the thermodynamic interactions from the earliest stages of design, steps can be taken to ensure that the heat and work within the process is put to the best possible use, minimizing the losses.

The significance of losses in heat and work has been described in the research and application of Exergy,⁵ which is the measurement of a systems departure from equilibrium with its surroundings. The greater these losses, the greater the exergy and the greater the impact on the surroundings.

There are multiple stages to process integration techniques. At the starting level is the “black box”, “global” or “systems level” approach where the emphasis is placed on the interactions of process units with each other.⁶ The graphical technique applied in this paper can be considered to follow this approach. This systems level approach begins by considering a process to have mass flows entering a process as feed material and leaving the process as product and then proceeds with a systematic method of designing the overall *layout* of the process. The minute detail of what occurs inside the process is the subject of later level integration techniques. Computer aided techniques has also been used in other research,⁷ where tools were presented that allowed for “systems level” optimization of heat exchangers, mass exchangers and other “in-plant unit operations”.

The next stage in process integration techniques involves investigating what actually occurs inside of the “black boxes” of the previous stage. This stage of research mostly involves the sequencing of specific unit process. Such as reactor sequencing,^{8,9} where emphasis was placed specifically upon optimizing the number, type, volume and configuration of the reactors inside of the “reaction box” defined by the previous stage of process integration. Other research,^{10,11} has

focused on the sequencing of separation units in order to fill the “separator” or “mass exchanger” box with a sequence of separators (such as distillation columns) in order to attain a desired separation in as cost effective a manner as possible. Additionally, attention has also been given to heat exchanger sequencing,^{12,13,14} where computer aided methods were utilized to network process heat exchangers in an optimal cost effective manner.

The next stage of process integration techniques follows from the previous stage in investigating what occurs within each of the optimized networks. The overwhelming majority of existing research focuses on improving the performance of reactor networks through the use of catalysis.^{15,16,17}

The value of all of this research is undisputable. However, there is a very real danger of applying some of these methods too soon while using sequential design methods. For instance, applying detailed reactor sequencing and catalyst selection too soon will likely place great strain upon the separation system when the time comes to design that section, perhaps making a truly efficient separation system impossible to attain.

In this way a process could potentially consist of a few highly efficient sections but a few highly inefficient ones as well, perhaps with the net result being less than what could potentially have been achieved had the interactions of all the process units been considered earlier.

The graphical technique that will be used in this paper, and from the previous papers by the authors, is used to find the “targets” for processes. By considering the mass, energy and work balances it is possible to find an attainable region for all possible processes. This attainable region can then be used to scan different designs which allow insight into where mass and energy are conserved but where work is not. The goal would then be to choose a design where this loss of work is minimized.

Any flow sheet developed by this technique is the best flow sheet attainable with a given set of assumptions and constraints. Naturally these may not be possible in reality, where compromises must always be made. However, by knowing what the target or best case is, compromises can be made with complete knowledge of the reasons.

This technique considers that the greatest innovation and impact on the performance of a process can be made before the layout of the process has even been decided. This is opposite from existing methodologies where layouts are chosen from the very beginning. The value of this graphical technique is that it provides a systematic method on designing a process layout rather than selecting a layout from a technology review which has the shortfall of automatically inheriting the strengths and weaknesses of the existing design which leaves little room for innovation.

In the previous papers by the authors the technique was applied to the design of synthesis gas generating process. Specifically by using Coal; considered to be pure carbon, and natural gas, considered to be pure methane.

The results of those papers showed that synthesis gas could be generated with much greater efficiency by using natural gas. It was also stated in those papers that the generation of synthesis gas is generally only one part of a larger whole.

One of the many uses of synthesis gas is for the production of hydrocarbons via the Fischer-Tropsch (FT) reaction, which have a vast variety of applications, such as polymers and fuels. This paper will go into further detail of creating a theoretical layout of a FT process that has the goals of minimizing the loss of work and to reduce the emissions of carbon dioxide.

4.2 Theoretical development of the Graphical Technique

4.2.1 A Simple Process

A simple process,¹⁸ is one where the feed and products of the process enter and leave at ambient conditions. As pictured in Figure 4.1:



Figure 4.1: A Simple Process

Energy and Work balances can be performed on this simple process. For instance, the energy balance would be given by:

$$\Delta H_{process}^0 = \left(\sum_i v_i \Delta H_{f,i}^0 \right)_{products} - \left(\sum_i v_i \Delta H_{f,i}^0 \right)_{reactants} \quad [1]$$

Where:

- v_i is the stoichiometric coefficient in the component i .
- The subscript f represents “of formation”
- The superscript 0 represents standard conditions.
- The subscript i represents species i

This is to say that ΔH , which is the net heat flow requirement of the process “ Q ”, is given by the difference of the Enthalpies of Formation of the products and feeds. This is because the products and feeds both enter and leave at ambient conditions, which removes the Enthalpy change due to Heat Capacity. This is often true for gases since Heat Capacities for gases are generally similar, making the enthalpy for gases a weak function of temperature.

Gibbs Free Energy is related to the work of the process “ W ”. Gibbs Free Energy for the simple process can be calculated by equation [2]:

$$\Delta G_{process}^0 = \left(\sum_i v_i \Delta G_{f,i}^0 \right)_{products} - \left(\sum_i v_i \Delta G_{f,i}^0 \right)_{reactants} \quad [2]$$

This means that a simple process actually needs to be drawn as in Figure 4.2 below:

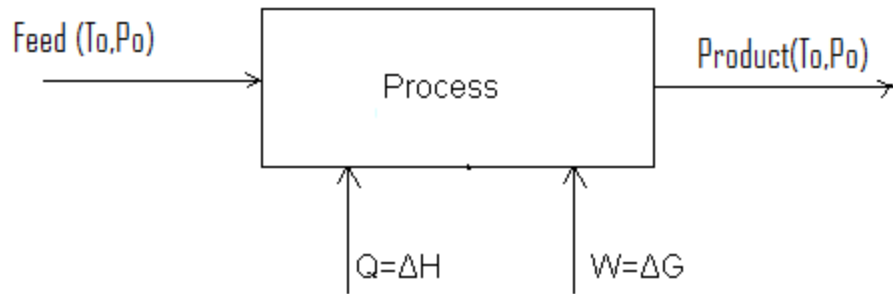

Figure 4.2: A Simple Process with the required heat and work

Figure 4.2 shows that any simple process will need to have a flow of heat and a flow of work. The direction of these flows will depend upon the nature of the process. For instance, in the case of reaction, endothermic reactions will have the flows into the process and exothermic reactions will have the flows out of the process. To elaborate further, Equations [1] and [2] describe the minimum quantities of heat and work that would be required for the process to occur. Conversely, Equations [1] and [2] could show the minimum amounts of heat and work that must be removed from the process.

4.2.2 Work Addition

Addition or removal of heat along temperature gradients is well understood. Addition or removal of work however bears further discussion.

It has already been established that the minimum work related to a process is given by the Gibbs free energy. Consider then, the fundamental equation for Gibbs free energy, equation [3]:

$$dG = -SdT + VdP + \sum_i \mu_i dN_i \quad [3],$$

where:

- μ_i is the chemical potential of species i .
- dN is the change in the number of moles of species i
- dT is the temperature change
- S is entropy
- V is volume
- dP is the change in pressure.

Perhaps the most important information contained in equation [3] is that there are only three ways in which work can be added, or removed, from a process: along temperature gradients, along pressure gradients and along chemical potential gradients.

It is immediately clear that the first method of work addition/removal has something in common with heat. They can both be added, or removed, by temperature gradients.

Heat has the ability to carry work with it by virtue of its temperature. Simply put, it could be said that heat at high temperature is more useful than heat at low temperature. This is the principle behind which engines work.

One way to show how heat carries work with it is by considering a heat engine, shown in Figure 4.3:

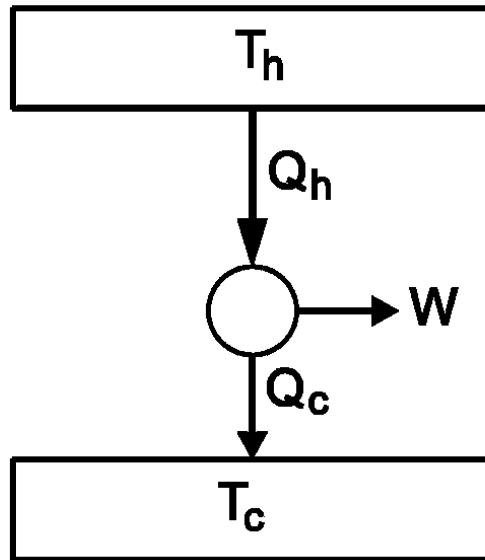

Figure 4.3: Heat engine showing the flow of work with heat

The well known Carnot Equation relates the work, heat and temperature by Equation [4]:

$$W = Q \left(1 - \frac{T_c}{T_h} \right) \quad [4]$$

Where:

- W is the Carnot work. $W = \Delta G$
- Q is the flow of high temperature heat. Note: $Q = \Delta H$ for a *process*
- T_c is the temperature of the cold reservoir
- T_h is the temperature of the hot reservoir

Figure 4.3 shows that the work produced by the heat engine flowed into the engine *with the high temperature heat*. A quantity of heat, Q_h , carries work with it by virtue of its temperature, T_h .

The quantity of work carried depends on the temperature of both the hot reservoir and the temperature of the cold reservoir.

Since heat and work can flow together the Simple process, Figure 4.2, could be drawn as Figure 4.4:

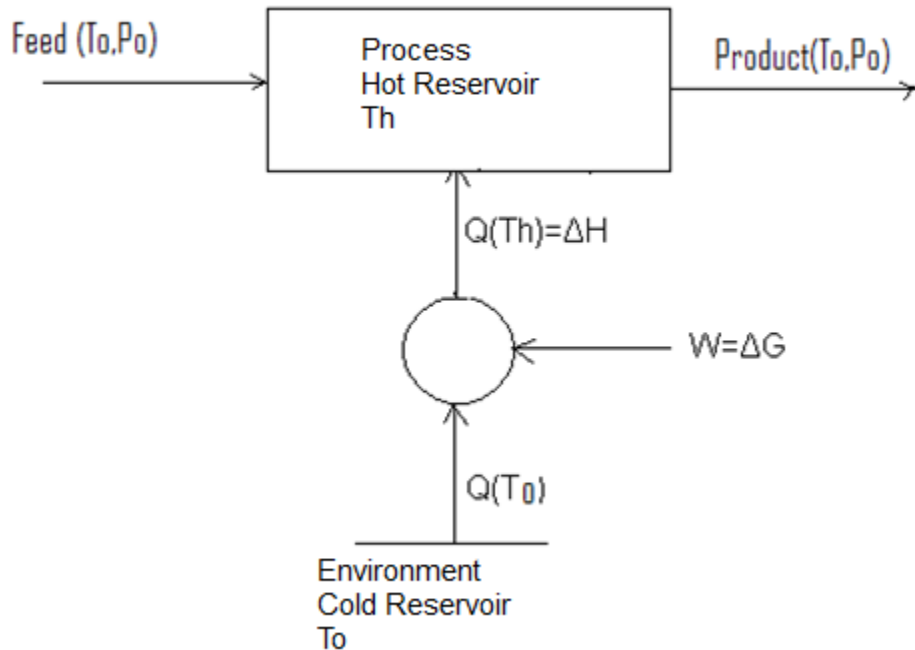
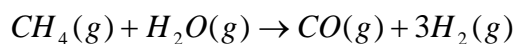

Figure 4.4: Simple Process with Heat and Work flowing together through a "heat pump"

Figure 4.4 shows the Simple Process of Figure 4.2 with a heat pump that allows the heat and work of the process to flow together. In this case the engine is referred to as a pump since the heat is flowing against the temperature gradient.

The hot reservoir is now the process itself and the environment is shown as being the cold reservoir. In general, the reservoirs depicted in Figure 4.4 need not be strictly the process and the environment. The cold reservoir could be another process, or the process could become the cold reservoir and the environment the hot such that the heat, Q_h , at a temperature, T_h , could effectively carry work with it. Thus if the design was done carefully, such as the process were a simple process. The heat Q_h would be equal to $\Delta H_{\text{process}}$ and, by choosing the correct temperature, the work associated with the heat would equal $\Delta G_{\text{process}}$.

Now consider the following example: The steam reforming reaction of methane as a simple process. The reaction in this process would be given by:



Using Equations [1] and [2] on the above reaction, the minimum heat and work requirements can be calculated and run through a simple process, as shown in Figure 4.5:

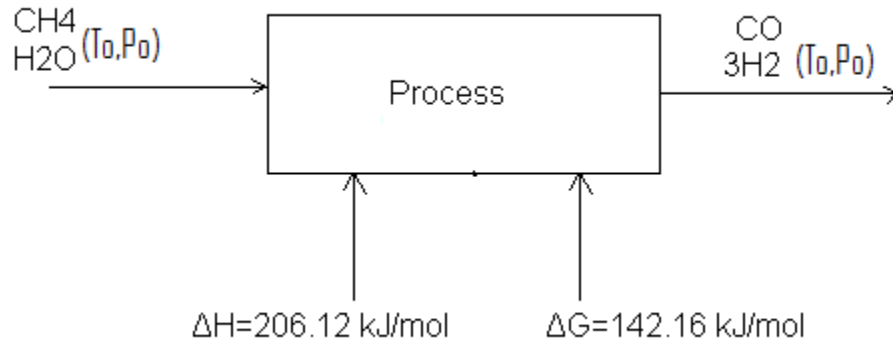

Figure 4.5: Methane Reforming as a Simple Process

Figure 4.5 shows that the steam reforming of methane is an endothermic process that requires 206 kJ/mol of heat and 142 kJ/mol of work in order to proceed.

As previously shown the heat can carry work with it by choosing the temperature of the process such that all the required work would be carried with the heat. Looking at Equation [4] it becomes clear that the required heat will carry all the required work at only one temperature.

This temperature has been named the Carnot Temperature of the simple process. It is the temperature at which the process could be run reversibly with a heat engine, as shown in Figure 4.6:

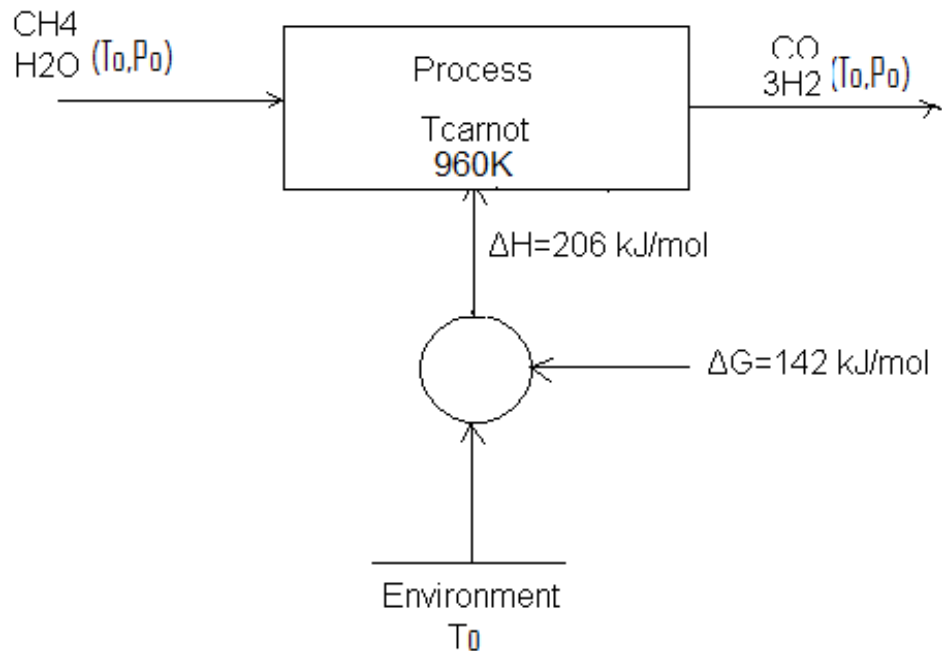

Figure 4.6: Reversible Reforming process at its Carnot temperature

The Carnot Temperature for the process of Figure 4.6 is 960K. If the methane reforming reaction were to be carried out at 960K the process would be reversible as a simple process and the heat will carry all the required work.

Since the heat flows in a process are generally significant it would be highly convenient if all processes were carried out at their Carnot temperatures since they would then be reversible without any other forms of work flow being necessary

However; the Carnot temperature is not always practical, or even possible, to use. Still considering the example of Figure 4.6; a temperature of 960K, while not completely ridiculous, may not be the most practical since temperatures below 1000K do not allow for complete methane reaction due to equilibrium considerations.

Calculations into some common combustion reactions show that the Carnot temperatures are physically impossible to attain. As an example, the combustion of Carbon in Oxygen has a Carnot temperature of -14000K. Which means Carbon combustion would never be reversible when only heat is used to carry the work.

In addition to equilibrium and physical practicality concerns, there are a host of other considerations that might influence the usefulness of the Carnot temperature, such as catalyst activity.

When the Carnot temperature does prove to be unworkable it means that heat alone cannot be used to carry the work. At this point one can return to the fundamental equation for Gibbs free

energy, Equation [3], and recall that there were 3 ways for work to be added or removed from a process.

The next method of work addition is by using pressure gradients. Work is added by increasing pressure and recovered by decreasing the pressure. For gases pressure is increased in a compressor and decreased in a turbine.

Consider the compressor system as shown in Figure 4.7 below:

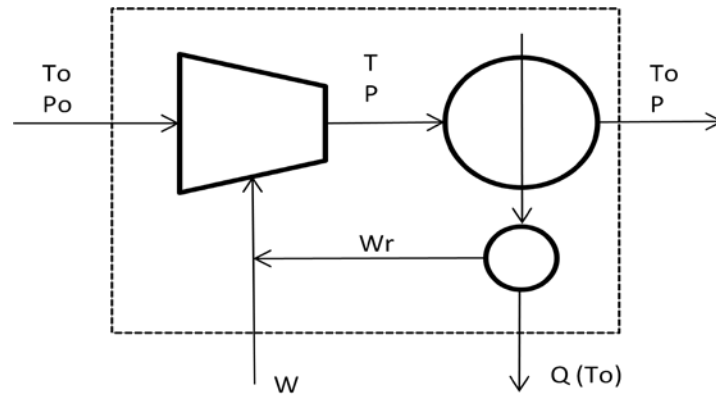

Figure 4.7: Compressor system with heat recovery

The compressor system in Figure 4.7 shows an adiabatic compressor, which increases the pressure and temperature of the stream, with some form of heat recovery afterwards, which returns the temperature of the stream to ambient conditions while maintaining the final pressure.

The assumptions used in the analysis that follows are: ideal gas (pressure has not effect on enthalpy) and reversibility (excess work can be recovered and integrated). The difficult assumption is the recovery and integration of excess work. This is difficult to do with real equipment, the excess work requirement can be designed for with the GH-space if desired but the purpose of this analysis is to show that the work used to increase the pressure is equal to the isothermal work and any excess above that isothermal work goes into increasing the temperature.

An energy balance can be performed over the system, represented by the dashed block:

$$H_{in} + W = H_{out} + Q$$

Assuming that the enthalpy of the stream being compressed is not a function of pressure, the enthalpy in and the enthalpy out will be the same and the energy balance will reduce to:

$$W = Q$$

Now assume that the system is reversible and perform an entropy balance:

$$S_{in} = S_{out} + \frac{Q}{T_o}$$

The energy and entropy balance we link via the quantity of heat rejected and we can therefore use Gibbs free energy to combine these balances. Thus:

$$G_{in} = H_{in} - T_o S_{in}$$
$$G_{out} = H_{out} - T_o S_{out}$$

With the necessary substitutions and simplifications all the above gives:

$$W = G_{out} - G_{in}$$

This appears to simply show what has been said throughout the paper: That the work is equal to the change in Gibbs free energy but it contains another important result when applied to compression.

The compressor in Figure 4.7 stugsis adiabatic but the overall system is isothermal. This shows that the *useful work of compression is equal to the isothermal work*. In other words, of the work that is added to an adiabatic compressor, the work that actually increases the pressure is equal to the isothermal work. All the extra work added in the adiabatic compressor only increases the temperature.

This additional work will be lost as heat, unless recovered in some other way.

Now it is possible to return to Equation [3] and examine the pressure gradient term more closely:

$$dG = VdP$$

Assuming an ideal gas and applying the ideal gas law:

$$dG = \frac{nRT}{P} dP$$

It has been shown that the useful work of compression is equal to the isothermal work. Assuming then that all compression and expansion is done isothermally the above equation can then be solved:

$$\Delta G = nRT \ln \left(\frac{P}{P_0} \right) \quad [5]$$

It is possible for the work to be calculated for the case of non-isothermal compression and expansion. Such results may still be applied to the graphical technique of this paper. In this paper the isothermal result will be used.

Returning to the Simple process of Figure 4.1 and adding compression and expansion to it, Figure 4.8 can be drawn:

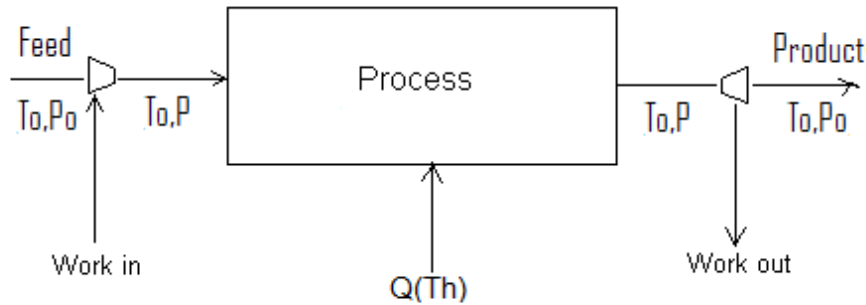

Figure 4.8: Simple process with compression and expansion

In Figure 4.8 work is added to the process at the Feed compressor and then recovered from the process from the product turbine.

The work added to the process and the work recovered from the process can both be calculated using Equation [5] above, and will be given by:

$$Work_{in} = \Delta G_{in} = n_{in} RT \ln\left(\frac{P}{P_0}\right) \qquad Work_{out} = \Delta G_{out} = -n_{out} RT \ln\left(\frac{P}{P_0}\right)$$

The sign convention used here and in the rest of the paper is work and heat streams entering the system are positive and ones leaving the system are negative.

The net effect of pressure gradient work would thus be the sum of both of the work terms, which leads to Equation [6]:

$$Work = \Delta G = (n_{in} - n_{out}) RT \ln\left(\frac{P}{P_0}\right) \qquad [6]$$

Where:

- n is the moles of gas entering (in) or leaving (out) the system
- R is the universal gas constant
- T is the compression temperature
- P and P^0 are the final and initial pressures respectively

The important result of Equation [6] is that increasing the pressure of a process does not always add work to the system. A change in the moles of gas entering or leaving the process is required.

Work will be added to a system, by increasing the pressure, if the number of gas moles entering the system is greater than the number of gas moles leaving the process. In the case where the number of gas moles leaving the system is greater than the gas moles entering, work will be recovered from the system. Where the gas moles entering and leaving the system are equal, changing the system pressure will have no effect on the flow of work within the system.

To elaborate further, if more gas moles enter a process than leave it, the work recovered from the turbine at the exit of the process is less than the work required by compressors at the entrance to the process thus the net effect is that the process is having work added to it. If more gas moles leave a process than enter it, the work recovered from the turbine at the process exit is greater than the work required at the compressors at the process entrance thus the net effect on the process is a work recovery. An example of a real process that works using a similar principle is a plasma gasifier. The work recovered from the turbine after the plasma is sufficient to supply the electricity to the electrodes and still have power left over. The number of gas moles leaving the plasma gasifier is greater than the gas moles entering it since the plasma combusts everything that enters it.

Finally there remains one last method of work addition/recovery for a process and that is the change of chemical potential. There are multiple ways of performing a change in chemical potential but, perhaps, the most common method is by the use of separation and mixing equipment.

Assuming ideal gases the enthalpy of mixing and separation can be considered to be zero. While the ideal zero enthalpy case is used in this paper it is possible to use non-zero separation enthalpy with the Graphical technique, if so desired.

The work of mixing and separation would then be given by Equation [7]:

$$\Delta G_{mix} = nRT \left(\sum_i x_i \ln x_i \right) \quad [7]$$

Where:

- n is the molar flow rate
- R is the universal gas constant
- T is the mixing Temperature
- x is the mole fraction of component i

Care should be taken to ensure that Equation [7] is assigned the appropriate sign to indicate the direction of work flow. In this case, a positive value indicates work addition which indicates a separation. A negative sign would be assigned to a mixing process.

The flows of heat and work have been defined. Heat, which inevitably comes from reaction, can also carry work with it by virtue of its temperature. Work can also be added or recovered by use of pressure changes and with mixing and separation.

While the simplified ideal gas case has been considered for this paper, any method for calculating Enthalpy and Gibbs free energy can be used. As long as Enthalpy and Gibbs free energy can be defined for a unit process it can be used with the Graphical technique that will be described in the rest of this paper.

4.2.3 Graphical Representation of Heat and Work

There are three unit processes that form the basis of the flow sheet synthesis of this paper: reaction, compression/expansion, separation/mixing.

The values of Enthalpy and Gibbs free energy calculated in the previous section, for these three unit processes, can all be drawn on to a plot of ΔH and ΔG , this plot will be referred to as the GH-space. Any unit process that has its Enthalpy and Gibbs free energy calculated can be represented by a point on the GH-space.

The position of a unit process within the GH-space has various implications that are described in great detail in other research.¹⁹

Similar work was carried out,²⁰ where a plot of Enthalpy and Entropy was used instead. Such a plot would provide a very sensitive measure of process reversibility. The problem in such a plot lies in that entropy is an abstract quantity that is not easily measured or related to physical reality, whereas Gibbs free energy is directly related to work.

Consider a reaction as a simple process. Any reaction can have its ΔH and ΔG calculated by using Equations [1] and [2] and drawn onto the GH-space, Figure 4.9:

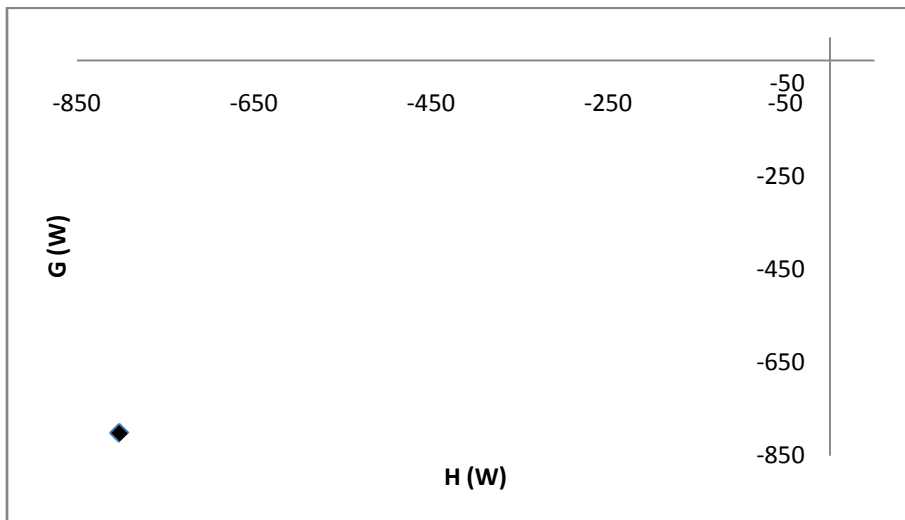
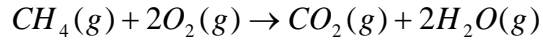

Figure 4.9: Combustion reaction as a point on the GH-space

The point in Figure 4.9 represents an exothermic work producing reaction, in this case the point is specifically the combustion of methane in oxygen:



By applying Equations [1] and [2] to the combustion reaction above the point in Figure 4.9 is drawn.

The reaction point represents the combustion reaction proceeding to completion. In other words, 1 mole of methane reacts with 2 moles of oxygen and proceeds to completion producing 1 mole of carbon dioxide and 2 moles of water.

However, what happens if either (or both) of the reactants is limited in some way? For instance, if only half as much methane or oxygen was supplied for the reaction? The answer is an obvious one. The combustion reaction would only release half as much heat and work.

This limit on the amount of reaction that can occur is referred to, in this paper, as “extent of reaction” which has been assigned the symbol “e”. The extent of reaction is the fraction, or percentage, to which a reaction proceeds. In this paper it is used as a scalar multiplier for the material balance that allows the length of a reaction vector to be manipulated.

Equations [1] and [2] can be applied to a reaction repeatedly for different supplies of reactants. The case of 100%, 50% and 20% are shown in Figure 4.10.

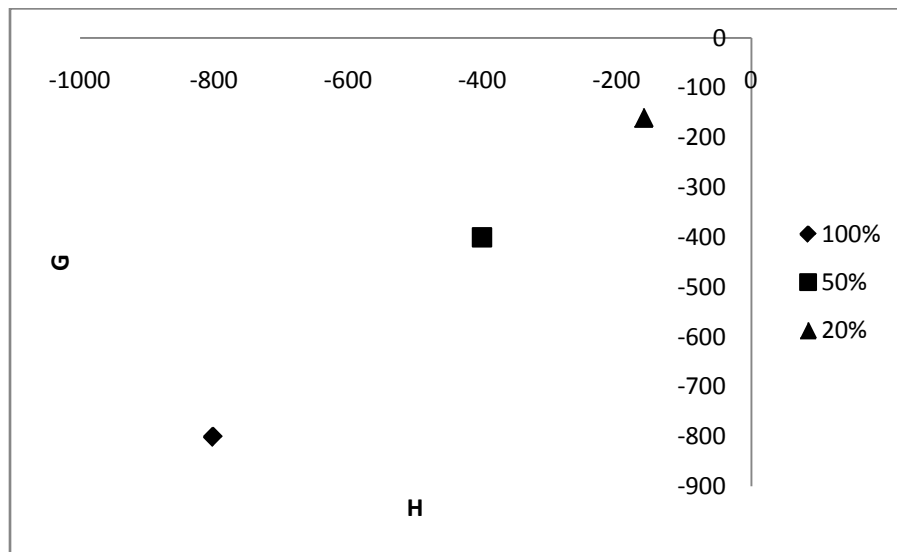
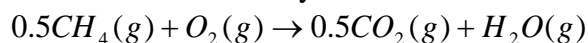

Figure 4.10: The effect of extent of reaction on heat and work

The “100%” point in Figure 4.10 is the same point from Figure 4.9. It represents the combustion reaction as written above.

The 50% point represents the same combustion reaction but with one (or both) of the reactants limited by half, similarly for the 20% point. It would be possible to rewrite the combustion reaction of each case by:



For the 50% case and for the 20% case:

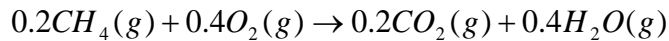

It would also be possible to use fractions of over 100% if the supply of reactants were more than for the 100% case. In other words the extent of reaction can be considered to be a basis of calculation. The three extents used in Figure 4.10 are all relative to the first combustion reaction.

It becomes clear that it would be possible to apply Equations [1] and [2] to a reaction for all possible values of extent of reaction. The trend is already visible in Figure 4.10, all the possible extents of reaction will create a straight line, Figure 4.11:

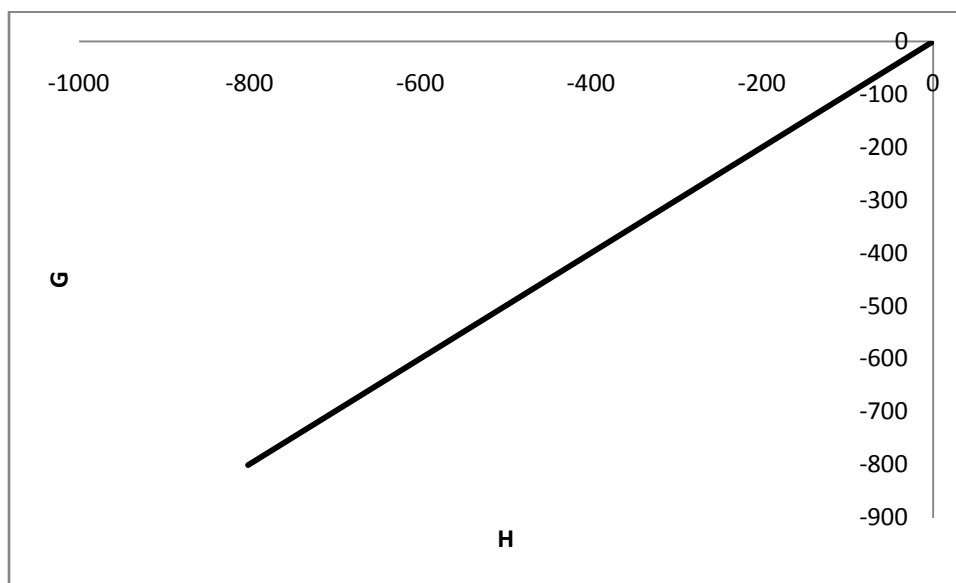

Figure 4.11: The set of all combustion extents with $0 \leq \epsilon \leq 1$

Figure 4.11 shows that reactions are now represented as lines on the GH-space.

Currently this shows the flow of heat and work provided by the combustion reaction. In this case all the work of the reaction is flowing with the heat. Recall that all the work can flow with the heat at only one temperature, the Carnot Temperature.

This means that *the application of Equations [1] and [2] to a reaction will represent that reaction operating at its Carnot Temperature only.*

This may be fine, even desirable, in some cases. Unfortunately this would be rare. Using the values of ΔH and ΔG , calculated from Equations [1] and [2], for the methane combustion reaction and using them in Equation [4] it can be found that the Carnot Temperature of the combustion reaction is around 14500K.

This temperature is clearly unworkable; another temperature needs to be used. In this case ΔH can still be calculated by Equation [1], since isothermal reaction and enthalpy being a weak function of temperature has been assumed. Rather than using Equation [2] to calculate the ΔG (which is only applicable at the Carnot Temperature), Equation [4] can be used to calculate the ΔG at any temperature.

Notice that Equation [4] has the structure of the equation for a straight line that goes through the origin and Figure 4.11 shows that reactions are straight lines on the GH-space. All this implies that the slope, or direction, of the straight line of a reaction will be affected by the temperature of the reaction.

This is shown in Figure 4.12 for two different temperatures on the methane combustion reaction.

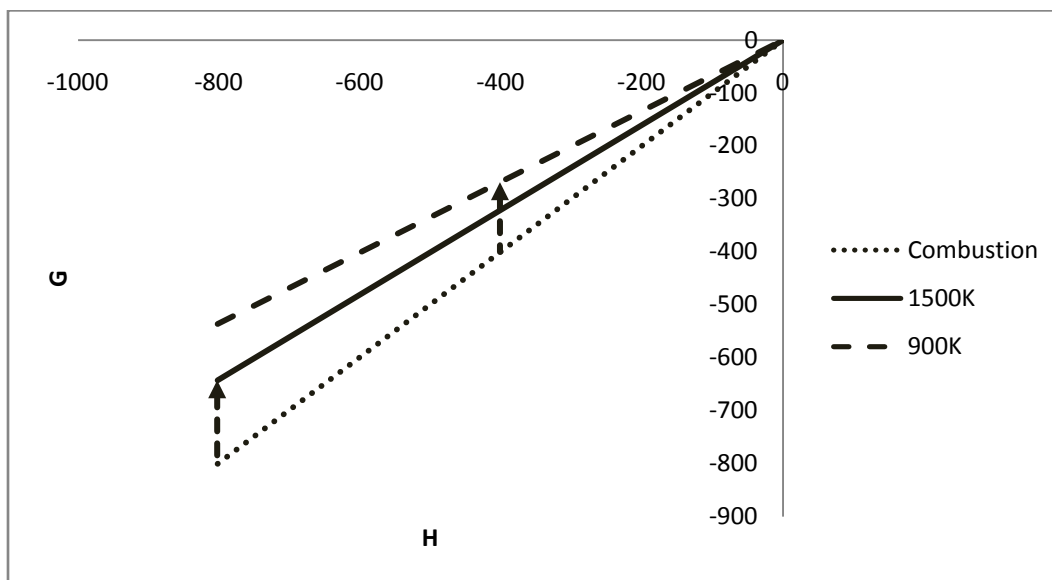

Figure 4.12: Effect of temperature on the Combustion reaction in the GH-space showing the decrease of available work with decreasing temperature

Figure 4.12 shows the Combustion reaction, at its Carnot Temperature (14500K), as the dotted line. The solid line shows the Combustion reaction at 1500K and the dashed line shows combustion at 900K. The reaction line has shifted upwards, at constant enthalpy, along the dashed arrows as a result of the new ΔG calculated at 1500K and 900K using Equation [4].

Figure 4.12 implies that by running a reaction at a lower temperature decreases the amount of work that can be recovered from the reaction while running at higher temperatures increases the amount of work that can be recovered. This is the case for an exothermic reaction, as is the case of the combustion in Figure 4.12. In the case of endothermic processes, running at higher temperatures increases the required minimum work input and running lower decreases the work requirement.

It is now been shown that reactions have a length defined by the extent of reaction and a direction defined by the temperature. It should be becoming clear that reactions, and in fact any unit process, can be represented on the GH-space as a vector.

There is one more thing that would prove useful in showing that all unit process are vectors on the GH-space: that unit processes can be added as vectors.

To show this it would be necessary to consider a slightly more complex case. A second unit process is needed. Let this second unit process be another reaction.

Consider the case of producing steam from liquid water. This could be written as:

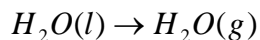

Equations [1] and [2] (or [4], if necessary) can be applied to this phase change to calculate the ΔH and ΔG , which can then be plotted into the GH-space, Figure 4.13.

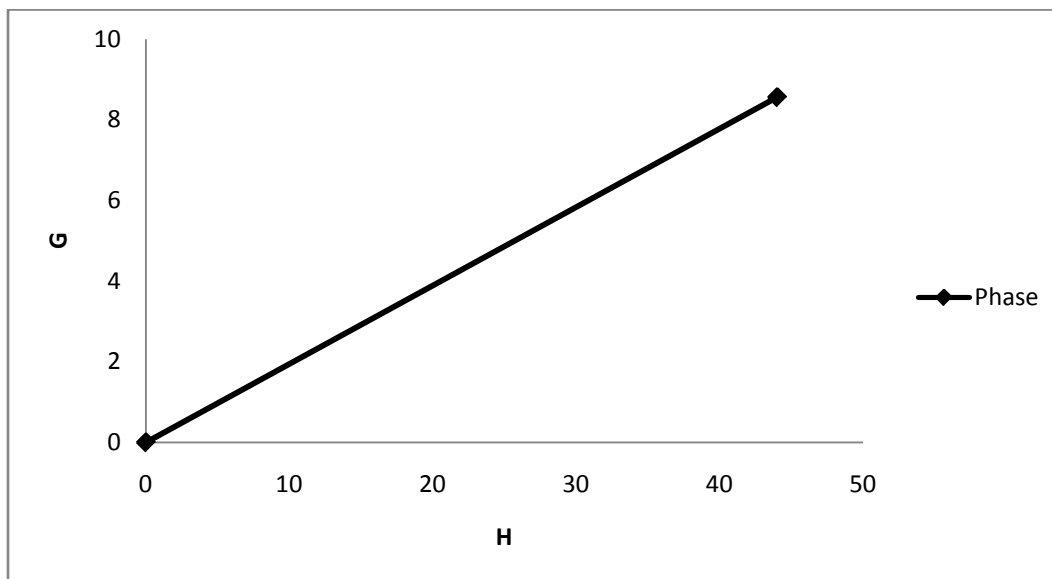
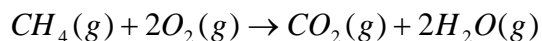

Figure 4.13: Phase change represented on the GH-space as a line for $0 \leq e \leq 1$ at its Carnot temperature and atmospheric pressure

Figure 4.13 shows the phase change of liquid water into steam at all possible extents between 0 and 1. As expected this is an endothermic reaction that requires the addition of both heat and work.

This heat and work needs to come from somewhere. One possible source would be the methane combustion reaction that has already been considered:



The ΔH and ΔG for the combustion reaction can also be drawn onto the GH-space, Figure 4.14:

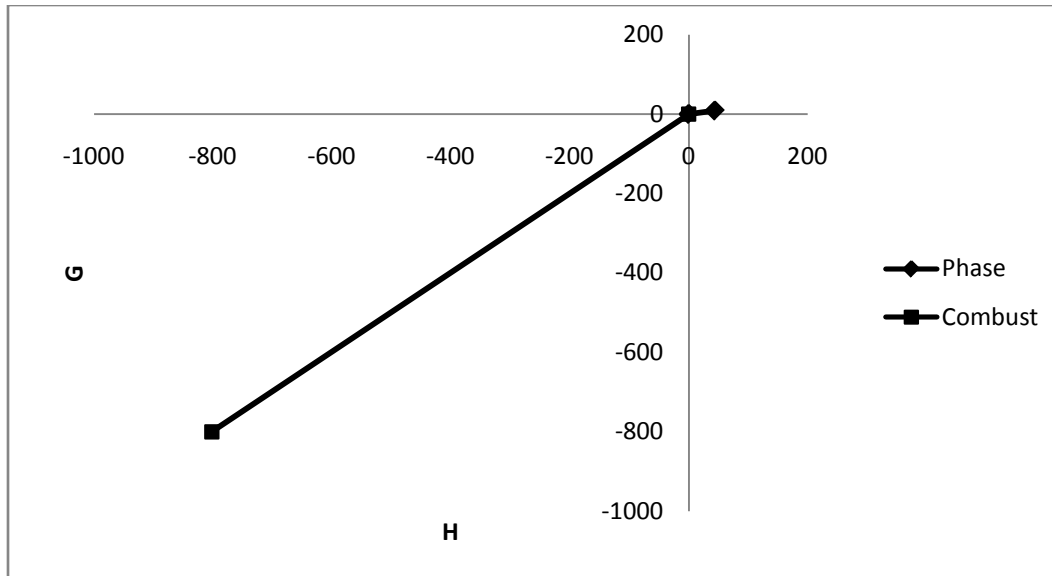

Figure 4.14: Phase Change and Combustion together on the GH-space for $0 \leq e \leq 1$

It is very clear from Figure 4.14 that the combustion provides a great deal more heat and work than the phase change actually needs. However, it has been shown that the length of the combustion line is dependent on the extent of the reaction. If less combustion was performed there would not be as much excess.

However, the idea of using the heat and work rejected from one unit to run another unit that requires heat and work is completely logical. The result of this is that *unit processes on the GH-space can be considered as vectors*. For this example of two reactive processes, they could be represented as:

$$e_{\text{combust}} \begin{pmatrix} \Delta H_{\text{combust}} \\ \Delta G_{\text{combust}} \end{pmatrix} \quad e_{\text{phase}} \begin{pmatrix} \Delta H_{\text{phase}} \\ \Delta G_{\text{phase}} \end{pmatrix}$$

The vector addition of these two reaction vectors can be represented by the resultant \vec{R} :

$$\vec{R} = \begin{pmatrix} \Delta H_{\text{process}} \\ \Delta G_{\text{process}} \end{pmatrix} = e_{\text{combust}} \begin{pmatrix} \Delta H_{\text{combust}} \\ \Delta G_{\text{combust}} \end{pmatrix} + e_{\text{phase}} \begin{pmatrix} \Delta H_{\text{phase}} \\ \Delta G_{\text{phase}} \end{pmatrix} = \begin{pmatrix} e_{\text{combust}} \Delta H_{\text{combust}} + e_{\text{phase}} \Delta H_{\text{phase}} \\ e_{\text{combust}} \Delta G_{\text{combust}} + e_{\text{phase}} \Delta G_{\text{phase}} \end{pmatrix}$$

To determine the extent of combustion required to change the phase of 1 mole of water the resultant could be written as:

$$\vec{R} = \begin{pmatrix} \Delta H_{\text{process}} \\ \Delta G_{\text{process}} \end{pmatrix} = e_{\text{combust}} \begin{pmatrix} \Delta H_{\text{combust}} \\ \Delta G_{\text{combust}} \end{pmatrix} + \begin{pmatrix} \Delta H_{\text{phase}} \\ \Delta G_{\text{phase}} \end{pmatrix}$$

As explained with Figure 4.14 combustion provides a great deal more heat and work than necessary; the best thing to do would be to burn just enough methane to provide all the heat for the phase change. This means choosing e_{combust} such that the enthalpy of the process is zero:

$$\vec{R} = \begin{pmatrix} 0 \\ \Delta G_{process} \end{pmatrix} = 0.0549 \begin{pmatrix} \Delta H_{combust} \\ \Delta G_{combust} \end{pmatrix} + \begin{pmatrix} \Delta H_{phase} \\ \Delta G_{phase} \end{pmatrix}$$

Doing so results in Figure 4.15:

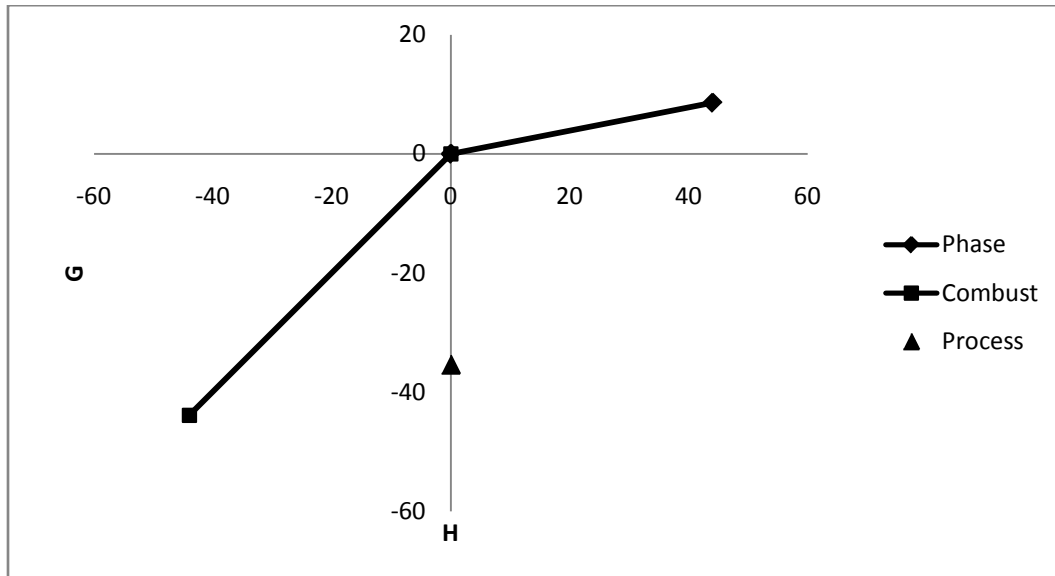

Figure 4.15: Combustion extent modified to produce just enough heat for an adiabatic resultant process but with excess work

In Figure 4.15, the extent of the combustion has been decreased so it provides just enough heat to turn the liquid water into steam. The point labeled “process” is the vector addition of the two separate reaction vectors.

As can be seen, the process as a whole provides just enough heat as intended but it also provides too much work, evidenced by the negative ΔG .

It would also be an option to change the extent of the combustion such that it provides just enough work for the phase change. This requires choosing the extent of the combustion reaction such that the work for the process is zero:

$$\vec{R} = \begin{pmatrix} \Delta H_{process} \\ 0 \end{pmatrix} = 0.0107 \begin{pmatrix} \Delta H_{combust} \\ \Delta G_{combust} \end{pmatrix} + \begin{pmatrix} \Delta H_{phase} \\ \Delta G_{phase} \end{pmatrix}$$

This situation is represented by Figure 4.16:

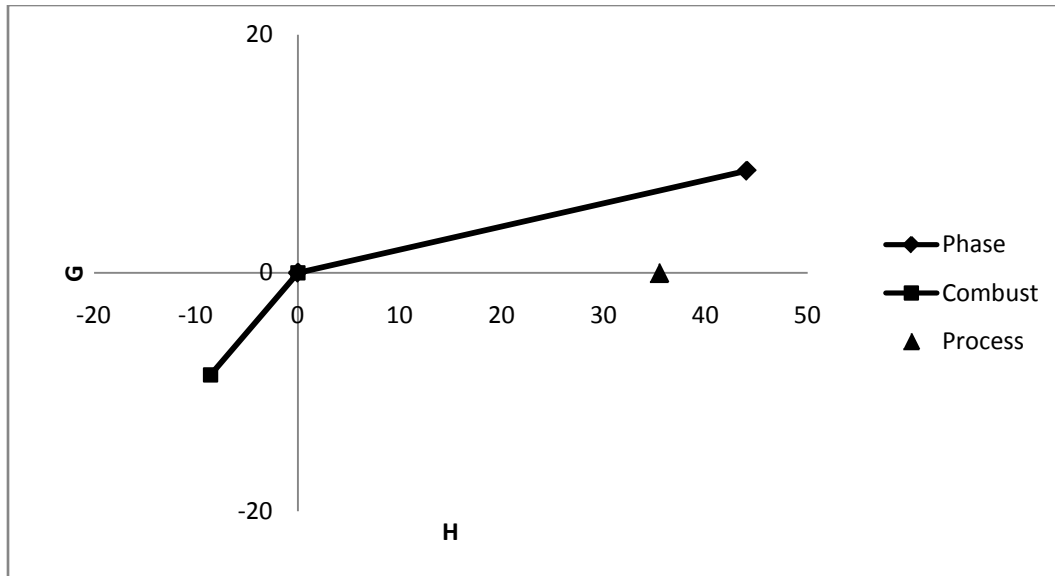

Figure 4.16: Combustion extent modified to produce just enough work in the resultant process but with a deficit in heat

Figure 4.16 is similar to Figure 4.15 except that this time the process has no work excess. There is just enough work being provided for the steam production.

The problem with this process is that there is still a heat deficit, evidenced by the positive ΔH . If that deficit is not made up the process cannot proceed. Since all the heat and work supply is coming from only one source (combustion) the extent of that combustion needs to be increased to provide the necessary heat. This would require the extent (and therefore length) of the combustion reaction to be increased; eventually reaching the adiabatic excess work solution of Figure 4.15.

For the case of the combustion and steam generation process, the overall process is limited by heat. In other words, providing the required heat will always result in an excess work.

Processes can be limited by either heat (where $\Delta H=0$) or work (where $\Delta G=0$). Which one is limiting depends upon what unit processes are being used within the process. Generally speaking; *the process, as a whole, must be have either excess heat or excess work or both must be zero*. The implication for the GH-space is that the overall process must be within the 3rd quadrant, preferably on one of the axes or ideally at the origin.

This means that, for the current example, the preferred operating point would be the “process” point shown in Figure 4.15, adiabatic with excess work.

Choosing Figure 4.15 as the operating point for the steam formation example does three things:

Firstly, it sets the energy balance for the process. The process *will be overall adiabatic*. Secondly, it sets the work balance for the process. The process *will have an overall excess of work*. Finally, it **sets the overall material balance** of the process since it sets the values for the extents of reaction.

The process balance could be summarized as:

Material balance	ΔH (W)	ΔG (W)
$\text{H}_2\text{O} + 0.055\text{CH}_4 + 0.11\text{O}_2 \rightarrow 1.11\text{H}_2\text{O} + 0.055\text{CO}_2$	0	-35.36

This material balance may be for an extremely small process but at this level of detail the size of the mass, heat and work flows can easily be scaled to any desired value.

This is one of the most interesting results of the graphical technique. The three balances of the process are already known, **without any flow sheet existing**. Normally mass, energy and work balances are done on a flow sheet, once the process layout has already been finalized. This technique allows the *balances to be used to determine what the flow sheet should be*.

The question now is how Figure 4.15 is used to formulate a flow sheet? The example of steam generation is a simple case. The material balance for the overall process and each unit in the process is related directly to the extent of reaction for each unit, which were chosen to give the overall adiabatic excess work process.

From Figure 4.15 the flow sheet might look like Figure 4.17:

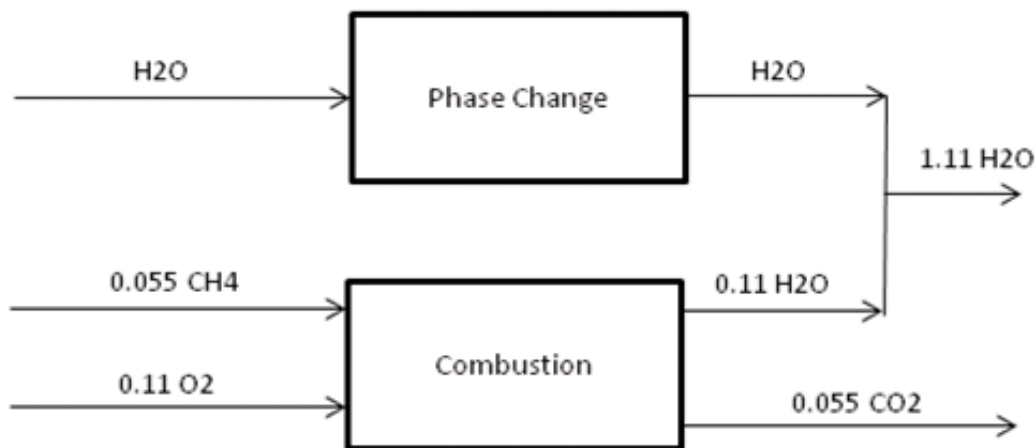

Figure 4.17: Mass-Flow of adiabatic steam generation using Figure 15

Figure 4.17 is a simple layout for a possible adiabatic steam generation process. The material balance comes from the extents of reaction used in Figure 4.15 to provide the correct amount of heat for the process.

The overall process was overall adiabatic and work producing but the individual units of the process is not, the flows of heat and work in Figure 4.17 can be drawn as in Figure 4.18:

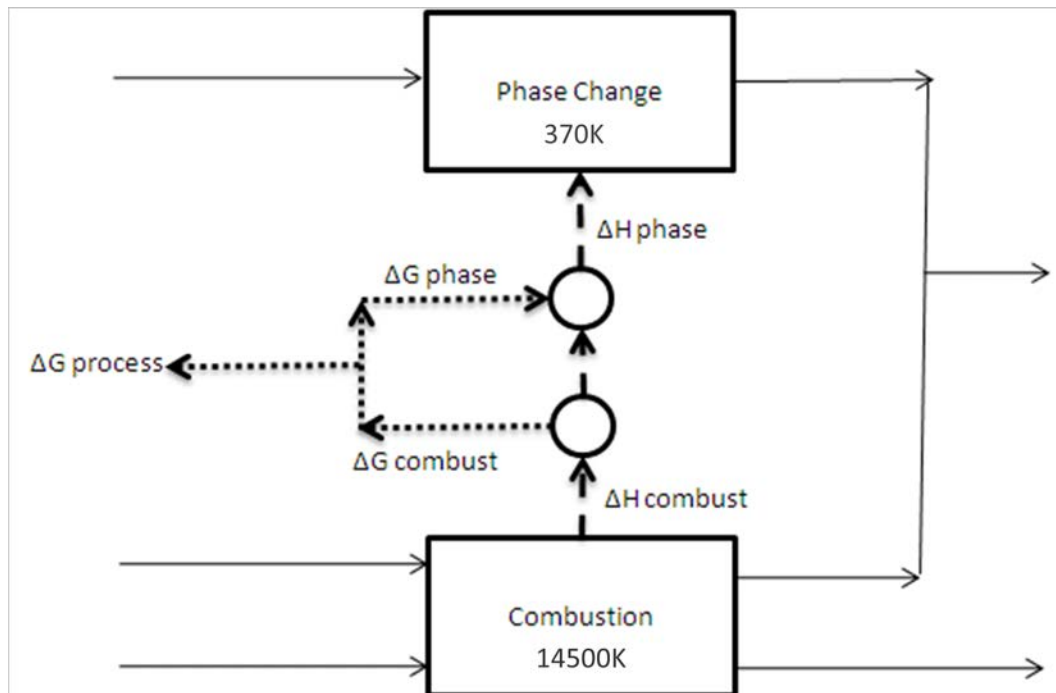

Figure 4.18: Heat and Work flow for steam generation process where the circular units represent Carnot engines

Figure 4.18 shows the flows of heat as dashed lines and the flows of work as dotted lines. The overall process is adiabatic as expected. The excess work produced from the process is the excess work produced by the combustion reaction in providing the sufficient heat.

Figure 4.18 shows the heat and work flowing through other units that may be interpreted as “heat engines”. The intention is to show that the *work is flowing with the heat*. Conceptually, this is easiest to show with a heat engine.

The next point worth noting is that the temperature of each of the individual units is currently the Carnot temperature of each unit. The Carnot temperature for the phase change reaction is 370K. This is the boiling point of water at 1 atmosphere pressure. It has already been established that the Carnot temperature for the combustion reaction is unworkably high at 14500K. This extremely high temperature is largely responsible for the excess work being produced by the process. The effect of modifying the combustion temperature to something more reasonable is that there is less excess work within the process and thus less work can be potentially recovered from the process. Combustion at 1000K would be a more typical example of temperature to use.

Recall that the direction of the reaction vectors is dependent on the temperature of the reaction. It should be noted that it has been assumed throughout the paper that the ΔH is not affected by temperature. This means that, for a heat limited process, any changes in temperature will not have any effect on the overall mass or energy balances of the process. Only the work balance will be affected by temperature modifications. The situation of a work limited process is somewhat more complex as changes in temperature can have an effect on all three balances, although this effect tends to be small.

Returning to the steam generation example, we keep the temperature of the phase change unit at 370K. It is sufficient for the purposes of this example to produce steam at 1 atmosphere. Rather than use the impossible Carnot Temperature for combustion, we use 1000K instead by using Equation [1] for ΔH and Equation [4] for ΔG . Figure 4.19 can then be drawn:

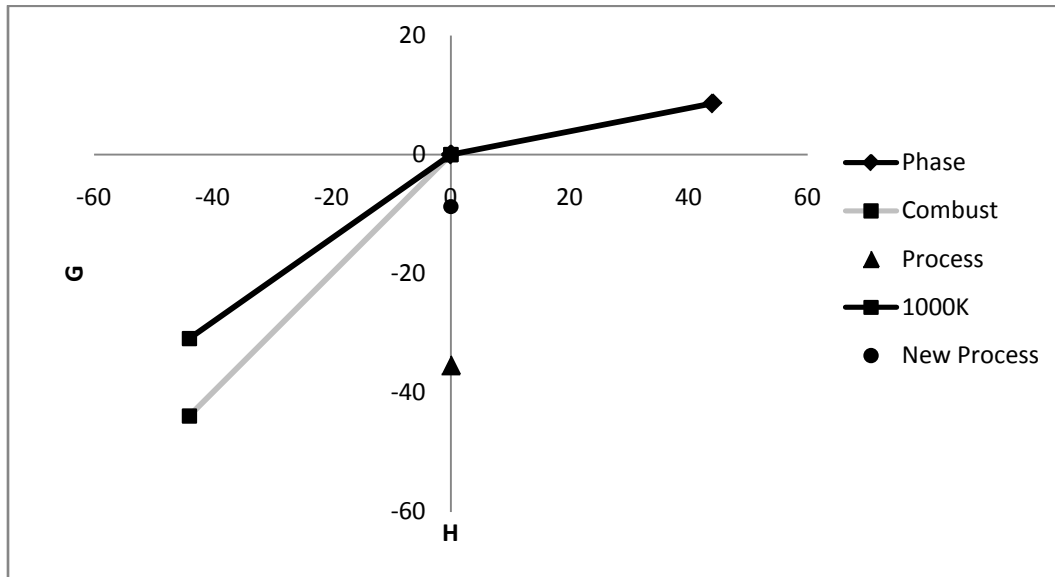

Figure 4.19: Modification of combustion temperature to 1000K, showing decrease in available work due to departure from combustion Carnot temperature

Figure 4.19 is a reproduction of Figure 4.15 with the modified conditions added in. The lighter line of combustion shows combustion at its Carnot temperature and the darker line shows how the combustion reaction vector moved due to the change in temperature.

The point for the overall process (represented by the triangle) has also moved up (to the point represented by the circle), this implies that decreasing the temperature of the combustion has had the effect of decreasing the excess work available from the process. It may even be possible to reduce the excess work of the process to zero by decreasing the combustion temperature even further. Logically, this would happen when the combustion temperature is equal to the phase change temperature.

Alternatively, a similar approach could be used on the Phase Change reaction instead. By conducting the steam generation at a higher temperature the excess work could also be decreased, reaching zero when the phase change and combustion temperatures are equal.

Changing the temperatures in the process does not have the effect of making the process more reversible. The effect of departing from the Carnot temperature is decreasing the amount of useful work that can be *recovered* from the process. In this example, decreasing the combustion temperature decreases the amount of work being used from the combustion reaction. Increasing the temperature of the phase change increases the amount of work required from the combustion. On Figure 4.19, the work *between* the triangle point and the circle point is lost work potential.

Some lost work is almost always unavoidable. This is because of the combustion reaction with its impossible Carnot temperature. The GH-space does show a way of using as much of the available work as possible while making best possible use of the heat and mass flows. This is also where other considerations can begin to have an influence on the choice of temperature and on the use of the graphical technique.

Considerations such as chemical equilibrium or more practical concerns like how low a temperature can combustion be realistically performed or how high a temperature steam can be generated.

In still other cases having a manageable amount of excess work may actually be beneficial.

Consider that the combustion reaction is now left at 1000K and the steam generation is modified. A choice needs to be made at this point, what kind of steam is desired to be generated? This can be vary over a significant range, it depends what application the designer wishes to generate the steam for.

For purposes of heat transfer, high temperature saturated steam is normally desired due to the improved heat transfer coefficients of saturated steam. In power turbines, high pressure superheated steam is desired for the first stage.

For this example consider producing high temperature steam at 523K, let the combustion reaction proceed at 1000K. Drawing these conditions onto the GH-space gives Figure 4.20:

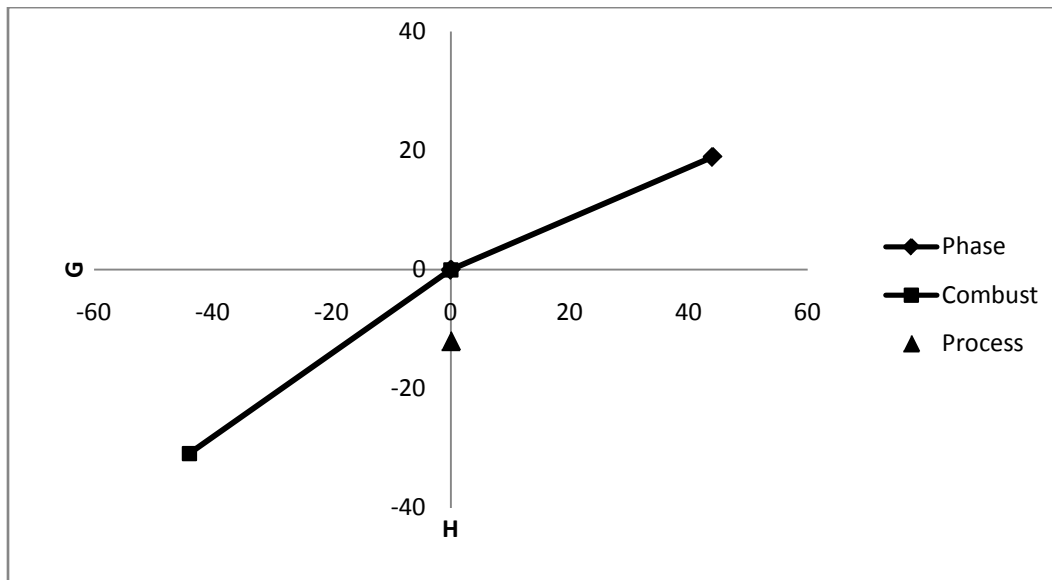

Figure 4.20: Steam generation at 250°C and Combustion at 730°C with vector addition to an overall adiabatic process with excess work to be recovered or rejected

Figure 4.20 now shows the process of Figure 4.17 producing steam at 523K while the combustion proceeds at 1000K.

Currently this occurs all at 1 atmosphere pressure. This would mean the steam is highly superheated. To make the steam saturated it would be necessary to increase the pressure of the process. The saturation pressure, in this case, is 39.2 atmospheres.

Looking at Figure 4.17 it can be seen that more moles of gas leave the process than enter it, since the water feed is liquid. This means that increasing the pressure of the process would result in some of the excess work being recovered, since the work used to increase the pressure of the feed is less than the work that would be recovered by decompressing the products through a turbine thus resulting in a net recovery of work as shaft work from the gas product turbine.

Compressing to the steam saturation pressure of 39.2 atmospheres in Equation [6] the amount of work recovered from the process can be calculated and drawn onto the GH-space, Figure 4.21:

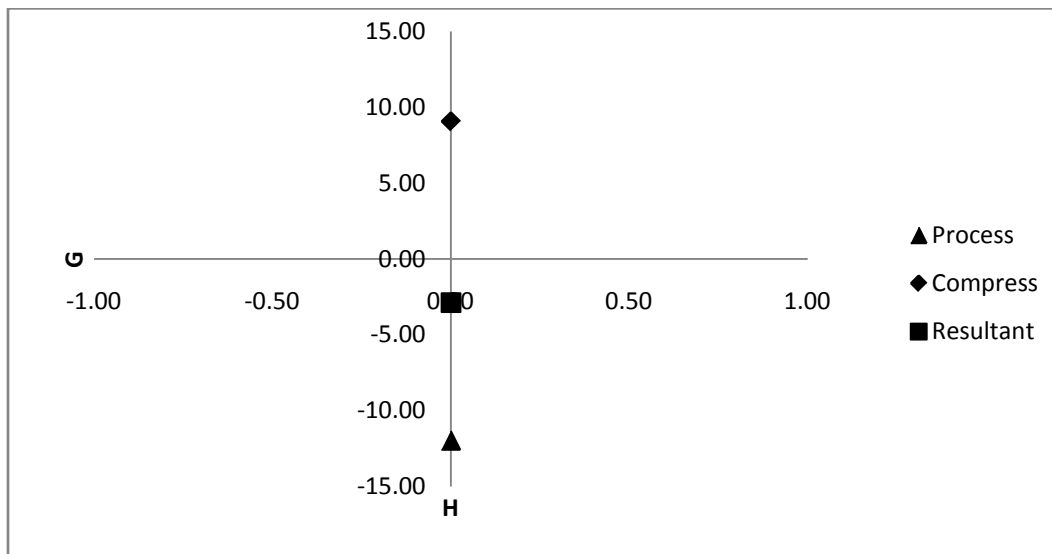

Figure 4.21: Steam Generation Process with Compression and work recovery. From the origin to the triangle is the potential work, from origin to diamond is work recovered by compression/turbine system, origin to square is the addition of the previous two vectors.

Figure 4.21 can be somewhat difficult to read. The point labeled “process” is the same process point of Figure 4.20. It is the resultant vector of the combustion and phase change.

The point labeled “compress” is the end point of the compression vector (from compressing the gas feeds, methane and oxygen, and decompressing the gas products, steam and carbon dioxide, through a turbine) beginning at the origin and ending at the net work recovered from 39.2 atmospheres. From Equation [6] it may come as a surprise to see this vector in a positive direction, great care must be taken with the direction of work recovery vectors. In this case the “compress” vector is pointing in the positive direction since it represents a recovery of some of the excess work of the “process” point. Thus the work recovery vector must have the opposite sign of the “process” point. Finally the “resultant” point represents the vector addition of “process” and “compress”.

Note that there is still excess work for the entire process, since the resultant of the “process” and “compress” vectors does not reach the origin of the GH-space. The pressure required to recover all the excess work (can get to the origin of the GH-space) can be calculated. In this case it would require over 120 atmospheres, which would mean the liquid water would not become steam. This means that there is a certain price to pay in lost work for this example process. You cannot recover all the excess work but it is possible to at least try recovering some of it, in this example 75% of the excess is recovered.

Separation systems still remained to be defined within the GH-space. Separation and mixing appear much the same as for compression. However, separation acts to undo the work of mixing in the reactors. In the case of complete separations the net work effect on the entire process would be zero since the separation will exactly undo the work of mixing in the reaction. When the separations are not complete or perfect the work of mixing will always be greater than the work of separation, the net effect will actually be to increase the amount of work that must be recovered from the process by other means, like additional compression.

Using the above information it would be possible to redraw the flow sheet as Figure 4.22:

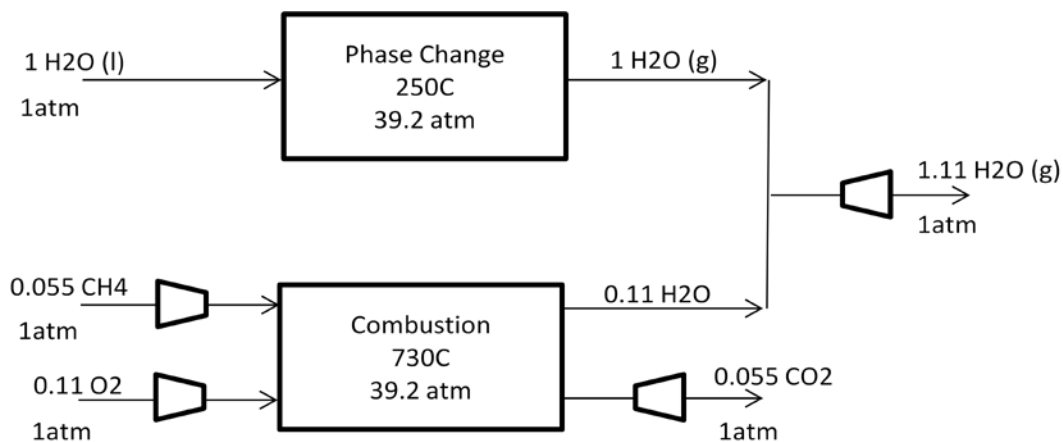

Figure 4.22: Mass flow and compression for steam generation with turbine work recovery

The flow sheet of Figure 4.22 may not be a practical one. Some issues may not make sense, such as increasing the pressure for steam and then decreasing it again in a hypothetical turbine. What has actually ended up happening here is that this example process is no longer simply a steam generation process; it has evolved into a power and steam co-generation process.

The purpose of this example was to illustrate the method behind the graphical technique. The graphical technique allows important interactions between unit processes to be taken into account at the very earliest stages of design.

Although ideal cases are considered in this paper, the technique can allow for as much complexity as is desired. The primary requirement is that ΔH and ΔG can be calculated.

4.3 Development of a Fischer-Tropsch process flow sheet

4.3.1 Defining the independent material balances of the process

It has been established that there are three primary ideas behind the use of the GH-space: Mass, Heat and Work. A very simple example in forming steam has already been developed to introduce the concepts. It is now possible to use these three ideas in the more complex example of synthesizing a flow sheet for the more complex case of an FT-synthesis process.

The question is: how are the properties of Mass, Energy and Work used to synthesize what the flow sheet should be? This is opposed to using Mass, Energy and Work to analyze an existing flow sheet, which is typically the approach used.

The first step is to define the independent material balances for the process. These independent material balances are the chemical transformations that define the purpose of each process.

Every chemical process starts with a raw material. It has been established in previous work,² that natural gas is a preferable starting feedstock, if it is available. For this paper consider that one of the starting feed materials will be natural gas. Next assume that natural gas is pure methane.

The first step would be to transform the methane feed into synthesis gas. This would be done by methane steam reforming:

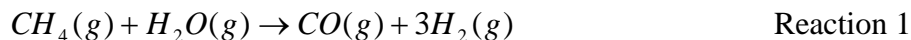

Equations [1] and [2] can be applied to steam methane reforming with the results shown in Table 1. This will show that methane reforming is an endothermic process that also requires an input of work. It is therefore necessary to define the next material balance as one that can supply heat and work.

The combustion of methane has already been shown to serve this purpose. Thus some of the methane feed can be combusted in oxygen to provide heat and work for the rest of the process:

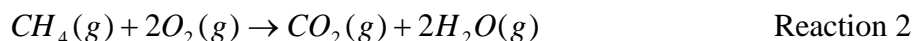

Once the synthesis gas has been produced it can then be used to produce the desired hydrocarbon products. The hydrocarbon chains formed by the FT reaction can have a vast variety of chain lengths. For this paper consider the hydrocarbon products to be the monomer of the chains, $-CH_2-$:

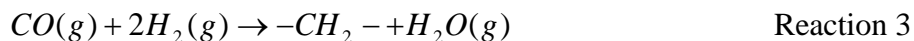

Application of Equations [1] and [2] to the FT reaction shows that it is an exothermic work producing process, see Table 4.1. It could be also be used, along with the combustion, to supply heat and work to the rest of the process.

Notice that Reaction 3 uses synthesis gas, mixture of Carbon Monoxide and Hydrogen, in a 1:2 ratio but Reaction 1 produces synthesis gas in a 1:3 ratio. The 1:2 ratio is the preferred ratio in most synthesis processes, such as the FT reaction considered here as well as methanol. A 1:3 ratio would be more desirable in other processes such as Ammonia.

Thus it is necessary to modify the ratio of the synthesis gas. This can be done using the Water-Gas Shift reaction:

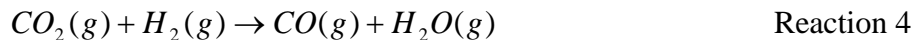

Also note that in the methane steam reforming step. Carbon Monoxide, Hydrogen and Water will all be present together. This means that there will be some Water-Gas Shift reaction accompanying methane steam reforming which will further modify the synthesis gas ratio before it reaches the hydrocarbon synthesis.

Finally it should be noted that all these individual material balances utilize or produce water in the form of steam. Water does not occur naturally in this form. It would therefore be necessary to consider the phase change of water:



Equations [1] and [2] can be applied to all five of these reactions. The summary of this is given in Table 4.1:

Table 4.1: The independent material balances with the energy and work balances

Reaction	Balance	H (W)	G (W)
Methane Reforming	$CH_4 + H_2O \rightarrow CO + 3H_2$	206.12	142.16
Combustion	$CH_4 + 2O_2 \rightarrow CO_2 + 2H_2O$	-802.35	-800.71
FT Synthesis	$CO + 2H_2 \rightarrow -CH_2 - H_2O$	-152.32	-83.07
Water-Gas Shift	$CO_2 + H_2 \rightarrow CO + H_2O$	41.19	28.59
Phase Change	$H_2O(l) \rightarrow H_2O(g)$	44.01	8.56

Each of these balances, as written, will form the basis of calculation. In other words, the balances in Table 4.1 will have an extent of reaction of 1 as written.

These five independent material balances will form the foundation for the rest of the flow sheet synthesis. There could well be other reactions possible in a real process. These five will be considered for this paper although the GH-space is capable of handling as many reactions and

systems as is desired. Additionally, in this synthesis, any other reactions will be linear combinations of the 5 independent material balances given in Table 4.1.

In defining the independent balances of a system there are a variety of different things that could be done; there is great room for innovation at this very first step of the synthesis. For instance, in methane steam reforming it has been established that this requires an input of heat and work. This could come from combustion as is the case in Table 4.1, it may also be possible to combust some of the excess hydrogen product instead. This would be a “cleaner” alternative to combusting fossil fuel. This does have implications later; in separating the needed hydrogen, providing the needed oxygen. It also turns out that more than the excess hydrogen is needed to provide sufficient heat and work, which has an undesirable effect on water-gas shift. So while that may not be a good idea in this case it shows that there are many possibilities before a flow sheet even exists.

4.3.2 Drawing the independent balances into the GH-space

Using the data in Table 4.1, the five balances can be drawn into the GH-space as shown in Figure 4.23:

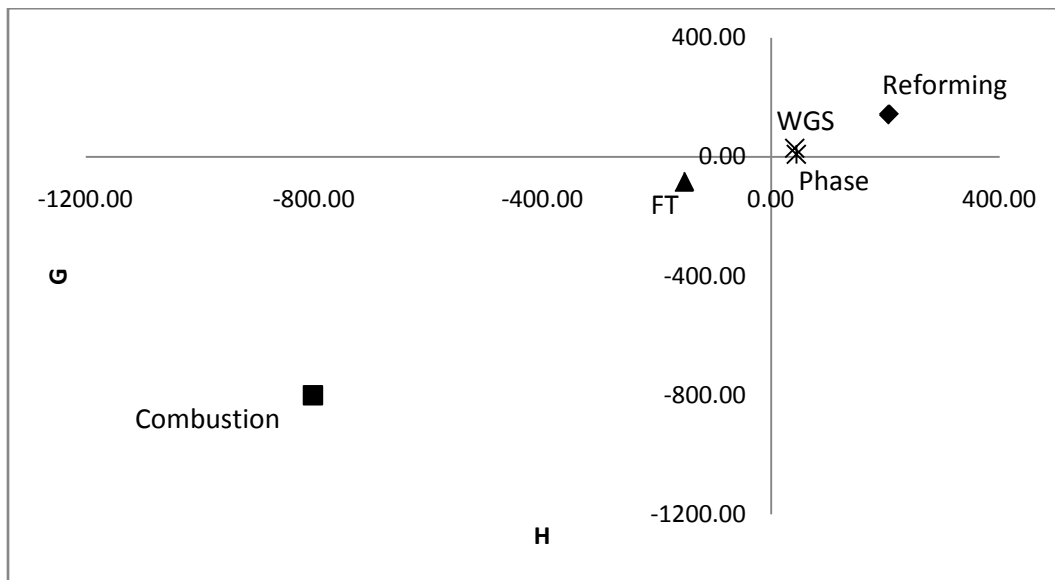

Figure 4.23: The 5 material balances drawn onto the GH-space with $e=1$

Recall from Figure 4.15 that all possible combinations of two reactions were on the dotted line connecting the two vectors. In Figure 4.23 there are more than two reactions, so there is no longer a dotted line to represent all the possible combinations of the reactions but there is now a region to represent all these combinations. By inspecting Figure 4.23 it is clear that, due to where the individual balances lie, this region would be very difficult to see when drawn to the scale of Figure 4.23.

It would be useful to attempt to draw the region. To do this, the positions of each of the balances will be exaggerated on the GH-space and the region of all possible balance combinations will be represented on Figure 4.24:

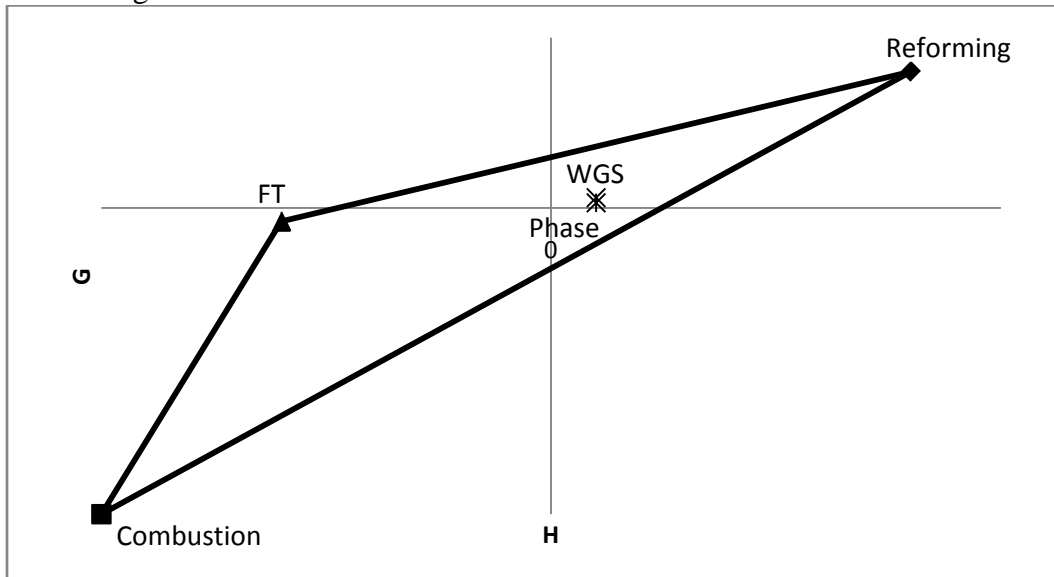

Figure 4.24: The 5 balances with exaggerated positions to show a possible operating region for any combination of the independent material balances

Figure 4.24 is drawn completely out of scale. The purpose of Figure 4.24 is to show there is a triangular region, bounded by the outermost reactions. Many of the possible combinations of the 5 material balances must lie within this triangular region, the overall material balance for all the possible flow sheets with those five reactions will exist inside the triangular region. The orientation of this triangle in the GH-space is effected by the temperatures of each reaction. In the case of the region for Figure 4.23 (exaggerated in Figure 4.24) the region applies to the Carnot temperatures for each reaction.

The most significant results of Figure 4.24 is that any number of process units can all be represented on a single set of 2-dimensional axes and this same set of 2-dimensional axes allows the mass, energy and work balances to be solved together simultaneously.

Figure 4.24 shows that there is a region of possible operating points possible for the example FT process. A process can only operate at a single point. The question now becomes: What point in the region is the best to choose?

It has been established that synthesis gas needs to be produced in a 1:2 ratio of Carbon Monoxide to Hydrogen and that Steam reforming produces synthesis gas in 1:3 ratio. Writing the material balance for a 1:2 ratio:

$$2(CO) = (H_2)$$

Since both the Carbon Monoxide and Hydrogen are produced by the Steam Reforming and Water-Gas Shift reactions, the above material balances can then be written in terms of those extents of reaction since this material balance only concerns the units producing syngas:

$$2(e_1 + e_4) = (3e_1 - e_4)$$

$$e_4 = \frac{1}{3}e_1$$

The implication of the above material balance is that the extent of the Water-Gas shift reaction must always be 1/3 the extent of the methane steam reforming reaction to produce a 1:2 mixture of synthesis gas.

Additionally the maximum possible extent for the FT synthesis, Reaction 3, can be calculated as follows, when all of the Carbon Monoxide is converted to liquid product:

$$(-CH_2-) = (CO)$$

$$e_3 = e_1 + e_4$$

In other words, the maximum extent possible for the FT synthesis reaction is equal to the amount of Carbon Monoxide (or half the Hydrogen, alternatively) formed by Steam Reforming (Reaction 1) and Water-Gas Shift (Reaction 4)

With these constraints on the possible extents of the reactions, the operating region of Figure 4.24 collapses into an operating line, shown in Figure 4.25, once again using the exaggerated points for illustration:

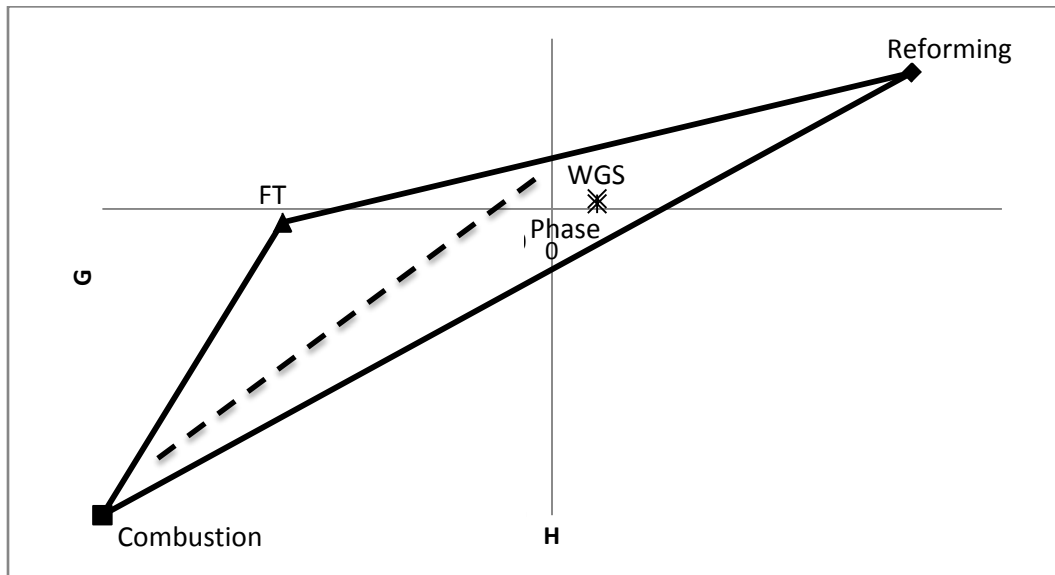

Figure 4.25: Operating Region collapsed to an operating line with constraints on extent, producing the preferred ratio of H₂:CO

With the constraints on the extents of the Water-Gas Shift and FT synthesis all the possible operating points for a process must lie on the dashed line in Figure 4.25. The choice of operating point for the FT process has gone from an entire region to a single line; a single operating point however is still needed.

Consider the “operating line” of Figure 4.25. It is now possible to draw this line to the correct scale, Figure 4.26, and allow further investigation towards the choice of a single point:

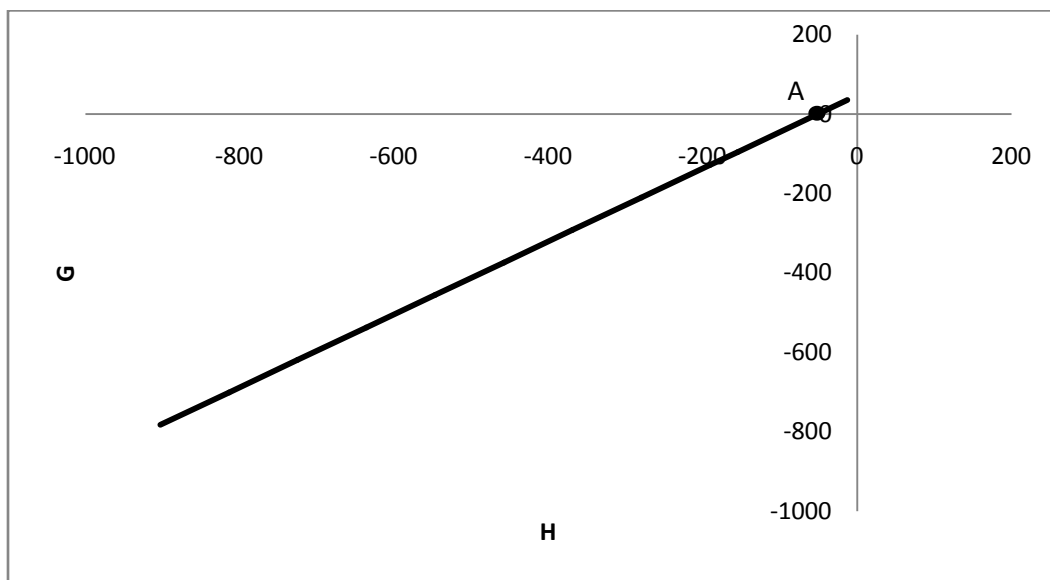

Figure 4.26: Process operating line after inclusion of material balance constraints, with preferred $H_2:CO = 2:1$

All the possible processes that combine the five reactions in such a manner as to conform to the material balance constraints must lie on the operating line of Figure 4.26. Which operating *point* to choose for the flow sheet development now depends upon the judgment of the individual designer.

For instance, consider the point A on Figure 4.26. At point A the overall process will be overall exothermic but have no excess work. In other words, the excess heat represents heat at ambient temperature. It is heat that does not carry any ability to perform work. The subtle implication of point A is that the overall process is limited by work (as opposed to heat limited) which means that the overall process will always have excess heat. This does not mean there are no work flows in the process. It means that the process could be fully work integrated.

Point A also represents a process that provides just enough work for all the units. Further to the discussion of Section 4.2.3 this would probably be the best operating point to choose for the overall process. It will be the point used in the rest of the flow sheet synthesis in this paper but first consider choosing an operating point, on the operating line, that is not point A.

Choosing to operate above point A would imply a process that has more than sufficient heat for the process but not enough work. It has been discussed that this work deficiency could be made up using three methods. Using heat would require additional combustion, the combustion

reaction does not have a constraint which would mean the operating point would then move down towards the point A. Separations act to undo the work of mixing and can therefore never be used to add excess work to a process. Compression could be a means to add the excess work since more gas moles would be entering the overall process than leaving it. The restricting factor would then be on what pressure is required. However, operating above the point A using a pressurized system would be possible.

Alternatively an operating point below point A could be used. This implies that heat and work would need to be removed from the overall process. Failing to do so would result in irreversibility. Operating the whole process at pressure to recover the work is not an option due to it being a method to add work rather than recover it. However, running *some* of the process sections at pressure could result in work recovery. For instance, operating the Reforming reaction and Water-gas shift reaction at pressure with the others at atmospheric pressure would allow us to recover work from the process. Once again the limiting factor would be the necessary pressure to recover this excess work. This means that operating below point A on the operating line could also be done.

It appears that choosing point A would still be the most sensible choice since the operating pressure at point A would be the least limiting of all the possible choices and would thus allow for more flexibility as the synthesis begins to increase in complexity.

It should also be noted that the operating line of Figure 4.26 applies to the five process reactions operating at their Carnot temperatures. Changes in the reaction temperatures cause the operating line to move upwards or downwards on the GH-space as well as some effect on the slope of the operating line. However, the process will always be limited by work and the discussion above will remain unchanged.

The important result from Figure 4.26 is that, regardless of any modifications or choices made, the resultant vector for the overall process must have no excess work and some excess heat. Mathematically this could be represented by:

$$e_{\text{reform}} \begin{pmatrix} \Delta H_{\text{reform}} \\ \Delta G_{\text{reform}} \end{pmatrix} + e_{\text{combust}} \begin{pmatrix} \Delta H_{\text{combust}} \\ \Delta G_{\text{combust}} \end{pmatrix} + e_{\text{WGS}} \begin{pmatrix} \Delta H_{\text{WGS}} \\ \Delta G_{\text{WGS}} \end{pmatrix} + e_{\text{FT}} \begin{pmatrix} \Delta H_{\text{FT}} \\ \Delta G_{\text{FT}} \end{pmatrix} + e_{\text{phase}} \begin{pmatrix} \Delta H_{\text{phase}} \\ \Delta G_{\text{phase}} \end{pmatrix} = \begin{pmatrix} -\Delta H_{\text{process}} \\ 0 \end{pmatrix}$$

4.3.3 The overall Material balance

Currently there appears to be ten degrees of freedom for the flow sheet synthesis: Each of the individual extents of reaction and each individual temperature. This is before pressure or separation is even considered. It is a very large number of variables that could make any kind of analysis extremely complex.

To cut down on the number of degrees of freedom, performing an overall material balance using each independent material balance could be done.

How this could actually be done is a matter of personal preference but one method will be presented to show the type of thinking used.

Firstly, consider the extent of the reforming reaction to be always equal to 1. In other words:

$$e_{\text{reform}} = 1$$

This essentially eliminates the extent of the reforming reaction as a degree of freedom.

Next consider the extent of the combustion reaction, e_{combust} , to be left as a degree of freedom.

It was shown in section 3.1 that the extent of the WGS reaction must be 1/3 the extent of the reforming reaction in order to produce Hydrogen and Carbon Monoxide in a 2:1 ration:

$$e_{\text{WGS}} = \frac{1}{3} e_{\text{reform}} = \frac{1}{3}$$

It was also shown in section 3.1 that the extent of the FT reaction depends on the amount of Carbon Monoxide produced in Reforming and WGS:

$$e_{\text{FT}} = e_{\text{reform}} + e_{\text{WGS}} = 1 + \frac{1}{3} = \frac{4}{3}$$

Finally the extent of the phase change reaction can be calculated by a steam material balance between all the reactions which allows us to determine whether steam is needed or produced by the process:

Steam In + Steam Produced = Steam Consumed

$$e_{\text{phase}} + 2e_{\text{combust}} + e_{\text{WGS}} + e_{\text{FT}} = e_{\text{reform}}$$

$$e_{\text{phase}} = e_{\text{reform}} - (2e_{\text{combust}} + e_{\text{WGS}} + e_{\text{FT}})$$

$$e_{\text{phase}} = -\left(2e_{\text{combust}} + \frac{2}{3}\right)$$

Notice that e_{phase} is negative, this means that there is actually excess steam that will need to leave the process. This is to say that the process produces water. If the “Steam In” term was written as “Steam Out” on the right of the balance then e_{phase} would have been positive.

With all the extents written in this way it is then possible to perform the material balance for each chemical component and thereby calculate the “flows” of each component. This is represented in Table 4.2:

Table 4.2: Material flows of all chemical components in terms of extent of reaction

Component	material flow	
CH ₄	$e_{\text{reform}} + e_{\text{combust}}$	$1 + e_{\text{combust}}$
O ₂	$2e_{\text{combust}}$	$2e_{\text{combust}}$
H ₂ O	$e_{\text{reform}} - (2 * e_{\text{combust}} + e_{\text{WGS}} + e_{\text{FT}})$	$-(2e_{\text{combust}} + 2/3)$
-CH ₂ -	$e_{\text{reform}} + e_{\text{WGS}}$	4/3
CO	$e_{\text{reform}} + e_{\text{WGS}}$	4/3
H ₂	$e_{\text{reform}} - e_{\text{WGS}}$	8/3

In formulating Table 4.2 the extent of the combustion reaction has been chosen to be the degree of freedom. In principle any of the five extents could be chosen as the degree of freedom. The extents used here are between zero and one, it may seem that the mass flows would be far too small for any real process but at this stage of the synthesis all the mass flows can be easily scaled to any desired value.

It should be noted that the extent of the phase change reaction, according to Table 4.2, will always have a negative value. The phase change is operating in the opposite direction to what is expected. This means that there is an excess amount of steam present in the system. The overall process will, in fact, be producing water rather than consuming it.

What had previously been five degrees of freedom (for the material balance) has thus been reduced to only 1. The mass, energy and work balances can all be determined by choosing a value for the combustion reaction. It has been decided that the overall process should be exothermic with zero excess work. The value of combustion extent that will satisfy that requirement can be found using any variety of “goal finding” algorithms.

For now, ignore the effect of temperature (ie. leave them at the Carnot temperatures). The overall balances can be determined by choosing the combustion extent such that Gibbs free energy is zero and enthalpy is negative.

The value of combustion extent that satisfies the constraints is:

$$e_{\text{combust}} = 0.043$$

Taking this value into Table 4.2 allows the full component material balance to be completed, which in turn allows full energy and work balances to be completed. It is found that:



$$\begin{pmatrix} \Delta H_{\text{process}} \\ \Delta G_{\text{process}} \end{pmatrix} = \begin{pmatrix} -50.93 \\ 0 \end{pmatrix}$$

Currently all the balances have been solved and still no flow sheet exists. However, it is now possible to draw a first flow sheet, Figure 4.27:

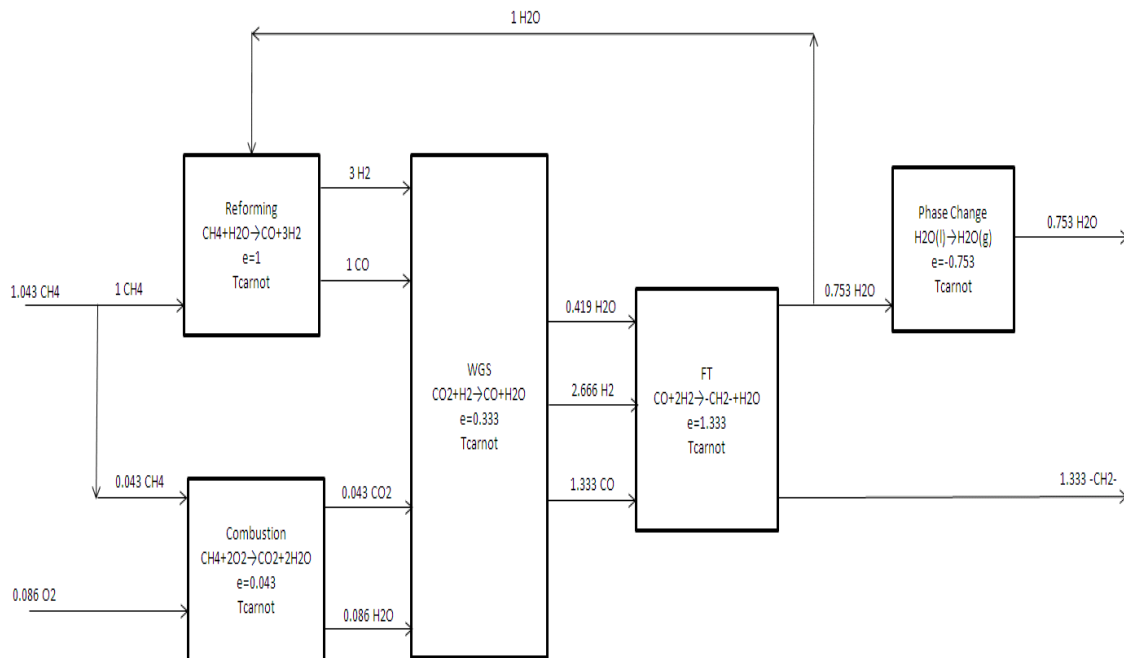

Figure 4.27: First draft Process flow sheet prior to investigation of temperature effects

Figure 4.27 shows what the flow sheet could look like. There are many issues still to consider.

Firstly, notice the appearance of the water recycle stream into the Reforming unit. This recycle stream came about from the overall material balance, by choosing the extent of the combustion reaction ($e_{\text{combust}}=0.043$) the amount of excess water was set to be 0.753 mol/s. However, the amount of water leaving the FT unit is 1.753 mol/s. There is more water leaving the FT unit than the overall material balance states needs to be converted back to liquid. By taking enough steam (1 mol/s) for the Reforming unit the left over steam becomes the exact amount predicted by the overall material balance.

Another issue is feeding some of the water product from the WGS unit into the FT unit. It might be worthwhile to remove that water and recycle it to Reforming before the FT unit, since you would not want water to be entering the FT unit.

Other issues include Temperature, Pressure and the production of pure components. These will be considered in the forthcoming sections.

4.3.4 The effects of temperature and chemical equilibrium

The analysis carried out thus far has considered all the reactions to be occurring at the Carnot Temperatures, which is to say that all the work for the process has been flowing with the heat. This would be convenient since the flows of heat and work would be satisfied simultaneously. However, it has already been established that Carnot Temperature is sometimes unworkable. Consider Table 4.3 which lists the Carnot Temperature for each of the independent material balances:

Table 4.3: Independent material balances and their Carnot Temperatures

Reaction	Balance	T _{carnot} (K)
Methane Reforming	$\text{CH}_4 + \text{H}_2\text{O} \rightarrow \text{CO} + 3\text{H}_2$	960.35
Combustion	$\text{CH}_4 + 2\text{O}_2 \rightarrow \text{CO}_2 + 2\text{H}_2\text{O}$	145792.87
FT Synthesis	$\text{CO} + 2\text{H}_2 \rightarrow \text{CH}_2 + \text{H}_2\text{O}$	655.47
Water-Gas Shift	$\text{CO}_2 + \text{H}_2 \rightarrow \text{CO} + \text{H}_2\text{O}$	974.18
Phase Change	$\text{H}_2\text{O}(l) \rightarrow \text{H}_2\text{O}(g)$	369.96

The Carnot Temperature for Methane Reforming is not an unreasonable one and need not be dismissed immediately. It can be kept, for now, as the working temperature until equilibrium is considered shortly.

The Combustion reaction is the most obvious example of an unworkable Carnot Temperature. Such unusable Carnot Temperatures are common for combustion reactions, some significantly lower temperature will need to be used. Combustion reactions can be considered to always proceed to completion so equilibrium is not a concern.

FT synthesis does not have an unworkable temperature but the length of hydrocarbon chains formed is known to decrease the higher the temperature. At 655K the product from FT synthesis would contain a large proportion of methane, which was the feed to the process. Using the feed, to produce the feed, defeats the purpose of designing a process at all. The hydrocarbon product chain length is affected by other issues such as catalyst selection, which is the subject of other research,^{21,22} and not the focus of this paper. Operating FT synthesis at temperatures closer to 473K will help promote longer chain lengths.

The temperature of the Water-Gas shift reaction is also not unreasonable. The choice of temperature would primarily depend on equilibrium and catalyst activity. The Carnot temperature can and should be used, if possible.

The Carnot Temperature for the Phase Change reaction is extremely close to the boiling point of water at atmospheric pressure. This temperature would be influenced by operating pressure. At this stage the process is still at atmospheric conditions, the Carnot Temperature is acceptable.

Two of the independent material balances have a dependency upon chemical equilibrium: Steam Reforming and Water-Gas shift.

How equilibrium changes with temperature is defined by the Van't Hoff equation:

$$\frac{d \ln K}{dT} = \frac{\Delta H}{RT^2} \quad (8)$$

Where:

- K is the equilibrium constant
- T is temperature
- ΔH is the enthalpy of reaction as calculated by equation [1]

Equation [8] can be integrated between the desired temperature and ambient conditions. To do this the equilibrium constant at ambient conditions needs to be known, which is given by:

$$\Delta G_0 = -RT_0 \ln K_0 \quad (9)$$

Where:

- K_0 is the equilibrium constant at ambient conditions
- T_0 is the ambient temperature
- ΔG_0 is the Gibbs free energy as calculated by equation [2]

The equilibrium constant can then be related to the material balance (and extent of reaction) by:

$$K = \frac{\text{Products}}{\text{Reactants}} \quad (10)$$

Beginning with the Steam Reforming reaction, it is desired to react all the methane present. In other words the reaction should proceed to completion. It can be found that this does not happen at temperatures below 1000K. This means the Carnot Temperature is too low to allow complete conversion of methane.

There are two options to ensure the reaction can proceed to completion. One is to raise the temperature high enough. However, raising the temperature too high has implications for materials, dusting and carbon deposition.

Another option is to feed excess water to the Steam Reforming reaction to force the equilibrium towards the products by Le Chateliers Principle. Recall that the overall material balance is set by the constraints placed on the energy and work balances. This means that feeding excess water will not have any effect on the amount of water leaving the process, the effect will be on the size

of the water recycle stream in Figure 4.27. This will later have an effect on the work flows required for separations.

One way to proceed from here would be to choose a temperature for Steam Reforming and then ensure that enough water is present to ensure complete reaction. The question becomes what temperature to choose? Simulations performed on the chemical equilibrium showed any temperature between 1200K and 1800K works admirably. These temperatures are high enough to avoid needing an extremely large water excess for complete reaction and low enough to avoid problems with materials of construction.

Consider using a temperature of 1273K. It can be found that feeding an extra 30% of water can ensure the reaction proceeds essentially to completion. This means that for every 1 mole of methane there will be 1.3 moles of water fed to the system. Many systems advocate a higher ratio of water. This can be accommodated easily since any additional water at that temperature will simply ensure the reaction proceeds even closer to 100% completion.

Next, consider the equilibrium of the Water-gas shift reaction. It has been shown that the extent of the Water-gas shift reaction must be a third of the extent of the Reforming reaction to ensure the correct 2:1 synthesis gas ratio.

Using Equations [8], [9] and [10] along with the extent balances it can be found that, for the combustion extent in Figure 4.27 ($e_{\text{combust}} = 0.043$), the Water-gas shift extent of $e_{\text{WGS}} = 0.333$ will only be reached when the temperature reaches approximately 1700K.

A temperature of 1700K is too high, to lower the temperature the feeds to the reaction need to be modified. The amounts of Carbon Monoxide and Hydrogen are set by the extent of the reforming reaction so they cannot be modified for the purposes of the equilibrium. Removing all the water before the Water-gas shift is one possibility but a far more interesting option lies in the amount of Carbon Dioxide fed to the Water-gas shift reactor. Due to the desired direction of the Water-gas shift reaction, by supplying an excess Carbon Dioxide to the Water-gas shift will allow the desired extent to be reached at a lower temperature.

The temperature of the Water-gas shift could be controlled by the amount of Carbon Dioxide supplied to the reaction. Supplying increasing quantities of Carbon Dioxide would allow the reaction to be operated at lower temperatures. There is a limit on how large a flow of Carbon Dioxide could be handled, which depends primarily on the separation required after the Water-Gas Shift unit, but the important result of this step is that the overall process now has the potential to use Carbon Dioxide as a feed.

One may have realized that the Methane Reforming reaction has excess water (30% or more for complete reaction) and Carbon Monoxide and Hydrogen as products. There is nothing preventing the Carbon Monoxide and Water present of undergoing some Water-gas shift reaction before reaching the Water-gas shift unit. By considering Le Chateliers principle it could be deduced that this “early” Water-gas shift reaction will actually have the effect of producing even more hydrogen in the Reforming unit. The extent of reaction required in the Water-gas shift unit

will then be higher than initially thought, resulting in a higher reaction temperature or an even larger Carbon Dioxide supply.

The effect of equilibrium and the early Water-gas shift will all have an effect on the overall material balance of the process. Let the extent of the early Water-gas shift reaction be given by e_{eWGS}

Repeating the material balance, in order to attain a 2:1 Hydrogen to Carbon Monoxide ratio:

$$H_2 = 2CO$$

$$(3e_{reform} - e_{eWGS} - e_{WGS}) = 2(e_{reform} + e_{eWGS} + e_{WGS})$$

$$e_{WGS} = \frac{e_{reform}}{3} - e_{eWGS}$$

With the additional Water-gas shift occurring, with the Reforming reaction, the extent of reaction required by the Water-gas shift unit still needs to be one third of the reforming extent and then the sum of the early Water-gas shift extent.

The overall material balance for the process can be summarized by Table 4.4:

Table 4.4: Overall Component Material balance modified for equilibrium and “early” Water-gas shift

Component	material balance	
CH ₄	$e_{reform} + e_{combust}$	$1 + e_{combust}$
O ₂	$2e_{combust}$	$2e_{combust}$
H ₂ O	$(e_{reform} + e_{eWGS}) - (2 * e_{combust} + e_{WGS} + e_{FT})$	$-2/3 - 2e_{combust}$
-CH ₂ -	$e_{reform} + e_{WGS} - e_{eWGS}$	$4/3$
CO	$e_{reform} + e_{WGS} - e_{eWGS}$	$4/3$
H ₂	$3e_{reform} - e_{WGS} + e_{eWGS}$	$8/3$
CO ₂	$X - (X + e_{combust} + e_{eWGS} - e_{WGS})$	$-e_{combust} + 1/3$

The symbol “X” in Table 4.4 denotes the additional Carbon Dioxide added to the system to push the extent of reaction for the Water-gas shift unit to the required value. Notice the excess feeds do not have any impact on the overall material balance, since any unused material can be recycled.

The additional of the “early” Water-gas shift reaction also does not have any appreciable effect on the overall material balance for the process. As long as the overall constraints on the process (like the 2:1 Hydrogen: Carbon Monoxide ratio) still exist the *overall* balance will be unchanged it is the balances over the individual units that will be effected.

The extent of reaction for the early Water-gas shift reaction depends entirely on the temperature chosen for the Reforming unit, since the Water-gas shift reaction is not sensitive to pressure and the Reforming reaction proceeds to completion. Once a temperature for the Reforming unit is chosen the extent of the early Water-gas shift can be calculated from Equations [8], [9] and [10]. As before, the extent of the Combustion reaction is chosen such that the overall process is exothermic with zero work.

Before the flow sheet synthesis proceeds the operating temperatures that will be used are summarized in Table 4.5:

Table 4.5: The process reactions and their chosen operating temperatures

Reaction	Balance	T (K)
Methane Reforming	$\text{CH}_4 + \text{H}_2\text{O} \rightarrow \text{CO} + 3\text{H}_2$	1273
Early WGS	$\text{CO}_2 + \text{H}_2 \rightarrow \text{CO} + \text{H}_2\text{O}$	1273
Combustion	$\text{CH}_4 + 2\text{O}_2 \rightarrow \text{CO}_2 + 2\text{H}_2\text{O}$	1273
FT Synthesis	$\text{CO} + 2\text{H}_2 \rightarrow -\text{CH}_2 - + \text{H}_2\text{O}$	473
Water-Gas Shift	$\text{CO}_2 + \text{H}_2 \rightarrow \text{CO} + \text{H}_2\text{O}$	974
Phase Change	$\text{H}_2\text{O}(l) \rightarrow \text{H}_2\text{O}(g)$	370

A temperature of 1273K was chosen for the Methane Reforming reaction to allow the reaction to proceed to completion without *requiring* too much excess water while at the same time not being too hot to have implications for materials.

The early WGS reaction has the same temperature as the Methane Reforming since early WGS depends solely upon the temperature of the Methane Reforming due to both reactions occurring in the same unit.

The Combustion reaction temperature has been chosen to be the same as Methane Reforming and early WGS. This is actually one of the degrees of freedom available to the designer. In this case, the temperature of 1273K was chosen for a specific reason which will be discussed in greater detail further into the paper.

For FT synthesis, the temperature of 473K was chosen since temperatures higher than this tend to favor the formation of shorter hydrocarbon chains. The chosen temperature tends to favor the production of chain lengths within the region of diesel cuts.

The temperature of the Water-gas shift unit was chosen to be the Carnot Temperature for the reaction. The Water-gas shift reaction, as written, is endothermic and requires the addition of work. By choosing the Carnot Temperature as the operating temperature, adding the required heat will simultaneously add the required work. This was done for the sake of heat and work flow convenience. This temperature could be modified to meet requirements of catalysts or Carbon Dioxide supply

The Phase Change temperature was chosen to be the Carnot Temperature. This is the boiling point for water at atmospheric pressure. The overall process is producing water so this is acceptable. Some modification could be made in order to allow for the operating conditions of steam turbines, etc.

It is now possible to recalculate the ΔH and ΔG for all of the process reactions. ΔH can be calculated, as before, by using Equation [1]. With most of the temperatures now different from the Carnot temperatures, ΔG can no longer be determined using Equation [2]. This time Equation [4] can be used with the chosen temperature and the value of ΔH from Equation [1].

This is summarized in Table 4.6:

Table 4.6: The energy and work balances for the process reactions with ΔG modified for temperature

Reaction	Balance	H (W)	G(W)
Methane Reforming	$\text{CH}_4 + \text{H}_2\text{O} \rightarrow \text{CO} + 3\text{H}_2$	206.12	157.87
Early WGS	$\text{CO}_2 + \text{H}_2 \rightarrow \text{CO} + \text{H}_2\text{O}$	41.19	31.55
Combustion	$\text{CH}_4 + 2\text{O}_2 \rightarrow \text{CO}_2 + 2\text{H}_2\text{O}$	-802.35	-614.53
FT Synthesis	$\text{CO} + 2\text{H}_2 \rightarrow -\text{CH}_2 - \text{H}_2\text{O}$	-152.32	-56.36
Water-Gas Shift	$\text{CO}_2 + \text{H}_2 \rightarrow \text{CO} + \text{H}_2\text{O}$	41.19	28.59
Phase Change	$\text{H}_2\text{O}(l) \rightarrow \text{H}_2\text{O}(g)$	44.01	8.56

As expected the ΔG for the reactions that had their temperatures altered from the Carnot Temperatures has changed from what was shown in Table 4.1. Due to the change in temperature, the amount of work that the heat is capable of carrying has changed. It can also be seen that the “Early” Water-gas shift reaction has the same ΔH as the Water-gas shift reaction but a different ΔG . Even though they are the same reaction they take place at different temperatures.

The target for the overall process is still exothermic with no excess work, as represented by point A on Figure 4.26. Due to the changes in temperature the point A of Figure 4.26 will move but will always remain on the axis.

This target can be represented by the following vector addition:

$$\begin{pmatrix} -\Delta H_{process} \\ 0 \end{pmatrix} = \begin{pmatrix} \Delta H_{reform} \\ \Delta G_{reform}(1273K) \end{pmatrix} + e_{combust} \begin{pmatrix} \Delta H_{combust} \\ \Delta G_{combust}(1273K) \end{pmatrix} + e_{eWGS} \begin{pmatrix} \Delta H_{eWGS} \\ \Delta G_{eWGS}(1273K) \end{pmatrix} \\ + \left(\frac{1}{3} - e_{eWGS} \right) \begin{pmatrix} \Delta H_{WGS} \\ \Delta G_{WGS}(974K) \end{pmatrix} + \left(-\frac{2}{3} - 2e_{combust} \right) \begin{pmatrix} \Delta H_{phase} \\ \Delta G_{phase}(370K) \end{pmatrix} + \left(\frac{4}{3} \right) \begin{pmatrix} \Delta H_{FT} \\ \Delta G_{FT}(473K) \end{pmatrix}$$

Once temperatures are selected there remains only one degree of freedom in the vector addition: the extent of the combustion reaction, since the extent of the “early” Water-gas shift reaction

depends entirely on the temperature of the Reforming reaction. Thus the extent of the combustion reaction needs to be chosen such that the process is exothermic with no excess work.

Doing this and inferring the extents of the other reactions gives:

$$e_{reform} = 1$$

$$e_{combust} = 0.14$$

$$e_{eWGS} = -0.05$$

$$e_{WGS} = 0.38$$

$$e_{FT} = 1.33$$

$$e_{phase} = -0.94$$

The negative extent for the phase change reaction implies that the reaction is proceeding in the opposite direction to the direction as written. This means that the process is actually producing water. A similar argument could be applied to the two Water-gas shift reactions, the negative sign for the “early” Water-gas shift implies the direction of the reaction is towards the production of hydrogen which is opposite to the direction the reaction *was written*.

With all the reaction extents known the material balance can be calculated using Table 4.4. Assuming that every reaction takes place in its own unit a new version of the Flow sheet can be drawn as Figure 4.28:

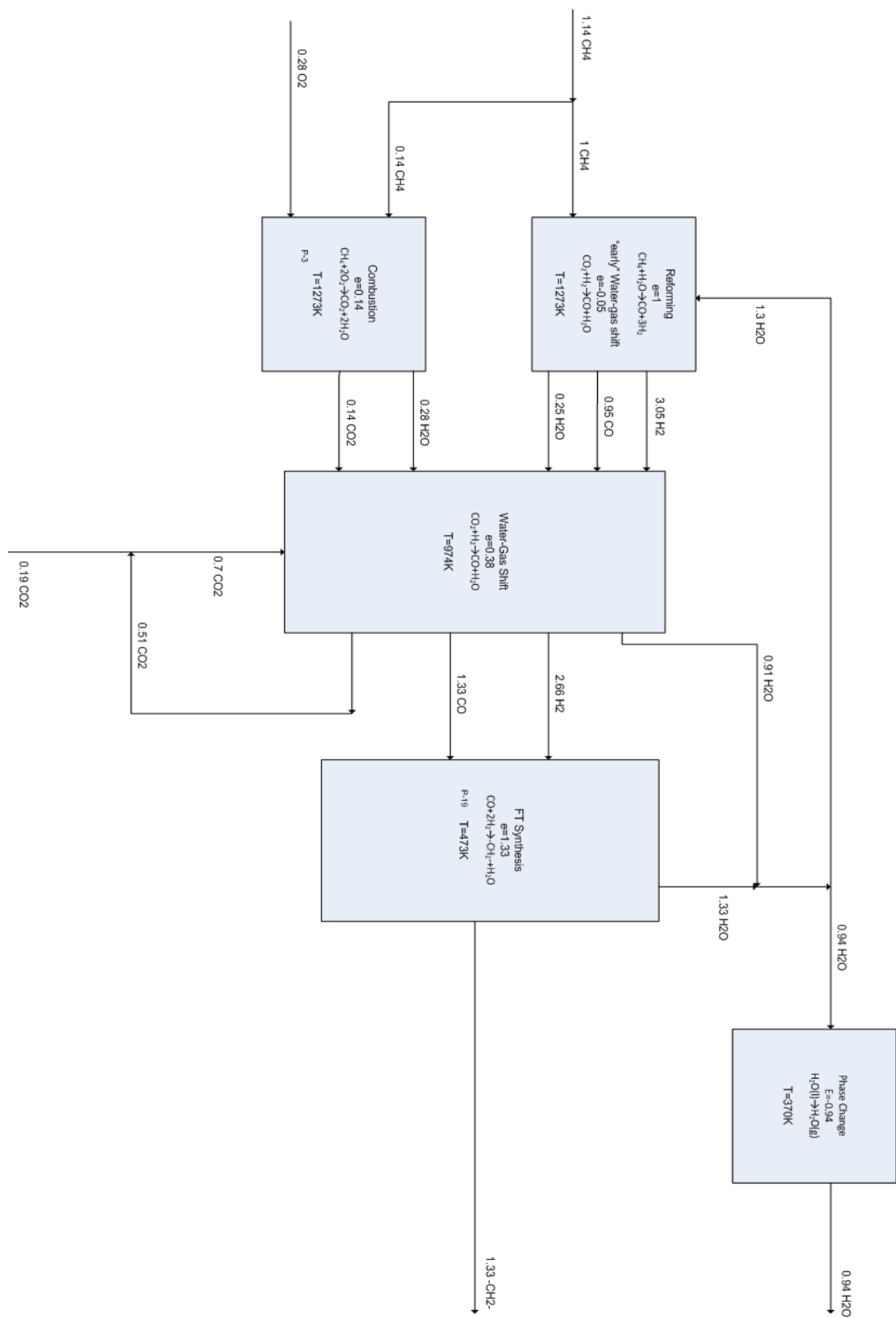

Figure 4.28: Second draft Process flow sheet with inclusion of operating temperature, equilibrium and recycles

The flow sheet of Figure 4.28 is an overall exothermic process that does not produce any excess work. In addition to this, it uses 0.19 mol/sec of Carbon Dioxide as a feed.

This is not the only layout possible for even this second draft. The water from the Water-gas shift unit has been removed before being fed into the FT synthesis unit, which is a change from Figure 4.27. Un-reacted Carbon Dioxide is recycled directly back to the WGS unit. It would be a possibility to first feed the un-reacted carbon dioxide into FT synthesis as source of carbon feed, along with Carbon Monoxide. This would be equivalent to adding another reaction to the overall system which would likely make the amount of Carbon Dioxide consumed by the process even higher. The un-reacted Carbon Dioxide could even be fed back to the Reformer unit first to influence the “early” Water-gas shift reaction.

Recall that it was mentioned that the temperature of the combustion reaction was chosen to be the same as the Reforming and “early” Water-gas shift reaction for a specific reason. The reason provides an example of how the GH-space can begin to tie in with the selection of specific process equipment. By operating Reforming, Combustion and “early” Water-gas shift all at the same temperature the possibility exists for all three of those reactions to be carried out in one piece of equipment. An actual piece of equipment exists that approximates that, called the Autothermal reformer. Steam reformers also exist where the reactions are not combined into a single unit.

There are advantages and disadvantages involved in which method of reforming is used and is the subject of a significant amount of existing research,^{23,24,25}. In the scope of synthesizing a flow sheet using the GH-space any of the above reforming methods could be catered to.

Since autothermal reforming tends to have fewer problems with carbon deposition,²⁶ the Reforming, “early” Water-gas shift and Combustion reactions will all be combined into a single unit. Thus the third draft of the process flow sheet is the combination of those 2 units in Figure 4.28 to create Figure 4.29. This combined unit will henceforth be referred to as the “Reformer”. The overall process could then be considered to consist of 4 “reaction” units: The Reformer, Water-gas Shift, FT synthesis and Phase Change. Note that the extent in the Phase Change unit is quoted as negative; this means that the process is producing liquid water and not steam.

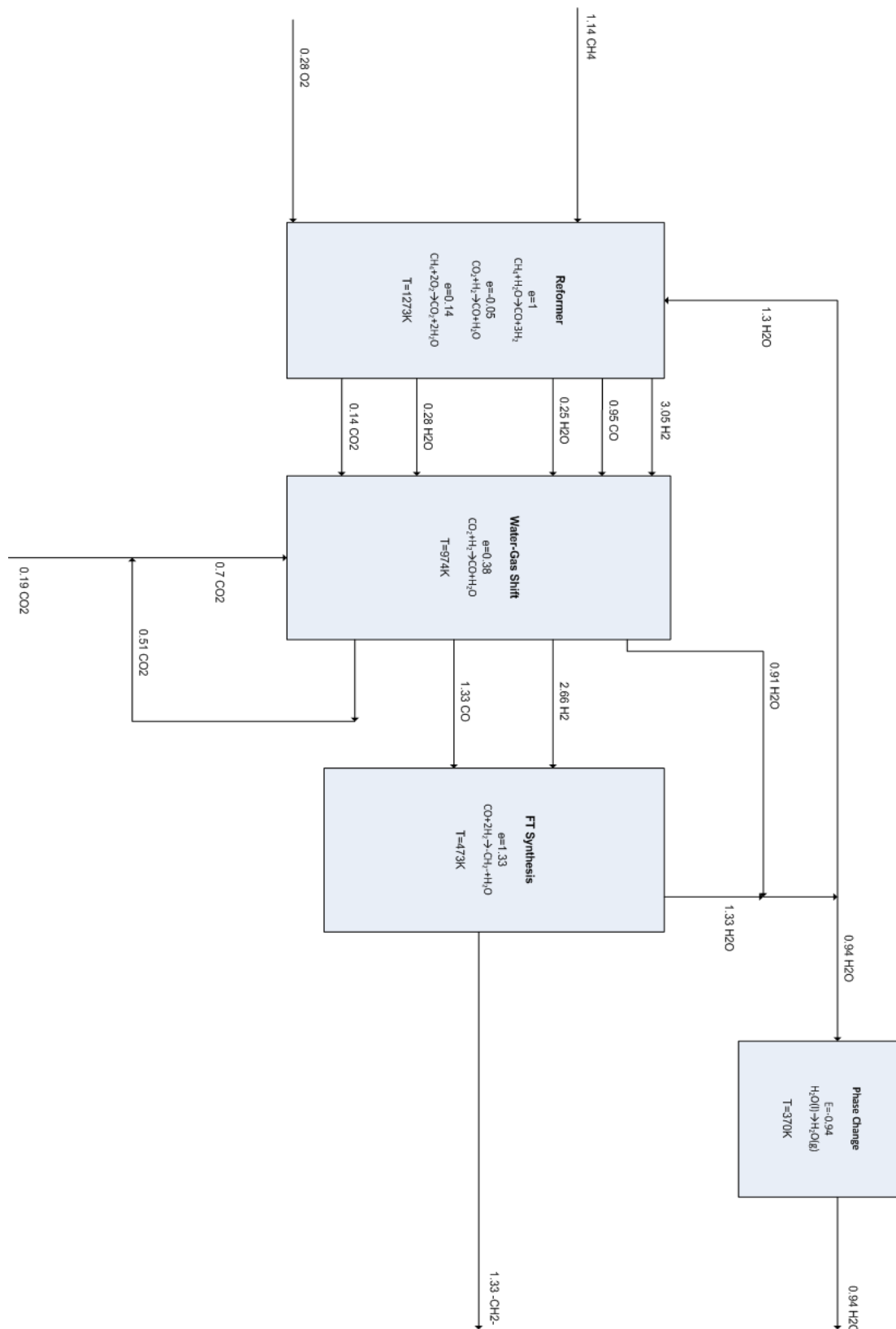

Figure 4.29: Third draft Process flow sheet showing the combination of the Reforming, “early” Water-gas Shift and Combustion reactions

Each of the units can be represented on the GH-space. First Consider the Reformer unit, since all the temperatures are the same the 3 reaction vectors will all lie on top of each other. For the sake of illustration however, consider the Reforming reaction first, Figure 4.30:

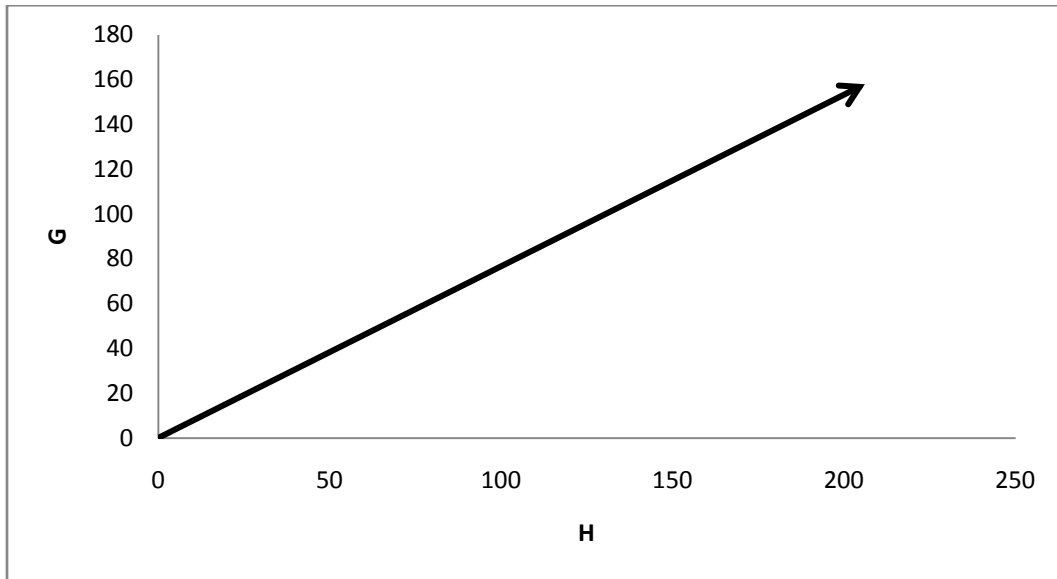

Figure 4.30: Reforming reaction vector at 1273K and $e=1$

The Reforming reaction at a temperature of 1273K and an extent of reaction of 1 will have a length and direction shown in Figure 4.30. The effect of including the Combustion reaction will be the vector addition of Reforming and Combustion, Figure 4.31:

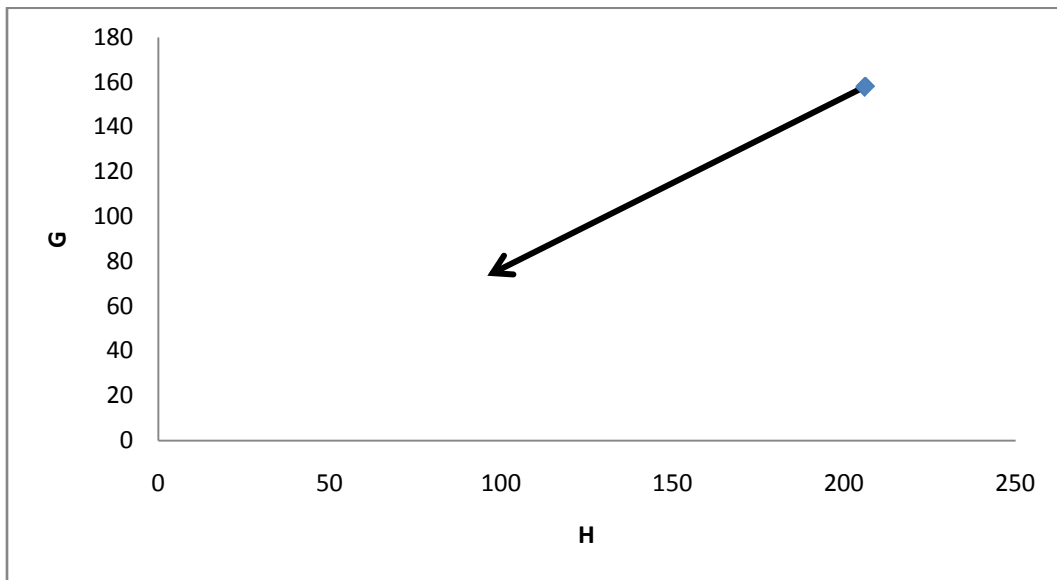

Figure 4.31: Vector addition of Combustion ($e_{\text{combust}}=0.14$) and Reforming

The extent of reaction for the “early” Water-gas shift reaction is small ($e_{\text{eWGS}}=-0.05$) in comparison to the extents for Reforming and Combustion which means that vector addition will

be difficult to illustrate. However the resultant vector for the Reformer unit can be drawn onto Figure 4.32:

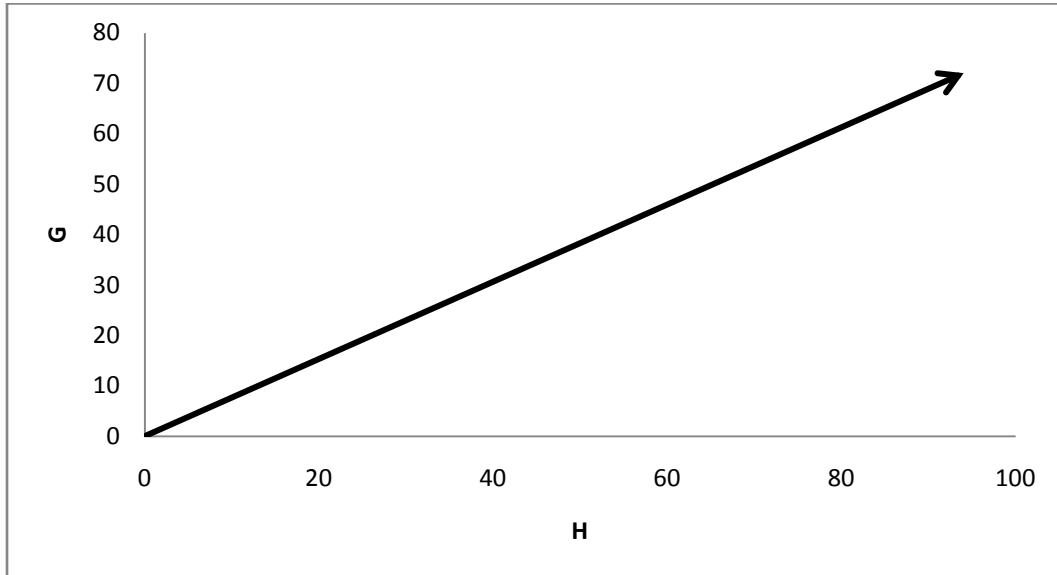

Figure 4.32: Resultant vector for the Reformer unit, composed of the vectors for Reforming, Combustion and "early" Water-gas shift

Similarly, the resultant vectors for the other process units can also be drawn onto the GH-space. Vector addition can then be done with each of these unit vectors and the resultant vector for the overall process and be drawn, Figure 4.33:

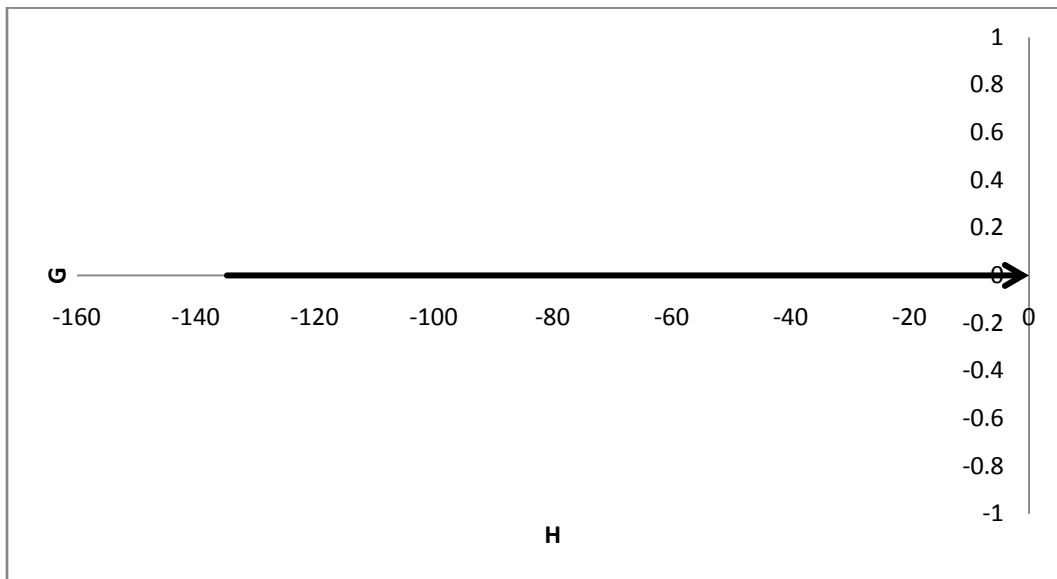

Figure 4.33: Resultant vector for the overall Process. Composed of Reforming, "early" WGS, Combustion, WGS, FT synthesis and Phase change

With the information contained in the unit vectors and the resultant process vector it is possible to illustrate the flows of heat and work within the process, Figure 4.34:

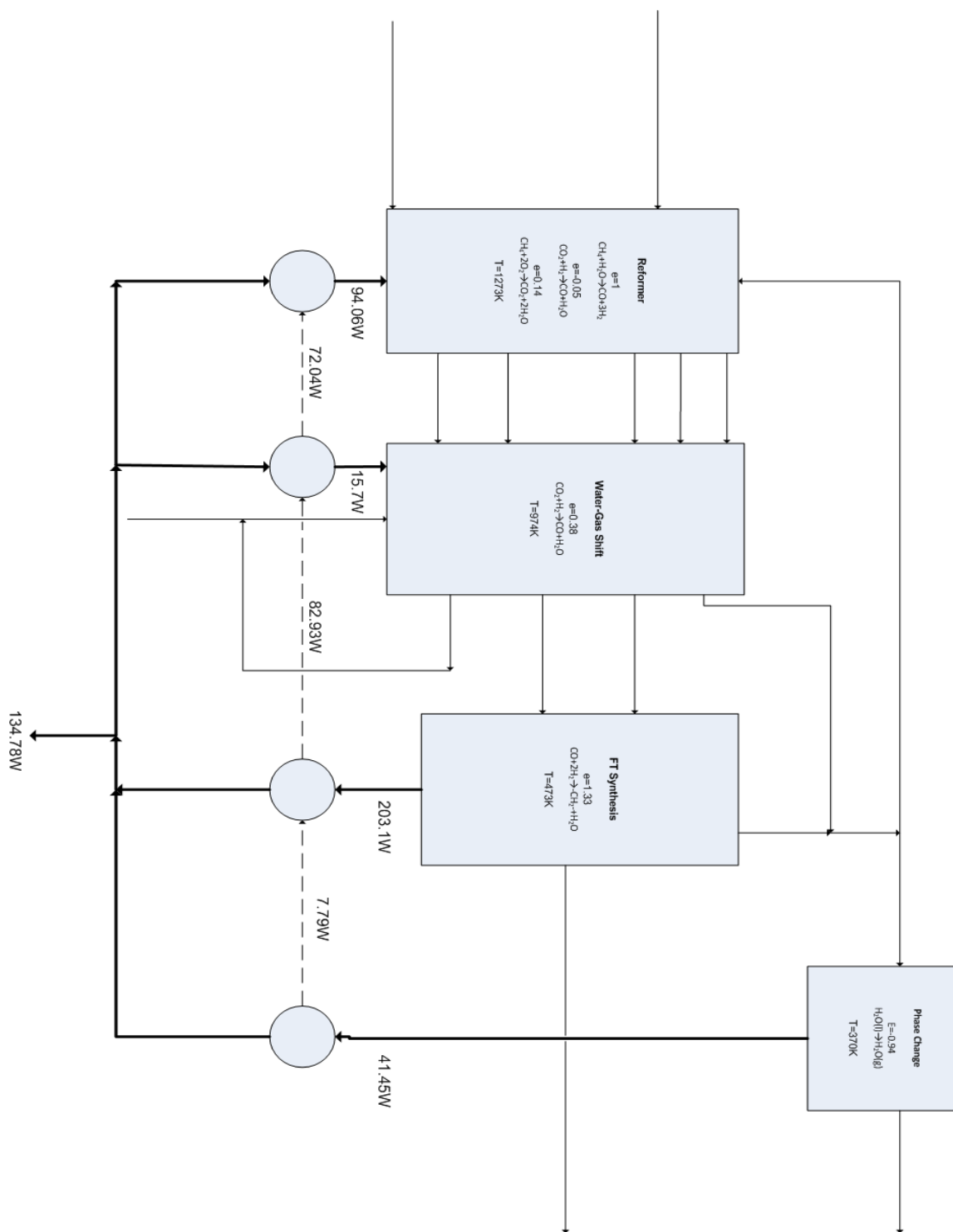

Figure 4.34: Third draft Process flow sheet showing the flows of heat (solid bold lines) and work (dashed lines) between the process units

Figure 4.34 shows the draft flow sheet of Figure 4.29 detailing how heat and work would flow between the units. Heat flows are denoted by the solid bold lines and work flows are denoted by dashed lines. Once again, as discussed with Figure 4.18, the circular units can be interpreted as heat engines. While heat and work flows are drawn separately for visualization they flow together.

Thus far the flow sheets have only considered the production of pure components. The next step will be to consider the effects of mixing which will, in turn, lead to the consideration of separations.

4.3.5 The effect mixing and separation

Consider the reaction vector for the Reforming reaction, Figure 4.35:

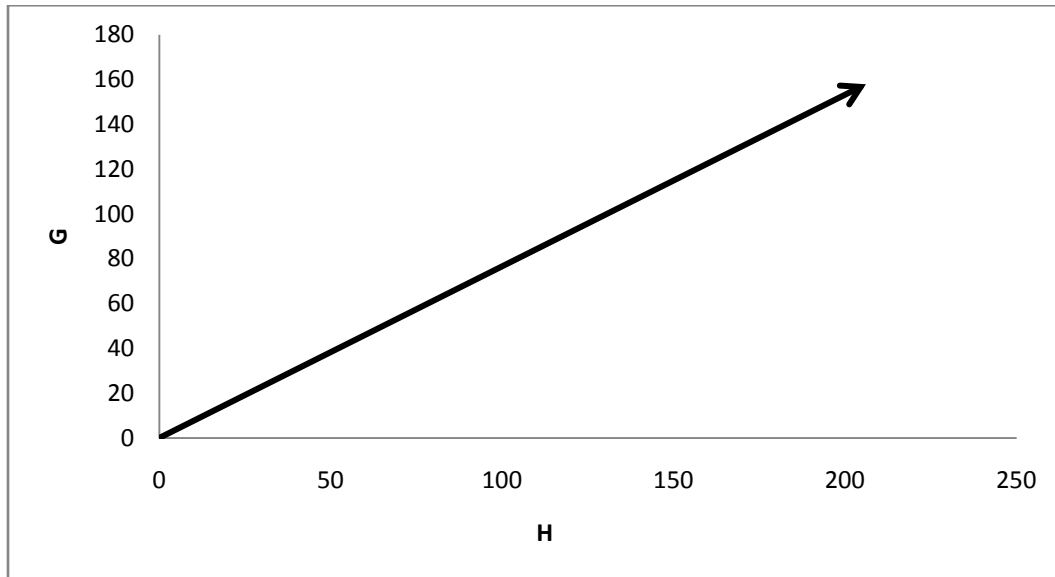

Figure 4.35: The Reforming reaction vector for all extents from 0 to 1 at 1000°C

The reaction vector in Figure 4.35 and all the reaction vectors so far, have represented the production of pure components. At any given extent of reaction the material balance is known and Equation [7] can be used to find the work of mixing the pure component products, then adding these to the reaction vector of Figure 4.35, the overall reaction vector that includes the effect of mixing can be drawn as Figure 4.36:

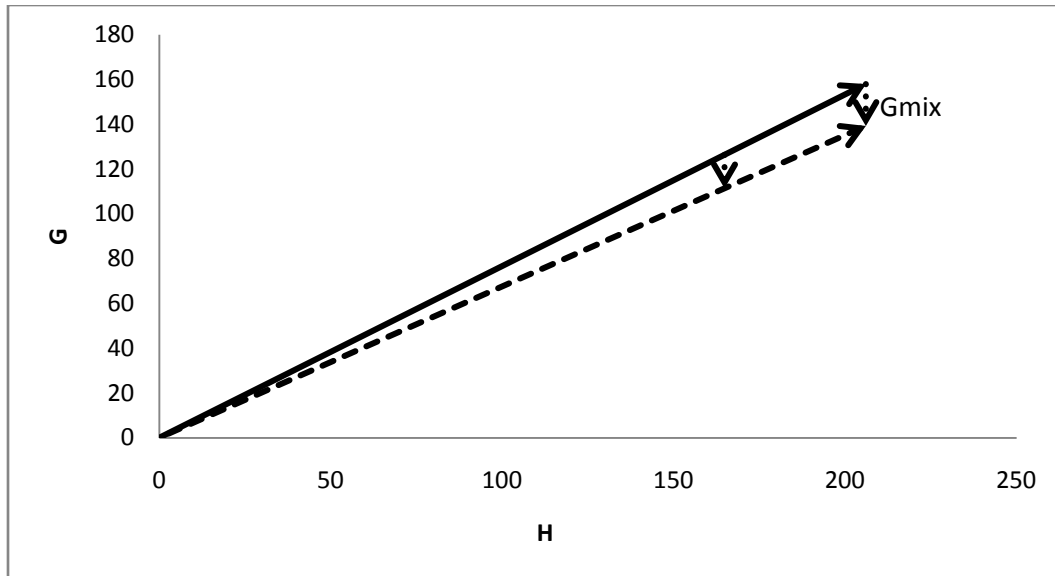

Figure 4.36: The effect of mixing on the Reforming reaction vector

Like temperature, mixing has an influence on the direction of the reaction vector. It is important to note that Figure 4.36 applies when the reaction always proceeds to completion. In other words, there are no excess reactants supplied to the reaction, only the exact amount required for a particular extent of reaction. If excess reactants are present the reaction vector will begin to bend. This means that, for all the reaction extents where there are excess reactants and mixing is included, the overall reaction vector will become a curve. However, this overall curve is composed of the vector addition of the pure component reaction and the mixing of the products at all possible extents. It is therefore more convenient to consider pure component reaction and mixing as two separate vectors rather than a single curve.

Although Figure 4.12 and Figure 4.36 are for different reactions it can still be seen that the effect of mixing is small compared to the effect of temperature.

Returning to the Third Draft Process flow sheet, Figure 4.29, it can be assumed that the feed to the Reformer unit will be pure components but there will be mixing effects on the products from the Reformer, as well as the products from Water-Gas shift and FT-synthesis.

Consider the resultant vector of the Reformer unit, Figure 4.32. Using the material balance with Equation [7] the mixing vector can be determined and added to the Reformer resultant vector, Figure 4.37:

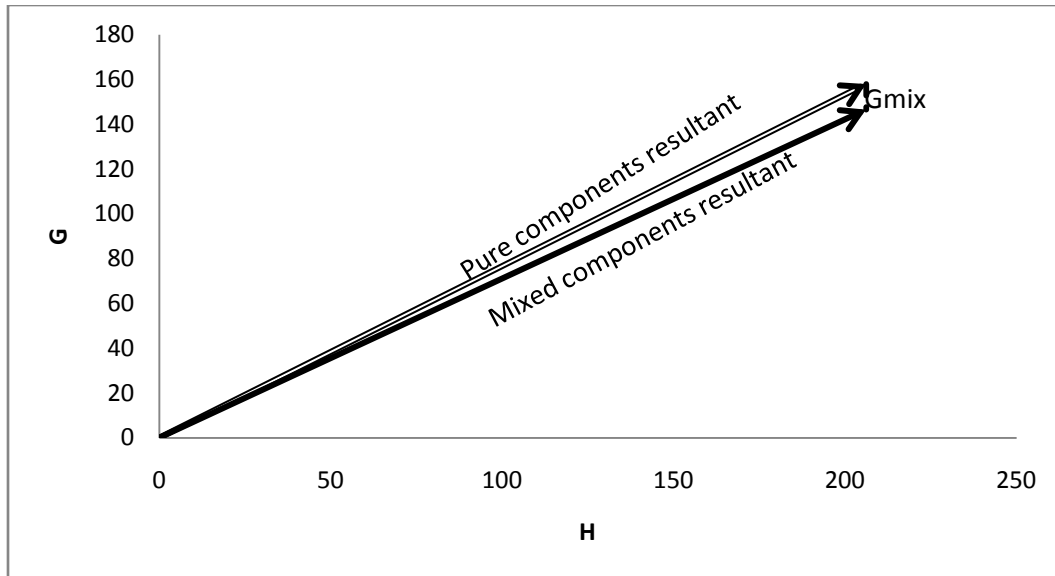

Figure 4.37: The Reformer resultant vector including the mixing effect for the products from Steam Reforming, Combustion and "early" WGS

In Figure 4.37, the pure component resultant vector (Figure 4.32) has been modified by the inclusion the work of mixing.

The effect of these mixing vectors can then be included in the resultant vectors for all of the process units. Before the overall process vector is calculated however it is sensible to consider the need for separations.

By considering Figure 4.29 it can be seen that Water and Carbon Monoxide needs to be separated after the Water-Gas shift unit (before FT synthesis) in order to provide the necessary recycles. In addition separation of water from the hydrocarbon product is necessary after FT synthesis.

This provides another early connection to real systems. The separation present after synthesis gas production can be considered to be an early estimation of a Gas Cleanup section. The separation after FT synthesis would be an early estimation of Cut separation/knockout. Both of these separation sections exist in actual Fischer-Tropsch plants.

Separation vectors can be calculated in the same way as the mixing vectors were calculated, by the use of Equation [7]. Care needs to be taken in separation however since the vector will have a direction opposite the mixing vectors.

One may notice that, before even drawing the vectors, the vectors for mixing and separation will always be exactly equal if the components are separated completely and perfectly. This means that the work of separation will always function to undo the work of mixing. In other words, the separation vector will always attempt to cancel out the mixing vector but will only ever succeed in doing so when all components are made pure. Note that while the vectors might behave in this way, it does not imply that the work of mixing can be used to run the separations. Mixing components to provide the work to separate those same components does not make sense.

However, the work of mixing is still present within the process it just cannot be harnessed to power a separator but it could be harnessed in another way.

It should also be noted that in these calculations the mixing and separations have all been considered to be ideal. Specific pieces of separation equipment might have clearly defined enthalpies. The selection of specific pieces of equipment is not the focus of this paper but the GH-space is capable of including such details as they are required.

It is now possible to determine all the vectors for the reactions, mixing and separation and determine the resultant vector for the entire process, Figure 4.38:

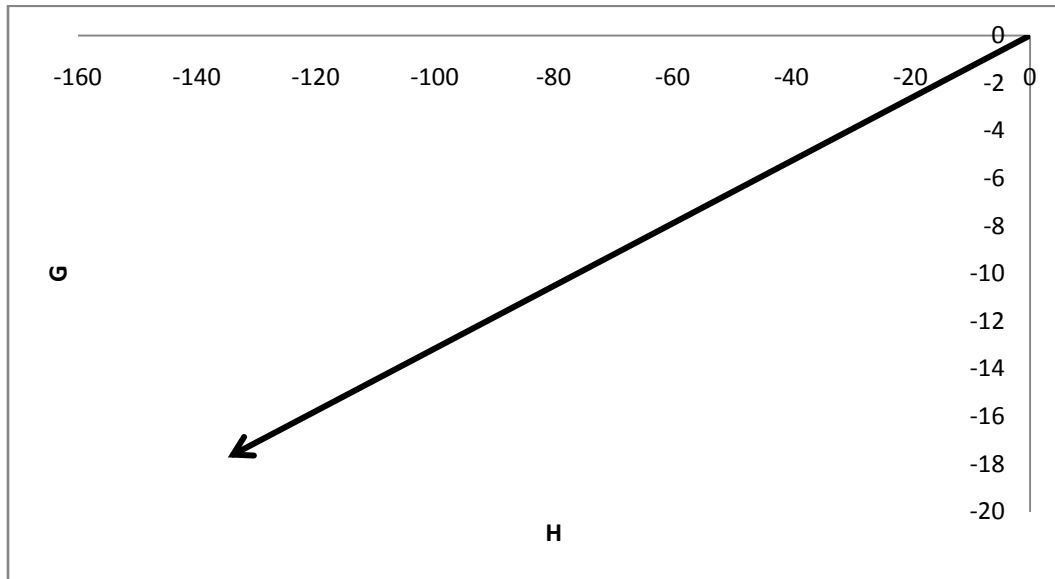

Figure 4.38: The overall process resultant vector including all the reactions, mixing and separations

It is immediately apparent from Figure 4.38 that things have changed. With the inclusion of mixing and separations the overall process has now become overall exothermic and work producing. There is now an excess work within the process.

The fourth draft process flow can also be drawn as Figure 4.39; all that has been done is mixing the streams and adding separators after the Water-gas shift unit and the FT synthesis unit.

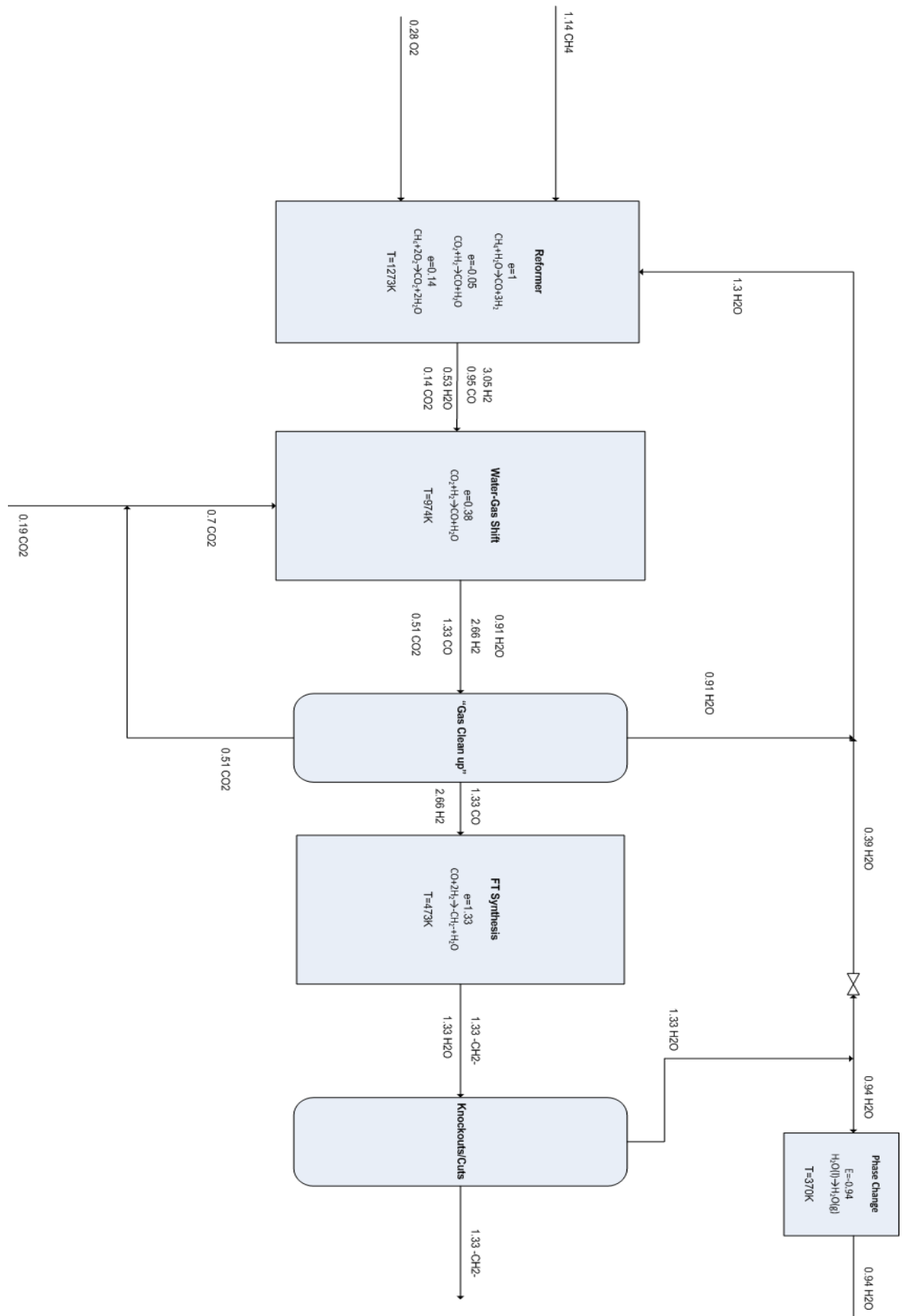

Figure 4.39: Fourth draft Process flow sheet including separators after syngas production and FT synthesis

The overall balances for the process depend on two major variables: the extent of the combustion reaction and the temperature of each of the reaction units.

It might be possible to change the extent of the combustion reaction such that the overall process will once again have no excess work. The problem there is that it requires the work of mixing to provide power to the other units of the process, as already discussed this has logic flaws, especially since the unit that requires most of the work is the Reformer and the mixing appears in the system after that unit. Another option would be to change the temperatures of some or all of the process reaction units. This is certainly an option; the major effects will be on the reaction equilibrium. In order to maintain the necessary reaction extents the size of the recycle streams would need to change, there is a limit to the relative sizes of these recycles. If the temperatures become high enough the process will begin to produce Carbon Dioxide rather than consuming it, if temperature becomes low enough the process will begin consuming water rather than producing it.

However, the questions now are: Is having some excess work in the process a bad thing? How much excess is too much?

To take those questions into consideration the last process variable needs to be taken into account, the pressure.

4.3.6 Excess work recovery

Thus far the entire process flow sheet has been operating at atmospheric pressure. Thermodynamically speaking this is entirely possible. It would even be desirable from a construction perspective in that pressure vessels would not be required, although this would lead to large gas volumes and thus leading to considerations in equipment sizing, while sizing will become an important consideration it is not covered in this research.

By including mixing and separations to create the Fourth draft of the process flow sheet it was found that the overall process becomes exothermic and work producing. It would be possible to simply leave the process as is. The process would perform its function even with this excess work simply being ignored as “lost work”. Simply rejecting excess work into the environment has environmental impact implications. It represents the process performing work upon its surroundings. A better option would be to attempt to recover this excess work as real work.

It has already been shown that integrating compressors with turbines can have the net effect of adding or recovering work from a process as real work.

It is known that there is excess work that needs to be recovered in the Fourth draft flow sheet. It is also known that in order to recover work from a process more gas must leave the process than enter it. Inspection of Figure 4.39 shows that no gas leaves the overall process at all. Operating the entire process at higher pressure would have the effect of adding work to the process, thereby increasing the excess that must be rejected. It appears that operating the process at pressure is not

a means to recover the excess work, changing operating temperatures to decrease the lost work seems to be a better option.

It might be tempting to abandon increased pressure operation at this point but if one closely investigates Figure 4.39 it could be seen that more gas leaves the syngas generation section than enters it. This is to say that there is more gas exiting the “Gas Clean up” separator than there is gas entering the Reforming unit.

If only that section of the process was operated at a higher pressure than excess work could be recovered from that section and the rest of the process could remain at atmospheric pressure.

The quantity of work that needs to be recovered has a specific value as shown in Figure 4.38 and the material balance over the syngas production section is given in Figure 4.39. This data can be used in Equation [6] and the required pressure for the recovery of this work can be calculated.

The calculation shows that a pressure of 20 atmospheres, for the syngas production section, needs to be 20 atmospheres to recover all of the excess work. This could be represented on the GH-space as Figure 4.40:

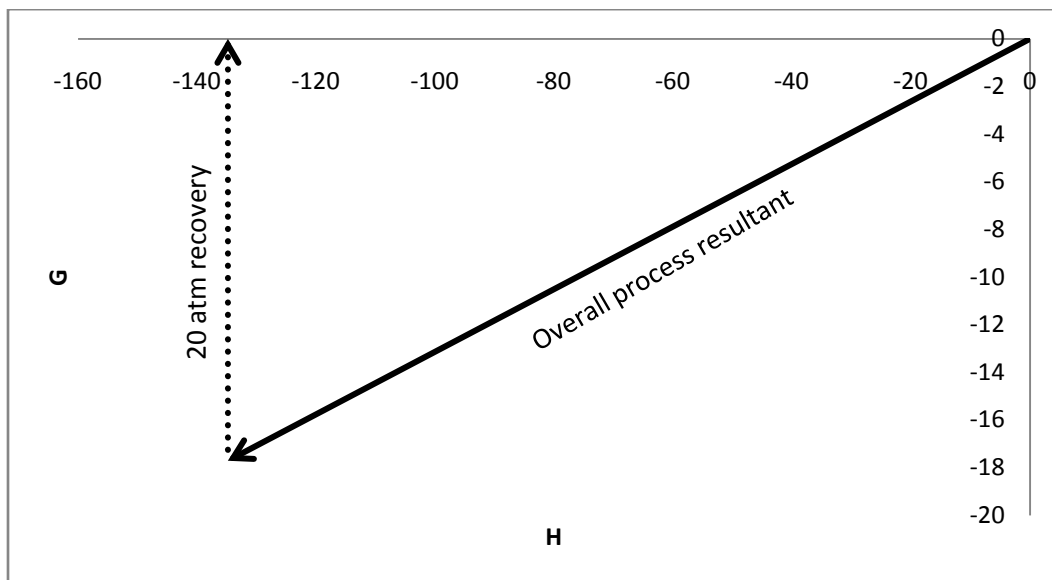

Figure 4.40: Overall process resultant vector with the work recovery at 20 atm

Figure 4.40 can be somewhat misleading. It seems to imply that the overall process is once again overall exothermic with no excess work, this is not the case. The overall process still produces excess work, the 20 atmospheres pressure allows this work to be recovered as real work (as electricity in this case). So the process is now overall exothermic with no *lost* work.

Since 20 atmospheres is not unreasonable it can be used to create the Fifth draft of the process flow sheet, Figure 4.41 and the heat and work flows in Figure 4.42:

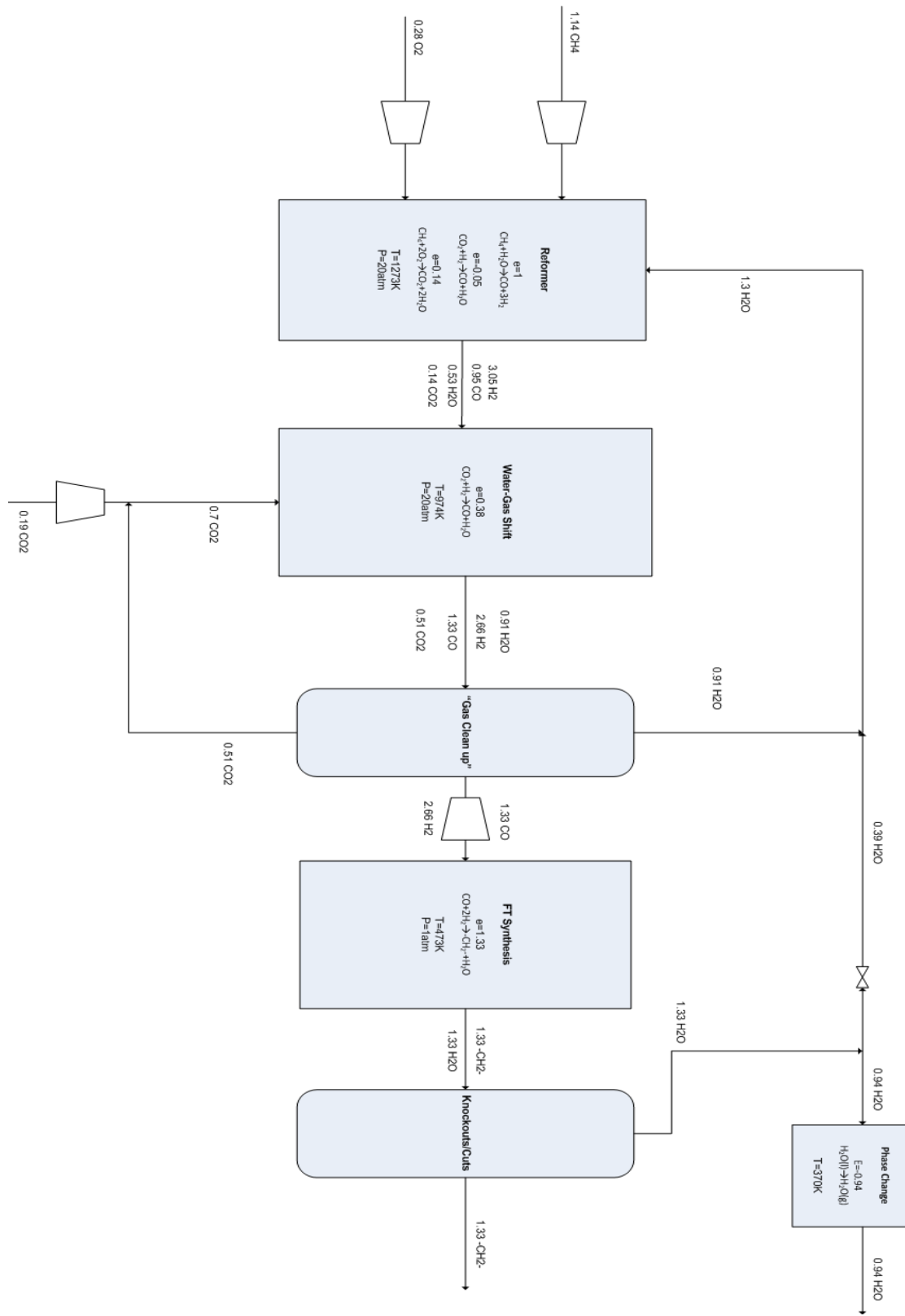

Figure 4.41: Fifth draft process flow sheet including work recovery by increasing the pressure of the syngas production section to 20atm

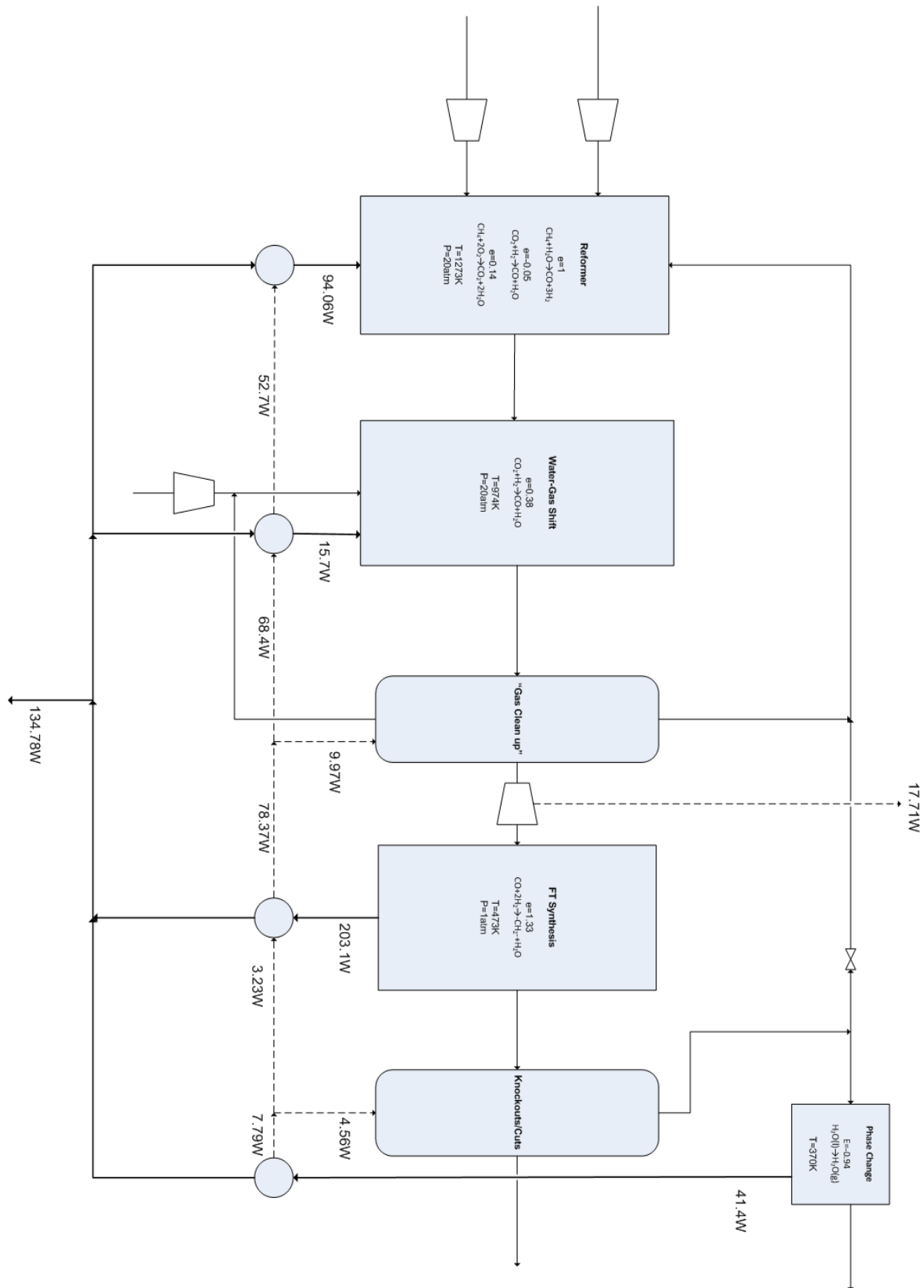

Figure 4.42: Fifth draft flow sheet showing the flows of heat (bold lines) and the flows of work (dashed lines)

The Fifth draft of the process flow sheet (Figure 4.41) produces 17.7 W of power in addition to hydrocarbons and excess water. This shows that, in some cases, having excess work in the process is not necessarily a bad thing. If this work can be recovered as useful real work it can actually be advantageous. It promotes the idea of “co-generation”, in this case the chemical products of hydrocarbons and water as well as electricity.

The limiting factor for this situation would be how high a pressure is needed to recover all the work, if the required pressure is excessively high, complete recovery of work would not be possible.

That does not mean pressure as a means of work recovery should be abandoned if the required pressure is too high. A more reasonable pressure could still be used to recover at least some of the work, which would be preferable to simply losing all the excess work.

The hydrocarbon products could be sold to the national infrastructure or as exports and the electricity could be sold to the power grid or used on-site. One such on-site use of this power would be in the separation of air to produce the needed oxygen for the combustion reaction in the Reformer unit. Air separation is a science unto itself but fortunately the amount of oxygen required is comparatively small.

With the ideal separation model used previously the amount of work required to perform the necessary air separation, assuming 79% N₂ and 21% O₂ in air, can be calculated using Equation [7]. The results of this calculation show that to provide 0.28 mol/s of oxygen to the process, 1.33 mol/s of air is required and 1.7W of work is needed to perform this separation.

The minimum work required for the air separation is less than the total work recovered from the process, so the overall process could still generate electricity if desired.

Air separation is not necessarily required by the process. Air could be fed into the process with nitrogen being treated as an inert. This will have an effect when the time comes to size the process equipment. The inert nitrogen will also have to leave the process somewhere. This implies a separation step somewhere else in the process or some form purge/flare. Another option would be to combust the lightest cuts from the “Knockout/Cuts” section of the process (which would contain the nitrogen) in a gas turbine to generate additional electricity. This is another example of how the GH-space can be applied with ever increasing detail.

However, assuming some form of air separation is used, the Sixth draft of the Process flow sheet can be drawn, Mass flows as Figure 4.43 and heat and work flows as Figure 4.44:

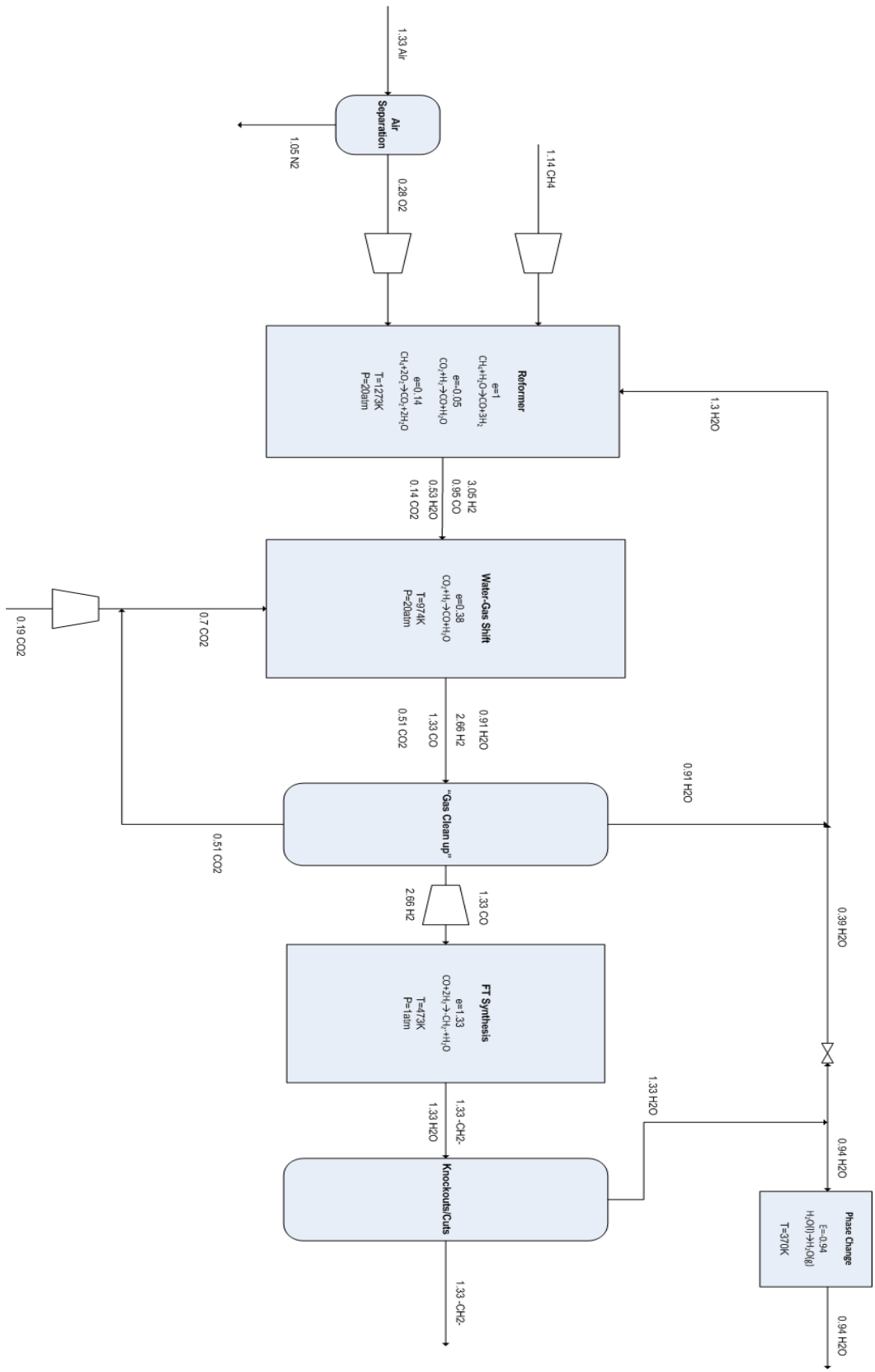

Figure 4.43: Sixth draft flow sheet with air separation

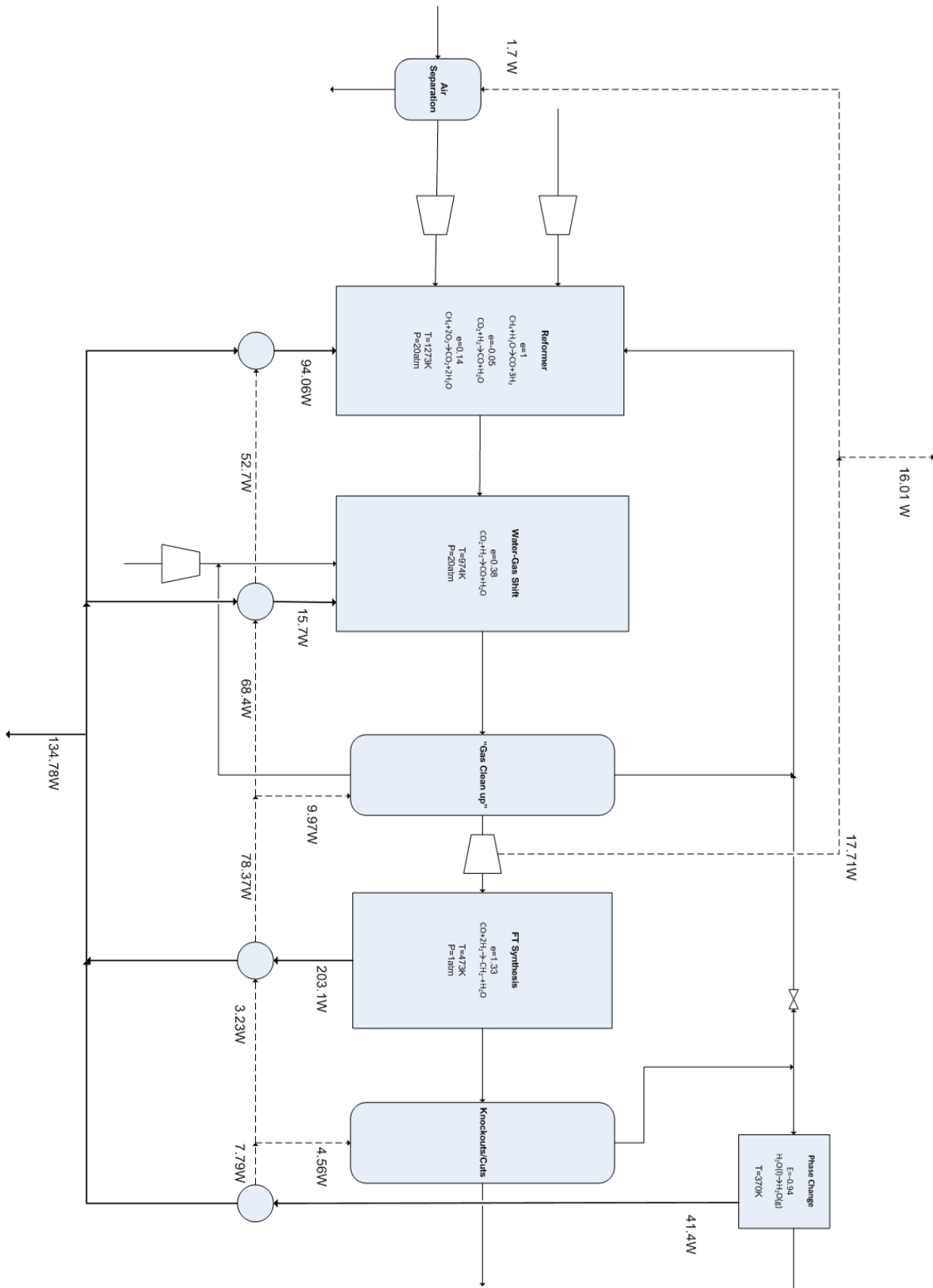

Figure 4.44: Sixth Draft flow sheet showing flows of heat (bold lines) and flows of work (dashed lines)

4.4 Conclusion

In the synthesis of this Fischer-Tropsch process flow sheet the mass, energy and work balances were used to determine the layout of the process. As opposed to the process layout being used to determine the mass, energy and (possibly) work balances.

In doing so the flows of mass, energy and work within the process can be understood and manipulated in such a way as to allow the design of a process that has a high degree of reversibility.

In this synthesis five independent material balances (or reactions) were defined:

- The production of synthesis gas by Steam Reforming
- The combustion of natural gas in oxygen to provide heat and work
- The modification of synthesis gas ratios by Water-gas shift
- The production of $-CH_2-$ hydrocarbons by the FT synthesis reaction
- The production of steam by the phase change of water

By manipulating the extent of each of these reactions, as well as their temperatures, it was possible to determine the overall material balance for the process such that the process would be overall exothermic with no excess work.

The temperature of the Reforming unit was chosen to allow the complete reaction of the methane feed. By setting the temperature of the Combustion reaction to be the same as reforming reaction, the possibility for both reactions being carried out in one unit arose. This provided the first insight into how the GH-space could begin to be related to actual process equipment.

The temperature for the Water-gas shift unit was chosen to be the Carnot temperature for that reaction which allowed all the necessary heat to simultaneously carry the necessary work.

The temperature for the FT reaction was chosen to be in the range of the favored production of the diesel fuel cut size.

By including the work flows for mixing and separation it was found that perfect separation undoes the work of ideal mixing. This resulted in the overall process now containing an excess of work.

By operating the Reforming section of the process at 20 atmospheres pressure the excess work caused by mixing could be recovered as real, useful work. There are a variety of ways in which this work could be utilized with some of it potentially being used for air separation and electricity generation being another.

It is worth noting that the reforming section of this process turned out to be a slightly modified version of the Reforming process designed in a previous paper,²

Utilizing Figure 4.43 the overall material balance for the process could be written as:

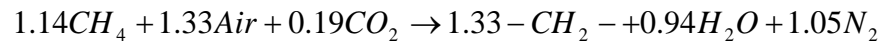

For which the overall energy and work balances are:

$$\Delta H = -134.78 \text{ W}$$

$$\Delta G = -16.01 \text{ W}$$

While these flows are currently very small, at this level of detail all these values can be easily scaled to any desired magnitude.

The important things to note with the above balances are that the process produces hydrocarbon fuels, with water and nitrogen by-products, from natural gas, air and carbon dioxide. This process actually consumes Carbon Dioxide rather than producing it. In addition to this the process can potentially also produce electricity.

The design done in this paper utilized idealized models to synthesize a flow sheet that represents what can be considered to be a “best case” scenario. The GH-space is not limited to idealized models however; any method that can calculate the Enthalpy and Gibbs-Free energy of any unit operation can be used. Data on catalyst activities, etc can also be incorporated into this design methodology.

The GH-space will tend to find the best thermodynamic layout and conditions for any process. The best may not always be attainable in practicality but in understanding what the best is the foundations for understanding what modifications need to be made and why are present.

Current research in the group at the University of the Witwatersrand is attempting to use this technique in the analysis of existing process flow sheets.

The GH-space is a dynamic and flexible synthesis technique that allows designers to apply sound judgment and innovation from the very outset of a design project, providing an understanding of the interaction between individual process units and their contributions to the process as a whole.

References

1. J.A. Fox, D. Hildebrandt, D. Glasser, B. Patel, B. Hausberger, *A Graphical Approach to Improving Gasification*, 2010
2. J.A. Fox, D. Hildebrandt, D. Glasser, B. Patel, *A Graphical Approach to Process Synthesis and its application to Steam Reforming*, 2010
3. Mahalec, V. and Motard, R. L. (1977) Procedures for the Initial Design of Chemical Processing Systems. *Computers and Chemical Engineering*. **1**(1), 57-68
4. Westerberg, A.W. (2004) A Retrospective on Design and Process Synthesis. *Computers and Chemical Engineering*. **28**(4), 447-458
5. Rosen, M. A. and Dincer, I. (2001) Exergy as the confluence of energy, environment and sustainable development. *Exergy, An International Journal*. **1** (1), 3-13
6. El-Halwagi, M.M., *Pollution prevention through Process Integration: Systematic Design Tools*, Academic Press, San Diego (1997)
7. Dunn, R.F. and El-Halwagi, M.M. (2003) Process Integration Technology Review: Background and Applications in the Chemical Process Industry. *J Chem Technol Biotechnol*. **78** (9), 1011-1021
8. Floudas, C. A and Kokossis, A. C. (1990) Optimization of Complex Reactor Networks-I. Isothermal Operation. *Chemical Engineering Science*. **45**(3), 595-614
9. Floudas, C. A. and Kokossis, A. C. (1994) Optimization of Complex Reactor Networks-II. Non-Isothermal Operation. *Chemical Engineering Science*. **49** (7), 1037-1051
10. Floudas, C. A. and Anastasiadis, S.H. (1988) Synthesis of distillation sequences with several multicomponent feed and product streams. *Chemical Engineering Science*. **43**(9), 2407-2419
11. Zhang, L. Linninger, A. Synthesis of complex distillative separation sequence, 2007 Proceedings of AIChE Annual Meeting; Salt Lake City, UT; November 2007; Code 74094
12. Kokossis, A.C. and Briones, V. (1999) Hypertargets: A Conceptual Programming approach for the optimisation of industrial heat exchanger networks-I. Grassroots design and network complexity. *Chemical Engineering Science*. **54** (4), 519-539
13. Kokossis, A.C. and Briones, V. (1999) Hypertargets: A Conceptual Programming approach for the optimisation of industrial heat exchanger networks-II. Retrofit Design. *Chemical Engineering Science*. **54** (4), 541-561

14. Kokossis, A.C. and Briones, V. (1999) Hypertargets: A Conceptual Programming approach for the optimisation of industrial heat exchanger networks-III. Industrial Applications. *Chemical Engineering Science*. **54** (5), 685-706
15. Shadel, B.C., Duisberg, M., Deutschmann, O. (2009) Steam Reforming of Methane, Ethane, Propane, Butane and Natural Gas over a Rhodium based catalyst. *Catalysis Today*. **42** (1-2), 42-51
16. Escritori, J.C., Dantas, S.C., Soares, R.R., Hori, C.E. (2009) Methane Autothermal Reforming on nickel-ceria-zirconia based catalysts. *Catalysis Today*. **10** (7), 1090-1094
17. Wu, P., Li, X., Ji, S., Lang, B., Habimana, F., Li, C. (2009) Steam Reforming of Methane to Hydrogen over Ni-based metal monolith catalysts. *Catalysis Today*. **146** (1-2), 82-86
18. Patel, B., 2007, Fundamental Targets for the synthesis and evaluation of chemical processes. Thesis, (PhD), University of the Witwatersrand
19. Sempuga, B.C., Hausberger, B., Patel, B., Hildebrandt, D., Glasser, D. (2010) Classification of Chemical Processes: A Graphical Approach to Process Synthesis to Improve Reactive Process Work Efficiency. *Ind. Eng. Chem. Res.* **49** (17), 8227-8237
20. Oaki, H. and Ishida, M. (1982) Study of Chemical Process Structures for Process Synthesis. *Journal of Chemical Engineering of Japan*. **15**(1), 51-56
21. Donnelly, T.J. and Satterfield, C.N. (1989) Product Distributions of the Fischer-Tropsch Synthesis on Precipitated Iron Catalysts. *Applied Catalysis*. **52**(1), pp 93-114
22. Kumabe, K., Sato, T., Matsumoto, K., Ishida, Y., Hasegawa, T. (2010) Production of hydrocarbons in Fischer-Tropsch synthesis with Fe-based catalyst: Investigations of primary kerosene yield and carbon material balance. *Fuel*. **85**(8), pp 2088-2095
23. York, A. P. E., Xiao, T., Green, M. L. H. (2003) Brief overview of the partial oxidation of methane to synthesis gas. *Topics in Catalysis*. **22**(3-4), pp 345-358
24. Choudhary, V.R., Mondal, K.C., Choudhary, T.V. (2006) Oxy-CO₂ reforming of methane gas to syngas over CoO_x/MgO/SA-5205 catalyst. *Fuel*. **85**(17-18), pp 2484-2488
25. Horn, R., Williams, K.A., Degenstein, N.J., Bitsch-Larsen, A., Dalle Nogare, D., Tupy, S.A., Schmidt, L.D. (2007) Methane catalytic partial oxidation on autothermal Rh and Pt foam catalysts: Oxidation and reforming zones, transport effects and approach to thermodynamic equilibrium. *Journal of Catalysis*. **249**(2), pp 380-393
26. Li, Y., Wang, Y., Zhang, X., Mi, Z. (2008) Thermodynamic analysis of autothermal and CO₂ reforming of methane. *International Journal of Hydrogen Energy*. **33**(10), pp 2507-2514

5 Overall Conclusions

5.1 Summary of Main Results

In this research the GH-space was used to synthesize flowsheets that had the overall goal of minimizing the carbon emissions as well as minimizing the loss of work that could have been put to use, while also maintaining production capability. The GH-space is a new tool for design that seeks to take advantage of the lower costs but higher flexibility available during the conceptual phases of a design project.

This was done by applying the GH-space concept to the synthesis of processes that have a reputation for having poor performance in regards to carbon dioxide emissions. Specifically, Coal Gasification, Methane Steam Reforming and Fischer-Tropsch hydrocarbon fuels.

This research provided idealized illustrations of how process targets can be met in a process flowsheet developed from mass, energy and work balances. These are not the absolute solutions to the problem of environmental impact but rather a basis where that could begin to be done.

The results summarized below are not intended to be an absolute final solution to the problems of emissions and energy efficiency. These results represent an ideal case; they represent the best case, the “target” for the process. Obviously a real process would never perform as well as the ideal but knowing what the ideal actually is provides a basis for comparison. How far is a design from the ideal? Is it possible or practical to attempt to improve the real case? The ideal solution provides valuable information in answering those questions, amongst others.

The key to the GH-space approach is that all unit processes can be represented as vectors on the GH-space if their Enthalpy and Gibbs free energies can be defined. This also allows any number of unit processes to be represented on a single set of two dimensional axes.

The GH-space provides the means where flowsheets can be constructed from the mass, energy and work balances rather than these balances been done upon a finalized layout. This allows processes to be designed from the ground up that can meet their desired targets on an integrated “systems wide” level rather than on the unit process level.

For all the strengths of the GH-space, the technique is not without its weaknesses. As a thermodynamic tool, the GH-space gives little to no information in regards to kinetics and catalysis. Additionally the GH-space cannot handle the heat exchanger unit, this is not a weakness of the technique precisely but rather where the current research is situated. Dealing with heat exchangers will require additional research and development of the technique. This is work that is currently underway.

5.1.1 Coal Gasification

Work began with the synthesis of a Coal Gasification flowsheet. The analysis showed Coal Gasification was a process limited by heat rather than work, which meant that the best thermodynamic target for a Coal Gasification flowsheet was for the overall process to be adiabatic with excess work. The overall material balance for a process which met that target was:

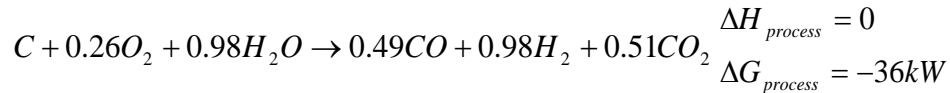

The carbon efficiency for this flowsheet is fairly low at 49%. In addition to that low carbon efficiency it was shown that, even under the most extreme operating conditions, all of the excess work could not be recovered.

This means that, in regards to using coal as a means to produce synthesis gas, there will always be a price to pay. No Coal Gasification process could ever be run without carbon emissions or loss of work potential, even under ideal conditions. The use of coal is probably not a matter of preference but a matter of availability.

5.1.2 Methane Steam Reforming

The next step in the research was to attempt to use an alternative feed material to determine if it was possible to produce synthesis gas with minimum carbon emissions. The obvious choice was the use of natural gas.

Much like the case of Coal Gasification it was found that the best thermodynamic target for the process was an overall adiabatic process with excess work that had the potential to be recovered as useful work. There was only one process material balance that could satisfy all of the design targets:

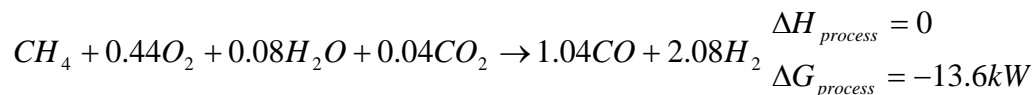

The conditions of the process were carefully chosen to reach two important objectives. Firstly, to ensure there would be no un-reacted methane (complete reaction of methane). Secondly, to ensure that there was sufficient Water-gas shift reaction to attain the desired ratio in the synthesis gas product.

This flowsheet had a carbon efficiency of 104%. This meant that the process actually used carbon dioxide as a feed material. In addition to this the excess work of the process could all be recovered as useful power, using an integrated compressor/turbine system that operated at a pressure of 7.2 atmospheres.

This positive result showed that a Methane Steam Reforming process could not only be run with no carbon emissions but also create power as a co-product. This in turn leads into the idea of “co-production”. This is a comparatively new idea in industry where valuable side can be produced alongside the processes primary product.

5.1.3 Comparison of Coal Gasification and Methane Steam Reforming

It was clear from the previous results that Methane Steam Reforming allowed for the design of a process with better carbon and work efficiency. One reason for this is immediately obvious from the overall material balances of the two different processes. Methane has hydrogen in its molecular structure while coal (which is considered to be carbon) does not. This means that Coal Gasification produces a syngas product that is comparatively lean in hydrogen, while Methane Reforming produces a syngas product that

is comparatively rich in hydrogen. From the material balances alone it can be seen that Methane is the preferred feedstock for syngas production.

Further evidence of this can be seen in the recovery of the excess work and in the operating conditions of the two processes. For Coal Gasification, even at very extreme operating conditions (2000°C and 75atm) at most 82% of the total excess work of the process could be recovered as power. For the Methane Steam Reforming, all the total excess work could be recovered from the process at far milder process conditions.

It is clear that, given the choice, using natural gas to produce syngas is preferred. Naturally there is not always a choice as there can be many other factors influencing the use of coal or natural gas; such as the quantity available, the ease of availability, etc.

In most cases the production of syngas is the first step in a larger process, where the syngas is typically used to produce higher value products like hydrocarbon fuels and methanol. The next step in this research is to apply the GH-space to the synthesis of a flowsheet that produces hydrocarbon fuels via Fischer-Tropsch synthesis using natural gas as the carbon feedstock.

Another consideration is that Gasifiers and Methane Reformers sometimes have problems with carbon deposition. The GH-space is a thermodynamic analysis; thermodynamics does not predict the deposition of carbon. Carbon deposition appears to be primarily a kinetic issue, linked especially to the use of Nickel catalysts. The most used method of avoiding carbon deposition is to ensure an excess supply of water fed to the Reformer/Gasifier. This water to methane/coal ratio can be set by the designer to be any desired value and used in the GH-space. It was shown in the work on Steam Reforming that having excess water is actually useful to ensure full conversion of the methane feed. To clarify, carbon deposition is a kinetic issue that is not predicted thermodynamically but consideration can be given to it using other means such as ensuring an excess water feed.

5.1.4 Design of Fischer-Tropsch fuels using Methane Steam Reforming

The production of synthesis gas is normally only the first step in a larger process, the syngas produced in this first step is then used to produce a variety of products, including hydrocarbon fuels and alcohols. These large processes have a reputation for being some of the largest point sources of carbon dioxide emissions in the world. The question then became, is this an unavoidable limitation of such processes or is it possible to design them with less emissions?

From the results of the previous two flowsheets it was decided that Methane Steam Reforming would be used in the next design.

The best thermodynamic target for a Fischer-Tropsch process was found to be an overall exothermic process with no excess work. The only material balance that could satisfy this target was:

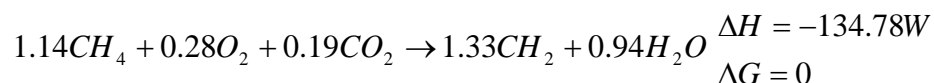

The carbon efficiency of this process is 117%. The addition of Fischer-Tropsch synthesis has had the effect of actually improving the carbon efficiency of the methane steam reforming plant by 13%. The

Fischer-Tropsch synthesis reaction is itself exothermic, by using the heat released by this reaction to supply the energy needs of the rest of the process results in less energy being required from combustion. With less combustion needed, the process produces less of its own CO₂ which in turn increases the amount of CO₂ that must come from outside the process and thus increasing the carbon efficiency.

It is thermodynamically possible to create a Fischer-Tropsch process that has no carbon dioxide emissions. Why do existing process have such significant emissions? One major reason is the existing practice of choosing process conditions to match catalyst operation, as opposed to designing a catalyst to match preferred process conditions. Designing a catalyst to match the process is not normally the way things are done but it is a different approach to attempt to deal with new problems facing engineering. Another issue may arise in that existing processes tend to perform more combustion than necessary, this is apparently done as a type of energy “safety net” following the idiom of “better to have and not need than to need and not have”. Careful control of the highly irreversible combustion reactions is needed.

For an ideal flowsheet that produced only pure components the mass, energy and work balances worked very well. However upon consideration of the effects of mixing and separation it was found that there would be an excess work, the balances above would have become:

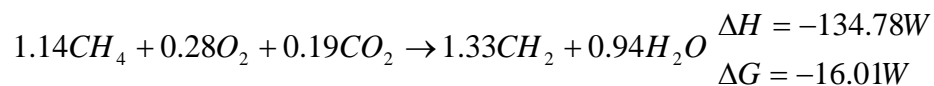

There are a number of ways to deal with this new excess work. This illustrates one of the most important results of the GH-space methodology; it allows a designer to apply great innovation from the earliest stages of design.

One way to solve this excess work problem is to change the material balance such that the excess Gibbs free energy returns to zero. The subtle implication of making that change is that the work of mixing is somehow harnessed by the process. The simplest way this might be done is if the work of mixing flowed into the next process unit with the mass. Another method might be some form of solvent extraction where the work of mixing is used to facilitate a separation. Both of these have strong practical implications and there are likely countless other approaches to harnessing work of mixing.

Another method of solving the excess work problem is to leave the mass, energy and work balances unchanged but to actually recover the excess work as power. It had been shown in the Methane Steam Reforming flowsheet that work could be recovered from the syngas production section using an integrated compressor/turbine system. It was found that by operating the Reforming section of the process at 20 atmospheres the excess work could be recovered from the process as power. It is interesting to note that this has the effect of making the syngas section, of the Fischer-Tropsch process, take a similar appearance to the Methane Steam Reforming process previously designed, albeit with slightly modified conditions. This shows that a stage-wise design of a process flowsheet could be performed using the GH-space and the individual sections could then be fit together, making necessary modifications to operating conditions.

The GH-space is a versatile tool that can handle as much complexity as is desired by the designer. As long as the mass, energy and work balances of a process unit can be defined they can be analyzed with the GH-space.

The goal of this work was to investigate if it was possible to design process flowsheets that minimized the losses of work and the emissions of carbon dioxide while also maintaining process productivity. The GH-space showed that not only is it possible to design carbon neutral processes but it is possible to design carbon consuming processes, as well as being possible to recover power from these carbon consuming processes. In some cases there will always be a price to pay but it is entirely possible to minimize this price. If one cannot eliminate emissions and losses, then make the best use of what you must emit.

5.2 Recommendations

An area of some interest has been the hybridization of the feed of Fischer-Tropsch processes to be some combination of coal and methane. While this idea was not explored in detail herein some insights can be gained from the results of this research.

It was shown that the use of coal will always have comparatively poor carbon efficiency. Any amount of hybridization with methane will cause a decrease in the carbon efficiency, becoming carbon neutral at some ratio of coal to methane and then beginning to emit carbon dioxide as more coal is used. Using any amount of coal will also increase the excess work in the process to a point where it will no longer be possible to recover all of it. However by using at least some coal allows for the use of a cheaper, easily available feedstock.

Another area of interest is the use of biomass and some form of hybrid biomass feed. Research on this is currently underway.

Other research currently underway is a continuation of this work, which is to attempting to use to GH-space to analyze existing flowsheets to determine where the losses occur and how existing processes might be retro-fitted to minimize these losses.

The next step from there is to move to more detailed design using the GH-space. While this work made brief mention of specific process equipment (the use of Auto-thermal Reformers) there is still much more detail to be investigated.

Another avenue of further research is to develop algorithms for the use of the GH-space that can be programmed into a computer model. The caveat here is that excluding the human element too much from the use of the GH-space has the danger of removing what is perhaps the greatest advantage of the method, the room for constant innovation.