

**STABILITY OF STAINLESS STEEL (SS), COBALT-  
CROME (CO/CR) AND  $\beta$ -TITANIUM LINGUAL  
ARCHWIRES**

---

Elena L Cheshankova-Kostova

A research report submitted to the Faculty of Health Sciences, University of the Witwatersrand, Johannesburg, in partial fulfilment of the requirements for the degree of Master of Science in Dentistry.

I hereby declare that this is my own work, and that it has not been submitted or incorporated in any other dissertation or thesis for any other degree.

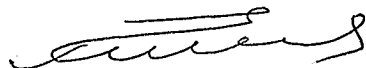

Elena L Cheshankova-Kostova

-----14-----day of June-----1999.

## ABSTRACT

This study investigated the stability of archwires used as lower lingual retainers in orthodontics.

Straight 90 mm lengths of SS, Co/Cr (*Elgiloy* "blue") of 0.036" and 0.040" diameter and  $\beta$ -Titanium (TMA) of 0.036" orthodontic wires were bent into a standard lingual arch form. The SS was heat-treated at 900° F for 10 minutes and the Co/Cr at 1200° F for five minutes in a dental furnace. The  $\beta$ -Titanium and the SS and Co/Cr control groups were not heat-treated. Arch widths were measured immediately after heat-treatment, at four and at eight weeks later.

Heat-treatment produced an immediate expansion, especially in the SS (0.036" by 4.91 mm; 0.040" by 4.19 mm). Little change was recorded thereafter, with *Elgiloy* 0.036" and 0.040" being the most stable.

When the arches which had not been heat-treated were measured the *Elgiloy* 0.036" recorded the greatest change (0.853 mm) after eight weeks.

The forces generated when the expanded arches were compressed to their original contour were of rather small levels. The 0.036" *Elgiloy* offered the greatest force (14.0102 grams). The remaining arches recorded force levels ranging from 3.0612 grams to 11.0918 grams. Statistical analyses included an Anova test which revealed statistical significance for several of the changes at a probability level of 0.0001. However, the quanta of the forces generated were of levels unlikely to have any clinical impact.

The experiment indicated that heat-treating wires used for lingual arches was probably not indicated in the clinical application.

## ACKNOWLEDGEMENTS

I wish to thank my supervisors, Prof. WG Evans and Dr. R Essop, for their guidance in the preparation of this research report.

To Prof. D Chandler I would like to express my gratitude for his generous and valuable assistance with this project.

To Dr. G Shipper and to Department of Restorative Dentistry I wish to record my thanks for the encouragement and assistance.

My sincere thanks are due to my father Lubomir and my husband Edward, for their encouragement and patience, and it is to them that I dedicate this research report.

## TABLE OF CONTENTS

	<b>Page</b>
Declaration	ii
Abstract	iii
Acknowledgements	iv
Table of Contents	v
List of Figures	vii
List of Tables	viii
CHAPTER 1.0 Introduction and Literature Review	1
1.1 Lower Lingual Arch Space Maintainer	1
1.2 Useful Materials and Sizes for Lower Lingual Arch Space Wires	3
1.3 Heat Treatment	8
1.4 Application of Lower Lingual Arch Space Maintainer	12
1.6 Study Objectives	13
CHAPTER 2.0 Materials and Methods	15
2.1 Preliminary Survey	15
2.2 Materials	16
2.3. Methodology	17
2.4 Statistical Analysis	24
CHAPTER 3.0 Results	26
3.1 Error of the Method	26
3.2 Expansion due to Heat Treatment	27
3.3 Expansion of Control Archwires	27
3.4 Expansion of Experimental (Heat-treated) Archwires	28

	<b>Page</b>
3.5 Comparison of Heat-treated and Non-heat-treated Archwires of the same Material and Size	30
3.6. Comparison of Archwires of Differing Materials and Sizes	31
3.6.1 Heat-treated Wires	31
3.6.2 Non heat-treated Wires	31
3.7 Forces Generated as a Result of the Expansion of the Control Groups	33
CHAPTER 4.0 Discussion	42
4.1 Could the performance of the wire be improved by heat-treatment? Would different materials and sizes react in similar fashion after being heat-treated?	44
4.2 Could orthodontic wires confidently be used for fabrication of space maintainers without heat-treatment?	46
4.3 Would the dimensional change of the non-heat-treated wire be such that actual tooth movement could occur?	46
4.4 Would the wire material and size determine the stability of the archwire and if so would this be clinically significant?	48
CHAPTER 6.0 Conclusions	49
CHAPTER 7.0 References	50

## LIST OF FIGURES

Figure	Page
Figure 1.1: Influence of heat treatment on strength, resilience and formability	11
Figure 2.1: Jig for bending of archwires	18
Figure 2.2: A group of 20 samples (archwires)	18
Figure 2.3: SIP Universal Measuring Machine	20
Figure 2.4: Plastic jig for accurate positioning of the samples in the SIP Universal Measuring Machine	20
Figure 2.5: JJ Lloyd Tensile Tester	22
Figure 2.6: Jig for securing the archwire into the Tensile Tester- <i>first component</i>	22
Figure 2.7: Jig for securing the archwire into the Tensile Tester- <i>second component</i>	23
Figure 2.8: Jig for securing the archwire into the Tensile Tester- <i>first &amp; second components</i>	23
Figure 2.9: Position of the archwire during compression	25
Figure 2.10: Computer generated graph illustrating the compression force	25
Figure 3.1: Mean expansion immediately after heat treatment	38
Figure 3.2: Expansion of SS 0.036" archwires immediately after heat treatment	38
Figure 3.3: Expansion of SS 0.040" archwires immediately after heat treatment	39
Figure 3.4: Expansion of <i>Elgiloy</i> 0.040" archwires immediately after heat treatment	39
Figure 3.5: Expansion of <i>Elgiloy</i> 0.036" archwires immediately after heat treatment	40
Figure 3.6: Mean expansion of the non-heat-treated archwires at the 8 <sup>th</sup> week	40
Figure 3.7: Mean expansion of heat-treated archwires at the 8 <sup>th</sup> week	41
Figure 3.8: Mean force in grams required to compress the archwires back to the original shape	41

## LIST OF TABLES

<b>Table</b>	<b>Page</b>
Table 3.1: Expansion of the experimental archwires in mm immediately after heat-treatment	34
Table 3.2; Mean expansion in mm of the archwires at the 4 <sup>th</sup> week	35
Table 3.3: Mean expansion in mm of the archwires between 4 <sup>th</sup> and 8 <sup>th</sup> week	35
Table 3.4: Mean expansion in mm of the archwires at the 8 <sup>th</sup> week	36
Table 3.5: Force in N required to compress the archwires back to the original shape	37

## CHAPTER 1

### 1.0 INTRODUCTION AND LITERATURE REVIEW

Lingual arches have long been used either as the sole method of treatment or as adjuncts to other orthodontic appliances. The arch consists of a wire bent to the shape of the lingual contour of the lower dental arcade and usually is attached by solder to metal bands fitted around the lower first permanent molars. The wire should be at least 1.5 mm away from the soft tissue in the buccal segments and should allow sufficient space for the eruption of teeth. Anteriorly the wire lies in contact with the lingual surfaces of the lower incisors above the level of the gingivae. Adjustment 'U' loops may be incorporated mesial to the permanent first molar (Hitchcock, 1).

The functions of the lingual arch are to preserve the lower arch perimeter, act as an anchorage device or allow active tooth movement with reciprocal or asymmetric mechanics. It offers variety of control which is difficult to accomplish with buccal wires (Burstone & Manhartberger, 2).

#### **1.1 Lower Lingual Arch Space Maintainer**

As the occlusion develops from the primary dentition through the mixed dentition to the permanent dentition a sequence of co-ordinated events normally results in a functional, aesthetic and stable occlusion. An intact primary arch plays an important role in speech, mastication, aesthetics, prevention of oral habits, and in guiding the erupting permanent teeth (Moyer, 3). Ectopic eruption, congenital disorders, caries and its sequelae and trauma can cause the loss of primary teeth, which may influence any of these functions (Ghafari, 4). Premature loss of primary teeth often leads to undesirable drifting of the adjacent teeth,

thereby reducing the arch space available to the succeeding dentition. Such space deficiency can produce or exacerbate a malocclusion, causing complications such as crowded, rotated, or impacted permanent teeth. Indeed, malalignment usually is the consequence of a lack of sufficient dental arch perimeter between the first permanent molars to permit satisfactory alignment of the erupting permanent teeth. Whilst the dimensions of dental arch perimeter *per se* may depend on many additional factors, such as the timing and sequence of eruption of permanent teeth, intercuspatation, muscular forces, and forces involved in craniofacial growth (Ghafari, 4), nevertheless loss of space is a crucial influence.

Hence space maintenance is an integral part of Preventive Orthodontics and has always posed a challenge to the dentist. Space maintenance can be defined as the preservation of spaces left by premature loss of primary incisors, primary canines, primary molars, and sometimes the primate spaces (Ghafari, 4). Space maintaining appliances may be used to prevent or reduce the severity of tooth migration, arch space reduction, and malocclusion in the permanent dentition following the premature loss of primary teeth.

According to Moyer (5) space maintenance is indicated only when the following conditions are concurrently present: 1) the loss of one or more primary teeth, 2) no loss of arch perimeter, and 3) a favourable Mixed Dentition Analysis prediction. The distinction between a **space maintainer** and a **space regaining** appliance is that the former is passive and the latter is active.

Some authors (Ghafari, 4; Woodward & Leake, 6) offer the directive that a space maintainer should not be placed if: 1) cuspal interdigitation will prevent tooth migration; 2) inter-dental spacing is present; 3) the succedaneous tooth will erupt within six months; or 4) arch space analysis indicates that the existing space problem is so severe that malocclusion is any event likely.

The lower lingual arch is a commonly used space maintaining appliance, designed to stabilise arch perimeter by preventing mesial tipping or migration of the mandibular molars (Rebellato,

*et al*, 7), especially after exfoliation of the lower second deciduous molars. The appliance prevents subsequent loss of arch length occurring in the normal transition from the late mixed dentition to the early permanent dentition (Proffit, 8) and is often recommended after the loss of multiple primary teeth in the mandibular arch (McDonald, Hennon & Avery, 10). Singer (9) pointed out that the lingual arch space maintainer braces the molar position against the mandibular incisors, which also prevents the incisors from tipping lingually.

## 1.2 Useful Materials and Sizes for Lower Lingual Arch Wires

Success in orthodontic treatment with lingual arch space maintainers is largely dependent on the stability of the wires in retaining a specific shape. The knowledge of the physical and mechanical properties of orthodontic wires may influence the selection of wire size and alloy type improving the predictability results.

Desirable characteristics and properties of orthodontic wires contributing to optimum performance during treatment are as follows (Goldberg & Burstone, 11; Andreasen & Morrow, 12; Burstone & Goldberg, 13).

- (1) **High stiffness or high load deflection rate.** This determines the magnitude of the force delivered by a spring wire appliance and is proportional to the modulus of elasticity of the wire. In terms of the lingual arch this is the resistance to bending. It is the property that makes it useful in this application.
- (2) **Joinability.** Capacity to be soldered to auxiliaries and attachments. This property provides an additional advantage when incorporating accessories to the appliance.
- (3) **Good springback.** This is referred to as maximum elastic deflection, maximum flexibility, range of activation, range of deflection, or working range. Springback is related to the ratio of yield strength to the modulus of elasticity of the material.

- (4) **High formability.** This is the ability of the material to undergo changes in shape to a required configuration without fracture.
- (5) **Biocompatibility and environmental stability.** Biocompatibility includes both a resistance to intra-oral corrosion and a tolerance of the oral tissues to elements in the wire. Environmental stability describes the maintenance of desirable properties of the wire for extended periods of time after manufacture, particularly in the intraoral milieu.
- (6) **Modulus of resilience or stored energy.** This property represents the work available to apply forces, which may be used to move teeth.
- (7) **Friction.** This is the relative motion between two surfaces. The preferred wire material for moving a tooth relative to the wire would be one that produces the least amount of friction at the bracket/wire interface.

A wire selected for the fabrication of lower lingual arch space maintainers would most advantageously possess these qualities: high stiffness, joinability, formability, biocompatibility and environmental stability.

According to Proffit (14) there are three major properties of beam materials, which are critical in defining their clinical usefulness for orthodontic purposes, viz.: stiffness, strength and range. **Strength** is the force required to activate an archwire a specific distance. **Range** is defined as the distance that the wire will bend elastically before permanent deformation occurs (Proffit, 14). **Stiffness** is the resistance to bending.

$$\text{Strength} = \text{Stiffness} \times \text{Range}$$

Each of these major elastic properties is substantially affected by a change in the geometry of a beam. Both the cross section (whether the beam is circular, rectangular, or square) and the length of a beam are of importance in determining its properties (Proffit, 14). Changing the diameter of a beam has considerable influence. When the diameter of a round wire is doubled, its strength increases eight times ( $\text{strength} \propto d^3$ ), while the springback decreases by a

factor of 16 (stiffness  $\propto 1/d^4$ ) and the range, by a factor of two (range  $\propto 1/d$ ) (Proffit, 14). As the diameter increases the wire stiffness increases so rapidly that a point is soon reached at which the wire is simply too stiff to be clinically valuable (Proffit, 14).

Useful wire materials and sizes advocated by Proffit (14) for lingual arches are: gold round wire- 0.040" diameter, stainless steel (SS) round wire- 0.030" and 0.036" diameter, cobalt/chrome (Co/Cr) (*Elgiloy*) round wire- 0.030" and 0.036" diameter and  $\beta$ -titanium ( $\beta$ -Ti) 0.036" diameter. Adams (15) recommended 0.040" diameter round stainless steel wire but that was prior to the introduction of some of the newer alloys now available to orthodontists.

Stainless steel was introduced as an orthodontic wire in 1929 and shortly afterward gained popularity over gold. Stainless steel alloys include a wide range of compositions and physical properties. A martensitic stainless steel is primarily an alloy of iron, chromium and carbon and contains little or no nickel. This metal is very hard but is of no use in clinical orthodontics. Austenitic stainless steel is the most commonly used stainless steel alloy and consists of a face centred lattice formation (the centre iron atoms are positioned on the surface of the crystal lattice). It contains about 18% chrome, 8% nickel, and less than 0.2% C and thus known as 18-8 steel. The nickel has a stabilising effect on austenite enabling the material to maintain its structure even at room temperatures. Carbon content was purposely maintained below 0.2% to reduce the formation of chromium carbides, compounds that can hasten the corrosion of austenitic steel. Carbon interstitial hardening and cold working contribute to the high yield strength and modulus of elasticity of stainless steel. The addition of other elements can influence the characteristics of the material to varying degrees. For example cobalt and molybdenum provide the opportunity for considerable versatility in orthodontic wires, as may be evidenced in the consideration of *Elgiloy* and TMA wires.

Cobalt-chromium alloy (*Elgiloy*) consists of Co-40%, Cr-20%, Ni-15%, Fe-16%, and Mo-7%. *Elgiloy* is manufactured in four different tempers as a result of a variety of processes of heating and quenching. The wire is marketed as soft (blue), ductile (yellow), semiresilient (green), and resilient (red). Blue *Elgiloy* is recommended for use when considerable bending, soldering, or welding is required. It can be bent easily and heat treatment increases its resilience to any further deformation (Asgharnia & Brantley, 16). Yellow *Elgiloy* is relatively ductile and more resilient than blue *Elgiloy*. Further increase in its resilience can be achieved by heat treatment. Green *Elgiloy* is more resilient than yellow and can still be shaped with pliers before heat treatment. The fact that it cannot be welded is its biggest disadvantage. The most resilient *Elgiloy* is marked red and provides high spring qualities. This wire does not allow welding and can withstand only minimal working. Heat treatment makes red *Elgiloy* extremely resilient. Since this wire fractures easily after heat treatment, all adjustments should be made before this process (Kapila & Sachdeva, 17).

Goldberg and Burstone (11) first reported on the application of  $\beta$ -Titanium alloy in archwire fabrication in 1979.  $\beta$ -Titanium is commercially available as 'TMA' wire (titanium-molybdenum alloy), having the formula Ti-79%, Mo-11%, Zr-6%, and Tn-4%. It has an excellent balance of properties, with a modulus of elasticity less than that of SS and about twice that of Nitinol (Larson, Kusy & Whitley, 18).

Stainless steel, cobalt-chromium and  $\beta$ -Titanium alloys have remained popular since their introduction to orthodontics.

Each has specific, mostly desirable properties, summarised by Kapila & Sachdeva (17).

- (1) SS-- stiffness-high; springback-low; formability-good; biocompatibility-good; joinability-solderable, and weldable; friction-low, stored energy-low.
- (2) Co/Cr--stiffness-high, springback-low; formability-good; biocompatibility-good; joinability-solderable (with some difficulties), weldable (blue and yellow *Elgiloy* only); friction-low-moderate; stored energy-low.
- (3)  $\beta$ -Ti--stiffness-average; springback-average; formability-good; biocompatibility-good; joinability-solderable; friction-high; stored energy-average.

Perhaps the most important characteristic for a passive lingual arch may be the stiffness of the wire and the associated stability.

It is evident that the metallurgy of orthodontic wires is complex, and that a considerable number of characteristics influence the choice of wires for specific treatment purposes.

Burstone & Koenig (19) formulated a concept stating that the overall stiffness of an orthodontic appliance (S) is determined by the wire stiffness (Ws) and design stiffness (As).

$$S = W_s \times A_s$$

Design stiffness is dependent on factors such as the incorporation of loops and coils into the wire. The wire stiffness depends on cross-section stiffness (Cs) and material stiffness (Ms) according to the formula:

$$W_s = M_s \times C_s$$

An increase in appliance stiffness (S) can be achieved by change in appliance design, an increase in cross-sectional thickness of the wire and by selecting a material with a higher modulus of elasticity (Young's modulus  $E = \text{stress/strain ratio}$ ).

The relationship of the material stiffness values for stainless steel, cobalt chrome and  $\beta$ -Titanium are in the ratio of 1:1.2:0.42 (Kapila & Sachdeva, 17). On that basis the Co/Cr wires may have the advantage in the construction of appliances where stability is desirable.

### 1.3 Heat Treatment

Work-hardening is the result of forced interlocking of grains and atoms of the metal. Many of these grains are locked in situations in which the material is locally under stress, even when the piece as a whole is not stressed. Microscopic regions are under tension or pressure, working against one another.

Heat treatment is used to relieve stresses that otherwise remain locked in a structure as a consequence of a manufacturing sequence. Stress relief heat treating is the uniform heating of a structure or a portion thereof to a suitable temperature below the transformation range, holding the material at this temperature for a predetermined period of time, followed by uniform cooling. This is a level of heat treatment at which internal stresses are relieved by minute readjustments in intergranular relations, but without the loss of hardening that accompanies the higher temperature process of annealing.

A wire that is bent to a form of an arch is replete with residual stresses that tend slowly to return it toward its original form. A stress relieving heat treatment results in an immediate acceleration of this change in shape so that the final form of the wire will be more stable (Thurrow, 20).

The relief of residual stresses is a time/temperature-related phenomenon, parametrically correlated by the Larson-Miller equation:

Thermal effect =  $T(\log t + 20)(10^{-3})$ , where T is temperature and t is hours.

There is an apparent variation in opinion in the literature concerning the ideal temperatures for the heat treatment of orthodontic wires.

Stress relief tests of types 302 and 316 stainless steel (SS) orthodontic wires showed that generally much less than half of the residual stress was removed in the range of the conventional heat treatment (700 to 900 degrees Fahrenheit (F) for 5-15 minutes) (Howe, Greener & Crimmins, 21). Optimum mechanical properties for SS wires were achieved after heat treatment at 900° F for 10 minutes according to Khier, Brantley and Fournelle (22).

Marcotte (23), recommended stress-relieving stainless steel at 399° C (755° F) for eleven minutes in a dental oven.

In 1986 Durr, Vargas & Ward (24) investigated the stress-relief of Co/Cr orthodontic wires, bent into an arch form, by exposing samples to a 950° F temperature attained by three different processes: in a dental oven; by the electric current generated from an orthodontic spot welder; by flame from a dental soldering unit. The test demonstrated that almost all of the dimensional changes in the experimental group took place during the actual procedure of stress-relief. The units were measured immediately after heat treatment, and then three days, and one, two, and four weeks after bending. The width increase of the flame treated group was larger than the changes in the other groups.

Thurrow (20) commented that although heat treatment of orthodontic wires may be performed using different mediums, an oven is the most reliable because of the relatively uniform temperature.

The maximum resistance to permanent deformation of Co/Cr alloy (*Elgiloy*), according to Fillmore & Tomlinson (25), occurs after heat treatment for 5 minutes in the temperature range of 1100° to 1200° F (650° C) in a dental furnace.

A detailed description of the metallurgy and manipulation of  $\beta$ -Titanium, was published by Goldberg and Burnstone (11) who introduced the wire into orthodontic use. No recommendation for heat treatment was mentioned.

Metallic orthodontic devices release metals in the presence of electrolyte (Gjerdet, 26). Metal corrosion may influence both the mechanical behaviour and the appearance of the appliance (Gjerdet, 26). The dimensional stability of SS is improved by heat treatment at 900° F (482° C) for 10 minutes (Khier *et al.*, 22). The study of Gjerdet (26) however, indicated that this type of heat treatment enhanced corrosion and recommended instead temperatures below 400° C. Maximum strength of Co/Cr wires has been found after heating at 1200° F (649° C) for 5

minutes (Fillmore & Tomlinson, 25). The results of Gjerdet (26) however, showed that the temperature should be kept below 500° C to avoid increased release of metals. Co/Cr wires appeared to be more temperature-resistant than SS.

The Co/Cr and SS wires owe their corrosion resistance to passivating chromium oxide layers (Gjerdet, 27). When SS alloys are heat treated above 500° C the chromium oxide layer may spall (fracture in small pieces) on cooling (Howes, 28). Furthermore during high temperature oxidation the underlying zone of alloy will become depleted in chromium, thus making the alloy prone to corrosion. Moreover the SS may lose corrosion resistance owing to intergranular corrosion caused by formation of chromium carbides at the grain boundaries during the heat treatment (von Fraunhofer, 29).

Hazel *et al* (30) conducted a study to determine the force relaxation in orthodontic arch wires. An apparatus was designed to accurately measure over a period of time the variation of forces produced by a representative orthodontic arch wire appliance. Measurements of the force relaxation were made in stainless steel, *Elgiloy*, and nitinol wires at 21 degrees C and 37 degrees C. A wide variation in the rates of force relaxation was observed in the wires tested. The stainless steel wires (0.016" diameter produced by Wilcock in Australia) relaxed less than *Elgiloy* wires. The effect of heat treatment is to reduce the rate of relaxation subsequent to any stress relieving effect. A heat treatment performed on green *Elgiloy* eliminated relaxation altogether and had a significant but lesser effect on blue *Elgiloy*.

Chrome-cobalt (*Elgiloy*) differs from stainless steel in that heat treatment can produce a much greater change in spring properties than the stress relief of stainless steel (Thurow, 20).

The influence of heat treatment on the ultimate strength, the resilience and the formability of four Co/Cr alloys was graphically illustrated by Kusy (31) (Fig 1.1). The four Co/Cr wires

vary in initial formability from a hard and resilient-high spring temper alloy "red", to soft and formable alloy "blue".

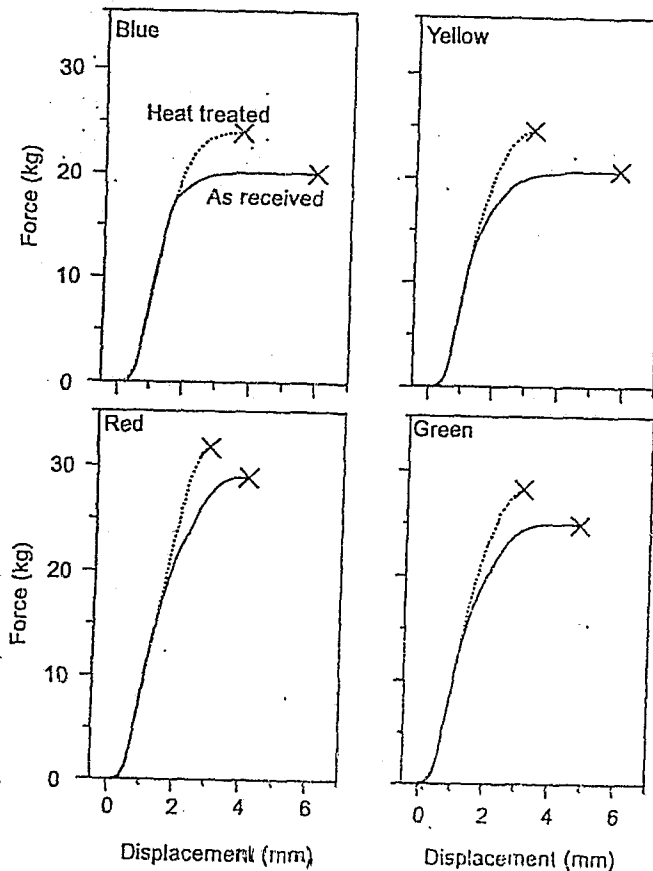

Fig 1.1: Influence of heat treatment on strength, resilience and formability (Kusy, 31)

Lingual arches, of course, are constructed of wires of diameter greater than 0.16" and some investigators have reported on the behaviour of these larger wires. Adams (15), Hitchcock (32) and Proffit (9) recommend heat treating lingual arches. Nagatani, Fisher & Hondrum (33) recorded the effect of heat treatment on 0.036" diameter SS wire bent to the shape of a

lower lingual arch. Their results showed that heat treatment caused immediate and significant expansion ( $p < 0.001$ ) followed by stabilisation of arch width. The control (non heat-treated) wires continued to expand throughout the eight-week study. The forces generated by the expansion in both the control group (273.4 grams) and the experimental group (35 grams) were reported as being capable of producing tooth movement.

The decisions of the operator in terms of wire choice and how it is manipulated may therefore markedly affect the stability of lingual archwires.

#### **1.4 Application of Lower Lingual Arch Space Maintainers**

It has been suggested that a lingual arch maintains arch perimeter, but that this occurs by labial movement of lower incisor as the molars nevertheless migrate mesially (Nance, 34). If this did occur, all mandibular teeth would of necessity migrate anteriorly as a unit while arch perimeter is maintained. The work of Björk and Skieller (35), using implants, clearly showed that the upper dentition could migrate with the lower dentition, leaving the interarch dental relationships unchanged. These results lead to the conclusion that the use of a lingual arch in the mixed dentition to alleviate crowding may only alter the presentation of the malocclusion. In other words some lingual arch patients could stay Class II with reduced crowding while other Class II patients left without a lingual arch space maintainer may have more crowded arches, but they may also become Class I.

Rebellato, *et al* (7) conducted a study in order to determine whether the placement of a lingual arch space maintainer has any benefit as an early treatment appliance. The main objectives of the study were defined as follows:

- 1) to investigate whether a lingual arch space maintainer could reduce dental crowding during the normal transition from the mixed to the permanent dentition, and 2) to demonstrate whether it prevents the expected mesial migration of first permanent molars,

or whether this migration still occurs en masse, precipitating increased lower incisor proclination (Rebellato, *et al.*, 7). Their results showed that passive lower lingual arches are effective in reducing any mesial molar migration and consequent loss of arch length occurring in the transition from the late mixed dentition to the early permanent dentition. They also concluded however that this comes at the expense of slight mandibular incisor advancement and tipping, which may or may not be desirable, depending on ultimate treatment goals.

Clearly it is very important that the lower lingual arch when used for a space maintainer is made passive, to prevent undesirable movement of the abutment teeth (McDonald, *et al.*, 10). Active appliances apply an expansive force, which can tip the lower molars buccally, resulting in a posterior crossbite (Nagatani, *et al.*, 33). Heat treatment is generally but not always recommended to eliminate such residual stresses in a wire subsequent to bending (Backofen & Gales, 36) and to yield a desired level of resistance to permanent deformation (Fillmore, *et al.*, 25).

The technician and the clinician are faced with a wide choice of materials and options in the construction and placing of lower lingual arches. Clearly defined guidelines would be of practical value.

### **1.6 Study Objectives**

The primary aim of this study was to compare the stability of heat-treated and non-heat treated wires of differing metallurgical characteristics and of differing diameters, bent to the shape of a lower lingual arch.

A secondary objective was to measure the forces generated as a result of any expansion of the non-heat treated wires, which had occurred after a period of eight weeks.

Specifically could the following questions be answered:

- (1) Could the performance of the wire be improved by heat-treatment?
- (2) Would different wire materials and sizes react in similar fashion after being heat-treated?
- (3) Could orthodontic wires confidently be used for fabrication of space maintainers without heat-treatment?
- (4) Would the dimensional change of a non heat-treated wire be such that actual tooth movement could occur (e.g. buccal tipping of the first molars)?
- (5) Would the wire material and size determine the stability of the archwire and if so would this be clinically significant?

## CHAPTER 2

### 2.0 MATERIALS AND METHODS

It is evident that there may be differing practices amongst dental technicians in the construction of a lower lingual arch. It is also evident that such variations may exert a strong influence on the archwires produced. Hence it was appropriate to establish, which procedures were commonly followed by local technicians.

#### 2.1 Preliminary Survey

Six orthodontic technicians practising in specialist orthodontic laboratories in Gauteng voluntarily completed the following questionnaire on the construction of lower 6-6 lingual arch space maintainers.

- (1) *For how long have you been in practice as an orthodontic technician?*
- (2) *Do you make more than five (more than 10, more than 15) 6-6 lingual arches a month?*
- (3) *Has this remained about the same for the last several years?*
- (4) *What wire is your first choice for lower 6-6 lingual arch?*
- (5) *Have you ever been requested to use alternative wires? If so please specify?*
- (6) *Do you routinely include 'U' loops in the lingual arch?*
- (7) *Do you heat-treat or process the wire in any way? If so please specify.*
- (8) *Do you routinely solder to the molar bands or do you use weldable tubes and inserts?*
- (9) *Are you aware of any difficulties experienced by the clinicians using the lingual arches you have prepared? If so please specify.*

All six technicians replied. Their responses demonstrate some considerable disparity. A summary of the results is listed below:

- Q1.** *The dental technicians had been in practice between 8 and 21 years.*
- Q2.** *Three technicians make between five and ten 6-6 lingual arch space maintainers a month, one makes more than 10 and two make less than 5.*
- Q3.** *This has remained about the same for the last several years.*
- Q4.** *0.030" diameter SS wire-first choice for two dental technicians*

*0.036'' diameter SS wire- first choice for two dental technicians*

*0.040'' diameter SS wire first choice for one dental technician*

*0.028'' diameter SS wire first choice for one dental technician*

**Q5.** *Five dental technicians have never been requested to use an alternative wire. One technician, who routinely uses 0.030'' SS wire, has been requested to use 0.036'' SS and Wilson 3D preformed lingual arches of 0.028'' diameter.*

**Q6.** *Three technicians routinely use U loops in 6-6 lingual arch space maintainers, two sometimes and one does not use U loops.*

**Q7.** *None of the technicians heat-treats or processes the wire in any other way.*

**Q8.** *All solder the arch to the molar bands. Inserts are used only with Wilson 3D preformed lingual arches.*

**Q9.** *All reported that they were not aware of any difficulties experienced by the clinicians using the lingual arches.*

## 2.2 Materials

Ten mandibular orthodontic study models of patients in the age group of 7-10 years were randomly selected and the lower inter first molar arch (6-6 arch) length and arch width were measured. The arch length was determined by contouring a piece of 0.016'' diameter orthodontic wire to the lingual surfaces of the mandibular teeth starting from the disto-lingual surface of the lower right first molar and continuing around the arcade to the disto-lingual of the lower left first molar. The wire was then straightened to enable measurement. The arch width was calculated measuring the distance between the lingual surfaces of the disto-lingual cusps of the lower first molars. The mean arch length was determined to be about 90 mm and the mean arch width approximately 40 mm. Straight lengths of stainless steel (SS\*) and Co/Cr\* (Elgiloy "blue") round 0.036'' and 0.040'' diameter orthodontic wires and  $\beta$ -Titanium\* (TMA) round 0.036 orthodontic wires were cut into 90 mm lengths. An accuracy of 0.01 mm was achieved by using a precision cutter grinder\*, which cut the ends of the wires

---

\* SS 3M Unitec Corporation, Monrovia, USA.

♣ Co/Cr: Elgiloy 'blue' RMO P.O. Box 17085, Colorado 80217.

♣  $\beta$ -Titanium. ORMCO TMA Archwires, Ormco Corp., 1332 S. Lone Hill Ave., Glendora, CA.

♣ Clarson Tool & Cutter Grinder Mark II, MT 1318, Muneaton, England.

square and flat. This initial preparation of the specimens was completed at the Technical Laboratory of the Department of Physics, University of Witwatersrand, Johannesburg. The entire experiment was performed at the Department of Mechanical Engineering of the University of the Witwatersrand, Johannesburg.

### 2.3 Methodology

Preparation for the experiment involved the bending of a series of lower 6-6 lingual arches of a standard size and contour by using a jig (Fig 2.1). This instrument was an orthodontic wire bending "turret", slightly modified to enable fabrication of wire arches of closely approximate contour. A rigid lever arm was secured to the rotating collar of the turret, placed so that it projected closely above two grooves cut in the cylinder of the turret. The grooves had been milled precisely to accommodate wires of 0.036" and 0.040" diameter. The contour of the turret dictated the contour of the bend of each wire, ensuring that consistency of shape was achieved. A graphic template was used to verify the accuracy of arch form, the arch wire being laid over the scribed arch outline. Final adjustments were made manually.

Five experimental (e) and four control (c) groups were established, depending upon the choice of wire and whether or not the arches had been heat-treated. Each group contained 20 virtually identical lingual arches, bent to the standard contour (Fig 2.2). The specimens were numbered from 1 to 20 in each of the following experimental and control groups.

- Ie and Ic groups- 0.036" SS lingual arch wires
- IIe and IIc groups-0.040" SS lingual arch wires
- IIIe and IIIc groups-0.036" Co/Cr (*Elgiloy* "blue") lingual arch wires
- IVe and IVc groups-0.040" Co/Cr (*Elgiloy* "blue") lingual arch wires
- Ve group- 0.036  $\beta$ -Titanium (TMA) lingual arch wires

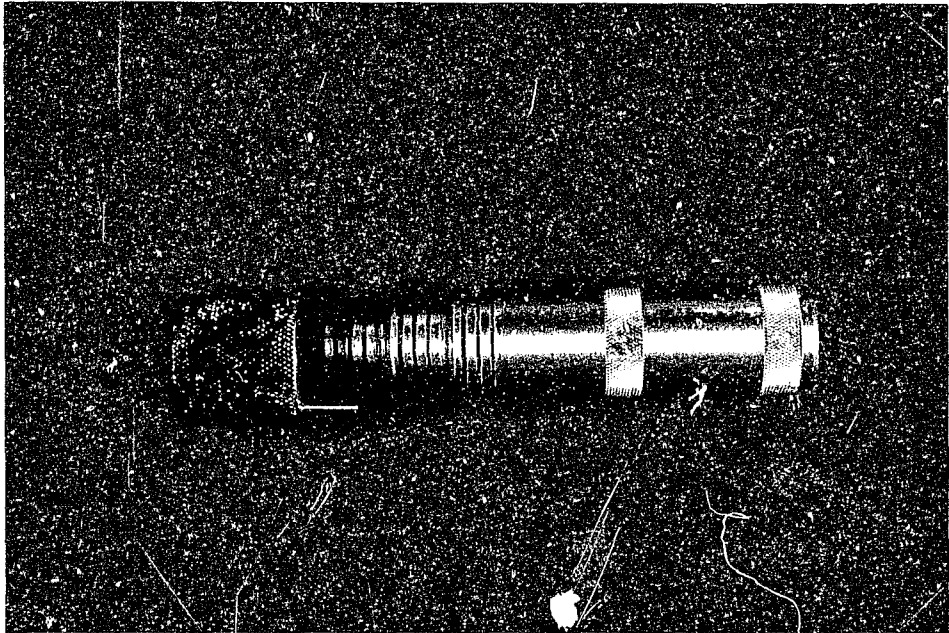

Fig 2.1: Jig for bending of archwires

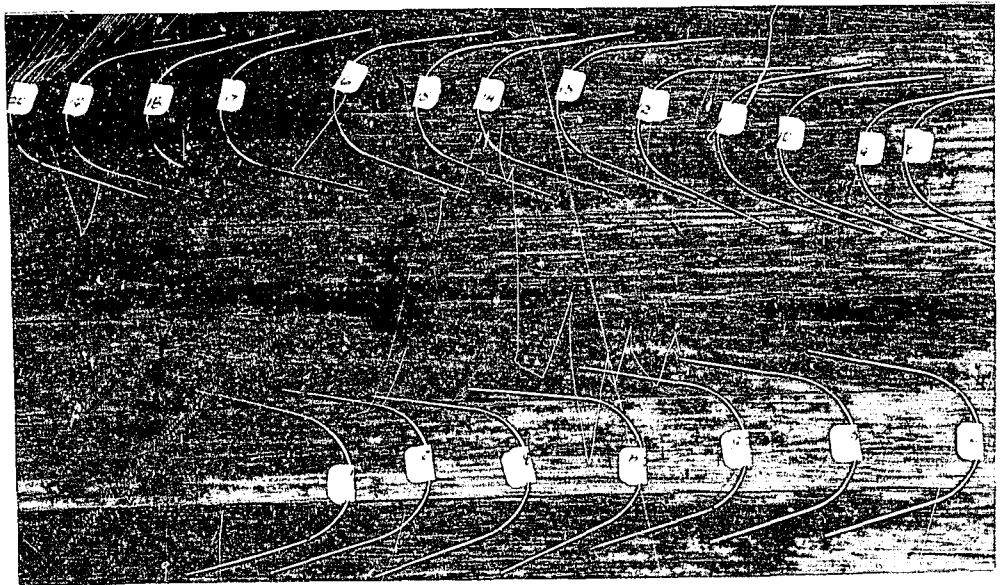

Fig 2.2: A group of 20 samples (archwires)

In every group the interarch width was measured at the ends of the wire immediately after forming of the arches, using the SIP Universal Measuring Machine\* (Fig 2.3).

The SIP Universal Measuring Machine is a precision device capable of recording dimensions to an accuracy of 0.0005 mm. An object on which measurement is to be made is secured onto a cast iron worktable, which can be moved longitudinally and transversely along carriages.

Traverse of the table can be effected in both rapid and fine adjustments. An initial reading is obtained on a longitudinal scale attached below the worktable. A micrometer eyepiece on a reading microscope enables precision measurement to 0.0005 mm. The graduation lines of the standard scale appear magnified 50 times in the field of the eyepiece.

A plastic jig with a groove for placement of the archwire was firmly secured to the worktable. Each arch was placed in this jig ensuring that the projecting ends of the archwire were accurately positioned (Fig 2.4). The precise points for measurement of the interarch width on each arch were determined by the intersection of a laser beam on the cut ends of each sample. All measurements were repeated three times and the mean value was used.

The experimental groups were then heat-treated. The SS arch wires were exposed to 900 degrees F (482° C) for 10 minutes and the Co/Cr to 1200 degrees F (649° C) for 5 minutes in a dental furnace\*.  $\beta$ -Titanium was not heat-treated.

The dimensions of the experimental groups were measured after forming, immediately after heat treatment, four weeks later and finally at eight weeks after bending. The control groups were measured three times: immediately after forming, four and eight weeks later.

---

\* SIP Universal Measuring Machine, Type Mu 214 B, Société D'Instruments, Geneva, Switzerland.

♣ BEGO Eltherm, N161061, V 22, Hz 50, W 3500, Germany.

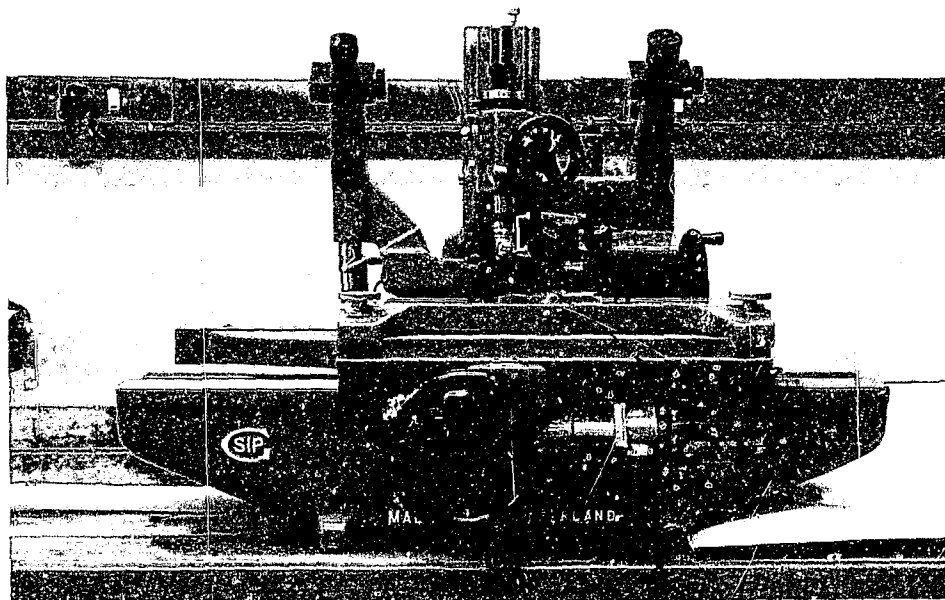

Fig 2.3: SIP Universal Measuring Machine



Fig 2.4: Plastic jig for accurate positioning of the samples in the SIP Universal Measuring Machine

All specimens were kept at mouth temperature (37 degrees C) in an incubator\* for the time periods between the measurements.

The second part of the experiment determined the amount of force required by each non heat-treated arch (control wires and  $\beta$ -Titanium) to compress it back to its original shape. The force was measured using a computer-driven JJ Lloyd\* Tensile Tester (Fig 2.5). The load cell was 100 Newtons (N), the crosshead speed-5mm/min and the accuracy 0.001mm. The force was recorded as an analogue trace on a computer screen connected to the Tensile Tester. The X-axis recorded the distance (in millimetres) travelled by the wire, and the Y-axis recorded the force of compression (in Newtons).

A jig was constructed to secure the archwire into the Tensile Tester with the arch on its side, the two ends being in the same vertical plane. The jig consisted of two main components. The first component (Fig 2.6) was designed so that it could be firmly fixed into the lower member of the JJ Lloyd Tensile Tester while at the same time it could secure the upper end of the arch wire in the desired position. A small plate with a central V shaped groove (2 mm x 4 mm x 2 mm) was attached to the main body via two screws. The archwire was secured by a modified clamp, which enabled proper positioning of the upper end of the archwire into the jig and at the same time eliminated any rotational movement of the test wire.

The second component of the jig was attached to the upper (movable) member of the machine and to the bottom end of the arch. It consisted of a wire (0.018") soldered to a hook (0.050" orthodontic wire) on the one end and a tube (0.040") on the other (Fig 2.7). The hook and the small cylinder secured the wire into the Tensile Tester. The tube was used to engage the lower end of the archwire (Fig 2.8).

The upper end of the lingual arch was firmly fixed into the Tensile Tester while the lower end was pulled upward a distance equal to the overall expansion after a period of eight weeks (Fig 2.9). This movement effectively returned the specimen to its original dimension.

---

\* Incubator Labotec Model 319, Labotec Laboratory Equipment, Johannesburg.

♣ Tensile Tester JJ Lloyd, Instruments, Warsash, Southampton, UK.

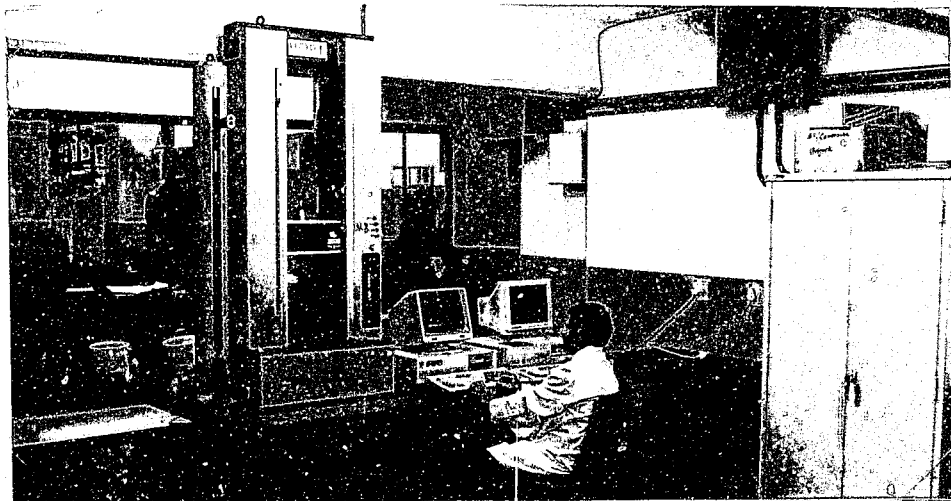

Fig 2.5: JJ Lloyd Tensile Tester

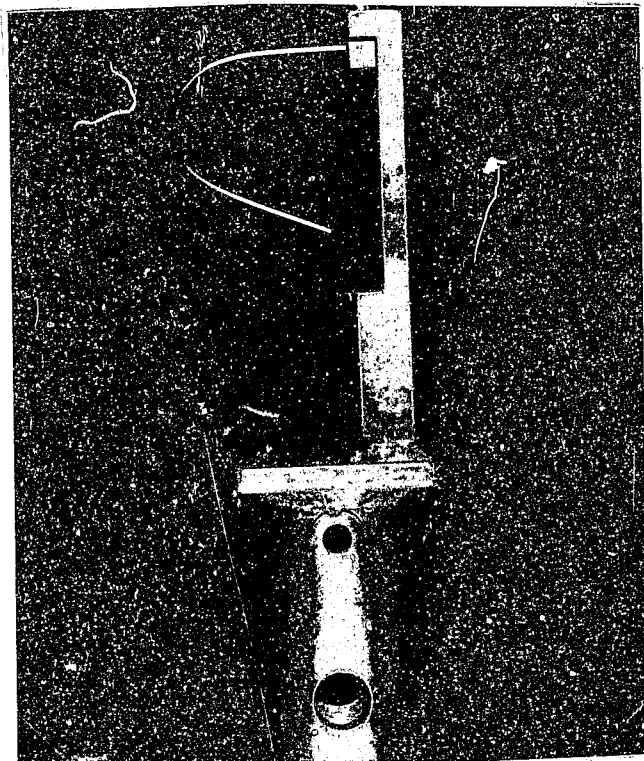

Fig 2.6: Jig for securing the archwire into the Tensile Tester- *first component*

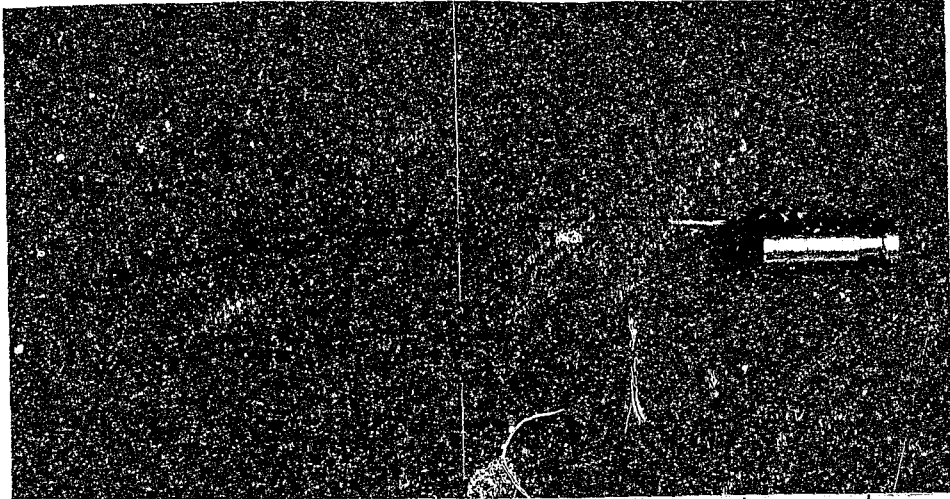

Fig 2.7: Jig for securing the archwire into the Tensile Tester- *second component*

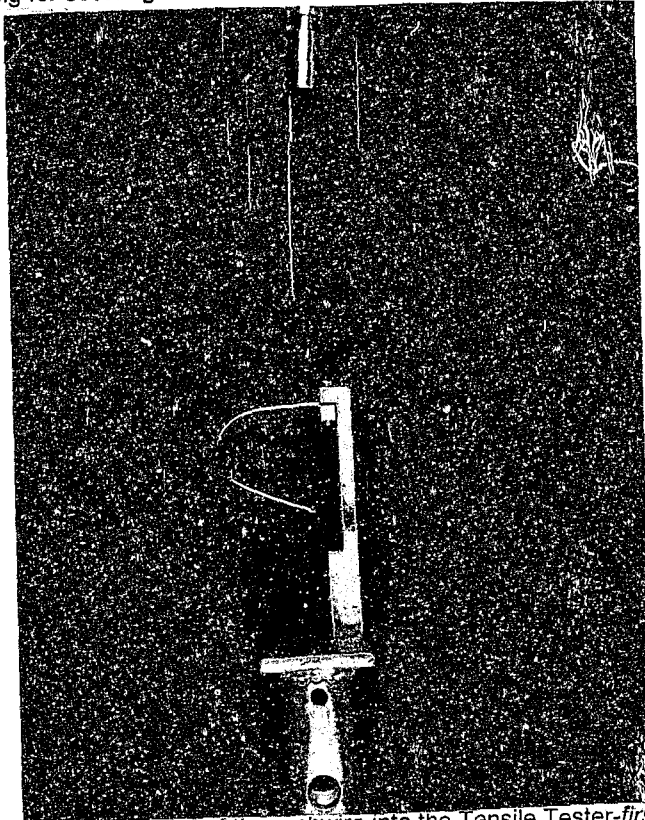

Fig 2.8: Jig for positioning of the archwire into the Tensile Tester-*first and second components*

The computer-generated graphs illustrated the compression force (load) as a linear progression of the distance. The slope was determined from the graph and in this way it was possible to calculate the force as a function of the distance (Fig 2.10).

#### 2.4 Statistical Analysis

The statistical analysis was carried out in consultation with the Department of Statistics, the South African Medical Research Institute.

The interarch distance of each arch was computed by subtracting measurements of the position of the left endpoints from measurements of the position of the right end points. Each measurement was repeated three times and the mean value was determined. In each group, these data were pooled, and the average width was calculated, together with standard deviation and the range. These measurements provided the baseline descriptive analysis.

In a comparative analysis an Analysis of Variance (Anova) model was implemented using the average width as a dependent variable and wire group (SS, Co/Cr {*Elgiloy*} "blue", and  $\beta$ -Titanium {TMA}), and group type (heat and non-heat treated) as factors.

For the second part of the experiment an Anova test was used to determine the significance of the amount of force generated as a result of dimensional changes of the control archwires.

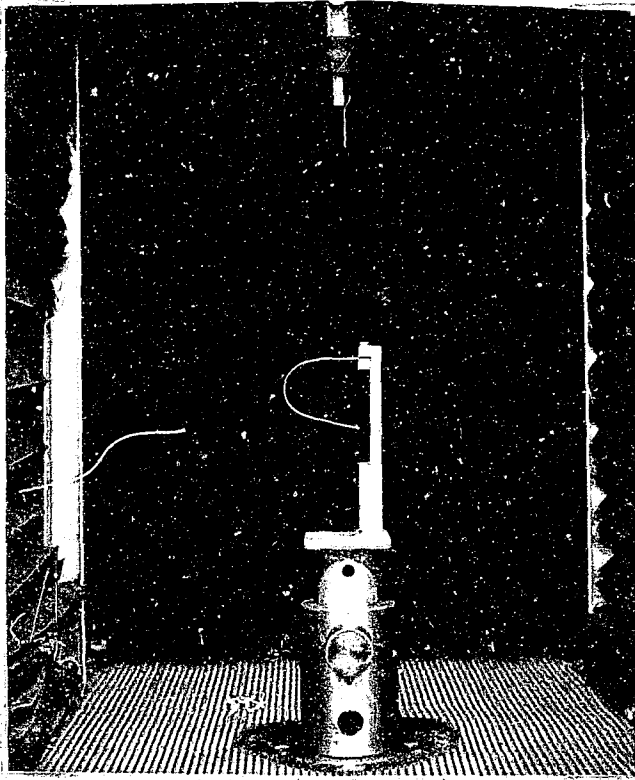

Fig 2.9: Position of the archwire during compression  
Lloyd Instruments Data Analysis

Tensile Testing

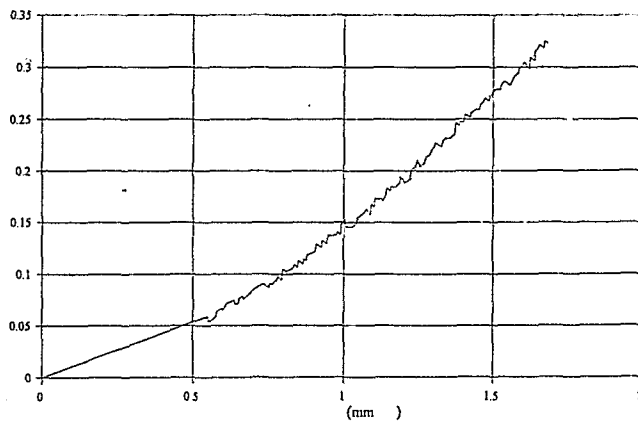

Fig 2.10: Computer generated graph illustrating the compression force

## CHAPTER 3

### 3.0 RESULTS

The data gathered reflected both the changes in arch widths which may have occurred, and also the force levels, which may have been generated by any expansion of the lingual arches. The data were analysed group by group to produce descriptive statistics and then comparative analyses were completed to enable the identification of any statistically significant differences between the mean data. The results confirmed a variety of responses, not only between groups but also within groups, and identified some performance levels, which could be of clinical import.

#### **3.1 Error of the Method**

Five repeated readings in mm were taken on the SIP Universal Measuring Machine for each of ten randomly selected samples (archwires). The standard deviations of the five readings for every sample as well as the standard errors were calculated. The mean standard error (Std. Error) was 0.012969 with a maximum value of 0.053436 and minimum of 0.0. The  $t$  test  $\{t(df) = 0.57559$  at  $p\text{-value} < 0.05$  ( $t_{0,05}=2,23$ );  $\mu = 0.01$  } showed that the Std. error was not significant. These results indicated that the operator was capable of using the instrument precisely and that three repeated readings were sufficient.

All procedures had been standardised and the protocol was adhered to for all experimental procedures. Each measurement on the SIP Universal Measuring Machine during the experiment was repeated three times and the mean value was calculated.

Every group demonstrated a mean expansion at every stage at which measurements were taken. Considerable variation in the responses was characteristic.

## DESCRIPTIVE STATISTICS

### 3.2 Expansion due to Heat Treatment

The data confirm that heat treating wires results in an immediate and quite noticeable expansion across the arch form. Table 3.1 records the expansion effects recorded by the experimental group wires when the measurements were taken just after completion of the heat treating process.

Expansion was much greater in the SS wires, both 0.036'' and 0.040''. The mean increase in arch width for the SS 0.036'' wires was 4.91 mm, whilst the SS 0.040'' group expanded a mean of 4.19 mm. *Elgiloy* samples however showed a lower mean expansion after heat treatment of 1.25 mm for the 0.036'' wires and only 0.51 mm for the 0.040'' group (Table 3.1 & Fig 3.1; 3.2; 3.3; 3.4; 3.5).

Not only were the changes noted in the *Elgiloy* groups small, but also two wires in these samples actually recorded a contraction after the heat treatments. Despite that apparent anomaly, the *Elgiloy* groups displayed smaller variations with standard deviations of 0.3975 for *Elgiloy* 0.040'' and 0.6648 for *Elgiloy* 0.036''. The SS groups had standard deviations of 0.7829 and 1.8073 for SS 0.040'' and SS 0.036'' respectively.

### 3.3 Expansion of Control (Non-heat-treated) Archwires

*Measurements made at four-week interval (stage), recording changes from initial bending to four weeks later*

All control (non-heat-treated) wires changed in dimension during the first four weeks. The greatest mean expansion was recorded for *Elgiloy* 0.036'' at 0.831 mm, followed by SS 0.040'' at 0.580 mm, with  $\beta$ -Titanium 0.036'' (0.550 mm) and SS 0.036'' (0.435 mm)

showing lesser expansion Table 3.2). The 0.040'' *Elgiloy* demonstrated appreciable stability, for expansion over the first four weeks was only 0.005 mm. The standard deviations were also of a relatively low level.

*Measurements made at the eight-week interval, recording changes from the four-week to the eight-week stage*

There was little expansion during this period from any of the sample wires. *Elgiloy* 0.040'' expanded on average 0.148 mm, the highest amount, whilst the  $\beta$ -Titanium 0.036'' wire expanded the least for this period, a barely noticeable 0.014 mm (Table 3.3).

Total expansion from initial bending to the eight-week stage for this control, non-heat-treated sample, was of a relatively low level. (Table 3.4 and Fig 3.6).

Indubitably it was the *Elgiloy* 0.036'' wires, which demonstrated the greatest change, but even that mean expansion was no more than 0.853 mm. The single wire showing the greatest expansion was an *Elgiloy* of 0.036'' diameter, which expanded 2.833 mm over the eight-week period. It was an *Elgiloy* 0.040'' archwire which was the most stable, recording a change of only 0.03 mm. One archwire in *Elgiloy* 0.040'' control group and five archwires in  $\beta$ -Titanium control group experienced an overall constriction in the interarch distance.

### **3.4 Expansion of Experimental (Heat-treated) Archwires**

There was little further expansion in the experimental group after the rather marked immediate response to the heat-treatment process itself. Measurements made at the four and eight-week stages were cast against the baseline record of the arch dimensions after heat-treatment. The *Elgiloy* heat-treated samples recorded the greatest stability.

*Measurements at the four-week stage.*

All groups recorded mean changes of less than 0.076 mm (SS 0.036"). Indeed, the 0.036 *Elgiloy* was almost unchanged at a mean of 0.005 mm expansion (Table 3.2).

*Measurements from the four-week to the eight-week stage.*

Between the four and eight week levels this stability was observed to continue although one set of wires did record a mean expansion approaching one quarter of a millimetre (the 0.036" SS at 0.205 mm) (Table 3.3).

*Total expansion during the eight-week period after heat-treatment.*

All sample wires demonstrated stable dimensions through the period of the experiment. Only the thinner SS wire (0.036") recorded a mean value close to a third of a millimetre (0.212 mm) (Table 3.4 & Fig 3.7). Overall, the standard deviations confirm the relative lack of change with values of 0.22363 for *Elgiloy* 0.040", 0.33827 for *Elgiloy* 0.036", 0.59252 for SS 0.040", and 0.15862 for SS 0.036".

Three archwires SS 0.036" diameter, four archwires *Elgiloy* 0.040" and six-*Elgiloy* 0.036" experienced an overall contraction.

## COMPARATIVE ANALYSES (ANALYSIS OF VARIANCE)

### 3.5 Comparison of Heat-treated and Non-heat-treated Wires of the same Material and Size

#### *Measurements at the four-week stage*

For SS 0.036'' and SS 0.040'' as well as for *Elgiloy* 0.036'' wires there was a statistically significant lower mean expansion recorded for the heat-treated when compared with the non-heat-treated arches. Although the mean expansion recorded by the non-heat-treated *Elgiloy* 0.040'' was lower than the one for the heat-treated matched sample the difference between the means was of no statistical significance.

#### *Measurements at the eight-week stage*

Significantly greater was the mean across-arch dimensional change of the SS 0.036'' and SS 0.040'' non-heat-treated wires when compared with the heat-treated SS 0.036'' and SS 0.040'' wires (0.481 mm vs 0.212 mm and 0.639 mm vs 0.130 mm). *Elgiloy* 0.040'' non-heat-treated samples showed also greater expansion than did the matched heat-treated group. All these results were without any statistical significance. However, the increased mean dimensional change of the *Elgiloy* 0.036'' non-heat-treated wires (0.853 mm) when compared with *Elgiloy* heat-treated arches (0.086 mm) did record a statistically significant difference.

### 3.6 Comparison of Wires of Differing Materials and Sizes

#### 3.6.1 Heat-treated Wires

##### *Measurements at the four-week stage*

When the response of the heat-treated wires of different sizes were compared there was a greater mean expansion for SS 0.036" wires (0.076 mm) than for SS 0.040" (0.028 mm) and for *Elgiloy* 0.036" (0.005 mm) compared with *Elgiloy* 0.040" (0.052 mm) (Table 3.2). Although the *Elgiloy* 0.036" showed the lowest mean expansion the difference between the means was of no statistical significance.

##### *Measurements at the eight-week stage*

Although SS 0.036" heat-treated arch wires showed a greater mean expansion at the eight-week stage than the rest of the experimental wires, this difference was not statistically significant (Table 3.4).

#### 3.6.2 Non-heat-treated Wires

Comparisons of the control wires did reveal some relevant differences in response.

##### *Measurements at the four-week stage*

There was a statistically significant dimensional change for SS 0.036" and SS 0.040" when the means were compared with those for *Elgiloy* 0.036" and *Elgiloy* 0.040". The expansion of the 0.036" *Elgiloy* arches (0.831mm) was significantly greater than that of the 0.040"

(0.005 mm). The expansion of SS 0.040'' was more than the mean recorded for SS 0.036'' wires (0.580 mm and 0.435 mm respectively) but the difference between the means was not statistically significant.  $\beta$ -Titanium archwires showed statistically significant greater mean change in the inter-arch width than did *Elgiloy* 0.040'' at the four week stage (0.550 mm vs 0.005 mm) (Table 3.2).

#### *Measurements at eight-week stage*

The mean total expansion of the non-heat-treated samples after the full eight-week experimental period demonstrated maximum stability for *Elgiloy* 0.040'' (only 0.153 mm) (Table 3.4). This was statistically significant when compared with the mean total expansions for SS 0.040'', *Elgiloy* 0.036'' and  $\beta$ -Titanium 0.036''. The difference in the mean expansion between SS 0.036'' and SS 0.040'' was not statistically significant as was also the comparison between the means for the SS and  $\beta$ -Titanium wires.

#### *Measurements from the four-week to the eight-week stage*

The expansion, which had occurred between the fourth and the eighth weeks for all archwires, was of small dimensional change and none of the data revealed any statistically significant differences.

While all the control (non-heat-treated) archwires had shown greater dimensional change during the first four weeks (except *Elgiloy* 0.040'') the experimental wires demonstrated greater expansion during the second four weeks (except *Elgiloy* 0.040'') (Table 3.3).

Statistical analysis (Anova test at a probability level of 0.0001) showed there was evidence of difference in arch width between the groups, which is an indicator of the effect of the material and size of the archwires on their final expansion.

Heat treatment is statistically significant for the arch width change experienced by *Elgiloy* and SS wires. The main effect appears to be in the reduction of expansion during the first four weeks of the observations. Between the fourth and the eighth weeks the heat-treated groups actually expanded more than did the non-heat-treated samples (except *Elgiloy* 0.040'') (Table 3.3).

### 3.7 Force generated as a Result of the Expansion of the Non-heat-treated Wires

A strong linear relationship existed between the overall amount of expansion of the control wires and the forces which would have been generated by the expansion. The 0.036'' *Elgiloy* offered the greatest mean force of 14.0102 gms. The remaining arches recorded force levels ranging from 3.0612 gms to 11.0918 gms (Table 3.5 & Fig 3.8).

The statistical analysis of ANOVA indicated that SS 0.040'' and *Elgiloy* 0.036'' had mean force values not statistically significantly different, and the same finding applied to the comparison of the data for *Elgiloy* 0.040'' and  $\beta$ -Titanium 0.036''. A significant difference existed between SS 0.040'' and *Elgiloy* 0.036'' when compared with *Elgiloy* 0.040'' and  $\beta$ -Titanium 0.036'' (Table 3.5).

The maximum force value of 0.1882 N (19.2040 gms) was recorded for an SS 0.040'' archwire, while the minimum force value of 0.0067 N (0.6840 gms) was offered by an SS 0.036'' archwire. The  $\beta$ -Titanium experimental group had the highest standard deviation of 0.095058. The SS groups displayed the smallest variations with standard deviations of 0.037381 for SS 0.040'' and 0.033418 for SS 0.036'' archwires (Table 3.5).

Table 3.1: Expansion of experimental archwires in mm immediately after heat treatment

sample	SS		Elgiloy	
	0.036"	0.040"	0.040"	0.036"
1	4.84	3.81	-0.53	1.06
2	4.95	4.68	0.39	1.14
3	4.77	3.20	0.36	0.69
4	4.22	3.45	0.56	1.85
5	4.13	5.04	0.69	1.47
6	4.74	3.89	0.17	1.92
7	5.68	5.05	0.58	0.81
8	2.39	4.58	0.54	1.29
9	6.36	4.57	0.06	1.44
10	2.87	5.19	0.89	2.65
11	2.91	4.78	0.54	1.18
12	4.37	3.08	0.88	0.83
13	5.30	4.66	0.30	1.17
14	4.75	5.18	0.09	1.36
15	4.68	3.42	0.29	1.01
16	5.23	3.47	1.53	-0.54
17	1.44	4.64	0.50	1.96
18	5.41	2.57	0.40	0.72
19	4.64	3.95	0.81	2.04
20	4.56	4.52	0.67	0.91
<b>mean</b>	<b>4.91</b>	<b>4.19</b>	<b>0.51</b>	<b>1.25</b>
Std. Dev.	1.8073	0.7829	0.3975	0.6648

Table 3.2: Mean expansion in mm of archwires at the 4th week and results of Anova test

material & size	heat treated		non-heat treated		<u>Levels</u>	<u>of stat</u> <u>signif</u>
	expan	Std.Dev.	expan	Std.Dev.		
SS 0.036''	0.076	0.31180	0.435	0.15279	Prob >F	0.0001
SS 0.040''	0.028	0.26509	0.580	0.22319	s.e. (diff)	0.1646
Elgiloy 0.036''	0.005	0.25059	0.831	0.50957	sig diff>	0.33 mm
Elgiloy 0.040''	0.052	0.76388	0.005	0.45074		
$\beta$ -Ti 0.036''			0.550	0.76389		

Table 3.3: Mean expansion in mm of archwires between 4th and 8th week and results of Anova test

material & size	heat treated		non-heat treated		<u>Levels</u>	<u>of stat</u> <u>signif</u>
	expan	Std.Dev.	expan	Std.Dev.		
SS 0.036''	0.205	0.23406	0.045	0.12684	Prob >F	0.0002
SS 0.040''	0.103	0.53493	0.056	0.09964	s.e.(diff)	0.192
Elgiloy 0.036''	0.091	0.22286	0.022	0.13788	sig diff>	0.384 mm
Elgiloy 0.040''	0.045	0.07139	0.148	0.39890		
$\beta$ -Ti 0.036''			0.014	0.55551		

Table 3.4: Mean expansion in mm of the archwires at the 8th week and results of Anova test

material & size	heat treated		non-heat treated		<u>Levels:</u>	<u>of stat</u> <u>signif</u>
	expan.	Std.Dev.	expan	Std.Dev.		
SS 0.036"	0.212	0.15862	0.481	0.16054	Prob > F	0.9996
SS 0.040"	0.130	0.59252	0.639	0.23204	s.e.(diff)	0.2
Elgiloy 0.036"	0.086	0.33827	0.853	0.49767	sig diff>	0.4mm
Elgiloy 0.040"	0.097	0.22363	0.153	0.29580		
$\beta$ -Ti 0.036"			0.565	0.93365		

Table 3.5: Force in N required to compress the archwires back to the original shape and the results of the comparative analysis (Anova test)

sample	Force/ SS 0.036``	Force/ SS 0.040``	Force/ Elgiloy 0.036``	Force/ Elgiloy 0.040``	Force/ $\beta$ -Ti 0.036``	
1	0.0498	0.1372	0.1472	0.0235	0.0207	
2	0.1349	0.1371	0.0581	0.0332	0.0978	
3	0.0894	0.1882	0.1112	0.0371	-----	
4	0.0648	0.1005	0.1123	0.0075	0.0897	
5	0.0709	0.0996	0.1165	0.0578	0.0247	
6	0.0872	0.1676	0.0765	0.0503	0.0476	
7	0.0696	0.1025	0.1074	0.0243	0.0395	
8	0.0851	0.0821	0.2005	0.0935	0.0342	
9	0.0343	0.0755	0.4110	0.0138	0.0171	
10	0.0660	0.0861	0.1078	0.0436	0.1198	
11	0.0785	0.1280	-----	0.1651	0.0462	
12	0.0533	0.0387	-----	0.0873	0.0293	
13	0.0720	0.0363	0.1148	0.0067	-0.312	
14	0.0653	0.1097	0.1500	-0.1530	0.0266	
15	0.1465	0.1073	-----	0.0244	-0.0289	
16	0.0843	0.0857	0.1389	0.0142	0.0373	
17	0.0067	0.1225	0.0952	0.0154	0.0373	
18	0.0589	0.1011	0.1533	0.0112	0.0497	<b>Levels of stat</b>
19	0.0130	0.1320	0.1197	0.0203	0.1775	<b>significance</b>
20	0.0456	0.1369	0.1134	0.0250	0.0100	Prob > F 0.0001
mean F in N	<b>0.0688</b>	<b>0.1087</b>	<b>0.1372</b>	<b>0.0300</b>	<b>0.0275</b>	s.e. (diff) 0.021
Std. Dev.	0.033418	0.037381	0.077482	0.057560	0.095058	sig diff >0.042 N
mean F in grams	<b>7.0204</b>	<b>11.0918</b>	<b>14.0102</b>	<b>3.0612</b>	<b>2.8061</b>	

----- absent  
measurement

gram=  
Newton x1000  
9.8

Fig 3.1: Mean expansion immediately after heat treatment

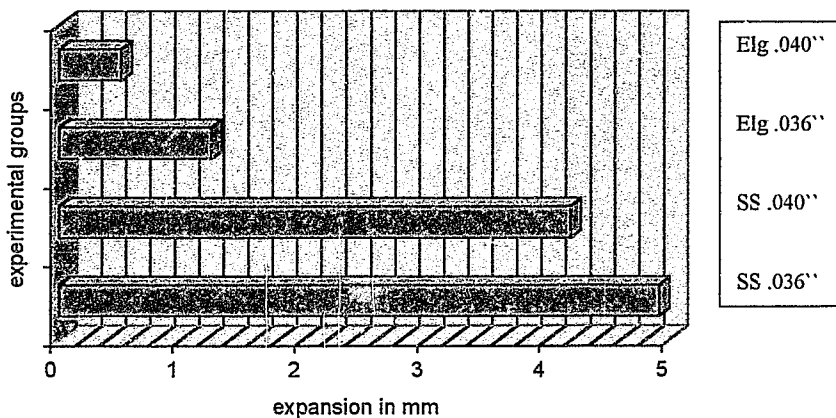

Fig 3.2: Expansion of SS 0.036" archwires immediately after heat treatment

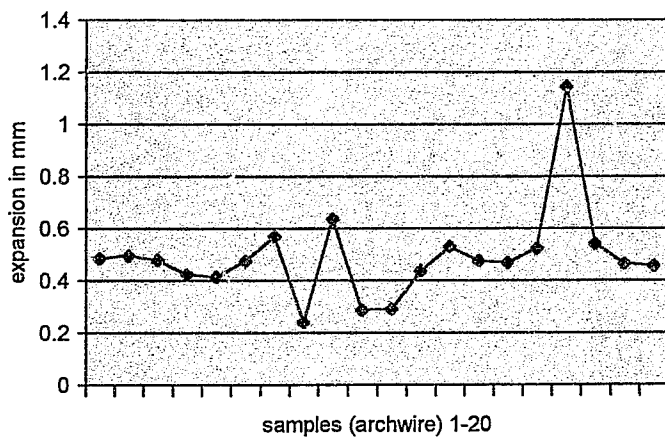

Fig 3.3: Expansion SS 0.040" archwires immediately after heat treatment

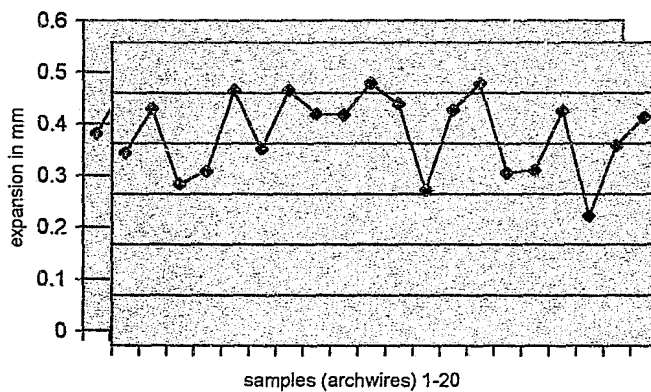

Fig 3.4: Expansion of 0.040" Elgiloy archwires immediately after heat treatment

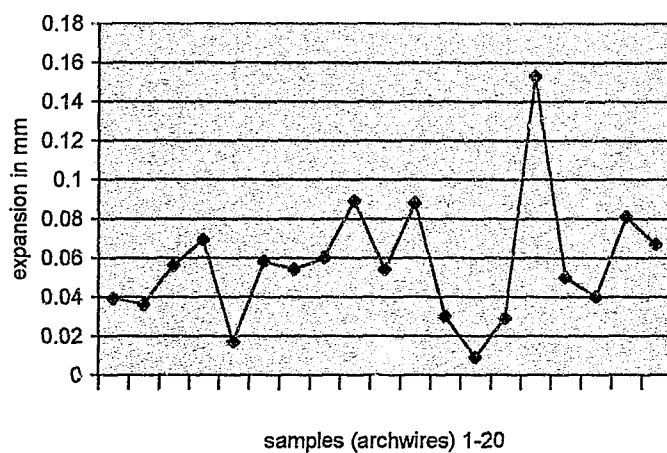

Fig 3.5: Expansion of Elgiloy 0.036" archwires immediately after heat treatment

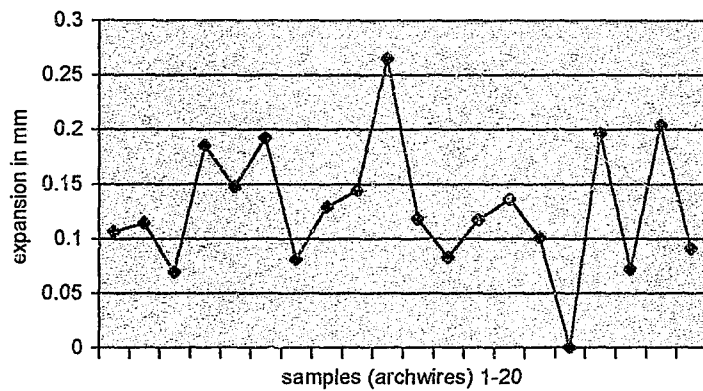

Fig 3.6: Mean expansion of the non-heat-treated archwires at the 8th week

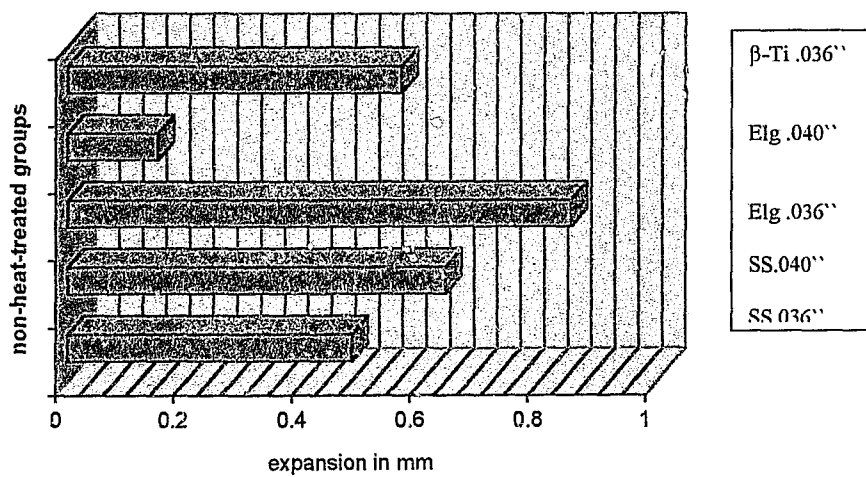

Fig 3.7: Mean expansion of the heat-treated archwires at the 8th week

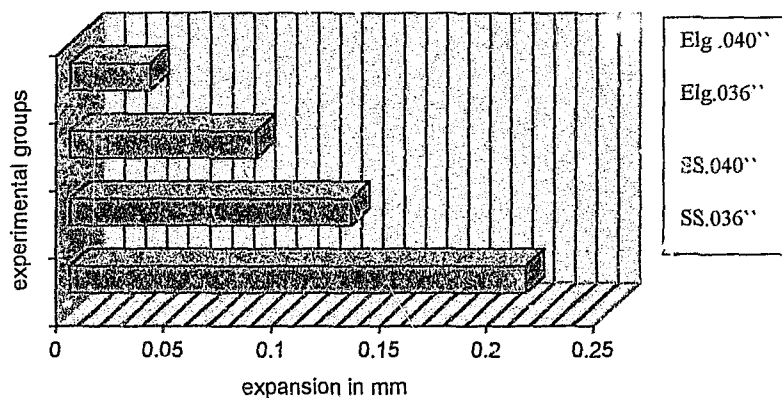
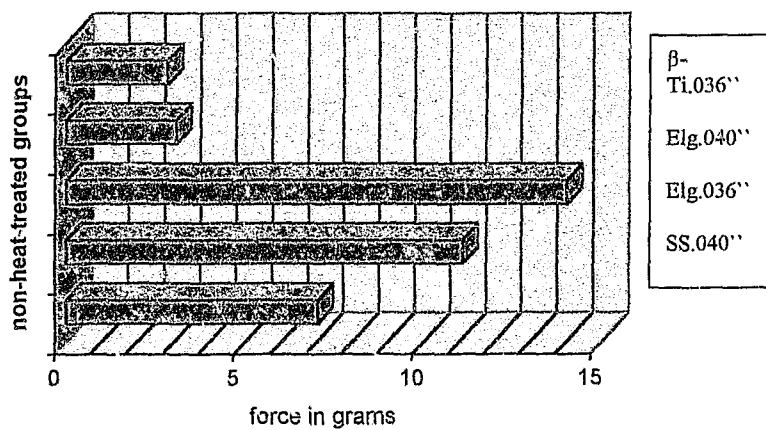

Fig 3.8: Mean force in grams required to compress the non-heat-treated archwires back to the original shape



## CHAPTER 4

### 4.0 DISCUSSION

Space maintenance is integral to the concept of preventive dentistry. Properly placed space maintaining appliances prevent tooth migration, arch space reduction and reduce the occurrence of malocclusion in the permanent dentition following the premature loss of primary teeth. However their use is not without the potential of associated difficulties. In the dental literature there are many case reports of problems related to the use of space maintainers, including soft tissue impingement, tissue erosion, pain, unwanted tooth movement, plaque accumulation and broken appliances (Hill, Sorenson & Mink, 37; Baroni, Franchini & Rimondini, 38).

Most of these clinical complications could be avoided if the appliances were constructed from materials and according to procedures validated by scientific trials.

When a lingual arch space maintainer is used to maintain the lower arch perimeter it is axiomatic that this appliance remains passive for the period of treatment. From a clinical point of view the term passive means that the orthodontic wire used for construction of the maintainer does not exert forces which can cause movement of the teeth. Technicians and clinicians are fortunate in having a choice of wires not only of varying size but also of different metallurgical structure and characteristics. Factors influencing their choice may include expense, ease of manipulation, joinability and behaviour of the wire after it has been placed in the mouth. Of all these factors, the last is probably the most important.

The use of a wire of appropriate size and metallurgy suitably manipulated and, possibly adequately heat-treated (Thurow, 20), may be essential to achieve the desired stability of arch form.

The preliminary survey of local dental technicians had revealed an illuminating fact, namely that none heat treated the lingual arches they manufactured. Furthermore a considerable variety of wires had been chosen by the technicians.

Heat treatment has been strongly recommended by several authors to ensure stability of the SS and *Elgiloy* orthodontic wires (Thurrow, 20; Kapila & Sachdeva, 17). For  $\beta$ -Titanium orthodontic wires, however, the originators, Burstone and Goldberg (13) had not recommended heat treatment.

The stress-relief (heat treatment) of orthodontic wires can be performed using different methods. The work of Durr *et al.* (24) indicates that the method of heat-treatment can influence the final dimensional change of the arch wires.

In this study the use of a dental furnace was preferred as this ensures favourable uniform heating (Thurrow, 20).

There is a paucity of evidence on the behaviour of wires used for lingual arches and lack of sufficient information about the clinical necessity for heat treatment, which prompted this investigation. It is important to know whether the different wire materials and sizes demonstrate differing stability and whether this stability improves after heat treatment.

The experiment was performed *in vitro* and did not follow precisely the *in vivo* situation. Procedures like soldering, polishing and refitting in the laboratory as well as trial fitting and cementation in the mouth were not replicated when the behaviour of the wire was tested in the laboratory. Furthermore after the initial heat treatment the archwires were not reshaped back to their original dimension which may be required in a clinical situation. The stage of readjustment of the archwires after heat treatment was also not considered in the investigation of Nagatani *et al.* (33).

The laboratory test procedures were carried out in a standard format, using techniques proven to be accurate and reproducible.

#### 4.1. Could the performance of the wire be improved by heat treatment?

##### Would different wire materials and sizes react in similar fashion after being heat-treated?

The experiment confirmed previous reports (Nagatani *et al.*, 33; Durr *et al.*, 24) which had shown that heat treating arches resulted in immediate noticeable expansion across the distal end of the arch. The amount of expansion varied for the different materials and sizes of orthodontic wires. The greatest expansion was recorded for the SS 0.036" in diameter and the least for *Elgiloy* 0.040".

However, expansion did not then cease, but continued over the eight-week trial period. Combined, these dimensional changes could be quite large. As an example for SS 0.036" diameter orthodontic wire, this overall expansion would be  $4.912 \text{ mm} + 0.223 \text{ mm} = 5.135 \text{ mm}$ . Therefore if an appliance constructed from SS is heat-treated, it would be prudent to ensure that it is checked and readjusted on the working cast before cementation. For *Elgiloy* 0.040" diameter arch wires the overall expansion, however, was equal to only 0.61 mm making such readjustment much less critical.

After the initial marked expansion the change in the dimension of the experimental heat-treated archwires was generally significantly less than that of the control groups for all wire types. These results concurred with those of Durr *et al.* (24), who tested 0.036" diameter Co/Cr orthodontic wires.

The study of Nagatani *et al.* (33) also showed greater expansion of the non heat-treated SS 0.036" orthodontic archwires when compared with the heat-treated samples after initial expansion, which is in broad agreement with the results of this study. Differences in the results from those obtained by Nagatani *et al.* (33) may be related to different methods of heat-treatment as well as the use of different lengths of the specimens. While Nagatani *et al.* (33) heat-treated the archwires in 20 mm segments with an orthodontic spot welder the stress relief of the orthodontic wires in the current study was performed in a dental furnace, which

according to Thurow (20) is the most reliable procedure. Only a dental furnace can provide a relatively uniform temperature during the time of the heat-treatment procedure.

Metallurgically speaking this is desirable.

The expansion of the control groups continued over the experimental period of eight weeks, demonstrating greater dimensional change in the first four weeks. The change in dimension for the non-heat-treated samples after the fourth week was minimal and was strongly dependent on the material and size of the wires.

The heat-treated SS arches demonstrated little expansion after the initial response. Here, too, the expansion was greater in the first four-week period (SS 0.036''-0.435 mm; SS 0.040''-0.028 mm) than in the second (SS 0.036''-0.061 mm; SS 0.040''-0.0103 mm).

Maximum stability was achieved with Co/Cr (*Elgiloy* "blue") 0.040'' archwire. The 0.040'' diameter stainless steel non-heat-treated arches expanded more than did the 0.036'' but just the opposite was recorded for the *Elgiloy*, where 0.040'' non-heat treated arches had a smaller change in dimension than the 0.036''.

*Elgiloy* heat-treated archwires exhibited greater stability than the SS archwires but the mean difference in the dimensional change was statistically not significant.

The greater material stiffness of the *Elgiloy* when compared with SS (1.2:1; Kapila & Sachdeva, 17) may explain the greater stability of the *Elgiloy* heat-treated archwires.

These results suggest some correlation between the wire material and the stability of the arch forms. It would appear that 0.040'' diameter *Elgiloy* archwire might be the optimum choice, and that heat treatment may indeed enhance stability.

According to the Larson-Miller equation  $\{ T(\log t+20)(10^{-3}) \}$  the relief of residual stresses in this study for SS archwires equals 9.243  $\{ 482(\log 0.15+20)(10^{-3})=9.243 \}$ , while for *Elgiloy* archwires is 12.279  $\{ 649(\log 0.08+20)(10^{-3})=12.279 \}$ .

*Performance of wire is improved by heat treatment. Different wires and sizes react differently.*

#### **4.2 Could orthodontic wires confidently be used for fabrication of space maintainers without heat treatment?**

This study showed that orthodontic archwires of proper sizes and metallurgies might be used for construction of lower lingual arch space maintainers without heat-treatment. The expansion of the non-heat-treated (control) groups of archwires was minimal and insufficient to be of any clinical danger. Furthermore heat-treatment *per se* may lead to metal ion release, having deleterious effects on the behaviour and appearance of the archwires (Gjerdet, 27).

#### **4.3 Would the dimensional change of a non-heat-treated wire be such that actual tooth movement could occur?**

Is there a threshold of force which may be regarded as the minimum that may produce tooth movement?

When considering the possible clinical effects of a given force, the important factor is not the absolute magnitude of the force, but the pressure (the force per unit area) generated in the periodontal ligament. The surface area of the root is therefore an important factor determining the effect of the applied force. A given force might be sufficient to initiate the cellular reactions leading to movement in a tooth with a smaller root area, but is insufficient for movement of a tooth with a large root area (Williams, Cook, Isaacson *et al.*, 39).

A further factor that will influence the tooth movement as a result of force application is the time frame.

Ackerman, Cohen & Cohen (40), using platinum-cobalt magnets placed on either side of the sternum keel of a pigeon, found that forces ranging from as little as 33 up to nearly 548 grams per square centimetre were all capable of initiating bone resorption.

Weinstein (41) pointed out that muscle forces of values as low as 1.68 grams above the resting force, if acting over a sufficient time, are capable of moving teeth.

In general, most individual teeth will respond favourably to an orthodontic force in the 25- to 100-gram range, where the lower range is adequate for the smaller teeth. Molar teeth require more force because of the larger area of periodontal attachment (Thurow, 20), and the greater surface of bone which must be resorbed. In the clinical application it will be necessary to take into consideration the root morphology and the duration of the force application.

In the present experiment the non-heat-treated arches were compressed back to their original dimension. The required compression force was interpreted as an indication of the forces that would have been delivered by the expansion of the arch wires. Clinically this is the level of the force which the expanding lingual arch would deliver to the first permanent molars, at least until other teeth were contacted.

The evaluation of the results of this study showed that the forces which would be generated as a result of the compression of the wires, were of rather small levels.

According to Proffit (14) the force that is required for tipping of the molar teeth is 75 grams. Even the greatest force (14.0102 grams) recorded in this study for non-heat-treated *Elgiloy* 0.036" diameter after allowing a period of eight weeks for expansion will probably be far too small to induce bone resorption around the root surfaces of the lower first molar teeth. Therefore the amount of the associated force does not appear sufficient to cause tooth movement and is unlikely to constitute a clinical danger.

It is not possible to compare the results directly with those of Nagatani *et al.* (33). The fact that their experimental design was different could explain their reported forces of 35 grams for 0.66 mm expansion of 0.036" stainless steel arch wires. Nagatani *et al.* (33) used wire specimens of a smaller length (shorter and therefore a stiffer lever arm during compression).

#### **4.4 Would the wire material and size determine the stability of the archwire and if so would this be clinically significant?**

The aim of the orthodontist in using a lower fixed space maintainer is to maintain the lingual arch perimeter unchanged in a certain time frame, without causing any deleterious effects to the stomatognathic system.

This experiment indicated that stainless steel, *Elgiloy* and  $\beta$ -Titanium were all wires with good properties that could be utilised for fabrication of lower lingual arch space maintainers. It is noteworthy that although *Elgiloy* demonstrated the best stability from all heat treated as well as non-heat treated wires the differences in the interarch expansion were so little that they would be of no clinical significance.  $\beta$ -Titanium archwires demonstrated some overall expansion at the 8<sup>th</sup> week but the mean force required to bring these arches back to the original shape was very little.  $\beta$ -Titanium could therefore be a more desirable wire for fabrication of lower lingual arch space maintainers

*Heat-treatment of lingual arches used for space maintainers seems to be of little clinical significance. If the technician or the clinician exercising his own discretion decides on heat-treatment the readjustment of the archwire on the working model before cementation is required.*

## CHAPTER 5

### 5.0 CONCLUSIONS

1. The varying behaviour of wires of different metallurgies and configuration emphasise the need for appropriate selection criteria in the choice of wires for specific purpose in orthodontics.
2. The clinical implication of these results indicates that the *Elgiloy* archwire might be the optimum choice for construction of lingual arch space maintainers. Heat treatment may enhance stability of this wire.  $\beta$ -Titanium may be another good option.
3. Heat treatment has not been shown as a procedure essential to attain favourable stability in lingual archwires.
4. However, some benefits do accrue, for example, only very slight dimensional changes occur after the initial expansion response.
5. Should heat treatment be performed it would be proper that the archwire is readjusted to the correct form before clinical placement.
6. Even if lingual archwires, whether heat-treated or not, do expand it appears that the associated forces are of a level unlikely to effect tooth movement.
7. If the archwires do not undergo heat treatment the deleterious effect of metal ion release will be avoided.

## CHAPTER 6

### 6.0 REFERENCES

1. Hitchcock HP. Space maintainers and space regainers. In: Hitchcock HP, editor. Orthodontics for Undergraduates. Philadelphia: Lea & Febiger, 1974:248-73.
2. Burstone CJ, Manhartberger C. Precision lingual arches. Passive application. J Clin Orthod 1988;22(7):444-51.
3. Moyer RE. Development of dentition and occlusion. In: Moyer RE, editor. Handbook of Orthodontics. 3<sup>rd</sup> ed. Chicago: Year Book Medical Publishers, 1973:166-241.
4. Ghafari J. Early treatment of dental arch problems: I. Space maintenance, space regaining. Quintessence Int 1986;17:423-32.
5. Moyer RE. Early treatment. In: Moyer RE, editor. Handbook of Orthodontics. 4<sup>th</sup> ed. Chicago: Year Book Medical Publishers, 1988:343-431.
6. Woodward GL, Leake JL. The use of space maintainers in the North York Public Dental Program. Community Dental Health Research Unit. Quality Assurance Report No.4. 1993.
7. Rebellato J, Lindauer SJ, Rubenstein LK, Isaacson RJ, Davidovitch M, Vroom K. Lower arch perimeter preservation using the lingual arch. Am J Orthod & Dentofacial Orthop 1997;112(4):449-56.

8. Proffit WR. Treatment of nonskeletal problems in preadolescent children. In: Proffit WR, Fields HW, editors. *Contemporary Orthodontics*. 2<sup>nd</sup> ed. St Louis: Mosby, 1993:376-82.
9. Singer J. The effect of the passive lingual archwire on the lower denture. *Angle Orthodontist* 1974;44:146-55.
10. McDonald RE, Hennon DK, Avery DR. Managing space problems. In: McDonald RE, Avery DR, editors. *Dentistry for the Child and Adolescent*. 5<sup>th</sup> ed. St Louis: Mosby, 1987:721-49.
11. Goldberg AJ, Burnstone CJ. An evaluation of beta titanium alloys for use in orthodontic appliances. *J Dent Res* 1979;58:593-600.
12. Andreasen GF, Morrow RE. Laboratory and clinical analysis of nitinol wire. *Am J Orthod* 1978;73:142-51.
13. Burnstone CJ, Goldberg AJ. Beta titanium: A new orthodontic alloy. *Am J Orthod* 1980;77(2):121-32.
14. Proffit WR. Mechanical principles in orthodontic force control. In: Proffit WR, Fields HW, editors. *Contemporary Orthodontics*. 2<sup>nd</sup> ed. St Louis: Mosby, 1993:289-315.
15. Adams PE. Labial technique. In: Graber TM, editor. *Current Orthodontic Concepts and Techniques*. Philadelphia: Saunders, 1969:275-346.
16. Asgharnia MK, Brantley WA. Comparison of bending and tension test for orthodontic wires. *Am J Orthod* 1986;89(3):228-36.

17. Kapila S, Sachdeva R. Mechanical properties and clinical application of orthodontic wires. *Am J Orthod* 1989;96:100-9.
18. Larson BE, Kusy RP, Whitley JQ. Torsional elastic property measurements of selected orthodontic arch wires. *Clin Mater* 1987;2:165-79.
19. Burstone CJ, Koenig HA. Precision adjustment of the transpalatal lingual arch: Computer arch form predetermination. *Am J Orthod* 1981;79:115-33.
20. Thurow RD. Orthodontic metals-hardening and heat treatment. In : Thurow RD, editor. *Edgewise orthodontics*. 4<sup>th</sup> Ed., St Louis: Mosby, 1972, 43-46.
21. Howe GL, Greener EH, Crimmins DS. Mechanical properties and stress relief of stainless steel orthodontic wire. *Angle Orthod* 1968;38:244-9.
22. Khier SE, Brantley WA, Fournelle RA. Structure and mechanical properties of as-received and heat treated stainless steel orthodontic wires. *Am J Orthod Dentofacial Orthop* 1988;93(3):206-12.
23. Marcotte MR. Optimum time and temperature for stress relief treatment of stainless steel wire. *J Dent Res* 1973;52:1171-75.
24. Durr DP, Vargas R, Ward K. Evaluation of stress-relief methods on cobalt-chromium orthodontic wires. *J Dent Res* 1986;65:(abstr) 228.
25. Fillmore GF, Tomlinson JL. Heat treatment of cobalt-chromium alloy wire. *Angle Orthodontist* 1976;46:187-95.

26. Gjerdet NR. Clinical and biological aspects of orthodontic materials. In: Mjor IA, ed. *Dental materials: biological properties and clinical evaluations*. Boca Raton, Florida, USA: CRC Press, 1985:165-76.
27. Gjerdet NR, Her H. Metal release from heat-treated orthodontic archwires. *Acta Odontol Scand* 1987;45(5):409-14.
28. Howes VR. Oxide growth and spalling on Fe-Cr alloys studied by hot stage microscopy. *Corr Sci* 1968;8:729-36.
29. von Fraunhofer JA. *Concise Corrosion Science*. London: Portucullis Press, 1974:35-9.
30. Hazel RJ, Rohan CJ, West VC. Force relaxation in orthodontic arch wires. *Am J Orthod* 1984;86(5):396-402.
31. Kusy RP. A review of contemporary archwires: Their properties and characteristics. *The Angle Orthodontist* 1997;67(3):197-203.
32. Hitchcock HP. Preventive orthodontics. In: Finn SB, editor. *Clinical Pedodontics*. 4<sup>th</sup> ed., Philadelphia: Saunders, 1973:342-69.
33. Nagatani SS, Fisher JG, Hondrum SO. Effect of heat treatment on stainless steel lingual arch appliances. *ASDC J Dent Child* 1996;63(5):346-9.
34. Nance HN. The limitation of orthodontic treatment: II, diagnosis and treatment in the permanent dentition. *Am J Orthod* 1947;33:253-8.

35. Björk A, Skieller V. Facial development and tooth eruption: an implant study at the age of puberty. *Am J Orthod* 1972;62(4):339-83.
36. Backofen WE, Gales GF. Heat treating stainless steel for orthodontics. *Am J Orthod* 1952;38:755-65.
37. Hill CJ, Sorenson HW, Mink JR. Space maintenance in a child dental care program. *JADA* 1975;90:811-5.
38. Baroni C, Franchini A, Rimondini L. Survival of different types of space maintainers. *Pediatr Dent* 1994;16:360-61.
39. Williams JK, Cook PA, Isaacson KG, Thom AR. Force magnitude and anchorage value. In: Williams JK, Cook PA, Isaacson KG, Thom AR, editors. *Fixed orthodontic appliances. Principles and practice*. 1<sup>st</sup> ed. Philadelphia: Wright, 1995:8-9.
40. Ackerman JL, Cohen J, Cohen MI. The effects of quantified pressures on bone. *Am J Orthod* 1966;52:34-9.
41. Weinstein S. Minimal forces in tooth movement. *Am J Orthod* 1967;53:881-903.

**Author** Cheshankova-Kostova E L

**Name of thesis** Stability Of Stainless Steel (Ss), Cobaltcrome (Co/Cr) And B-Titanium Lingual Archwires Cheshankova-Kostova E L 1999

***PUBLISHER:***

University of the Witwatersrand, Johannesburg

©2013

***LEGAL NOTICES:***

**Copyright Notice:** All materials on the University of the Witwatersrand, Johannesburg Library website are protected by South African copyright law and may not be distributed, transmitted, displayed, or otherwise published in any format, without the prior written permission of the copyright owner.

**Disclaimer and Terms of Use:** Provided that you maintain all copyright and other notices contained therein, you may download material (one machine readable copy and one print copy per page) for your personal and/or educational non-commercial use only.

The University of the Witwatersrand, Johannesburg, is not responsible for any errors or omissions and excludes any and all liability for any errors in or omissions from the information on the Library website.