

MINE SURVEYING IN GHANA: A FRAMEWORK FOR COMPLIANCE

Colin Maltby Bennett

A research report submitted to the Faculty of Engineering and the Built Environment, of the University of the Witwatersrand, in the partial fulfilment of the requirements for, the degree of Master of Science (50/50) in Engineering.

Johannesburg, 2012

DECLARATION

I declare that this research report is my own unaided work. It is being submitted in partial fulfilment of the Master of Science, to the University of the Witwatersrand, Johannesburg. It has not been submitted before for any degree or examination to any other University.

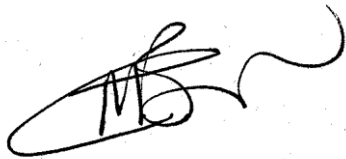

.....
(Signature of Candidate)

.....18th..... day ofApril..... year2012.....

ABSTRACT

In response to the request to research government rules and regulations that are relative to Mine Survey and could impact on global mining companies in different countries in Africa, a framework has been established to assist and support many companies working in these countries. The framework guides investigations in determining the legal risks to the Company in general and Mine Surveying in particular. Legally appointed personnel fall directly under this risk profile. Furthermore, the primary activities and overlying acts and regulations form workable matrices to address all areas of compliance and risk within the Mine Surveying areas of responsibility. The framework takes into account the supporting activities which operate within the acts and regulations. These departments are generally not directly accountable to the legislation, but form part of the mining value chain and depend on Mine Surveying results and service. It is therefore appropriate that the investigation into the international component of the framework was conducted as well. The links to international codes and practices were established with special reference to Mine Surveying association and participation. The mining process was researched in its entirety. It was found that there are numerous government departments and associated laws prescribing compliance for Mine Surveyors. The framework describes the various levels of work so that all risk to people, property and equipment is tabled and applicable working standards and guidelines are put in place to mitigate such risk. A uniform standard can guide all Mine Surveyors in establishing the Survey Manual. This manual of standards drives levels of accuracy and therefore training and development of the individual Mine Surveyor. The major finding was that Mine Survey cannot be researched alone as it interfaces with several other mining departments, legal structures and possible international codes. This research has reported on the Ghanaian portion of a global mining company. The Company's business units in other countries have been benchmarked as well. South African based mining companies have strong Mine Survey structures, while in countries such as Canada and Australia, Mine Surveying is a sub section of Engineering. Would the next research be on a different continent?

ACKNOWLEDGEMENTS

I would like to thank Prof Fredrick Cawood and Alexander Bals for the valuable advice they gave to me during the preparation of this research and report. Also thanks to Moira, my patient, understanding wife, who supported me throughout the research.

CONTENTS	Page
DECLARATION	1
ABSTRACT	2
ACKNOWLEDGEMENTS	3
LIST OF FIGURES	6
LIST OF TABLES	7
1 INTRODUCTION	8
1.1 The significance of the topic.....	8
1.2 Preview of the organisation of the research paper	10
1.2.1 General background to Ghana	11
1.3 Summarise aims of the literature research	13
1.3.1 Possible constraints	15
1.3.2 Proposed solution to the problem	16
1.4 Summary of findings and statement of current knowledge	17
1.4.1 What is known about the topic - Production of the system	17
1.4.2 Research and review summary to date.....	18
1.4.3 Significance of the study.....	19
1.5 Conclusion	20
2 THE LEGISLATION FRAMEWORK IN GHANA.....	21
2.1 Introduction.....	21
2.2 Review of relevant work.....	22
2.3 Relevant Acts and Regulations	23
2.4 The Ghanaian hierarchy and overlying components	28
2.5 Outcome from the research and reviews.....	29
2.6 Review of other departments and commissions influencing mining in Ghana	32
2.7 Conclusion	33
3 METHODOLOGY, REVIEW AND ANALYSIS.	34
3.1 Overview of the contents of the literature review	34
3.2 Methodology	35
3.3 Relative institutions with key references	36
3.4 The country specific regulatory framework for mining.....	39
3.5 Review of the Mining Regulations 1970	45
3.6 Key extracts from the Mining Regulations 1970.....	45
3.7 Recommendations.....	52
3.8 Conclusion	54
4 DESIGN AND STRUCTURE OF THE FRAMEWORK.....	56
4.1 The Mining Value Chain	56
4.1.1 Primary Activities	56
4.1.2 Supporting Activities	56
4.2 Mine Surveying integration	57
4.3 Key extracts from the standard instructions document for mine surveying	58

4.4	Design framework for risk log and legal adherence to the various laws influencing the Mine	68
4.5	Construction of the framework	69
4.6	Chief Surveyors key performance indicators.....	72
4.7	Conclusion and recommendation.....	74
5	IMPLEMENTATION AND TESTING OF THE SURVEY FRAMEWORK TABLES	75
5.1	Establish a Gap Analysis for the Survey discipline	75
5.2	Process flow	77
5.3	Correspondence review and feedback	78
5.4	On Mine guideline comparisons	83
5.5	Assurance and Audit	85
5.6	The levels of work in the Survey section.....	86
5.7	Individual Capability	88
5.8	Abridged CV	88
5.9	Individual Profile	89
5.10	Succession planning template	89
5.11	Summary of the Proposed Company’s Survey guidelines.....	90
5.12	Closing	90
6	SUMMARY, RECOMMENDATION AND CONCLUSION	92
6.1	Summary	92
6.1.1	Process for literature review	92
6.1.2	Mine Survey integration	93
6.1.3	Risk log	93
6.1.4	The Country Register	93
6.1.5	Key performance indicators for Chief Surveyors	93
6.1.6	Mine guidelines comparisons	94
6.1.7	Summary of the proposed Company guidelines	94
6.1.8	Appendix with a proposed code of practice for the Company.....	95
6.2	Recommendations.....	95
6.3	The Survey manual	96
6.4	Conclusion	97
	REFERENCE.....	101
	APPENDIX A MINE SURVEY GUIDELINES	103
	APPENDIX B TEMPLATES	116

LIST OF FIGURES

Figure 1.1	Brown Paper Exercise.....	14
Figure 1.2	High Level Structuring	16
Figure 1.3	Mineral and Mining Flow	20
Figure 2.1	Code of practice	26
Figure 2.2	Mission statement	26
Figure 2.3	General requirements for mine plans and surveys.....	27
Figure 2.4	Extract from Chapter 17	28
Figure 2.5	The overlying governing components	29
Figure 2.6	Minerals and Mining Departments	30
Figure 2.7	Mining Value Chain – underlying codes and guidelines.....	31
Figure 2.8	Country Legislation Register	32
Figure 3.1	Flow of legislation in Government	34
Figure 3.2	Legislation levels relative to Mining Survey.....	35
Figure 3.3	Example of the research methodology	36
Figure 3.4	Topographic/Cadastral for Cape Town.....	43
Figure 3.5	Cadastral available to the public through Government	44
Figure 4.1	Primary Activities	56
Figure 4.2	Supporting Activities	57
Figure 4.3	Example of guideline sketches	60
Figure 5.1	The Process flow.....	77
Figure 5.2	The work load route.....	78
Figure 5.3	Assurance template	85
Figure 5.4	Assurance graph.....	86
Figure 5.5	Abridged CV.....	88
Figure 5.6	Individual profile	89
Figure 5.7	Succession plan template	90
Figure 6.1	Literature flow	92
Figure 6.2	International research chart.....	98
Figure 6.3	Country specific research chart	98
Figure 6.4	Mining Regulations research chart	99
Figure 6.5	A view of the total implementation timeline	99

LIST OF TABLES

Table 1.1	Framework in relation to time.....	10
Table 1.2	Structure for research paper	11
Table 3.1	Key words and phrases	37
Table 3.2	Survey related action to be taken	40
Table 3.3	Survey related action to be taken - continued.....	42
Table 4.1	Service and calibration register.....	61
Table 4.2	Survey procedure	63
Table 4.3	Example of: - Part 1: Sinking - Planning the Work	65
Table 4.4	Part 1: Sinking - Carry out the work.....	66
Table 4.5	Part 2 Equipping - Planning the Work.....	67
Table 4.6	Part 2: Equipping - Carry out the work.....	67
Table 4.7	Pack, transport and exit.....	68
Table 4.8	Risk log	69
Table 4.9	International Register and Framework.....	70
Table 4.10	Country Register	71
Table 4.11	Key Performance Indicators.....	73
Table 5.1	Current “on mine” guidelines	84
Table 5.2	Survey Planner Model.....	87

1 INTRODUCTION

1.1 The significance of the topic

There is a major concern with respect to safety, health and business risk amongst senior mining managers who operate in several African countries. The focus is on legal compliance in different countries, with general reference to mining and specific reference to Mine Surveying. Legislation, codes of practice, standards and guidelines differ from country to country. Of greater concern is the risk attached to individuals and companies when there are disparities between these acts and regulations.

This is a significant topic which has elevated attention across the continent.

The following quotation is an extract from the document Africa Mining Vision (AMV, 2009) published in February 2009. *“-there is need to expedite intra-regional harmonization of laws, regulations and fiscal regimes, among other critical factors”* The continuous references to mineral resource codes as guidelines for all companies across the globe is definite proof that other codes and standards will eventually become applicable across borders in Africa.

The reference to framework in the extract below has similar components to this research philosophy. The Mine Survey framework for compliance in Africa as a continent will align with the greater vision for mining in Africa. *In February 2004, thirty African mining ministers and/or their representatives launched the African Mining Partnership (AMP), with the aim of championing and coordinating mining and mineral-related initiatives under the auspices of NEPAD¹. “AMP’s current efforts to formulate the African Mining Policy Framework and the Sustainable Development Charter for Africa’s Minerals and Mining Sector are of key relevance to mineral policy formulation on the continent.”* (AMV, 2009).

Chapter 1 gives a general introduction to the topic and to Ghana. It also establishes the new goals and boundaries of the research.

¹ The New Partnership for Africa’s Development

Chapter 2 will take the form of a literature review, which examines the mineral and mining legal structure in Ghana. A review of other departments and commissions influencing mining in Ghana is conducted, together with the international relationships and compliance. AngloGold Ashanti (AGA) and their view on the legal requirements and compliance within Ghana will be discussed.

Chapter 3 will contain methodology, review and analysis. The relative institutions, with key references will be studied; focussing on the key extracts from the Minerals and Mining Acts, as well as the Mining Regulations 1970.

Chapter 4 will deal with the design and structure of the framework. The Mining value chain will show the primary activities that will influence the research as well as the supporting activities that may or may not require research. The overall integration of Mine Survey in the construction, operation and closure of a mine needs review. The research shows key extracts that will influence the compliance of the Survey section and the mine. A preliminary template will explain the first steps in determining any gaps and associated risks. An additional checklist for the Chief Surveyor² will prompt the necessary literature review and highlight areas of concern.

Chapter 5 will comprise the testing phase of the guideline for compliance, together with the initial response from the mines. The “on mine” standards are reviewed and suggestions are offered. Self auditing can be done with the proposed set of tables created for assurance for the Survey section. The various classes of survey, which are driven by required accuracies, will also influence the levels of work within the Survey section. A framework describing levels of work is also discussed. Knowing the levels of work required, the individual capabilities are determined which in turn populates training and development. Succession planning can now be undertaken.

Chapter 6 will summarise the research with recommendations and conclusions.

² Chief Surveyor is a common but old reference to the competent person in a survey section. Some countries and mining houses might use different terms. Therefore the qualification and appointment becomes important.

Table 1.1 is an extract from the African Mining Partnership (AMP 2009) to illustrate the framework in relation to time, set out for the specific actions.

Table 1.1 Framework in relation to time

<u>2. TERM SPECIFIC ACTIONS</u>			
<u>Objectives</u>	<u>Related Actions</u>		
	<u>Country-Level</u>	<u>RECs Level</u>	<u>Continent-Wide</u>
<u>Short Term (< 5 years)</u>			
Promote Natural Resources Governance (Manage stakeholders' engagement throughout the mine life cycle; Improve management of transfer payments)	Mainstream EITI ³ principles and the Kimberly Process Certification Scheme ⁴ in national policies, laws, and regulations; encourage establishment of national oversight bodies and implicate parliamentarians and independent committees in the monitoring of mining projects; consider decentralization of mineral revenue distribution; build capacity to manage mineral revenue of national and sub-national institutions	To speed up harmonization processes at sub-regional level	Include a natural resources chapter into the APRM ⁵ .
Foster inter-generational equity	Consider the use of Future Generation Funds and Stabilization Funds; integrate mining in national development plans and poverty reduction strategies.		

(AMV, 2009)

1.2 Preview of the organisation of the research paper

It is important to table a structure for the coordination of the research and report. In column three of Table 1.2 the structured paragraph content is listed and the amended and revised chapter content is then tabled in column four.

³ Extractive Industries Transparency Initiative

⁴ Kimberley Process for diamonds certification.

⁵ Africa Peer Review Mechanism

Table 1.2 shows the preliminary organisation.

Table 1.2 Structure for research paper

<u>Dissertation Structure for a Design and Build Project</u>	<u>Proposal - Tentative outline</u>	<u>Actual chapter content and description</u>	<u>Revised chapter content and description</u>
Chapter 1: Introduction	The overview of Ghana	Chapter 1: Introduction <ul style="list-style-type: none"> • Overview • Background • Standardisation • The journey • Political overview • Ghana's Statistics • The AngloGold Ashanti and Ghana association • AGA Mining properties • The chapters that follow 	Chapter 1: Introduction <ul style="list-style-type: none"> • Background information • Aims and objectives • Possible constraints • Proposed solution to the problem • Production of the system • The chapters that follow will include
Chapter 2: Literature Review	Literature research of the mineral and mining legal structure in Ghana Review of other departments and commissions influencing mining in Ghana	Chapter 2: Literature Review (Part 1 and 2 from Mine Surveying in Ghana.doc) <ul style="list-style-type: none"> • Introduction to the review. Literature research of the mineral and mining legal structure in Ghana	Chapter 2: Literature Review <ul style="list-style-type: none"> • Overview of the contents of the literature review • Review of relevant work by other authors and published documents • The relevant acts and regulations.

1.2.1 General background to Ghana

Ghana lies along the Gulf of Guinea in West Africa and is divided into ten regions. A relatively flat topography depicts more than half the country, with the highest mountain at only 880m (Mt. Afadjato). Portuguese navigators were the first Europeans to establish trade in gold and slaves in the 15th century. The British established the Gold Coast after the defeat of the Ashanti Kingdom in the late 19th century. (Mining Journal, 2010).

Independence was achieved in 1957. The country is currently under a stable democratic dispensation, led by the National Democratic Congress (NDC). President John Evans Atta Mills was elected in 2009.

To set the scene and update Ghana's political views with respect to minerals, selected portions of an extract quoting the Minister of Lands and Natural Resources, is tabled.

“I wish to welcome you on behalf of His Excellency Professor John Evans Atta-Mills, President of the Republic of Ghana, the government and the friendly people of Ghana to the investment gateway to the West Africa sub-region. For the first time in the history of the country, high-resolution airborne data, made up of magnetic and radiometric information, covering the whole country is now available. Indeed, the recently completed Mining Sector Support Programme, funded by the European Commission, has led to the discovery of minerals apart from the traditional minerals (gold, diamond, manganese and bauxite) which are produced in Ghana”. (Dauda, 2010).

The merger in April 2004 was preceded by AngloGold and the government of Ghana agreeing to the terms of stability to govern certain aspects of the fiscal and regulatory framework under which AngloGold Ashanti would operate in Ghana.

Under the stability agreement (AGA, Obuasi Country report 2008), the government of Ghana agreed to extend mining leases to 2054, as well as to maintain royalties at 3% for a further 15 years. They also agreed to keep the income tax rate at 30% for 15 years, while the sale of AGA or subsidiaries remained subject to Government approval.

The current mining lease for the Obuasi was granted by the Government of Ghana on 5 March 1994. The mining right has an area of approximately 334 square kilometres in the Amansie East and Adansi West districts. This is in the Ashanti region where the application for a mining lease over the adjacent 140 square kilometres has also been granted. The Company is required to pay rent to the Government of Ghana at a rate of approximately \$5 per square kilometre. The mining lease was formally ratified by Parliament on 23 October 2008.

Iduapriem has a mining lease granted on an area of 33 square kilometres, awarded on 19 April 1989 for a period of 30 years. The terms and conditions of the lease are consistent with similar leases granted in respect of the Obuasi mining lease.

Teberebie has two leases, one granted in February 1998 for a term of 30 years, and another granted in June 1992 for a term of 26 years.

1.3 Summarise aims of the literature research

As the research progressed in the compilation of the “Africa Register⁶”, it became apparent that tackling all the mines would be a challenge. There was certainly a need to focus on Ghana and Mali in the short term. After several reviews and meetings the directive was to deal with Ghana as the immediate target. However, the resultant output should form the basis of a framework that AGA could use on all the other mines to expedite the process. In due course the framework must be re-engineered to form an Africa Framework for Survey Assurance. To address the issue of “*the risk attached to individuals and companies*” and in response to the request to research government rules and regulations that impact on global mining companies in different countries in Africa, a framework will be established to assist and support the companies working in these countries. The first and most important “port of call” will be the research and study of the current and legislated mining related law in Ghana.

Adherence to all these regulations and acts is paramount for the benefit of individuals and the Company. In conjunction with this research, a register matrix will be initiated, possibly as a “brown paper⁷” exercise.

⁶ “Africa Register” relates to the comparison of mining legislation review across the continent.

⁷ The brown paper exercise was a physical table on a sheet of brown paper.



Figure 1.1 Brown Paper Exercise

The visual assistance of this will give the broader view on the legislation in Ghana. The extracts relating to Mine Survey in all the researched material will be used to populate a data base for comparison to actual adherence. A gap analysis will follow, with a risk log highlighting any need to enhance or mitigate risk to the owner and managers. Where the Company deems it necessary to introduce supporting guidelines and codes, the best in practice should be found and introduced. Ultimately an “All Africa Register” would be available, initially as a blue print with a final publication.

The analysis of the framework will guide investigations in determining the legal risks to the Company and its personnel. Furthermore, the primary activities and overlying acts and regulations must form workable matrices to address all areas of compliance and risk. From the analysis a natural flow of work, appointments and competencies will emerge. This can be an enhancement to the Company in legal appointments, relative qualifications, together with associated training and development. From this, individual development programs will become apparent.

The framework must also take into account the supporting activities which operate within the acts and regulations but are not directly accountable to the legislation departments. It is therefore appropriate to investigate the international component of the framework as well. The links to international codes and practices will be established with special reference to “association to” and “participation in”.

The mining process will be researched in its entirety as there are many different governmental departments and associated laws prescribing compliance. There are subtle links to Mine Survey and these links must be tabled. The framework will unfold to the various levels of work so that all risk to people, property and equipment is tabled and applicable working standards and guidelines are put in place to mitigate such risk.

The framework will cater for best in practice in Africa, rather than country specific. The reason behind this focus is to have a blue print that will fit all the Company's operations in the various countries in Africa. Where responsibility or guidelines are not required by law, the compliance or accommodation of codes of practice and standards may support civil components of accidents or incidents.

The modus operandi will be to take several countries into account and make detailed comparisons to produce the blue print framework required for a company.

1.3.1 Possible constraints

The chronological and related limitations are constrained to 2010 and 2011, which is when the research began, as well as cognisance of when legal and gazetted acts were made. The dates are crucial when quoting acts and amendments, so this must be shared with all interested parties. The knowledge that a regulation is being reviewed and will replace an old act must not influence the research. The gazetted act or regulation is final. In contrast, if the owner is quoted as being responsible in a wider definition, it would be to the Company's benefit to draft and table guidelines as, and when they felt the need.

If the basic survey functions and standards are the same across the world, the Company's risk profile will be reduced. Standards, technology, funding and people comprise a set of variables that influence the process and outcome of surveying at any workplace, regardless of the country in which the Company operates. Some legislation describes the responsibilities of individuals or owners very clearly, but in most cases the owner ultimately carries all the risk. The

common practice of delegating some of this responsibility to competent subordinates is a method of reducing risk and sharing the load. The maps required for environmental studies are the responsibility of the owner. The content is acquired by the resident environmental person while the accuracy and compliance of the plan is the responsibility of the competent Mine Surveyor.

1.3.2 Proposed solution to the problem

A “high level structure⁸” was accomplished, emanating from a brown paper exercise to categorise the work to be performed.

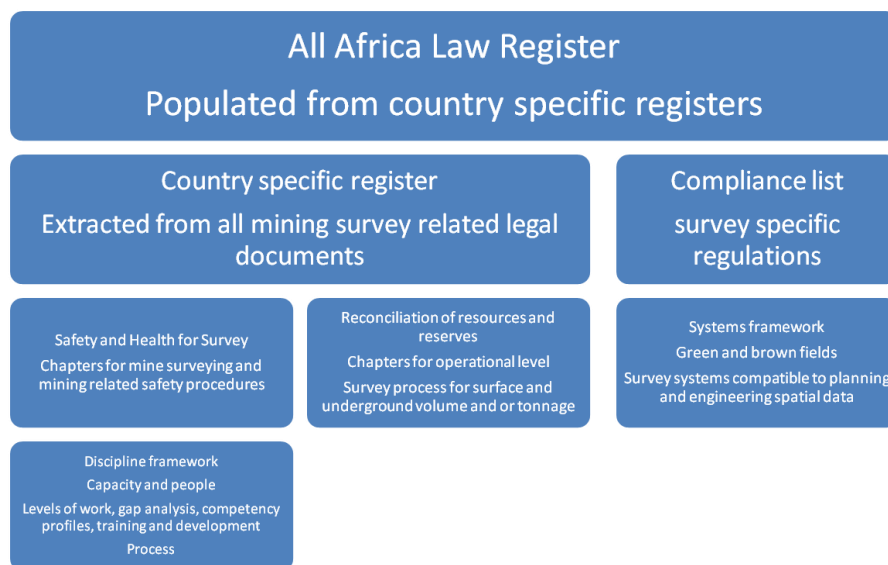

Figure 1.2 High Level Structuring

There are many supporting activities which bring additional codes and guidelines into the process and management of mining. Adding to the supporting activities are several overlying primary activities which influence the mining acquisition, process and beneficiation.

The interesting phenomenon in this topic is the variation of technology that is available and how it influences regulations and standards across the continent.

⁸ “high level structure” shows the legal requirements/compliances at various levels relevant to Mine Survey

The old technical process of mine surveying is essential to all the primary and supporting activities in mining. This “scientific art⁹” is often the result of solving the right angle triangle, but is in fact the foundation for planning and mining. Surveying has the resultant outcome of spatial data encapsulate, future design scenarios tabled and infrastructure captured. The result of this study will be to populate a risk log and produce the next steps to close the gap between the variation in technology and the implemented regulations and standards, which could bring some level of assurance to managers and owners that the business risks are adequately managed. This research will attempt to answer the following questions:

Are the relative codes and guidelines all reviewed and understood?

Is there a thread linking the resultant activities into a logical hierarchy and appointment structure?

Some international codes and regulations need to be taken cognisance of for an overall perspective.

1.4 Summary of findings and statement of current knowledge

The next three points will table what is known about the topic, summarise the literature review and state the significance of the review.

1.4.1 What is known about the topic - Production of the system

AGA tabled the need for a framework solution for mine surveying across Africa. Mine surveying is unquestionably a source of information for managing safety and risk in all mining methods and situations. The initial task was to analyse and compare the survey compliance for the African AGA Mines.

⁹ “scientific art” refers to the mine surveying profession where skills are fondly stated as being an art

Senior managers and surveyors have shown interest in the standardising of the guidelines and therefore, the processes. Both parties carry responsibilities for safety and health. Legal appointments and compliance to acts and regulations are often performed only within the stipulated text. There might be little regard for best in practice or “the reasonable person¹⁰” test theory. One would expect the legislative departments and associated sections to be interested in this research and the resultant framework. Legislative departments’ frameworks are often at a high level and give insight and guidance in the broader perspective of the mining value chain. They would rely on the owner to appoint managers and competent supervisors. It is interesting to note the current interest shown by the academics and certain learning institutions.

1.4.2 Research and review summary to date

The following has been researched and reviewed:

- Mining legislation of Ghana
 - Minerals Act
 - Mining Regulations
 - Survey Regulations
 - Safety and health
 - Minerals Commission
 - Inspectorate division

- Acquisition codes and regulations
 - Prospecting and mining rights
 - Environmental Acts
 - Social and labour plans

- Local and customary rules and regulations
 - Ghana’s King

¹⁰ “the reasonable person” refers to risk assessment and the common law theory where people need always have legal reference but where common sense prevails

- Ghana's people
- Ghana's environment

- International codes and guidelines
 - European Union guidelines
 - International labour organisation
 - International standards organisation

- Monetary and beneficiation codes
 - Stock Exchange rules
 - Financial accounting rules
 - Taxation and royalties

- Minerals classification and reconciliation rules
 - SamRec¹¹ and SamVal¹² codification
 - Jorc¹³ code of practice
 - Ore accounting principles

1.4.3 Significance of the study

To approach the legal compliance study for mining in Ghana, the research will be looking to ensure that all responsibilities are listed, so as to table a framework for compliance. This would require a special methodology as the study cannot be restricted to Mine Survey regulations and guidelines only. The legislative network moving upwards from the mining activities must be tracked and recorded. The resultant data will help to populate the framework and matrix. All legislation that has an influence in the mining value chain will need to be studied and recorded. From prospecting and acquisition of mines, through to beneficiation of the product and including the closure of the mine, the impact should be noted and the risk log populated. The early work completed in

¹¹ South African Code for Reporting of Exploration Results, Mineral Resources and Mineral Reserves

¹² South African Code for the Reporting of Mineral Asset Valuation

¹³ The Australasian Joint Ore Reserves Committee

preparation for the research is shown in Figure 1.3. Again, the visual version of the research assists in the compilation of the planned framework for Survey.

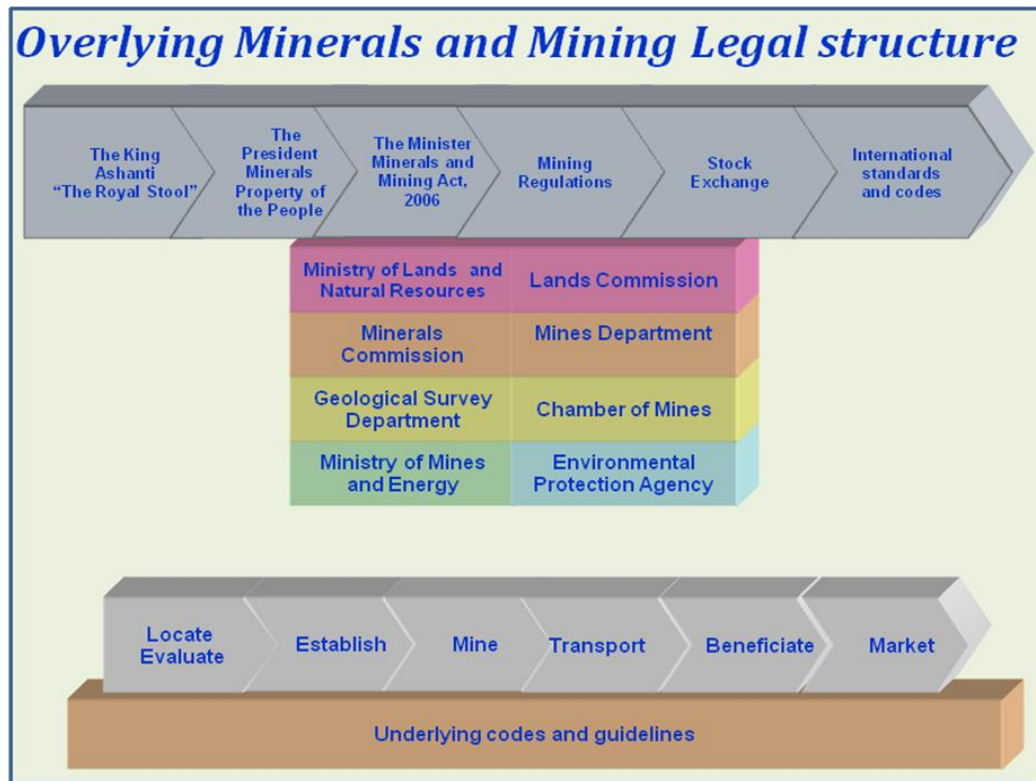

Figure 1.3 Mineral and Mining Flow

1.5 Conclusion

This chapter gave an introduction to the topic and to Ghana. It demonstrated that the area of interest required research and review to illustrate either compliance or non-compliance. The major finding was that mine survey cannot be researched alone as it interfaces with several other mining departments, legal structures and possible international codes. The next chapter will explain the literature review in some detail. This is necessary to demonstrate the multi-faceted and complex nature of the mining legal register.

2 THE LEGISLATION FRAMEWORK IN GHANA

2.1 Introduction

Chapter 1 gave an introduction to the topic and to Ghana. It demonstrated that the area of interest required research and review to illustrate compliance or non-compliance to the legal framework across several areas within in the mining fraternity.

This chapter provides an overview of the literature and current knowledge relevant to the topic. The purpose of the literature review is to create a firm foundation for advancing the author's knowledge of legislation in Ghana. The research and literature review will not be limited to the management level, but will be filtered to the lowest competent level defined by the study.

It is essential to demonstrate an understanding of the literature so as to identify gaps that may carry a business risk for AGA. The research document will have the benefit of the knowledge gained from extensive involvement in regulations in Southern African countries (Mine Health and Safety Act) in that parallels can be drawn and comparisons made. Previous studies and qualifications in mining regulations add additional understanding of the literature. A special relationship with the local authorities in mine surveying has developed over time.

A country wide application for renewal of mining rights in South Africa was recently regulated, where old order rights needed to be changed to new mining rights. This process introduced mining personnel to “supporting legislation¹⁴” and made them aware of the risks, which were not blatantly obvious or fully understood in the old law. Mine Works Plans¹⁵, together with Social and Labour Plans required input from Survey; for example; revisiting mining right boundaries for clarification and accuracy. Legislation prescribes appointments required in the mining environment and therefore a special mention must be made of the appointment hierarchy learning's that were acquired. Incorrect interpretation of

¹⁴ Supporting refers to legislation other than mining but still influencing the company.

¹⁵ Mine Works Plans, as well as Social and Labour Plans are also required by the MPRDA in South Africa.

the appointment chain could lead to risk to AGA and legal issues in the future. This learning will be taken forward in the Ghana research and will be discussed in Chapters 2 and 3.

With global mining houses opening operations in African countries, a better understanding of the local laws and regulations is required. The research framework which will emerge will be transferable to other countries and adjusted as and when necessary. This philosophy originates from the fact that mine surveying across the world has similar basic activities. Even though the detailed input at the lower levels of work performed is crucial, the process and framework will highlight areas of risk and non-compliance at the higher levels of legislation and guidelines.

The rules of the ILO¹⁶ (International Labour Organisation) could possibly filter down and dictate to mining houses on mine working conditions.

Although this research will focus on survey issues in particular, the relevant adherence to minerals accounting from SamRec, influences mine surveying considerably. Guidelines for bills of quantities which are compiled by Surveyors are essential and populate the minerals accounting of the Mine and Company.

2.2 Review of relevant work

The initial research was done in the Mining Portal of Ghana (Mining Portal, 2010), a website outlining the departments involved, along with their vision and mission statements. The website is funded by the EU Mining Sector Support Programme to Ghana (European Union, 2010).

An overview by Mbendi (Mbendi, 2010), a worldwide mining website covering policies and regulations, was also researched. The structure of Ghana's mining and minerals law and the acquisition of rights are reviewed.

¹⁶ Constitution of the International Labour Organisation

The most recent information was found on the website of Infomine-Africa (Infomine, 2011). This carries the Mining Yearbook for 2010 and updates the reader on all aspects of Ghana with special emphasis on mining.

Anglogold Ashanti have Country Reports (AGA, 2010) for both of their operating mines in Ghana, namely Iduapriem and Obuasi. These reports give insight into the Company's adherence to country legislation, specifically mining and minerals.

2.3 Relevant Acts and Regulations

The research leads the way to a more focussed approach as relevant acts and regulations are examined. From a study of the Ghana Minerals and Mining Act, 2006 Act 703 (Minerals and Mining Act, 2010), relevant extracts will be tabled to highlight the areas in which the mine must comply with the Act. The research will not only table prescriptive portions of the Act, but will also present best practice and identify risks. A special effort was made to emphasise Mine Survey related regulations with examples listed below. These points will be dealt with individually in Chapter 3.

- *"The establishment and operation of a mining cadastre"* – although no responsibility is listed, this extract implies a complex and accurate plan of the mine.
- *"The returns to be rendered in relation to accounts, books and plans required to be kept by holders"* – although this initially could be deemed to be the work and responsibility of accountants and financial disciplines, the reference to plans is obviously a Mine Surveyors work. More importantly is the vague mention of returns which implies the production results which in turn needs the Mine Surveyors' month end results. When this function is investigated thoroughly, the full spectrum of the need for Mineral Resource Management is evident.
- *"The nature and adequacy of a map or plan required for the purpose of this Act"* – this regulation is open to debate but in the interest of the

Company and best practice, the plans will be kept up to date and as accurate as best practice requires.

- "*The protection of pits, shafts and other dangerous places*" – this mine surveying responsibility is also not stated but the Surveyor's role is embedded and the codes and guidelines for reduction in risk and safety is a big task.
- "*The reporting of accidents*" – Mine Surveyors are always part of the investigation and normally deliver the appropriate plans and sections as required by the Inspectorate.
- "*Ensuring the safety of the public and the safety and welfare of persons employed in mines*" – this is an all encompassing regulation that must be treated with the full respect of the intended results but also ensuring that all responsible company employees are aware of the possible risks and have all the necessary on mine codes and guidelines to cover any event.

The Mining Regulations of 1970 (Mining Regulations, 2010) has been researched. Even though this act is very old and the use of imperial measurement is of concern, there is an interesting chapter relevant to Mine Survey. A selection of the points is listed below:

- *The following plans shall be kept at every mine*
 - "*A general surface plan*" – normally a universally required plan for underground and surface mines. Infrastructure is often specified but not the survey systems and or associated spatial data.
 - "*An underground plan*" – always a prescribed plan for any underground workings. For the Mine Surveyor this requires the necessary accuracy including check surveys and gyroscope surveys in order to be confident of all working places on the mine.
 - "*The workings on each reef or mineral deposit shall be shown on a separate plan*" – the geological attributes applied to different reef horizons often result in different mining levels. This could be a difficult composite plan to read and to maintain, so separate plans are

value add to all disciplines. Suggested CADD¹⁷ solutions are described in the detailed review in the next chapter.

- *"An underground plan showing clearly the system of ventilation"* – this plan becomes a critical part in the event of any underground fire or rescue function. The day to day flow rates and directions are typically managed by the ventilation officials.
- *"Vertical projection or sections of the workings"* – underground workings that are mined on a dip are difficult to manage if the projection basics are not fully understood. The ore body, being almost vertical, is even more difficult to manage. Guidelines and training in producing and managing these plans are important.

Additional reviews on all the AngloGold Ashanti Mines in Africa were deemed to be a process of best practice. A specific focus on the regulations and survey standards and codes of practice were made to form the broader analysis and opinion.

- **Tanzania**

The focus of the research for the framework is not on Tanzania but the review indicates robust survey guidelines and standards. Important is the often mentioned issue of appointments and related responsibilities. Figure 2.1 and Figure 2.2 reflect the structure and hierarchy in this case study.

¹⁷ Computer aided draughting and design

ANGLOGOLD ASHANTI
GEITA GOLD

**CODE OF PRACTICE FOR MINE
SURVEYING/SURVEY STANDARDS FOR
MINE SURVEYING**

A copy of the Code of Practice required by this mine is enclosed herewith. You are required to familiarize yourself with the contents of this document and sign acknowledgement below

I hereby acknowledge that I have read the Geita Gold Mining Limited
Code of Practice for Mine
Surveying and fully understand the contents and implications thereof.

Technical Service Manager
I hereby acknowledge that I have read the Geita Gold Mining Limited
Code of Practice for Mine
Surveying and fully understand the contents and implications thereof.

Chief Mine Surveyor
I hereby acknowledge that I have read the Geita Gold Mining Limited
Code of Practice for Mine
Surveying and fully understand the contents and implications thereof.

Mine Surveyor

Figure 2.1 Code of practice

MISSION STATEMENT

Geita Gold Mine's strategic aim is to contribute to AngloGoldAsanti's purpose by developing Geita Gold Mining Limited into one of the world's most efficient, cost effective and safe gold mining operation through:

- Implementation of internationally recognized safe and environmentally friendly best survey practices.
- Maintaining cordial Survey relationships with the community and local government at both the regional and national level.
- Focused and open survey management principles.
- Development and training of high calibre and motivated survey employees.
- Use of latest proven technology and practices.

Figure 2.2 Mission statement

- **Namibia**

The mining regulations for Survey in Namibia have generally followed those of South Africa, as the country was previously part of the legislation and several mining houses had their head offices in Johannesburg. The

survey codes and guidelines are similar but not exactly the same, and are generally well regulated.

The extract in Figure 2.3 show survey regulations called "Part V mine plans and surveys and peg index registers".

General requirements relating to mine plans and surveys

5.5 (1) A peg index register and the plans required to be maintained under these regulations shall be kept available for inspection and maintained at every mine or at such other place as the Chief Inspector may permit.

(2) Where the Chief Inspector is of the opinion that any mine plan is not accurate or satisfactory, he or she may direct the mine manager by notice in writing to have a new plan prepared or a fresh survey made within such period as may be specified in such notice.

(3) Within 30 days after the cessation of mining operations, all prescribed plans and copies together with the peg index registers shall be handed in at the office of the Chief Inspector.

(4) A mine plan register shall be kept in the Chief Inspector's office.

Figure 2.3 General requirements for mine plans and surveys

- **South Africa**

The extract in Figure 2.4 refers to a competent person and then defines that competence, which is relevant to the Government certificates. This legal appointment is not the general practice across the continent and is discussed later in the research and review.

The responsibility is very clearly defined in South Africa.

<p>SCHEDULE</p> <p>CHAPTER 17</p> <p>SURVEYING, MAPPING AND MINE PLANS</p>	
17(1)	<p>DEFINITIONS</p> <p>In this Chapter, unless the context indicates otherwise-</p> <p><i>“bedded mineral deposit”</i> means any reef, coal seam, lode, mineral bed or fissure, which occurs conformably within it’s country rock and is not of a massive nature;</p> <p><i>“chart datum”</i> means the height referencing datum as determined by the Hydrographer of the South African Navy;</p> <p><i>“competent person”</i> means:</p> <p>(a) in the case of an underground mine or an opencast mine where blasting takes place, a person in possession of a Mine Surveyor’s Certificate of Competency issued by the Department of Minerals and Energy; or</p> <p style="padding-left: 40px;">a person in possession of at least a Level 6 qualification in mine surveying and mapping registered on the National Qualifications Framework and which qualification includes appropriate and relevant legal knowledge;</p> <p>(b) in the case of an opencast mine where blasting does not take place, a person in possession of a Mine Surveyor’s Certificate of Competency issued by the Department of Minerals and Energy; or</p> <p style="padding-left: 40px;">a person who has passed the examination for legal knowledge as is required for the Department’s Mine Surveyor’s Certificate of Competency and who is in possession of either –</p>

Figure 2.4 Extract from Chapter 17

2.4 The Ghanaian hierarchy and overlying components

As the understanding of Ghana’s legislation increases, a broader research is necessary in order to demonstrate the links upwards from the Minerals Act and downwards to the mining activities. Follow-up meetings were held with AGA (2010) and confirmed the hierarchy, including the traditional component. The King is a traditional and integral part of the country. The minerals of the country are vested in the president, in trust for the people. Figure 2.5 shows the hierarchy of Ghana.

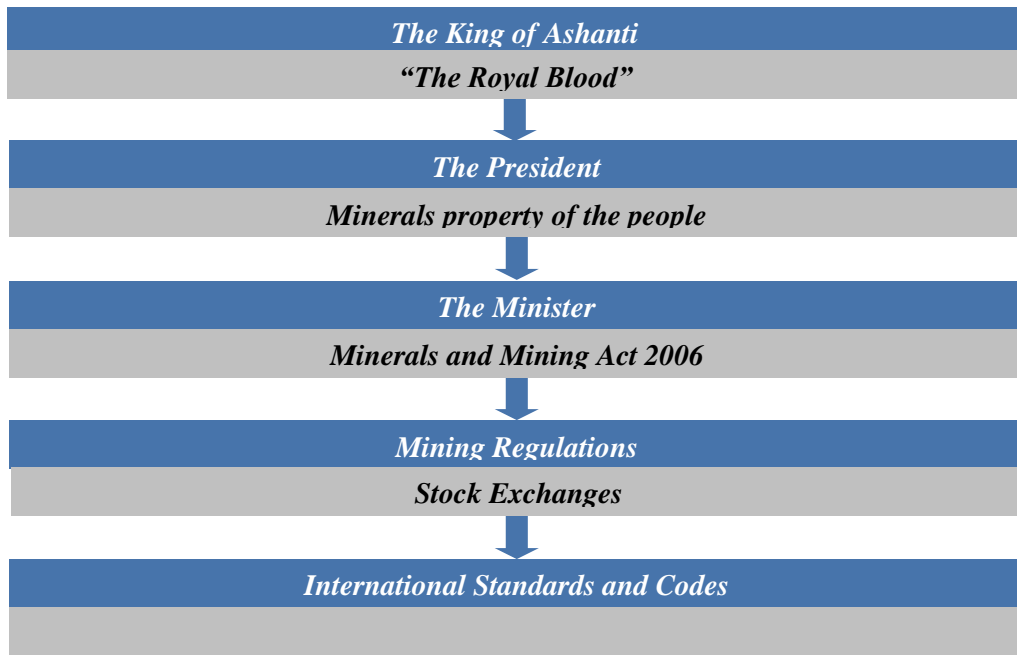

Figure 2.5 The overarching governing components

2.5 Outcome from the research and reviews

Although the mining components will be tabled in detail in paragraphs to follow, it is critical to include the governmental structure responsible for governing the mining sector: -

- Mining legislation of Ghana
- Minerals Acts
- Mining Regulations
- Survey Regulations
- Safety and health
- Minerals Commission
- Inspectorate division

Overlying Minerals and Mining Legal Structure include the departments as illustrated in Figure 2.6.



Figure 2.6 Minerals and Mining Departments

The legislative framework is laid down in the Minerals and Mining Act, 2006. A license is granted by the Minister of Mines, who acts as an agent for the State, exercised upon the advice of the Minerals Commission (MINCOM, 2010).

Relevant international bodies and their general philosophies are readily available on the *World Wide Web* as referenced in previous paragraphs. However, the literature research must table any legislative components, together with signed agreements that are in place. Both Ghana and AGA conform to the international safety standards as tabled by the ISO 9001 and ISO 18001 procedures/guidelines as defined in their websites. The International Labour Organisation's principles are also adopted by Ghana and AGA (AnglogoldAshanti, 2011). The influence of the United Nations is documented in both government and mining company media. Ghana is particularly influenced by the European Union (Europa legislation, 2011).

AGA is listed on the Toronto, London, Johannesburg and New York stock exchanges. Stock exchanges have codes and rules that influence mineral acquisition and exploitation, which has obvious adherence criteria for the Mining Company per se.

Having researched the factors that influence the Minerals and Mining Acts, the author now tables the *Underlying Codes and Guidelines*. Herein lays a compliance issue which is based on interpretation and perceptions of individuals.

All responsibility and compliance is squarely placed with the company owners. The experience, maturity, structures and compliance rules will dictate how the company tables its risks and what regulations/guidelines or codes are put in place to mitigate any risk. The responsibility and compliance is detailed and is delegated by the company owners based on qualifications and experience.

The *Underlying Codes and Guidelines* are related to the Mining Value Chain as illustrated in Figure 2.7.

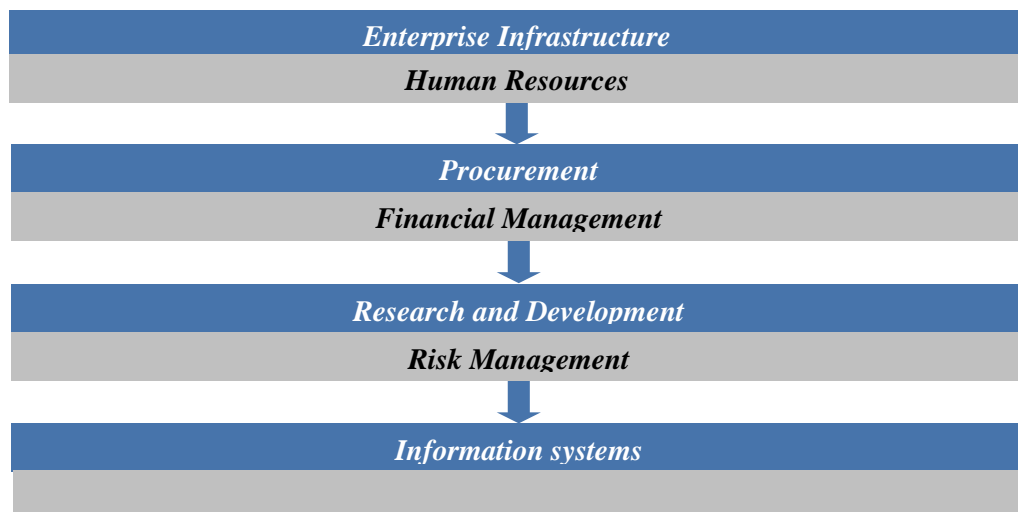

Figure 2.7 Mining Value Chain – underlying codes and guidelines

Often the initial focus is on the mining function alone. It is implied that legislation, acts, codes and guidelines are reflected in the chain. The exploration and tenure of mineral resources is a function of the first step in the chain; the second step would be the building of the mine. Extraction follows, with trucking and tramming of ore to the plants, and ultimately, recovering the content. Finally, we see the marketing and sales step, which brings in the financials and stock exchange categories.

2.6 Review of other departments and commissions influencing mining in Ghana

The boundaries of the research will be reasonably narrow in as much as a mining scope is concerned, focussing on mine surveying and associated activities. Upper and lower confines will not be bound by any level of work, but will rather look at international codes moving down to the daily tasks on a mine. The draft list of acts, regulations and codes will set the initial boundaries of the research. This list may possibly change as data is gathered.

The compilation of a Country Legislation Register (Figure 2.8) was essential in order to illustrate the levels of legislation within the hierarchy in Ghana.

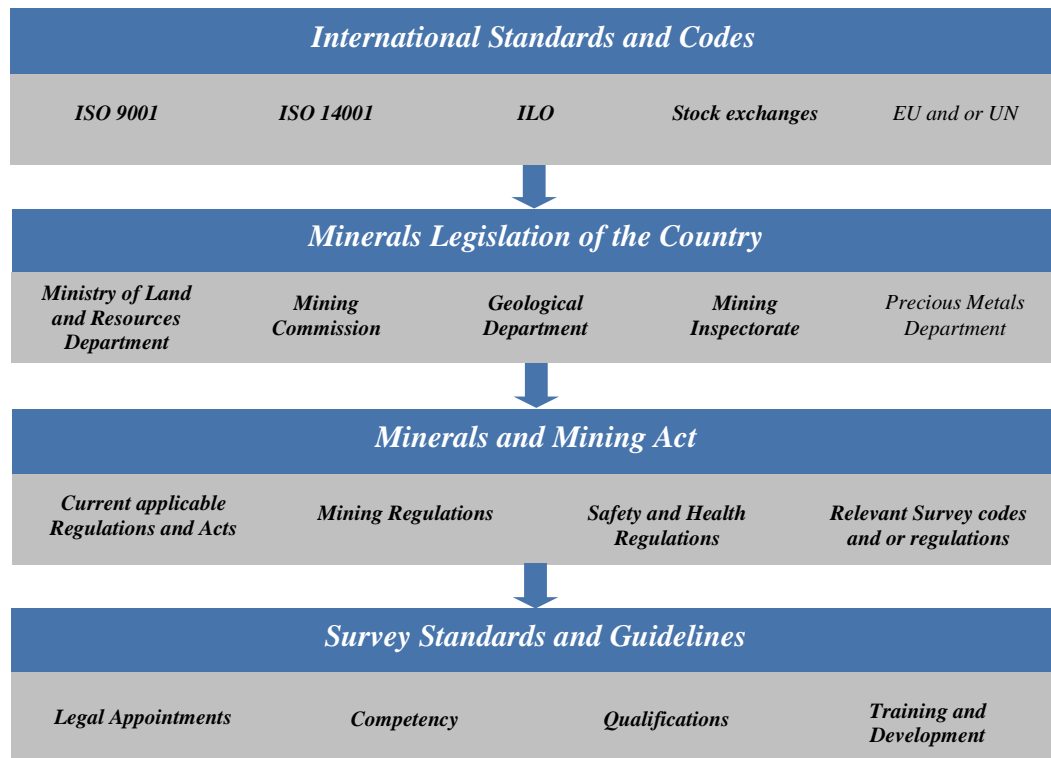

Figure 2.8 Country Legislation Register

To start the detailed research of the relative institutions, a method was derived to locate key references. Once an act or guideline is reviewed, certain key words were used to facilitate the in-depth research. The words used were, Geology, Maps, Plans, Survey, Act and Regulation. This method draws attention to pertinent issues and ensures that all relative data are researched. Key extracts from

the Minerals and Mining Act are gathered, reviewed and dissected. Key extracts from the Minerals and Mining Regulatory Framework are reviewed using the same approach, while the review of the Mining Regulations 1970 was done in detail.

Acquisition codes and regulations must be read and revised so that all areas of compliance are adhered to, which would include geology and survey.

The Survey and Mineral Resources sections are involved in the prospecting and mining rights application and adherence processes. The Environmental Act and the Social and Labour Plans often form part of the scope of application for mining rights.

Local and customary rules and regulations, with special reference to Ghana's King, Ghana's people and Ghana's environment, must form part of the research.

As well as the already mentioned European Union guidelines, International Labour Organisation and International Standards Organisations, the monetary and beneficiation codes (AGA Country Report), Stock Exchange rules, financial accounting rules, taxation and royalties also have influence. Minerals classification and reconciliation rules as in SamRec and SamVal codification, Jorc code of practice and ore accounting principles are also taken into account.

2.7 Conclusion

This chapter gave an overview of the literature and current knowledge that are applicable to the research. The main finding in this chapter has shown an overview of the legislation relative to mining and given an understanding of the hierarchy in Ghana.

Chapter 3, titled "Methodology, Review and Analysis", contains a discussion on relative institutions and the framework for mine surveying in Ghana.

3 METHODOLOGY, REVIEW AND ANALYSIS.

3.1 Overview of the contents of the literature review

Chapter 2 gave the literature and current knowledge of the topic in Ghana. It demonstrated that the area of interest required research and review to illustrate compliance. The main finding in that chapter has shown an overview of the legislation relative to mining and given an understanding of the hierarchy in Ghana.

Chapter 3 contains a more in-depth review of the literature and findings. Relative institutions with key references, key extracts from the Minerals and Mining Acts, review of the Mining Regulations 1970 and key extracts from the Mining Regulations 1970 will be tabled.

The methodology was developed after full research of applicable literature and legislation was completed. A solid understanding of all the participants and stakeholders was achieved. The flow of legislation in the Governmental Sector is shown in Figure 3.1.

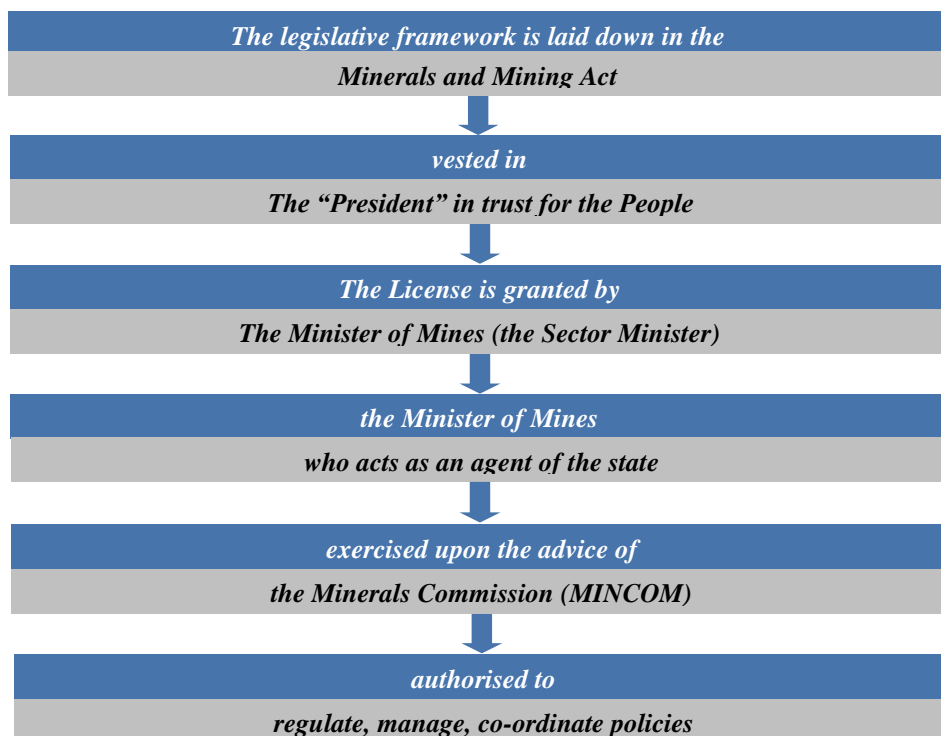

Figure 3.1 Flow of legislation in Government

At this point it is essential to produce a visual aid in order to reflect the process that the topic is to follow. Research is done at each level and illustrated in the table. This method ensures that any relevant mining or survey subject matter is not overlooked.

The hierarchy in Figure 3.2 shows the various levels that management and the relevant Mine Surveyors must be aware of, as these can contain legislation that pertains to them.

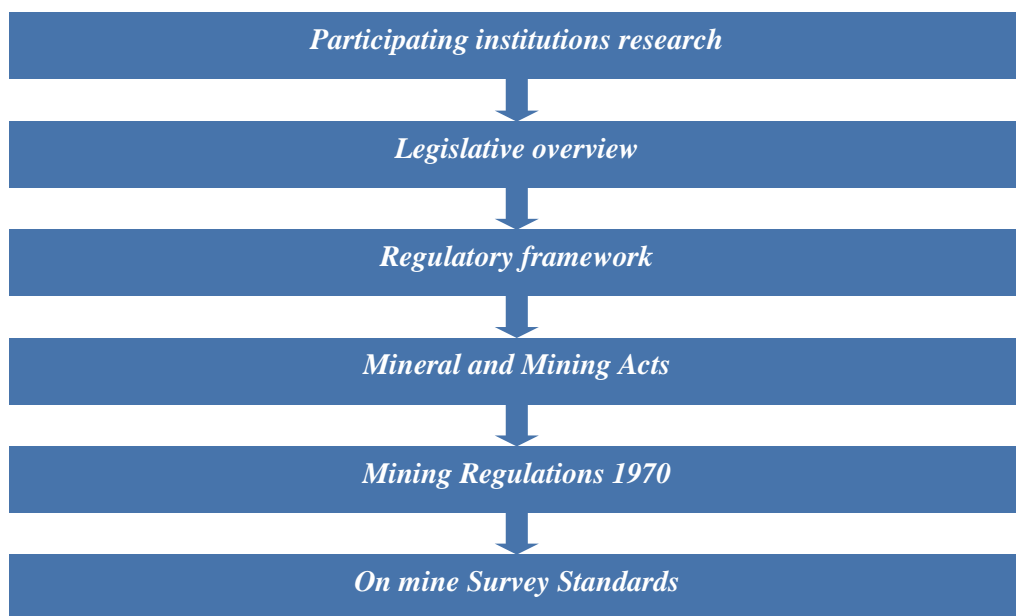

Figure 3.2 Legislation levels relative to Mining Survey

3.2 Methodology

The various components tabled above were reviewed, commented on and applied to Mine Surveying.

This report will summarise the findings, recommendations or comments on each item, as illustrated in Figure 3.3.

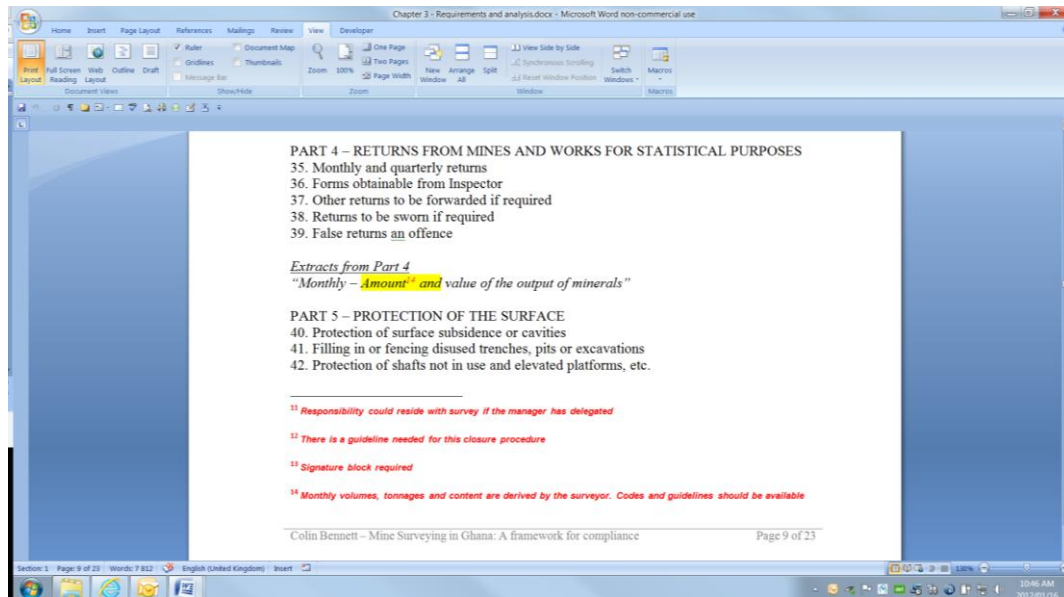

Figure 3.3 Example of the research methodology

3.3 Relative institutions with key references

The first review is at a high level within the Ghanaian mining legal structure and reflects the departments. Analyses of the relative institutions revealed that:

- The overall responsibility for the mining industry is carried by the *Ministry of Mines and Energy*.
- The first contact for prospective investors and source of essential information is the *Minerals Commission* who recommends mineral policy.
- Geological studies including map production and maintenance of geological records are managed by the *Geological Survey Department*.
- Health and safety inspections and maintenance of mining records are controlled by the *Mines Department*.
- Legal records of licences and legal examination of new applications are administered by the *Lands Commission*.
- Association of representatives of mining companies falls under the *Chamber of Mines*.

- Although environmental issues are integrated into all acts and the responsibility thereof is shared throughout the mining departments, the *Environmental Protections Agency* is the controlling body.

Table 3.1 portrays key words and phrases that need definition and would need action from the Mine Management and the Chief Surveyor¹⁸.

Table 3.1 Key words and phrases

<i>FLOWING FROM A LEGISLATIVE OVERVIEW, THE FOLLOWING MINE SURVEY ACTIVITIES EMERGE</i>						
	<i>Essential mineral policy information</i>	<i>Map production</i>	<i>Mining records</i>	<i>Legal records of licence</i>	<i>Association of representatives</i>	<i>Responsibility for environmental</i>
<i>Action required from Mine Management</i>	<i>Licensed areas</i>	<i>Accurate surface and underground plans</i>	<i>Surveyed and plotted mining areas</i> <i>Surveyed bills of quantities</i>	<i>Accurate mining license</i>	<i>Professional bodies or associations</i>	<i>Accurate plans and progress</i>

Licensed areas refer to mining or prospecting licenses issued by the authorities and includes the area of application and interest, supported by detailed plans.

The following Acts and codes regulate licenses that are issued:-

- Health and Safety falls under the Mining Act
- Minerals and Mining (Amendment) Act of 1994 (Act 475) - Minerals and Mining Law, 1986 (PNDC Law 153) amended to The New Minerals and Mining Act 703, 2006
- Rivers Ordinance (Cap 226)
- ISO14001 - Ghana's Environmental Protection Agency (EPA)
- Diamonds [Amendment] Law 1989 (PNDCL 159)
- Extractive Industries Transparency Initiative (EITI)
- Ghanaian Mining Regulations of 1970 (LI 665, LI 666)

Accurate plans are essential to any mining project, whether legalised or not. Safety and risk to people and property would necessitate accuracy. The major

¹⁸ The designation of chief surveyor is a common term used in AGA and other mining companies. It would denote the appointed and or competent person in charge of mine surveying on a mine.

focus of a Survey section would be to compile these plans so that proper risk assessments could be conducted.

Plotting the surveyed mining areas keeps the mining records up to date and is crucial for future planning at all mines. Coupled to this survey process is the quantitative function of area, volumes and tonnes. This important function can escalate to include bill of quantities and annual returns of mining production.

The areas demarcating the mining license area should not be in dispute or have overlaps with adjoining mines or license areas. Cadastral survey principles are therefore applied to the mine lease and boundary surveys so that the risk of disputes can be minimised.

It is becoming common practise for mining houses to require professional affiliation/membership for their appointed officials that carry legal responsibility. This association also has the benefit of peer reviews and a constant update of current affairs in that discipline.

The environmental responsibility not only rests with the said department on a mine, but must be supported by accurate plans from Survey through Management. These rehabilitation plans are, in some cases, now legalised and are a function of the Survey section.

The contributions of the Mine Surveyor are, for example:

- Surface and underground plans
- Calculation of areas, tonnages and content
- Construction quantities and payments
- Pit monitoring and or underground risk control.

3.4 The country specific regulatory framework for mining

The following list has been compiled from the research and review and assists in highlighting issues that may not have been deemed a function or action for Survey.

- *Compliance enforcement of occupational health **and safety regulations** for the mining sector.*
- *Inspection of areas of mineral operations to ascertain whether any nuisance is created in the area by the mining operation (**environmental monitoring**).*
- *Insurance of **operating permits** for reconnaissance, exploration and mining.*
- *Enforcement of licensing and leasing provisions of **mineral titles**.*
- *Control of mines, mills and other mineral treatment plants, ensuring that **wasteful mining** or ore treatment practices are not used in these operations.*
- *Examination and enquiries into mining related **accidents and incidents**.*
- *Compilation of **mine accidents statistics** and dissemination of information thereon.*
- *Technical inspection, control and enforcement of **technical regulations** for mining (including winning mining of building and industrial minerals).*
- ***Certification of Mine Management**, Certification for blasting, and operating of winding engines.*
- *Inspection of exploration sites and enforcement of reclamation requirements at **exploration license areas**.*
- *Participation in review of application for **exploration rights** carried out by the Minerals Commission.*

- *Assistance to the Environmental Protection Agency (EPA) in the review of environmental Impact Assessments by the participating in the work of the 'Technical Review Committee.*

Table 3.2 lists key phrases that are relevant to survey and need in-depth review and action.

Table 3.2 Survey related action to be taken

<i>FLOWING FROM THE REGULATORY FRAMEWORK, THE FOLLOWING MINE SURVEY ACTIVITIES EMERGE</i>					
<i>Safety regulations</i> • <i>subsidence monitoring</i> • <i>holings, water and gas</i>	<i>Areas for environmental monitoring</i> • <i>accurate surface and rehabilitation plans</i>	<i>Mineral titles</i> • <i>mine title areas</i>	<i>Wasteful mining</i> • <i>mine to plan</i> • <i>overbreak</i> • <i>bills of quantities</i>	<i>Accidents and incidents</i> • <i>compilation of mine accidents plans</i> • <i>falls of ground or subsidence</i>	<i>Technical regulations for mining</i> • <i>codes of practice and or guidelines</i>

Subsidence monitoring has always been critical to management and the joint contributions from the Survey and Geotechnical sections reduce the risk of accidents and incidents. Reduction and elimination of injury to people and damage to property are key areas. Technology has advanced in Survey and Geotechnical specifically for the monitoring of subsidence. The significant increase in the rate of data retrieval, analysis and processing is beneficial in keeping stakeholders informed.

Survey plays a leading role in the underground safety regulations. Accurate plans are essential and should contain the necessary geological features so that holings¹⁹, water and gas can be drilled for. "Cover drilling"²⁰ is crucial to long term planning and can influence the overall direction and strategy of underground workings.

¹⁹ Holing refers to the planned intersections of working places, typically underground

²⁰ Cover drilling refers to geological boreholes drilled ahead of advancing working places to detect water and or gas.

Unfortunately every mine creates a legacy and leaves a footprint. The methods used for rehabilitation have progressed dramatically in recent years, with some mines starting this rehabilitation as an ongoing process. These rehabilitation plans have become legal in certain countries and are an essential part of the environmental section's base data.

In order to prospect or mine for minerals the relative licenses are required. The applications for these licenses require detailed plans of the area of interest and introduce the difficult issue of surface rights' licenses and the ownership of the properties. The legislation with respect to the mining and the land must be understood and the overlap should be considered. Lack of insight could give rise to conflict for the various participating parties which can include mining company, land owner, government and environment. It is essential that plans are kept accurate, and up to date.

Wasteful mining is a deterrent to the Company and deprives many of the profits to be gained in responsible mining. Production statistics and returns to government can assure some level of responsible mining. The "bill of quantities²¹" is crucial at every operation. The base input data for these reports and returns are derived from the survey volumes, which are typically measured on a monthly basis. A secondary output from the base data is related to monies paid to contractors and certain employees.

Accident and incident plans are required on most mines and are used as evidence should there be an enquiry into an event. Accuracy of the measurement of the incident or accident is important but, of equal importance is the accuracy of the plans. This could become a crucial issue should evidence need to be submitted in court. Technical inspections from the regulatory mining body can include Survey. Adherence to specific survey regulations would be reviewed and the accuracy of plans and survey work determined. This can be supported by codes of practice and guidelines which, if adhered to correctly, can be binding. These codes are often established in order to ensure compliance to regulations.

²¹ Bill of quantities refers to the regular measurement of production and reports of the recovery of the content on a mine.

In Table 3.3 the mine survey related words and paragraphs should be analysed and reviewed for compliance, where necessary.

Table 3.3 Survey related action to be taken - continued

<i>FLOWING FROM THE REGULATORY FRAMEWORK, THE FOLLOWING MINE SURVEY ACTIVITIES EMERGE</i>			
<p><i>Certification of Mine Management</i></p> <ul style="list-style-type: none"> • <i>certification of surveyors</i> • <i>appointments of surveyors</i> • <i>responsibilities of surveyors</i> 	<p><i>Exploration license areas and rights</i></p> <ul style="list-style-type: none"> • <i>accurate surface and exploration plans</i> 	<p><i>Technical and health and safety supervision of small scale diamond mining</i></p> <ul style="list-style-type: none"> • <i>mine title areas</i> • <i>mine plans</i> • <i>mine to plan</i> • <i>bills of quantities</i> 	<p><i>Environmental impact assessments</i></p> <ul style="list-style-type: none"> • <i>assistance with rehabilitation plans</i>

The study of the legislation relating to appointments is often overlooked. The required certification is also not taken into account. It is noted that where these appointments are not made, the management, and often the owner, will be liable for none compliance. An example of this would be where the Survey section is administered by technical operators who are not competent according to regulation, and the responsibility therefore is held by the manager of the mine. Whether the manager is aware of this or not, he or she will be held liable for accuracy and safety in this area of the mine.

Exploration licenses and rights need accurate plans at all times, specifically when dealing with "green fields"²² operations.

Any environmental impact assessment requires Survey input and again, accurate plans.

In the Minerals and Mining Act (Mining Portal 2010) important Mine Survey related phrases are found and must be reviewed.

²² Green fields, refers to mining activities that are at the beginning stages of search and evaluate.

"(d) the establishment and operation of a mining cadastre²³." Most mining projects will review a plan/map showing the extent and ownership of the land. Feasibility studies will require information on infrastructure for a possible mining project. During the operational phase of mining, the general surface plan on a mine would indicate all the infrastructure and ownership of land as well as the mineral rights boundaries.

The integration of Mine Survey into a Geographical Information System (GIS) has been found to be a natural progression from CADD systems. The survey data now found in 3D spatial environments forms the foundation of a system such as GIS.



**Figure 3.4 Topographic/Cadastral
for Cape Town**

²³ This is a register of property showing the extent, value, and ownership of land for taxation.



Figure 3.5 Cadastre available to the public through Government

"(k) the returns to be rendered in relation to accounts, books and plans required to be kept by holders" For the relevant Mine Surveyors, the two responsibilities emanating here are the book of accounts relating to area, volume and mineral content and the inspection or submission of legal plans.

"(m) the nature and adequacy of a map or plan required for the purpose of this Act" A clear requirement for plans relative to the area of interest is required.

"(n) the restriction of minerals operations in or near a river, dam, lake, forest or stream" The environmental impact assessment would determine these boundaries and they would be prominent on the mine plan.

"(r) the protection of pits, shafts and other dangerous places" Physical barriers are always defined in the regulations but the restricted areas must be demarcated on all mine plans.

"(s) the reporting of accidents" Mine Surveyors will draw up accurate plans of the accident and this forms part of the report and enquiry.

"(a) ensuring the safety of the public and the safety and welfare of persons employed in mines and the carrying on of mineral operations in a safe, proper and effective manner" This encompassing sentence requires responsibility from appointed persons and refers to areas of possible incident or accident.

3.5 Review of the Mining Regulations 1970

In the previous paragraphs the focus and responsibilities revolve around the higher levels of government and mining houses. This section will reflect mining specific regulations which can lead to on mine appointments and responsibilities and must be reviewed in detail.

There is a specific chapter for mine surveying in this regulation but almost all the other chapters can, and do require survey input and ownership.

The extract below shows the format of the chapters. Not all the detail will be tabled in this research and only key extracts will be shown. However, in Part 4 all the points are reflected as this is a dedicated Survey related chapter.

PART 1 – GENERAL DUTIES OF MINE OWNERS

Owner to make financial provision

Appointment of manager

The manager of such a mine or works shall be appointed by the owner thereof, who, if an individual and suitably qualified, may appoint himself.

Owner to furnish name of mine and of manager

3.6 Key extracts from the Mining Regulations 1970

*He (The Manager) is the holder of a recognized degree or diploma in metalliferous mining, or an equivalent qualification and in addition has complied with the requirements of the Examinations Regulations; employing not more than 30 persons underground, a manager, underground metalliferous mining **experience exclusive of surveying and sampling,***

- This implies that surveying and sampling may be different legal appointments.

*The manager shall provide for the **safety** and proper discipline of the men employed **above and below ground** and shall appoint such persons as may be necessary to carry out the provisions of these Regulations,*

- Appointments may include Surveyors but do not list them as such.

PART 3- PLANS

- This portion of the regulation relates to Survey in every section-and will be dealt with in detail.

"23. Part 3 of these Regulations shall not apply to quarries and digging areas."

- This is possibly an oversight, as having a plan of workings is always necessary. Although not regulated, it would be best practice to have the mine aerial surveyed on a regular basis.

"24. The following plans shall be kept at every mine:-"

*"(1) A **general surface plan**, or a true copy thereof, on tracing cloth of the mining land or land showing the boundaries of such mining land or lands when this can be shown on a plan of convenient size; the outcrops and dip of the reef or reefs or other mineral or alluvial deposits known or being worked, all open-cast or surface workings, shafts, boreholes, reservoirs, tailing sites, railways, permanent pipe lines, aerial cable ways, electric power lines, and tramways erected or constructed for the use of the mine, and all buildings, watercourses, and other surface objects which it is needful to protect against undermining within the area of the surface of the land required for mining purposes.*

This plan shall be brought up to date biannually during the months of June and December in each year and the information given shall be correct."

- A general surface plan is necessary for all mines. This legislation describes infrastructure but fails to mention important survey related criteria. It is essential to state the survey system, scale, transformation information and orientation. A survey code or guideline should list these omissions in detail.

*"(2) (a) **An underground plan**, or true copy thereof on tracing cloth, showing clearly the boundaries of the mining land or lands when this can be shown on a plan of convenient size, also all shafts, drives, winzes, raises, crosscuts, stopes, safety pillars, stations, underground explosives magazines shall be clearly shown and all veins, spurs, or leaders that are being exploited, faults and dykes, and datum levels, and important changes in the dip of the reef or mineral deposit shall be indicated."*

- The underground plan again lists required infrastructure and covers the mining operation fully. There is no mention of survey criteria and the review of the local survey guidelines will need to show the necessary components of a plan.

*"Where different reefs or mineral deposits lie one above the other the workings on each reef or mineral deposit shall be shown on a **separate plan** by special request of the Inspector."*

- Having a separate plan for each ore body has benefits and simplifies the review and planning of the mining operation but, in the interests of safety, a composite view must be available. Where CADD is used, switching on and off of relative levels is simple but critical.

"This plan shall at all times be correct to the last measuring date and in any case shall be brought up to date every three months.

*(b) An underground plan, or true copy thereof on tracing cloth showing clearly the system of **ventilation** throughout the mine. The direction of main air currents and positions of doors, stopping, crossings, and main ventilating appliances. Intake or downcast currents to be shown on the plan in blue wash and return or upcast currents in pink wash. The plan shall be kept up to date, and shall be on the last preceding paragraph."*

- A ventilation official should assist in providing all the necessary information for the Survey section to update this plan. This information often forms part of the requirements for rescue plans, specifically for underground operations.

*"(3) A general underground plan or true copy thereof similar to the one mentioned in paragraph (2) of this regulation, but drawn to **the same scale** as the general surface plan mentioned in paragraph (1) of this regulation."*

- If CADD is available this duplication could be avoided, as all data will be in real space and scale could be plotted as required.

"This plan shall at all time be correct to the last measure date and in any case shall be brought up to date every six months.

*(4) A plan or true copy thereof on tracing cloth, showing the transverse **section or sections of the workings** and drawn through the shaft or shafts of the property, indicating clearly the dip of the strata and reef or other mineral deposit, and any dislocation of strata, intrusive rock, etc. This plan shall at all times be correct to the last measuring date and in any case shall be brought up to date bi-annually in June and December of each year."*

- Cross sections of the workings are important. The number of sections through the ore body could be increased to cover more area. Again, if CADD is available the ability to cut sections at strategic lines is quick and accurate. A three dimensional view adds value to the viewing of the operation.

*"(5) (i) Where a reef or other mineral deposit has an average dip of more than 60 degrees, a plan or true copy thereof on tracing cloth showing **vertical projection** shall be made of the mine workings."*

- Vertical projection plans will show the workings on the plane of the ore body. This plan assists in determining production advances and tonnes. Constructing projection plans is difficult on even dipping bodies, but can be extremely odious when the dip is erratic.

"(ii) Graphical records consisting of a section and site plan shall be kept of all boreholes drilled, whether on the surface or underground. Such records shall show the geological nature and widths of strata passed through, the assay values, of any reef or other mineral deposit intersected, also any dips and faults indicated, and where boreholes have been surveyed and deflections shall be shown."

- This data is essential and could be updating resources and reserves for the operation. The data must reside in the survey spatial data base. The transformation of the borehole spatial data should be noted in the operation's guidelines. The borehole measuring instruments almost always produce spatial data in a different system to that of the survey plans.

*"(6) Paragraphs (1), (3), (4) and (5) of this regulation shall not apply to mines which have not started to produce gold or other minerals. **25.** The plans provided for in paragraphs (1) and (3) of the last preceding regulation shall be laid down on a scale of either one in four hundred and eighty, one in four hundred and eighty, one in nine hundred and sixty, one in twelve hundred, and any common multiple of one in two hundred, and the underground plans provided for in paragraphs (2), (4) and (5) of the last preceding regulation on a scale of one in two hundred and twenty-five, one in twelve hundred and fifty, or one in two thousand five hundred."*

- These regulations are from 1970 and the metric system should have replaced this in recent times. There may be a request from the Survey section for exemption to carry their plans either on a metric scale or in a CADD database.

*"**26.** In all mine surveys measurements shall be made in English feet and decimals of **a foot.**"*

- As per the recommendation above, the Survey section could apply for exemption to this regulation.

"27. (1) The co-ordinates of the surface and underground surveys shall be referred, where practicable, to the same axis as the co-ordinates of the mining land survey on which the mine is situated. The co-ordinates of the mining land beacons are obtainable from the Government Chief Survey Officer."

- This regulation implies that a network of beacons should be in place, therefore standards required for the surface survey control should cover this area.

"(2) The records of all surveys made in connection with a mine shall be entered into a book set aside for that purpose, and these records shall be kept up to date. The inspector shall have the right to examine this book."

- A legal compliance for recording and calculations, as well as the associated survey notes or chits, therefore standards are required for this regulation on each mine.

"28. On all mining properties a permanent bench mark shall be established: should there be no suitable permanent stone structure one shall be built for this purpose."

- Standards for building a bench mark as well as the procedures for establishing a network is required for each operation.

"All levels taken above and below ground shall be referred to a plane above this bench mark; the height of this plane shall be fixed in each district by the Government Chief Survey Officer and all elevations shall be stated in feet and decimals of a foot below this plane. The plans on all surface mines shall, however, be referred to a datum above mean sea level."

- Guidelines for datum line references are essential and should be reflected on all plans on the operation. The establishment of the datum plane above the bench mark must be well described in the codes and guidelines of the mine. Working below datum consistently reduces errors underground while cognisance must always be taken of the relationship between underground and surface infrastructure. This is important when a surface operation sinks shafts and starts to mine from underground.

*"29. (1) Copies of plans mentioned in paragraphs (1) and (3) of regulation 24 shall be **deposited with the Chief Inspector of Mines** and shall be brought up to date to the measuring date in December send to the manager such copies at any time subsequent to 1st day of February and they shall not be retained by the manager for a longer period than one month."*

- This regulation is a standard stipulation in many countries but must be noted that the manager is responsible.

*"(2) Managers of Mines shall deposit with the Chief Inspector of Mines at his special request a true copy of any plan or section relating to the mine.
30. No copies of the plans referred to in this part or any information concerning them shall such plans be opened to the inspection of any such person without the permission of the **mine manager.**"*

- Again, the responsibility could reside with Survey if the manager has delegated or appointed a competent Surveyor to be the custodian of the plans.

*"31. (1) before any mine is abandoned or **closed down the plans** required by regulation 24 shall be brought up to date and copies thereof shall be deposited with the Chief Inspector of Mines."*

- This regulation implies that the Mine Surveyor is possibly one of the last people to leave the mine at mine closure.

"(2) In the case of any part of a mine being abandoned, the underground plan shall first be completed to date and a copy thereof deposited with the Chief Inspector of Mines. All underground workings shall first be surveyed before being permitted to become inaccessible."

- A guideline is generally in place for this closure procedure and will be reviewed in the following paragraphs.

*"32. (1) The manager of a mine who fails to keep correct plans as prescribed in these Regulations or neglects to deposit with the Chief Inspector of Mines within the prescribed periods true copies of such plans or the extensions in accordance with these Regulations shall be liable to a penalty, and the Chief Inspector of Mines shall have the power to cause such plan or plans of the mine to be made or extended at the expense
(2) All plans or copies of plans deposited with the chief Inspector of Mines under these Regulations, and also when they are brought up to date, shall be **signed and dated by the surveyor and the manager.**"*

- A signature block required for these signatures on each plan and copies thereof. The manager has added responsibilities in this regulation.

"33. The manager of a mine who withholds any portion of a mine plan, or conceals any part of the workings or knowingly and wilfully allows these mines plans to be or remain incorrect, shall be guilty of an offence against these Regulations."

- The manager must assume responsibility

"34. The Chief Inspector of Mines shall have the power to make rules from time to time with regard to mine plans for the purpose of securing uniformity in colour, and in the use of conventional signs."

- If no schedule is tabled by the regulations, there should be a schedule for signs and colours as part of the on mine guidelines.

PART 4 Monthly – Amount and value of the output of minerals

- Monthly volumes, tonnages and content are derived by the surveyor.

- Codes and guidelines should be available showing the survey process in order to derive the volumes and subsequently, the tonnes. The deriving of the content within in these tonnes, will need a guideline as well as the tabling of the reports. Ore accounting processes are integrated with the survey process to table monthly and annual results for the mine.

PART 5 – PROTECTION OF THE SURFACE

"40. Protection of surface subsidence or cavities

41. Filling in or fencing disused trenches, pits or excavations

42. Protection of shafts not in use and elevated platforms,

43. Inflammable refuse not to accumulate about headgear or buildings

44. Water containing injurious matter"

- This regulation is not all encompassing and needs supporting codes and guidelines at mine level in order to reduce risk of injury to people or damage to property.
- For surface mines, a dedicated slope stability monitoring system should be in place, supported by detailed data capture at regular intervals, as well as competent Surveyors and Geotechnical Engineers to analyse the data.
- In the underground situation, depending on the depth of the workings, the accurate representation of workings relative to possible water and or gas is critical. The continuous pumping of water from underground workings can influence surface infrastructure and create risks for the mine. Subsidence and cavity monitoring by Mine Surveyors can

mitigate and reduce risk if supporting codes and guidelines are in place and adhered to.

"prohibit the owner mining in any portion of such mine save under such restrictions and subject to such conditions as the Chief Inspector of Mines may impose."

- This regulation may refer to abandoned pillars and workings which must be accurately shown on the mine plans. The Surveyor will inform the manager if there are workings that may encroach on these areas. This may include pre-planned safety pillars and boundary pillars between mines.

PART 6 – SURFACE WORKINGS

"45. Precautions to be taken in digging trenches, pits or other excavations.

46. Danger from falls

47. Safe means of access to be provided and maintained Life line

49. Overhanging forbidden

50. Only driver to ride on dumpers, etc. where no passenger seat.

51. Terraces or benches

52. Loose material and stones to be cleared"

53. Surface working to be inspected by competent person appointed"

- This regulation needs a substantial amount of support guidelines to reduce risk on a surface working.

3.7 Recommendations

- Supporting guidelines on mine will mitigate the risk that may result from an incident or accident.
- Codes of practice and guidelines written under the framework of the country's mining legislation will support the Company's health and safety strategy.
- Generic codes of practice from best in practice could be considered. Substantial work has been completed in this area and is ready for review.

- A survey document containing standards is in place at Obuasi Mine and covers some of the “on mine” activities, but is specifically focused on underground.
- Any underground mine should have a both surface and underground guidelines/codes of practice. Each task should be in the form of a guideline, tabling best in practice. Several of these tasks are available for review for AGA.
- The surface mine will have the same general surveying guidelines but will include significant guidelines for monitoring components.
- The owner and manager of the mine are held responsible for adhering to the regulations and acts. A framework should list the structure of competent persons appointed to assist where such appointments have been made.
- Competencies, qualifications and training and development are important and will reduce risk in the long term.
- The safety and health of people, equipment and property are important and regularly form part of the risk log.
- Accurate monitoring and surveying, both on surface and underground, help manage the risks.
- The responsible personnel on mine should review the research and confirm the potential risks mentioned. Adopting generic AGA codes and guidelines would mitigate many of these risks.
- Expand these guidelines and codes into various routines and areas of work.
 - Office
 - Underground
 - Surface
 - Measuring

- Adopt a system of codification for each type of work. Use best practice philosophy with “what does good look like” principles.
- There are very few surface related survey guidelines. This will emerge in the "gap analysis" which forms part of the planned framework.
- Due to the age of the regulations and acts, there is very little reference to computers or 3D CADD systems and functions. However, the general evolution of technology may have advanced the Surveyors even though the legal requirements have not evolved as yet.
- There is no mention of appointments with specific reference to competent Mine Surveyors. This may be an additional area to be addresses in order to reduce risk.
- There has been no mention of reporting structure thus far, but internal structures will be in place and will be reviewed in detail as this project progresses.
- In the chapters that follow the risks and gaps will be tabled and recommendations offered to cover the issues found.
- There has been very little mention of qualifications and experience at the different levels of management in the review. Internal appointments and qualifications may be revealed in the codes and guidelines that reside on each mine.

3.8 Conclusion

The research and review summarised in this document call for follow-up plans. Therefore, the formation of a framework for Ghana was planned. The extracts and references highlighted in the acts and regulations need to relate to a documented code, guidelines and standards. In this case a generic AGA guideline/code of practice will suffice.

A large accumulation of data, of different origin, such as the review reveals, must move towards a central database concept. The GIS functionality is perfect for the mining environment so as to have all data linked to spatial environment which creates meaningful information for management decisions.

This chapter has reviewed the legislation in detail as well as tabling some requirements for the framework going forward. The learning's from the review of legislation now assists in the design and construction of the framework.

The next chapter will review non-legislative codes and guidelines as well as reviewing processes such as mineral resource value chains and the effect those chains have on the Survey section.

4 DESIGN AND STRUCTURE OF THE FRAMEWORK

In the previous chapter the legislation was reviewed in some detail as well as tabling some requirements for the framework going forward. The learnings from the review of legislation assist in the design and construction of the framework. This chapter will review non-legislative codes and guidelines as well as processes such as mineral resource value chains and the effect those chains have on the Survey section.

4.1 The Mining Value Chain

The value chain of any process assists all participating departments and sections in visualising their own position in the company, as well as the sections around them. Often this chain shows the probable clients and customers.

4.1.1 Primary Activities

These primary activities within the mining framework retain the “thread” which is necessary in order to follow the process flow and understand the Survey participation early in the Mining Value chain.

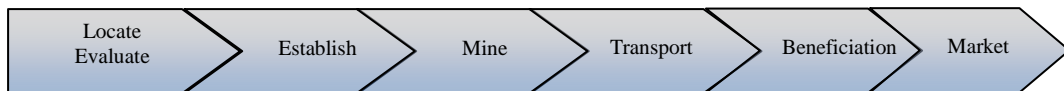

Figure 4.1 Primary Activities

4.1.2 Supporting Activities

The supporting activities underlying the mining process Figure 4.2 are often overlooked in the bigger scheme of mining. However, many of these activities can, and do have associated legally binding acts and codes



Figure 4.2 Supporting Activities

The Mineral Resource Management value chain is embedded in the Mining Value Chain. As a result the Survey discipline features prominently with regards to spatial data and bills of quantities. Survey plays a significant role as the “referee” and supplier of the bills of quantities. Most important is the underlying role as the “measurer of risk” in several areas on the mine. A brief description of the role of Mine Survey in the value chain is tabled in the next paragraph.

4.2 Mine Surveying integration

Mine Survey forms an integral part of, and plays an important role in, the construction of a mine. As such, the following Mine Survey functions should be noted:

- A survey network and system should be established in order to assist with both the construction and the mining phases.
- Ascertain what plans will be required and take the steps necessary to prepare the plans through all the stages of the mine.
- Establish baselines and bench marks as these are essential for control and monitoring.
- Establish a suitable network of survey stations.
- A suitable surface monitoring system is required and should be researched and established.

- Dams and dumps should be surveyed throughout the mining operation and these tasks should be properly planned and carried out.
- In an underground situation a suitable check survey network, with gyro bases, should be established on each level. Where possible, a co-ordinate and bearing closure from level to level would enhance the check survey of the mine. Most underground mines are established through a shaft system. The surface survey network is taken down vertical shafts via plumb wires and tapes to correlate the underground survey control. In the case of incline shafts a standard extension will be used to link surface and underground survey control.
- Survey functions on a sinking shaft are typically contained in a separate section of the Mine Survey guidelines.
- One of the major functions for Mine Survey is the calculation of positions, areas, volumes and mineral content. Guidelines should be available with the necessary company codes as support referencing.
- The responsibilities and appointment of Surveyors must be documented and accepted by all stake holders.
- All risks, safety and health issues relative to people and property are a priority to the Survey section.

4.3 Key extracts from the standard instructions document for mine surveying

The gap and disconnect to the Regulations, Minerals Act and any current framework would require additional reviews each time the acts and regulations are changed. With the necessary research and understanding having been dealt with, a high level responsibility matrix will emphasize the possible risk areas for the management of the mine within the mining sector of Ghana.

A portion of the standard instruction is tabled below in order to serve as an extract example since the full document will not be tabled. Important issues and omissions will be dealt with separately. (Appendix A)

"Purpose: To ensure that all in the Survey Department are aware and aligned with generally acceptable survey standards, practices and procedures".

Substantial focus on daily routine and general procedures is seen in the opening paragraph.

"Daily tasks will be allocated by the Section Surveyors²⁴ and entered on the "Work Sheet not later than 16:00. The Section Surveyor will discuss each job with the Surveyor²⁵ concerned, showing the surveyor the plans and relevant detail required. Details of the survey base to be used must be taken from the co-ordinate ledger, which will indicate pegs that have been re-surveyed, Surveyors will ensure that they have extracted adequate and accurate information from the office before proceeding to do the to do the required survey. The allocation of labour is the responsibility of the Survey Foreman²⁶ who will endeavour to allocate the number of assistants indicated on the work sheet by the Section Surveyor. The survey foreman will ensure that all labour, with necessary equipment, leave the survey yard for the shaft no later than 07:00 to comply with shaft schedules. Surveyors will complete the underground "PASS", where applicable, and Ensure that it is presented to the Shift Overseers²⁷ and Mine Overseer²⁸ concerned before going underground. On completion of the survey request, i.e. lines established, notes and chains sent, the surveyor will complete the relevant columns in the Survey Jobs Request Book and sign the job off."

In the "survey procedure" there are references to limits of error²⁹ which is good practice on any mine.

²⁴ Section surveyor generally refers to a competent and certificated surveyor responsible for a portion of a mine and reports to the chief surveyor of that mine.

²⁵ Surveyor refers to technical operating persons reporting to the Section Surveyor.

²⁶ Survey Foreman refers to person who leads and manages the survey assistants.

²⁷ Shift Overseers refers to mining personnel in charge of a designated portion of the mine. Usually, several miners report to this official.

²⁸ A Mine Overseer is in charge of several sections in the mine which includes several mine overseers.

²⁹ Limits of error will list the maximum variance and error allowed in the horizontal and vertical plane with respect to angular readings. All linear measurements would have check s accompanying them and these also have limits. Current technology allows the reductions to be done at the workplace.

Also, the reference to check surveys is a necessary standard but only one extension at a time is mentioned. This forms part of a daily survey rather than a separate check survey done by Senior Surveyors. Herein lies a possible suggestion for check survey procedures.

The cross reference³⁰ standards are tabled however, the instructions could be more specific. Mention is made of a field book reference but this statement would benefit from the inclusion of calculation books and processing output.

The rather short paragraph on traversing calls for more detailed guidelines. The modern codification guidelines include sketches and pictures which assist in clarifying the process.

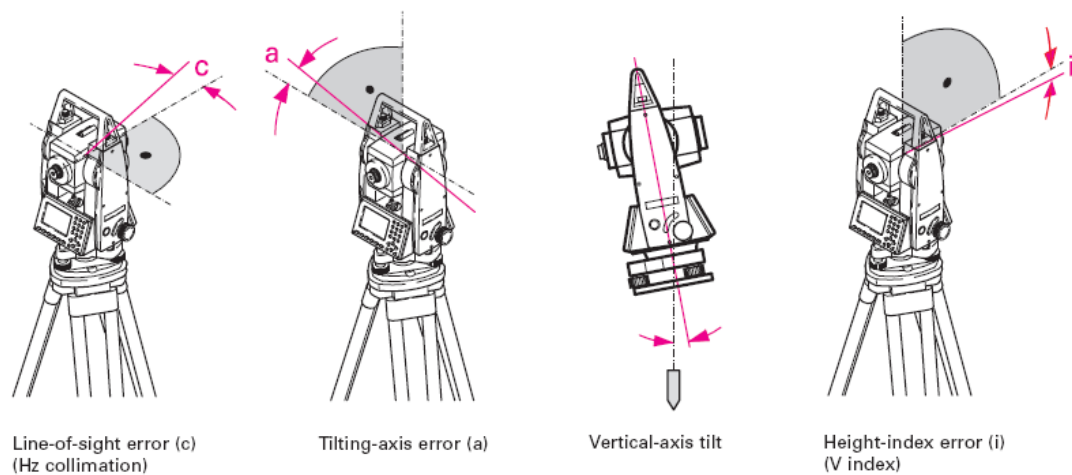

Figure 4.3 Example of guideline sketches

It would allow for stricter controls if comments such as "acceptable limits of error" are replaced with tables of the limits in the various categories of survey.

The installation of side grades can be done in conjunction with an extension traverse. As there are several variations of the practice, a separate guideline could incorporate these processes. The difficult calculations and onsite reductions can

³⁰ Cross referencing is a process to track base input data through to calculation and finally to the completed output on a mine plan.

be tabled and with the more modern theodolites, explanations of how side grades are installed using the required plane and line of sight.

The office procedure is well defined in the "instructions" with essential checking and responsibilities tabled. The classes of survey standards are tabled below but these different levels of accuracy must be detailed in the instructions. It would be important to note which level of experience and qualification would be required in each case.

"All surveys will be divided into the following classes:
- Primary Surveys: Check survey, shaft survey, engineering survey
- Secondary Survey: Main development surveys and any survey that will or can be check surveyed at a later date.
- Tertiary Survey: Surveys of box holes, raise bore, etc."

The inclusion of borehole surveys in tertiary classification may need reviewing and a reclassification to at least secondary status due to cost and importance.

In the care and maintenance section, there is reference to, and appendix for, the short term responsibilities for each Surveyor as well as the supervisors. It would be beneficial for the Survey section to table and date the survey instrument services and calibrations that are done off mine.

Table 4.1 Service and calibration register

Method	Description	Responsibility
Service roster	On the instrument asset register, services and cleaning dates must be noted and adhered to.	Mine Surveyor
Weekly inspections	Weekly inspections of all instruments must take place. Underground inspections on transportation can be performed	Surveyor
Monthly calibration	Vertical and horizontal angles must be checked and adjusted on mechanical machines. General inspection of casings and telescopes can be performed	Mine Surveyor

Stope measuring is referred to in several paragraphs and emphasises the importance of bills of quantities. It would be useful to illustrate the stope measuring sequence with more rigorous description. There is scope to produce a guideline for underground measuring procedure for development and stoping, with a separate office procedure for bills of quantities.

The term "connection holing and intershaft holings" has a single paragraph of instruction and explanation. This area of risk should attract a full guideline for the various situations that can, and have occurred on the mine. A "correlated survey" for each working end is referred to but this should be more detailed. There should be mention of closure check surveys to establish bearing and co-ordinate variances, as well as the procedure for any necessary corrections.

The representation of development ends on plan should be more detailed in the instruction and can be illustrated to enhance the required content. Once again, a separate guideline or instruction can list the various methods of direction survey and offsetting, as well as remote work with lasers and total stations.

"No person shall use or cause or permit to be used any hand drill, moil or similar tool on development faces or in stope workings liable to give off dust injurious to health unless water is applied or a wet swab is used around the drill at the collar of the hole so as to allay the dust. The foregoing does not apply to sampling or cutting of hitches"

It is understandable that the dust generated while drilling holes to install survey pegs is concerning, but the risk of ignition through sparks is also a cause for consideration. The relevant regulation relating to operating in a workplace only with permission and only after the workplace has been tested for gases, must be taken into consideration. It would be in the interest of safety and health to have "flame proof" certification for all equipment that is capable of creating a spark. This certification should be approved and registered by the relative department. Equipment capable of creating a spark would include batteries and hand held drills. Survey instrument manufacturers should have these approvals before a sale is made to a mine.

The general office procedure is stated in text but could be illustrated to allow more clarity for the Surveyors. A brief statement on "Peg Index entries and Coordinate Ledger" refers to the updating the ledger once a week. This could quite possibly be part of the daily routine due to the importance of cross referencing tabled in earlier paragraphs. The instructions are slightly disjointed and could be collated into areas of work, as well as guidelines per task.

Table 4.2 is an example of listing of office, underground and surface procedures.

Table 4.2 Survey procedure

1. Aerial laser scanning	Surface
2. Align Drilling Machines	Underground
3. Bench marks and permanent beacons	Surface
4. Bore – post drilling measurement	Surface and underground
5. CADD – plan design	Office
6. Calculate and manufacture of grade chains	Office
7. Classifications of surveys	Office
8. Closure and check surveys	Underground
9. Communication and computerization	Office
10. Development measuring	Underground
11. Development survey	Underground
12. Fine residue monitoring	Surface
13. Gyro theodolite	Underground
14. Handling and care of instruments	Surface and underground
15. Notes and cross referencing	Office
16. Offsetting development	Underground
17. Pit monitoring procedure	Surface
18. Safety and health	Underground
19. Shaft survey	Underground
20. Stope survey	Underground
21. Surface borehole alignment	Surface
22. Surface levelling and monitoring	Surface

*"The following Standard Instructions will apply to the Capital and Surface Section.
The Capital and Surface Section will receive survey requests in the usual manner as per 2.1."*

This section refers to primary and secondary surveys such as shaft sinking, development and engineering surveys. These instructions should be no different to the standard, other than to emphasise the accuracy via the limits of error stated in the initial guideline. The reference to shafts opens a new list of survey techniques and methodology and should be codified in each case.

The example shown below is a detailed "instruction/guideline" illustrating the methodology and format of a single task. This forms an important portion of the design and construction of the framework.

*The purpose of this function is to extend survey control in a shaft to ensure accurate representation of existing working places in 3 D spatial formats and for use in future planning. This function has two distinctly different operations, namely sinking and equipping.
There is also a secondary function of establishing volumes and bill of quantities for shaft lining.*

Table 4.3 Example of: - Part 1: Sinking - Planning the Work

<i>Planning the Work (Part 1- Sinking)</i>		
<i>Method</i>	<i>Description</i>	<i>Responsibility</i>
<i>Sinking plan inspection</i>	<i>Chief Surveyor and Section Surveyor will determine work to be done through detailed inspection of each plan with reference to places being advanced. Detailed sections will be available for the complete operation. The importance of the transformation parameters from design engineering plans to mine plans is critical. Height and horizontal datum must be highlighted and methodology tabled for transformation of data from one survey system to the other.</i>	<i>Chief Surveyor</i>
<i>Data extraction for task</i>	<i>In the case of steady brackets, inter plumb wire distances are essential, together with the elevation of each steady bracket. In the case of tape bracket extension, the planned elevation of the new brackets is essential. Where a bottom ring is to be checked, the plumb wire distances and required bottom ring elevation is necessary.</i>	<i>Surveyor</i>
<i>Equipment check and transport</i>	<i>Steady brackets must be on the stage for extension. The necessary bolts and spanners must also be available. Steel tapes and clino rules are part of the equipment. Wet strength books or sheets will be needed for recording of readings and results. Tape brackets and associated bolts and custom made tools are necessary. A suitable level and steel tapes are necessary. Wet strength books or sheets will be needed for recording of readings and results. The top ring elevations will be measured while pop marks on the ring will used for alignment.</i>	<i>Surveyor and assistants</i>
<i>Permissions for entry are obtained</i>	<i>Sinking times must be noted and adhered to. The work will be on a callout basis and the Survey team will travel with the sinking crew.</i>	<i>Shift Supervisor, Surveyor</i>

The guideline examples tabled are extracts from a generic set of guidelines. (Bennett 2010).

Table 4.4 Part 1: Sinking - Carry out the work

Carry out the work (Part 1- Sinking)	
Activity	Description
Preparation	<p><i>Plumb-wire³¹ positions must be chosen to suit accuracy, practicality of sinking and equipping conditions, having regard to the infrastructure.</i></p> <p><i>A minimum of four plumb-wires are to be established and should ideally be spaced equidistantly and as far apart as practicable.</i></p> <p><i>Inter-wire distances are to be kept within 0,05% of the required positions when installed and at all subsequent extensions thereafter.</i></p> <p><i>Wires must be firmly suspended and properly clamped at intervals not exceeding one hundred and fifty (150) metres. Clamping attachments should be adequately protected from accidental damage. Tension on the wires will be determined by the weight of the plumb bobs and therefore constant.</i></p> <p><i>At the bottom of the shaft the large plumb bob should be steadied and suspended in drums of water.</i></p> <p><i>Check that the wires are all clear of the stage and pipes in the shaft from old brackets passed the new area of installation and down to the drums.</i></p> <p><i>In the case of tape brackets, all old tapes to be free and straight up to new area of tape brackets. Correct tension on the tapes must be calculated and applied as per recommendation. This could equate to a hammer or similar tool of the correct weight, being attached to the tape for tension.</i></p> <p><i>In the case of a bottom ring measurement, all plumb lines and tapes must hang freely through the duration of work.</i></p>
Modus operandi and results	<p><i>All steady brackets are bolted in position. The adjustable portion is then measured. Each wire is measured for swing in 2 different directions at right angles to each other. A centre point for each will be determined from the swings. The wire will be clamped in the measured position in each case. Inter wire measurements will be taken and checked against the required distances ex sinking plan. Where variances are greater than 3mm, a "re swing" will be necessary. This may be repeated several times until the brackets are correct.</i></p> <p><i>The brackets can be elevated for reference.</i></p> <p><i>Each tape bracket is bolted and adjusted for height as required. A suitable position is chosen for the level which is bolted to the side wall. The old tapes are all read and noted. The new tapes are suspended from their new brackets and also read. The new brackets are adjusted to eliminate any variance between tapes. In both case the adjustment screws and bolts could be welded to reduce any movement.</i></p> <p><i>The bottom ring is firstly checked for elevation, at each tape bracket. Necessary adjustments are made by the sinking crew. The pop marks at each plumb wire are checked and secured by the crew. This can include snatch blocks, chains and timber inserts. Once all points at the set offset to the wires, over break is measured from the ring sets. The pop marks on the rings are punched in a ring set and checked on surface by the Surveyor. All the readings and measurements are documented on wet strength sheets and all necessary checks taken.</i></p> <p><i>All results for steady and tape bracket extensions will be checked and signed off by either the Section Surveyor or Chief Surveyor.</i></p>

³¹ Plumb wire specifications can vary slightly, depending on the number to be used as survey control. Also to be considered is the total length of shaft as well as winch specifications. The weight of the plumb bob will also be relative to length and strength of plumb wires.

Table 4.5 Part 2 Equipping - Planning the Work

Planning the Work (Part 2 – equipping)		
Method	Description	Responsibility
Equipping plan inspection	<i>Chief Surveyor and Section Surveyor will determine work to be done through detailed inspection of each plan with reference to places being advanced. Detailed sections will be available for the complete operation. The importance of the transformation parameters from design engineering plans to mine plans is critical. Height and horizontal datum must be highlighted and methodology tabled for transformation of data from one survey system to the other.</i>	Chief Surveyor
Data extraction for task	<i>In the case of steady brackets, inter plumb wire distances are essential, together with the elevation of each steady bracket. In the case of tape bracket extension, the planned elevation of the new brackets is essential. The positions of the offset line strings are needed.</i>	Surveyor
Equipment check and transport	<i>Steady brackets and tape bracket extensions are performed as is described above in the sinking. In the case of a new steel set installation and check, steel tapes, spanners and level are needed.</i>	Surveyor and assistants
Permissions for entry are obtained	<i>Equipping times must be noted and adhered to. The work will be on a callout basis and the Survey team will travel with the equipping crew.</i>	Shift Supervisor, Surveyor

Table 4.6 Part 2: Equipping - Carry out the work

Carry out the work (Part 2 – equipping)	
Activity	Description
Preparation	<i>Below the stage the large plumb bob should be steadied, on the lowest deck of the stage. Check that the wires are all clear of the stage and steel sets above. In the case of tape brackets, all tapes to be free and straight.</i>
Modus operandi and results	<i>The main steel set is received and positioned but not fixed. The offset line strings are inserted and checked. The offsets to the pop marks are checked and the necessary adjustments made to the steel set. The auxiliary sets are positioned and checked in the same manner. The pop marks on the sets are punched in a steel set and checked on surface by the Surveyor. All the readings and measurements are documented on wet strength sheets and all necessary checks taken. As many as three sets could be installed in a shift and all the readings must be taken and recorded. Any variances must be reported at the time and not on the following shift. All results for each steel set will be tabled and signed off by the responsible Section Surveyor or Chief Surveyor.</i>

Table 4.7 Pack, transport and exit

<i>Pack, transport and exit</i>		
<i>Method</i>	<i>Description</i>	<i>Responsibility</i>
<i>Equipment check and transport</i>	<i>All equipment to be dismantled with care and packed into transport containers</i>	<i>Surveyor and assistants</i>
<i>Team check and exit</i>	<i>The team should all exit together and inform the work place official of the exit A signature is required from the official</i>	<i>Surveyor</i>
<i>Exit mine</i>	<i>The Team exits as one. Safety must be a priority at all times. Risk assessments should be made when there is doubt with respect to safety of the team.</i>	<i>Surveyor and assistants</i>

4.4 Design framework for risk log and legal adherence to the various laws influencing the Mine

The framework will have a logical sequence targeting the international influences down to the day to day tasks as in Table 4.3 to Table 4.7. It would therefore be important to populate the risk log as shown in Table 4.8. From the research work completed, key references are listed in the columns, while the proposed responsible persons are listed in the rows. These items are not all compulsory but some references are legal and therefore binding. The outcome will certainly highlight the gaps and risks. It is understood that AGA has internal accountability levels of work and should therefore cover the log substantially.

Table 4.8 Risk log

	<i>Key references</i>	The Owner	The Manager	The Plant Manager	The Environmental Manager	The Surveyor
Ministry of Lands and Natural Resources	<i>responsibility</i> for resources					
Ministry of Mines and Energy	<i>responsibility</i> for the mining industry					
Minerals Commission	recommends mineral policy					
Geological Survey Department	<i>map production</i> and maintenance of geological records					
Mines Department	health and safety inspections and maintenance of <i>mining records</i>					
Lands Commission	<i>legal records of licences</i> and legal examination of new applications					
Chamber of Mines	<i>association of representatives</i> of mining companies					
Environmental Protection Agency	overall <i>responsibility</i> for environment					

Once the risk table has been completed and investigation carried out where necessary, management will have the assurance that all aspects of legislation have been dealt with and will have a sense of comfort in this area of risk.

4.5 Construction of the framework

The national and international codes and standards is part of the framework. The International Register and Framework shown in Table 4.9 is an overview of the African version for the Company.

Table 4.9 International Register and Framework

International register Reference	Ghana
Regal and/or Presidential Rule	The King is a traditional and integral part of the country. The minerals of the country are vested in The President, in trust for the people.
Ore Reserves and Mineral Resources	Mineral Resources and Ore Reserves conform to the JORC Code, 2004 edition as well as to the standards set out in the South African Code for the Reporting of Mineral Resources and Mineral Reserves (the SAMREC 2000 Code).
ISO 14001	Environmental Management System (EMS) certified to the ISO14001 standard.
ILO	The Company is committed to upholding the Fundamental Rights Conventions of the International Labour Organisation (ILO),
Applicable Stock Exchanges	AngloGold Ashanti’s primary listing is on the JSE (Johannesburg Stock Exchange). It is also listed on exchanges in New York, London, Paris, Brussels, Australia and Ghana.
EU and UN	<ul style="list-style-type: none"> • United Nations Global Compact (UNGC) • International Council on Mining and Metals (ICMM) • Responsible Jewellery Council (RJC) • Global Reporting Initiative (GRI) • Extractive Industries Transparency Initiative (EITI) • International Cyanide Management Code for the manufacture, transport and use of cyanide in the production of gold (Cyanide Code)(ICMI)
OHSAS 18001	OHSAS 18001: The Occupational Health and Safety Assessment Series, presents requirements for an occupational health and safety management system.
World Health Organisation (WHO)	AngloGold Ashanti’s malaria programmes and protocols are based on World Health Organisation (WHO) standards
King Report/King 2	It is the policy of the AngloGold Ashanti Group to comply with the King Report on Corporate Governance of South Africa 2002 where the Company deems it appropriate.
Sarbanes-Oxley (SOx)	Sarbanes-Oxley Act of 2002 – introduced into law in the United States to set new corporate governance standards for corporate boards and accountability standards and penalties for corporate management.

The mining companies need to comply with current country legislation but a framework is necessary to ensure compliance in all departments. Over and above the framework requirements mentioned, the adherence to these country laws and codes would be mandatory. Where gaps are evident it would be critical for those gaps to be bridged with the Company best practice guidelines.

The Country Register (Table 4.10) lists the current relevant acts and codes to which the mines must adhere.

Table 4.10 Country Register

<i>Country register References</i>	Ghana	Guinea	Mali	Namibia	Tanzania
Mine Health and Safety	Health and Safety falls under the Mining Act	Title holder to draw up regulations	Reference to Safety and Health in the Code	Mine Health and Safety Regulations (10th draft)	Mining (Safe Working and Occupational Health), 1999
Minerals Act and or Mining Act	Minerals and Mining (Amendment) Act of 1994 (Act 475) - Minerals and Mining Law, 1986 (PNDC Law 153) amended to The New Minerals and Mining Act 703, 2006	Guinea\Country specific Register\Guinea Code 1995	Mining Code - Order No 99-032/P-RM of Aug 19, 1999 Mining Act	Minerals (Prospecting and Mining) Act, 1992 (Act No 33 of 1992)	Mining Act Cap. 123, Section 5 (50 of 1991), Mining Act 1998
National Water Act	Rivers Ordinance (Cap 226)	Reference to underground water issues in the Code	National Water Regulator referenced in the Code	Territorial Sea and Exclusive Economic Zone of Namibia Act, 1990 (Act 3 of 1990)	National Water Act (36 of 1998)
Land Survey Act	Under the Lands Commission there is a Land Survey Department	None found	Director of Mapping and Survey and references in the Code	Townships and Division of Land Ordinance, 1963	Land Survey Act (8 of 1997)
Environmental Management Programme	ISO14001 - Ghana's Environmental Protection Agency (EPA)	Environmental Management and Protection Regulation of 1999	Environmental code	Environmental Management Act of 2007 (EMA)	Environment Management Act, 2004
Precious metals or stones (export of minerals)	Diamonds [Amendment] Law 1989 (PNDC 159)	Reference to precious metals and stones in the Code	Reference to precious metals and stones in the Code	Diamond Act, 199 (Act No 13 of 1999)	Mining (Mineral Trading) Regulations, 1999
Investment act	Extractive Industries Transparency Initiative (EITI)	Reference to investment in the Code	Convention for the Settlement of Investment disputes	Minerals Development Fund of Namibia Act 1996 (Act 19 of 1996)	Tanzania Investment Act, 1997
Mining Regulations and rules	Ghanaian Mining Regulations of 1970 (LI 665, LI 666)	Mining Act 1998 - Convention de Base (for Mines and Quarries)	Reference to Mining Regulations in the Code	Mines, Works and Minerals Ordinance 20 of 1968	Mining (Dispute Resolutions) Rules, 1999

4.6 Chief Surveyors key performance indicators

Company Management and the Chief Surveyor will use the review and the framework tabled in Table 4.11 to measure the compliance with respect to mine surveying in each country. Even in the absence of codes or legislation to warrant these KPIs, it would be deemed to be “best practice” to put these measurements in place.

Table 4.11 Key Performance Indicators

<i>Key performance indicators for Chief Surveyors</i>	Section	Ghana
General Requirements	Relevant legal/competent appointment <i>(reference country law or on mine regulations)</i>	
	Area of responsibility (mining right) <i>(mining area and mining right plans)</i>	
	Survey System <i>(local and global with constants and transformation criteria)</i>	
	Survey network <i>(underground and or surface configuration)</i>	
	Survey records <i>(all data captured, calculated and drafted to be retained)</i>	
Safety Precautions	Workings being advanced <i>(all surface and underground working face positions)</i>	
	Ground movement monitoring system <i>(surface subsidence control and data analysis)</i>	
	Surface structures or objects <i>(mining activities relative to :-)</i>	
	Boundary and safety pillars <i>(mining activities relative to :-)</i>	
	Check survey <i>(closures in azimuths, coordinates and elevation)</i>	
Survey Practices	Survey stations <i>(construction, accuracies and uses)</i>	
	Standards of accuracy <i>(limits of error in all levels and types of survey for underground and surface)</i>	
	Accurate representation on plan <i>(scale and projection to be considered)</i>	
Mine Plans	Details required <i>(name of mine, title block and legend etc)</i>	
	Plans to be kept up to date <i>(responsible persons signature and date of update)</i>	
	Inventory of plans <i>(all plans including superseded plans)</i>	
	Types of plans <i>(level plans, sections, rehabilitation, contour and other legislated plans required)</i>	
	Departmental copies <i>(legal submissions required)</i>	
Bill of quantities	Quality ore accounting with audit trails <i>(flow of ore and waste system)</i>	
	Accurate measurement of extraction of the ore body <i>(surveyed volumes and tonnes)</i>	
	Integrated and dynamic auditing cycles for ore and waste accounting <i>(weekly, monthly and annual reconciliation of all ore and waste)</i>	
	Integration and application of technology <i>(one version of the base data entry)</i>	
	Reduction in risk in resources and reserves <i>(second party checks on all data at all levels)</i>	

4.7 Conclusion and recommendation

After listing the areas of concern or possible non-compliance, the necessary guidelines and actions must be implemented to fill the gaps. As the research has shown in the previous chapters, there are areas where best practice can be adhered to. Where the KPI's are not relevant or not understood, a peer review should be undertaken to define the issues of concern.

This chapter has shown that the legislation was reviewed in some detail as well as tabling several portions for the framework going forward. This chapter has reviewed non-legislative codes and guidelines and assisted with the framework, down to the survey level of operation.

The next chapter will discuss implementation and testing.

5 IMPLEMENTATION AND TESTING OF THE SURVEY FRAMEWORK TABLES

The previous chapter showed the framework tables that will be used as guidelines in establishing risk index and producing a gap analysis guiding future decisions of the mine. In this chapter the implementation and testing of the framework tables will be discussed. Feedback from the mines will also be considered for the purpose of refining the framework. The guideline document has suggestions on defining the risks as well as a general responsibility table for Mine Surveyors.

5.1 Establish a Gap Analysis for the Survey discipline

The differences between the current guidelines and practices that are applied on the mines and the key extracts from all acts and codes reviewed in this research should be compared.

The heading of the example tabled in Chapter 4 is shown below as a reminder.

<i>Key performance indicators for Chief Surveyors</i>	Section	Ghana
---	---------	-------

- The Chief Surveyor and senior members of the Survey Department should read the relevant acts, codes, standards and guidelines that are applicable to the exercise.
- Members should take note of the areas of risk, safety and best practice, listing the findings with action plans or next steps.
- The confirmation of timelines, such as short term or long term action plans should be tabled. Special emphasis on quick wins followed by a responsibility matrix can be considered.

The example of the management structure below does not show the levels of work within the Survey structure. This matrix can be populated for all the identified risk actions tabled for the Survey section.

<i>Key references</i>	The Owner	The Manager	The Plant Manager	The Environmental Manager	The Surveyor
-----------------------	------------------	--------------------	--------------------------	----------------------------------	---------------------

- Consultation with peers and management is essential where new or different methods or actions are required. This may refer to additional technology or training and development. Expert opinions should be sourced where necessary.
- Formalisation of the Surveyors' personal curricula vitae in order gauge levels of expertise and training needs, will inform Survey and Mine Management and assist in the development and training necessary to fill the gaps.
- The material considered necessary to move forward on the planned next steps must be available to support the process, for example: audit sheets, together with the framework tables will assist with a self checking process.
- The Company will have a full set of best in practice standards and guidelines for reference in each country.

5.2 Process flow

Figure 5.1 gives a visual guide of the process that unfolded during the review and report. The most notable feature is the complex integration and interfacing with the various sections and departments.

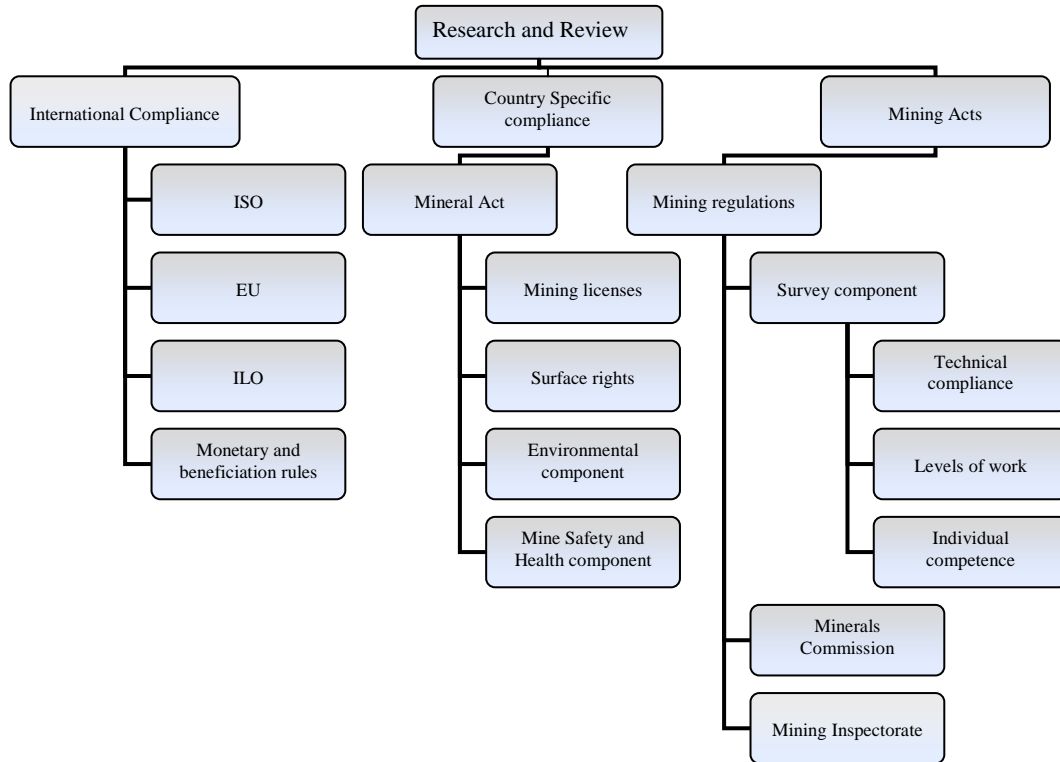

Figure 5.1 The Process flow

The framework requires a set of actions and next steps in order to fill the gaps and reduce the identified risk. There is a substantial amount of reading and research to be done on each mine. This will need to be scheduled and apportioned to the senior level surveyors. An example of sharing the workload is shown in Figure 5.2.

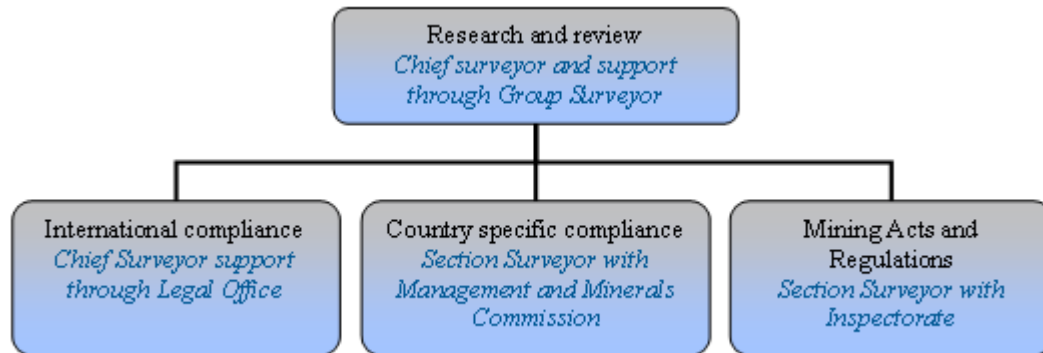

Figure 5.2 The work load route

5.3 Correspondence review and feedback

Extracts from correspondence between the author, management and individuals on the mines show the significant amount of communication that took place during the research. It is evident from the conversations that the flow of information began with on mine versions of survey instructions, which were analysed in detail. The difference between what the regulations ask for and what the mine has interpreted as instruction, required careful review.

From:
Sent: Wednesday, November 03, 2010 05:27 PM
To:
Cc:
Subject: RE: Code of Practice

Hi,

We have Standard Instructions, a document we are reviewing and hope to get it ready by close of the year. Attached is a copy.

Regards

The standard instructions referred to in this correspondence were general in context and referred to preparation rather than specific survey practice guidelines. This research and review tables detailed survey functions supported by general codification.

From:
Sent: 03 November 2010 14:20
To:
Subject: Code of Practice

Hi,

Do you have a code of practice for mine surveying, if so; could you send me a copy please?

Regards

Only the “on mine” instructions are in place and not a binding code of practice.

Hi,

I have confirmation that the regulations have not been gazetted as yet.

Regards

The above correspondence refers to a draft update of the Mining Regulations. The update was reviewed but not incorporated in this research.

Hi

I have started the report document in a much better word format than the working files I had before. Ignore the presentation; we can use it if necessary if the audience is right. (Pages 1 - 4)

I have taken slides from that ppt and elaborated issues where needed. Also you will find the extracts from the different regulatory components that need discussion. That is on pages 5 – 7.

Page 8 notes work in progress but I attach the detailed research I am doing on the 1970 regulations. (still feet and inches, needs discussion)

Page 9 will review the Survey standard instructions for Obuasi only, also limited to underground.

Regards

The initial report needed to be brought up to date in format and presentation. Work flow and process required definition and explanation so as to address both the managerial and lower levels in the Survey sections.

Hi

Attached please find a review of the document you sent me on codes. Finally find a Zachman's planner model survey.

Briefly, the reviewed document is policy at company level and looks good. If the work has been done in that respect, at region or mine level, then those "on mine" procedures should be reviewed.

As you know systems are critical and they should be reviewed in conjunction with the procedures.

The Zachman model is a draft to cover the questions that must be asked at the various levels.

I trust this is to your liking although I believe there is more alignment to be done.

Regards

The annual reports of the Company were reviewed for compliance and best practice. The resultant literature review was tabled in earlier chapters. The comment emphasises the Company's compliance at Group level for country and international acts and codes.

Hi

I have put this framework together, which we can re use where ever in any country.

I reverted back to learning's from Wits, as in the Mining Value chain as firm base, framework.

This framework tables the entire process and gives us a "road" to follow as we drop down.

Each block has a substantial amount of detail which can be unpacked e.g. slide 2 Minerals and Mining Act, 2006 and or international codes (ISO) etc

Slide 2 has the Ghana flow and associated departments of interest. They too have detail we will table.

I carry the value chain string in each slide for continuity and reference.

Slide 3 starts to take on the survey activities we believe emulate from the value chain and Ghana regs

Slide 4 is my proposal for drop down into survey activities for which we have plenty of regs and guidelines. (This would receive more attention after review from your people) The gaps are showings in respect to appointments and responsibilities. Managers are liable in almost all cases, but have not delegated responsibilities or ensured systems are in place. (My view based on studying the regulations and act). We do not see the emphasis on slope stability monitoring and not enough detail on underground check surveys and gyro bases)

So, please review our framework and add your suggestions and views. But this would suffice for all your African mines

If this is what we want I will start the drop down and detailed references to Ghana regs and acts to highlight the gaps to your people.

Regards

This correspondence shows the progress in the research at that time.

From:
Sent: 19 January 2011 10:48 AM
To:
Subject: RE: STANDARDS AND PROCEDURES

Hi,

Thank for your response. I have gone through the file and I appreciate it very much. My eyes have been opened to areas where hitherto I have not considered to be included in our standard procedure.

I think the idea of having a common code of practice for the Africa region is great, this I believe will help lift up standards in operations where standards are low. Also when new technologies and methods, which were operating in other areas, are adopted there would be codes and standards ready to guide procedure and usage.

In Obuasi, our standard procedure is very old; it talks more to periods when our activities were purely manual and steel tapes and optical Theodolites were used to survey. Here are few points to consider for our specific case:

- There have been considerable changes in our mining method, we use to do square-set and Cut and Fill stoping but now we are doing Open stoping and Sublevel Caving. This new code of practice should instruct surveyors in both the old and new methods.
- Most of the current survey field data is digital, buy use of Total Station and other digital survey equipments; there should be codes on how to keep and preserve field data collected.
- We don't have standards for GPS, I hope there would be standards for our usage.

Regards

This communication illustrates the positive reception of the framework for Ghana, particularly at Obuasi. The framework has been adopted and localised, which was the original intent. The requested detailed standards were sent to the mine to enhance their local set of standards.

From:
Sent: 18 January 2011 06:54
To
Subject: RE: STANDARDS AND PROCEDURES

Hi,

Yes – It is a rough outline of a format in which we want to present a new Code of Practice. I was hoping you could give me some comments or suggestions.

It sets the environment in which we as surveyors work, i.e. down from the United Nations' Codes, the International Labour Organisation's guidelines, into national law and industry codes and finally company guidelines.

The idea is that a mine surveyor gets this book - once fleshed out – and understands what is required from him/her to be legally compliant everywhere that AGA operates – i.e. this will be a guideline on how to do work in the AGA Africa territory. In Ghana specific reference will be made to Ghanaian circumstances however the practices described in the Code of Practice will apply to all countries in which we do work.

I'd appreciate your opinion – would this make sense?

Regards

The summary of the implementation of the framework is important confirmation that the project was tabled, accepted and implemented.

From:
Sent: 15 December 2010 10:29 AM
To:
Subject: STANDARDS AND PROCEDURES

Hi,

I received a file from _____ containing standards and procedures for survey and he asked me to review it. May I know exactly what is required of me for that file?

Regards

The sharing between colleagues and peers is illustrated in the mail posted above. This implies that the implementation and testing component is working.

Hi

Please review this framework and add any comments or additions.
I think it will serve the mines well as a base check. Some mines already have guidelines while others need a substantial change in theirs.

But as you said the chief surveyor should be guided rather than given the end product.

Regards

The research and review in African countries and mines within the Company served well to identify gaps at Company level and revealed their best practice areas. The peer review process will assist in levelling the survey guidelines and standards.

5.4 On Mine guideline comparisons

The guidelines used on each mine in the various countries are reviewed for best in practise. The chapters listed on the left-hand column in Table 5.1 are merely headings and will attract substantial content in each case.

Table 5.1 Current “on mine” guidelines

On mine chapters and guidelines	Ghana Iduapriem (Open Pit) Obuasi (U/G and Surface)	Guinea Sigiri Gold Mine (Open Pit)	Mali Sadiola (Open Pit) Yatela (Open Pit)	Namibia Navahchab (Open Pit)	Tanzania Geita Gold Mine (Open Pit)
On Mine codes or SOP	Ghana\Chapters and guidelines\Standard Instruction1	<i>Not available yet</i>	Survey House Keeping Procedures	<i>Not available yet</i>	Mining (Safe Working and Occupational Health), 1999
Responsibility/ Service level agreement					√
Survey history					√
Reference and compliance list					√
Terms and definitions			√		√
Safety and Health					√
Origin/point of departure /bench mark	√				√
Transformation					√
Accuracy and network classification	√				√
Communication	√		√		√
Computation	√		√		√
Beacons					√
Ground movement monitoring					√
Care and maintenance of equipment	√		√		√
Aerial surveying					√
Terrestrial scanning					√
Shaft surveying		NA	NA	NA	NA
Underground surveying	√	NA	NA	NA	NA
Surface surveying					√
Mine plans	√				√

A general observation can be made with reference to both Tanzania and Ghana in that there are currently substantial guidelines in both countries to ensure survey practise. This is however, not the required best practice level that this review has tabled.

5.5 Assurance and Audit

A methodology used in determining gaps in the survey processes, standard practices and general compliance is done through the use of audit templates. The broad areas of interest would be Survey, CADD and Ore Accounting. The discipline lead, with the technical leadership, may perform these assurance reviews on at least an annual basis. An alternative method of audit would be a peer review. The detail in the various guidelines would differ from mine to mine based on the mining method. Underground traversing using survey stations in the hangwall would differ considerably to the traverse from beacons on surface. Surface and underground survey methods would require different audit templates. However, surface plans and much of the CADD functionality would be generic. The survey instruments used and the level of technology would also dictate modifications in the template for the assurance.

SURVEY ASSURANCE

Mine

KEY PERFORMANCE AREA	CRITICAL SUCCESS FACTOR	TARGET	STRETCH TARGET	ACTUAL SCORE	COMMENTS	NEXT STEPS
DATA CAPTURING	1.1 Are all survey stations and points captured according to procedure	3	5	4.0		
	1.2 Are all the necessary checks and balances adhered to	3	5	3.0		
	1.3 Are there monthly tonnage surveys - GPS/total station/photogrammetry performed	3	5	4.0		
	1.4 Is there robust base data capture for survey instruments' data	3	5	4.0		
	1.5 Are all surveys captured within the "limits of error"	3	5	4.0		
	1.6 System security	3	5	4.0		
	Average:	3.0	5.0	3.8		
DATA MANAGING	2.1 Are all survey stations and points managed according to procedure	3	5	4.0		
	2.2 Are all the necessary checks and balances adhered to	3	5	4.0		
	2.3 Is there robust base data managed for survey instruments' data	3	5	3.0		
	2.4 Are all surveys computed within the "limits of error"	3	5	4.0		
	2.5					
	Average:	3.0	5.0	3.8		
DATA REPORTING	3.1 Is all survey information available to relevant stakeholders?	3	5	4.0		
	3.2 Is all survey work formally documented?	3	5	4.0		
	3.3 Is there a robust system and data administration in place	3	5	3.0		
	3.4					
	Average:	3.0	5.0	3.7		
LAND MANAGEMENT	4.1 Is there participation in the EMPR and or rehabilitation programs	3	5	4.0		
	4.2 Are all water courses and reticulation on plan	3	5	4.0		
	4.3 Are all cables plotted	3	5	3.0		
	4.4 Are the Mining Rights boundaries plotted and shown on plan	3	5	4.0		
	4.5 Are all features and structures/servitudes shown on plan	3	5	4.0		
	Average:	3.0	5.0	3.8		

Mine Surveyor:

Group surveyor

Date:

Figure 5.3 Assurance template

Attaining best practice is encouraged by the use of targets and stretch targets. Key performance areas are generally already defined and are accompanied by critical success factors. An additional tool would be a visual result for management information.

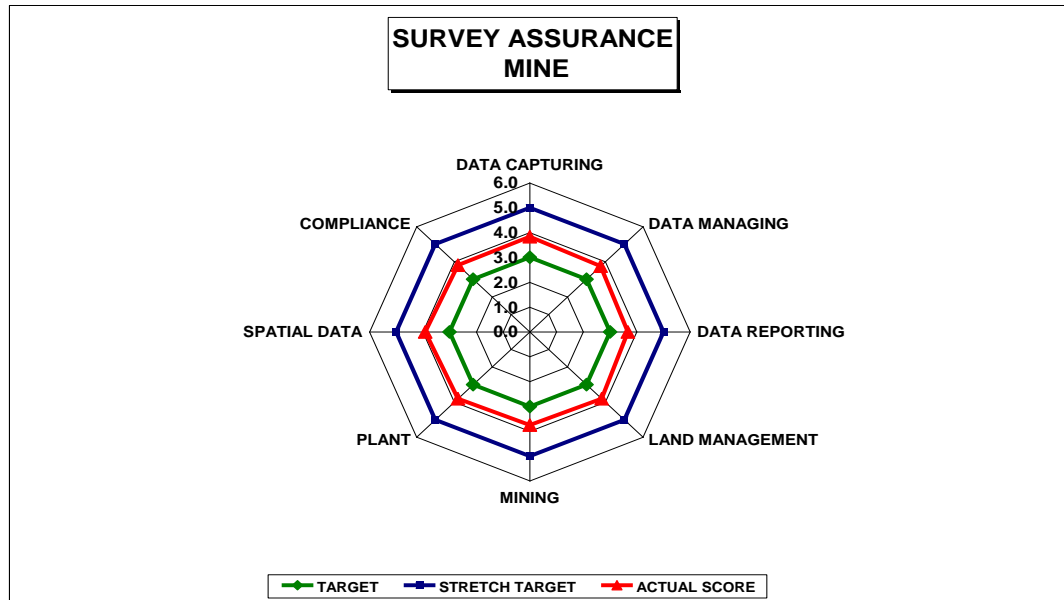

Figure 5.4 Assurance graph

These templates are easily copied for other key performance areas. Where the Group Surveyor has reviewed the Survey section there would be an accompanying summary and gap analysis with recommendations and next steps. These next steps can be signed off by the Chief Surveyor.

5.6 The levels of work in the Survey section.

The concept for the establishment of levels of work within a Survey section is a matrix by The Zachman Framework (Zachmans International 2008) which uses the house building process to establish a level of work as shown in the left-hand column of Table 5.2. Each row cascades the contextual item down to the various working levels. Once this hierarchy is established, the six project questions are asked for all the levels and actions.

Table 5.2 Survey Planner Model

	What (Things)	How (Processes)	Where (Location)	Who (People)	When (Temporal)	Why (Motivation)
Planner model (contextual)	<i>Quality assurance of the accurate measurement of extraction or the ore body</i>	Accurate Spatial data Capture External audit Internal audit	Mine	Mine	Annual	Annual report Acquisition of capital expenditure
Owner model (conceptual)	Quality design of all ore body models	Secure integrated databases	Relevant management structure	Relevant management structure	Annual	Samrec code of practice Legal compliance
Designer model (strategic)	Accurate depletion of ore models	Photogrammetry GPS General surveying methods	Survey	Chief Surveyor	Quarterly	Actual depletion and production results, strategic, short and long term plans
Builder model (tactical)	Accurate design and depletion of surfaces and excavations	Photogrammetry GPS Laser Design General Traverse	Survey	Section Surveyor	Monthly	Creation of 3D digital and spatial models
Sub-contractor model (operational)	Quality level plans and 3 D models	Digital photos Tachometry GPS Mine design	Pit, surface underground	Production, development and stoping surveyors	Monthly	Capture spatial data
Product model (execution)	Accurate level plans	Levelling, traverse tachometry	Pit, surface underground	Production Development Stockpiles Technical surveyors	As and when required.	Capture spatial data

Although this is an example of only one critical success factor or risk log item, all the remaining CSFs³² for the Survey section must be completed. The necessary tasks are established together with the level of work and by whom these are performed. Often the complement in the section does not cover the level of work, which in turn indicates gaps within in the survey structure. Similarly, the skills required are revealed and a full research of competence at each level needs to be undertaken. Training and development reviews will address the competence issues raised by this exercise.

³² Critical success factors

5.7 Individual Capability

Most mines and companies compile individual capability tables which are updated annually. The review process cannot continue without an update of the individual capability tables which are shown in the next paragraph.

5.8 Abridged CV

The abridged CV is initially completed by the employee, and is then used as reference and information in the training and development process.

Abridged CV (to be completed by the employee)			
INDIVIDUAL CAPABILITY (High level, detail only)			
Name:			
Job Title:			
Division/Department:		Company:	
Grade:	Age:	Service:	
Languages:		Educational Qualifications:	
<ul style="list-style-type: none"> • • • 		<ul style="list-style-type: none"> • • • 	
Career History (include pre-AGA experience)			
<i>From</i>	<i>To</i>	<i>Job title</i>	<i>Company</i>
Accomplishments/Achievements:			
<ul style="list-style-type: none"> • • • 			
Date completed/updated:			

Figure 5.5 Abridged CV

5.9 Individual Profile

The example of the individual profile shown in Figure 5.6 commits both employee and employer to certain agreed training and development criteria.

Group Service:			
Service in current position:			
Name:		Current pipeline role:	
Job title:			
Grade:		Operating at correct level?	Yes <input type="checkbox"/>
			No <input type="checkbox"/>
Strengths:	Accomplishments:	Performance:	
▪	▪	Potential:	
▪	▪	<i>As per 9 box</i>	
▪	▪		
Qualifications:		Development needs:	
▪		▪	
▪		▪	
▪		▪	
Possible positions: (Are these aligned to the employees aspirations?)			
Short term (1-3 years):	Medium term (3-5 years):	Long term (5-10 years):	
▪	▪	▪	
▪	▪	▪	
▪	▪	▪	
Mobility restrictions:		Date completed:	

Figure 5.6 Individual profile

5.10 Succession planning template

The need to extrapolate the planned training and development into the medium and long term window for the section rounds off the process and again highlights gaps in the succession profile of the section and company. Not all management teams share this succession planning matrix with the individuals but the Chief Surveyor definitely needs this planning tool for his own strategy.

Figure 5.7 shows an example of a succession planning template.

Position	Name	Gender	Race/Nationality
1. Ready now candidates (ready within 1 year)*			
2. Ready later candidates (ready within 2-3 years)*			
3. Candidate from outside the function*			

Figure 5.7 Succession plan template

5.11 Summary of the Proposed Company's Survey guidelines

Standards for Mine Surveying have been around in different formats for many years. Universities have published various land survey codes and mine surveying has relied on company training centres for their material. Some codes of practice have been developed based on Country Law, but a more generic working guideline is tabled. In addition, the explosion of technology has necessitated the enhancement of outdated methods.

5.12 Closing

This chapter has shown the process followed for a "gap analysis" with feedback from the mines. There are proposals on defining the risks as well as a general responsibility table for Surveyors on mine. Added to the framework tables are the levels of work example, followed by the individual competence review.

The gaps identified by the analysis must be prioritised through risk assessment and a strategy, along with implementation plan, measuring targets and target dates must be developed.

The next and final chapter will show a summary of the research and report with recommendations and conclusions.

6 SUMMARY, RECOMMENDATION AND CONCLUSION

The previous chapter showed the process for the gap analysis, feedback from the mines, early suggestions and guidelines, proposals on defining risks and a general responsibility table for Surveyors on mine. Added to the framework tables are the levels of work example and the individual competence review.

This chapter will show recommendations, conclusion and the result of the research and review, together with the tables and framework required to assure compliance by the Survey section at all levels of governance and legal guidelines.

6.1 Summary

6.1.1 Process for literature review

The recipient of this framework will refer to the literature review for guidance and process, in order to establish compliance across the full spectrum of the mining value chain.

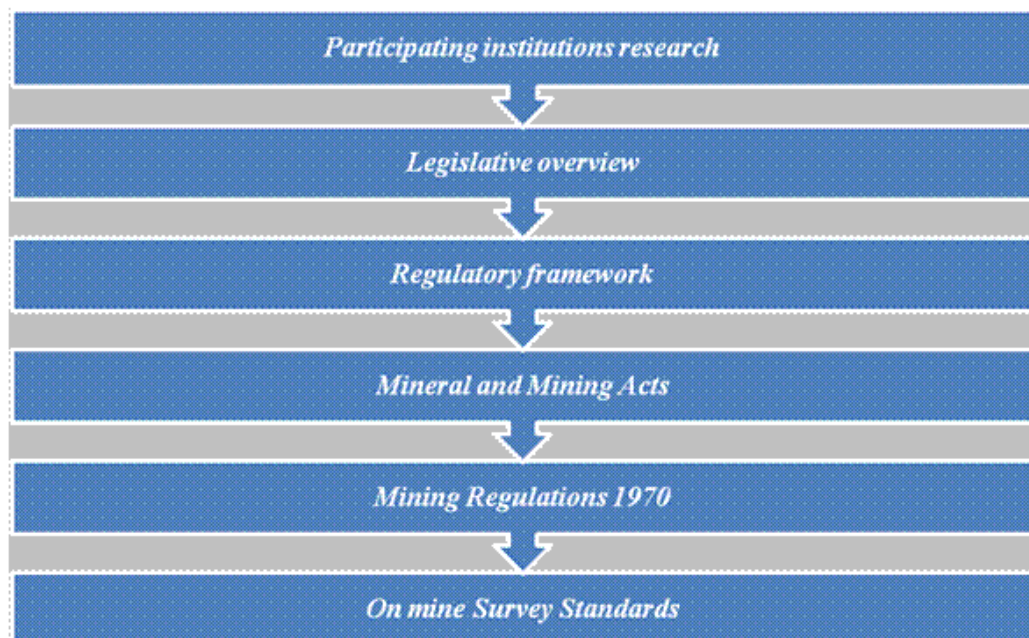

Figure 6.1 Literature flow

The extraction of relevant survey data and activities is the prime objective, while not overlooking important supporting activities and disciplines in the research.

A methodology is tabled in the framework, which leads the recipient in extracting survey related data, and with the use of key words, any related functions within the Survey discipline.

6.1.2 Mine Survey integration

The framework will assist in placing the Survey section within the mining value chain. The MRM value chain takes the Survey section into a more in-depth understanding of the process of resource reconciliation. A separate framework for resources and reconciliation will be of great value due to the integration of Survey in that part of the mining business.

This “positioning” and therefore understanding of the value add that the Survey discipline provides, simplifies the review and process analysis.

6.1.3 Risk log

The risk log table and check facility assists the Surveyors in identifying their areas of risk and in introducing action plans or next steps to mitigate these of risks.

6.1.4 The Country Register

The information regarding the relevant acts and codes to which the mine must adhere is carried in the company profile or annual reports. The company’s global compliance will be stated, as will each country’s specific compliance list. Even though a comparison between the countries may not be of any significance, in the interest of best practise this comparison would bench mark each country’s compliance.

6.1.5 Key performance indicators for Chief Surveyors

The Chief Surveyor “Gap Analysis” for the Survey discipline has been tabled and leads the discipline into a list of next steps. To recap the categories for key

performance indicators there are general requirements, safety precautions, survey practices, mine plans and bills of quantities.

Following the gap analysis, “Levels of work” are reviewed in an attempt to fill the identified gaps. However, this also leads to the next “result”, namely competence to operate at the levels tabled.

The commitment by both survey management and operating survey staff is an element of the gap filling exercise for levels of work and individual competence.

6.1.6 Mine guidelines comparisons

The mine guideline comparison not only serves as a benchmark for each mine, but could assist in lifting the competence and technical skills on the mine

This sharing of technical expertise and standards among peers can fill gaps and prevent operational errors.

The reduction in work and prevention of duplication across the company is an additional value add.

6.1.7 Summary of the proposed Company guidelines

The summary intends to cater for all the mines in the Company. The argument of the open pit mine not needing underground guidelines is true, but many surface mines do eventually go underground and having the guidelines in place would be beneficial. Similarly, although office routines and responsibilities may differ, most of the fundamental processes are valid. The surface survey process and plans will have common standards and guidelines on every mine.

6.1.8 Appendix with a proposed code of practice for the Company

The use of the word “code” in many areas could imply a legally binding document and as a result many companies tend to use the term “guidelines” or “standards”. This is an individual company choice and there must be clarity in this regard.

The proposed standards were developed from Southern African codes and compliance to these proposed standards will enhance the overall ability to adhere to global limits of error.

6.2 Recommendations

There are several key areas and processes that are highlighted in this research and report. These must be emphasised as they are part of the success of the review and research.

Firstly, the international codes and acts have been included in the report in an attempt to assure the Company and Mine that they are compliant at the top level.

Secondly, the research methodology is important. Progress would have been extremely slow if the internet search and subsequent word association search had not been used. Prompting the documents with key “survey type” words focussed the research on the relevant issues.

Assurances, audits, compliance to country and international codes, as well as knowledge of the relevant acts are essential when the framework is applied. The assurance and audits will immediately highlight areas of concern and risk. The most recent legal acts and codes must be scrutinized, interpreted and applied to the local guidelines.

The relationship between compliance, competence, levels of work and training and development is revealed as the process unfolds. The composite of the Survey section has built up over time and may have changed to suit current conditions. Where there is work being completed by individuals who are not trained or developed to a specific level, errors could occur. The levels of work and

associated competency checks will align the Survey section to the standards and limits of error required. The training and development of individuals in order to comply with the levels of work and therefore the guidelines and codes, is of equal importance.

This framework can be applied by the local Survey section. A peer group which is available for comment and support is of significant assistance to the Survey section. Such a peer group or peer review can reduce the effort and enhance the quality of any research. The framework can be applied to other mines in the same country.

After reviewing specific country codes and acts, the framework and process can be applied to other countries in the company fold.

The final concept and process can be adapted and applied across the continent.

6.3 The Survey manual

After the Company, Mine and Survey sections complete the compliance framework, it would be extremely value adding to compile the ultimate Mine Survey Manual. The manual would be a “blue print” to be used as reference for the Survey team, as well as for other mining departments who may need detailed explanation into the functions and operations within the discipline.

This manual will retain operating standards across all the Survey sections in the Company, even if they are operating in different countries. On isolated mines where Surveyors do not have the benefit of training, peer review and assurance, it is often the case that standards are dropped or incorrect practices creep in. The manual would alleviate these problems.

It must be stressed that this manual has to be kept up to date. Technology is on an ever increasing exponential curve. The new technology will need guidelines and training. The previous standards will remain in place as a backup and to cater for the mines that have not yet progressed to the new ways of surveying. It is

therefore strongly recommended that each mine should develop a comprehensive Mine Survey Manual that is aligned with the framework and corporate strategy of the Company.

6.4 Conclusion

The important results emanating from this research and report are not only a framework for Surveyors to follow in the interest of best practise, but the focus on adherence to legal issues, especially safety and health. Having the correct standards and guidelines in place, with a full understanding of any risks, will reduce risk and subsequently accidents and incidents.

Also to be mentioned is the learning curve each mine and each Surveyor will go through, adding to their appreciation and knowledge relative to the Company, the Mine and themselves.

The advancement of individuals is possibly not emphasised as much as it should be. Training and development, and operating at the correct levels would in itself reduce risk.

There is tangible evidence from communications tabled and subsequent sharing of knowledge, that value has been added in the participating Survey sections.

Any project needs a scope of works and associated timelines. The process flow has been tabled, as has the possible structure of the research team. Adopting the framework concept of three streams of work and three different project timelines can be planned.

- Firstly, the international research timeline.

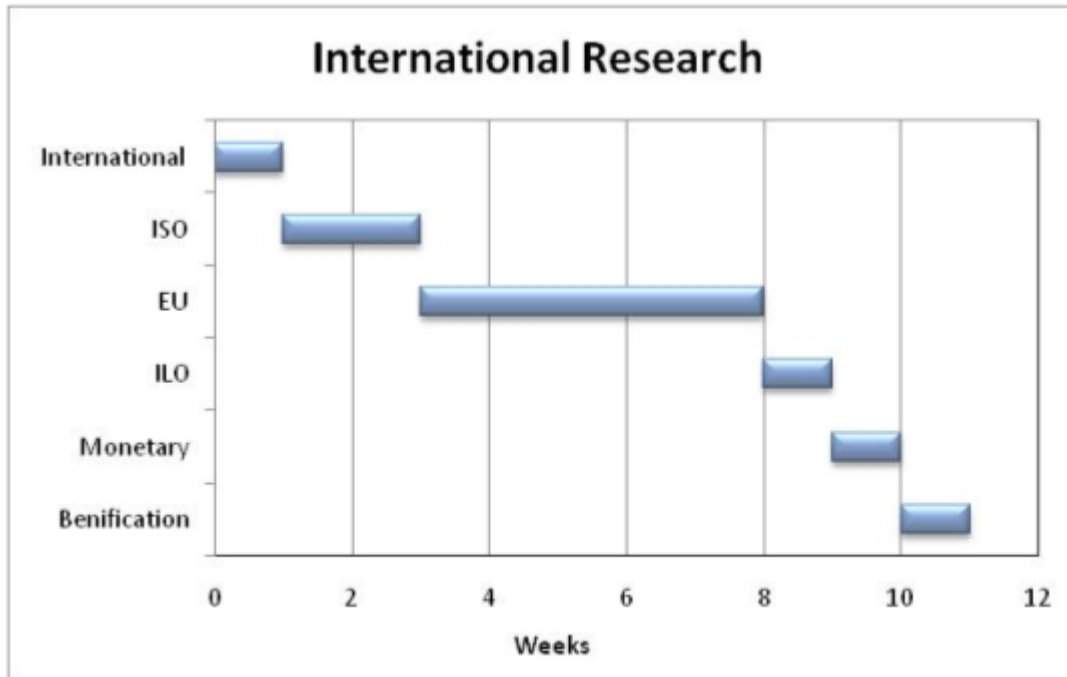

Figure 6.2 International research chart

- Secondly, the Country research timeline.

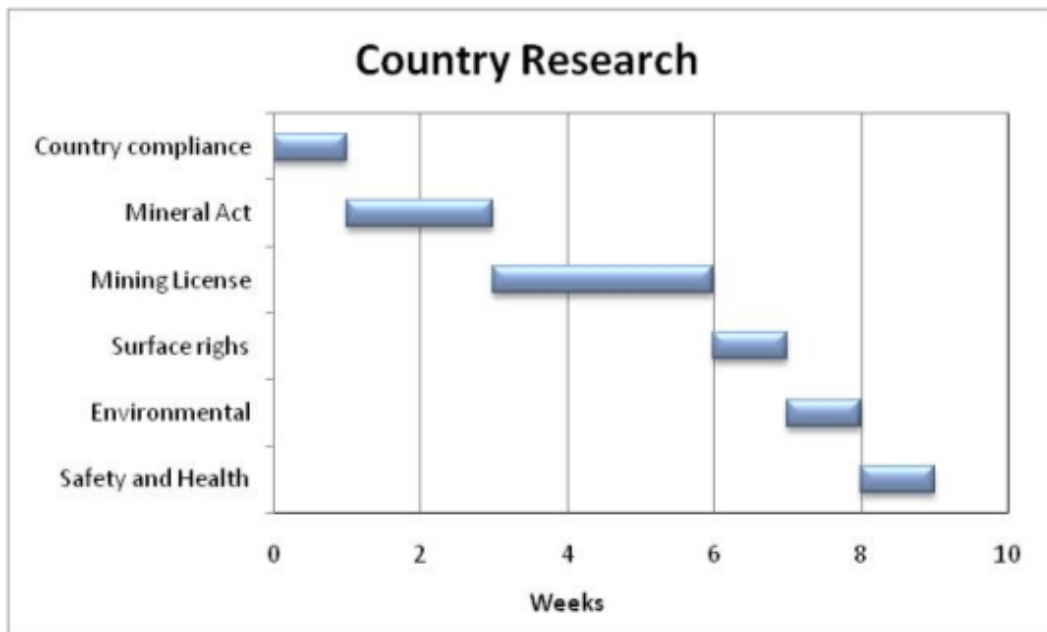

Figure 6.3 Country specific research chart

- Thirdly, the Mining Regulations research timeline

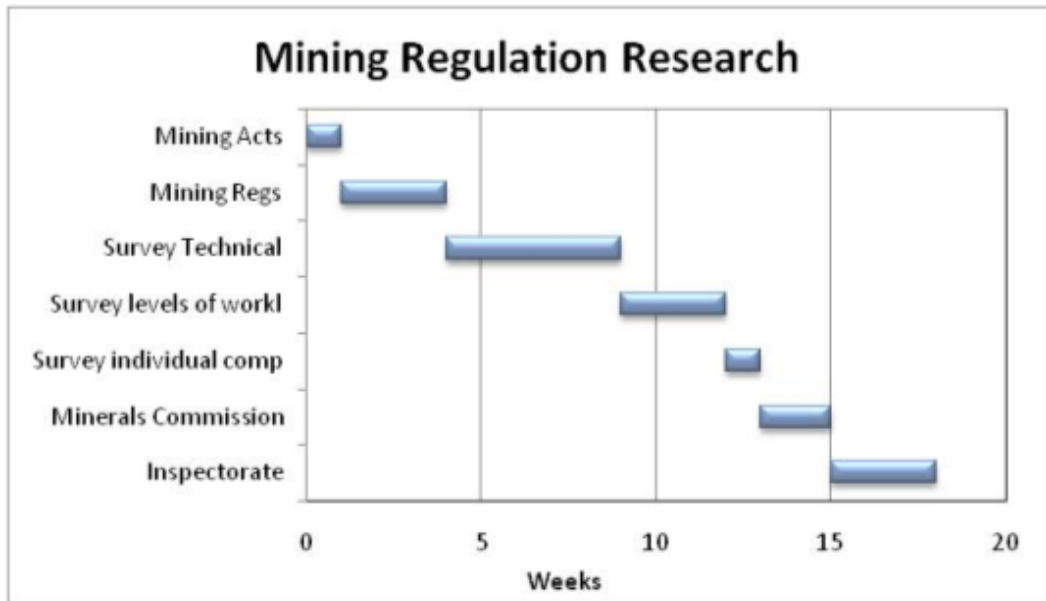

Figure 6.4 Mining Regulations research chart

The Chief Surveyor will need to manage the overall outcome, so these three timelines may have to be treated in a linear fashion. This changes the total timeframe from a maximum of 20 weeks to a more realistic total period of 40 weeks (Figure 6.5).

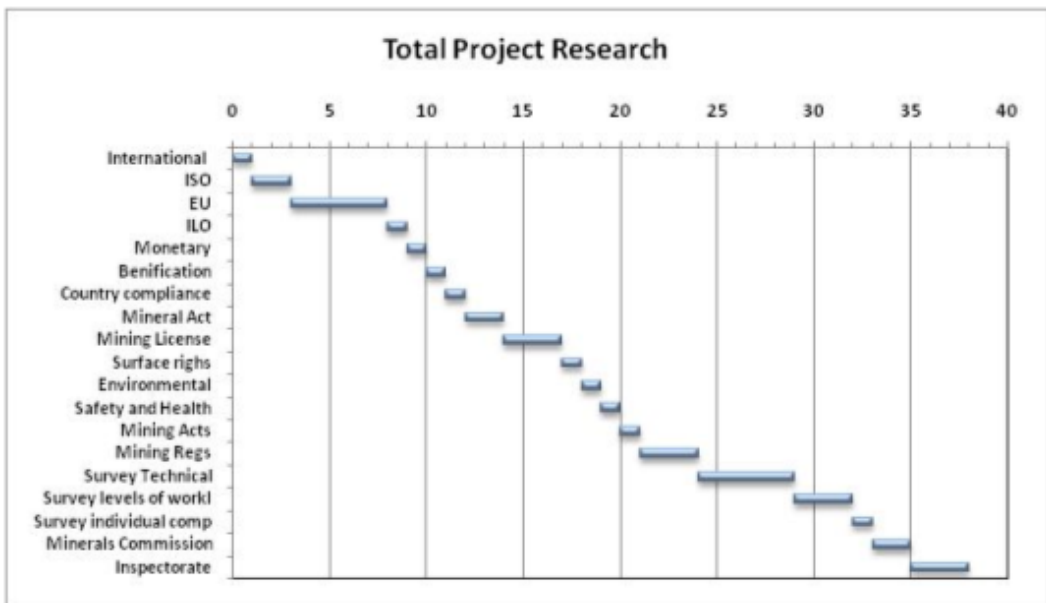

Figure 6.5 A view of the total implementation timeline

Finally, the representative “pack” of templates which populate the framework are found in Appendix B. This is a visual example of work to be done by the mine and the process to be followed.

REFERENCE

Referencing was started before the research and report process was begun. Some cited dates are monthly only, as these are referrals to progress reports on the literature review for the Company the work was being performed for. Also to note the websites in several cases have been updated and info may differ slightly.

Africa Mining Vision (AMV, 2009) The Africa Mining Vision is a pathway, formulated by African nations themselves. Internet.
<http://www.africaminingvision.org/> Cited 19 September 2011.

Africa Mining Partnership (AMV, 2009) cited within the AMV.

Mining Journal, 2010 (Dauda, 2010) Selected portions of an extract quoting the Minister of Lands and Natural Resources Hon Alhaji Collins Dauda, MP. Internet
<http://www.mining-journal.com>. Cited 11 August 2010

Obuasi Country report 2008. The annual report for the AGA mine in Ghana. Internet.
<http://www.anglogold.co.za/subwebs/InformationForInvestors/ReportToSociety06/files/Obuasi.pdf> Cited 01 November 2010.

Mine Health and Safety Act, 1996 (Act 29 of 1996). South African mining act which contains Chapter 17 relative to mine survey. Internet.
www.info.gov.za/acts/1996/a29-96.pdf. Cited 15 December 2010

Ghana (Mining Portal, 2010) The Ministry of Lands and Natural Resources (Mines Subsector) and its Agencies offer this website to provide a transparent information source and equal opportunities for all investors and the general public. Internet <http://www.ghana-mining.org/ghanaims/>. Cited 20 November 2010

European Union, 2010. The “Summaries of EU legislation” website presents the main aspects of European Union (EU) legislation in a concise, easy-to-read and unbiased way. It provides approximately 3 000 summaries of European legislation, divided into 32 subject areas corresponding to the activities of the European Union. Internet http://europa.eu/legislation_summaries/. Cited 16 February 2011

Mbendi, 2010. MBendi Information Services (Pty) Ltd is a privately owned Internet business publishing company founded in 1995 and based in Cape Town, South Africa. The company uses the Internet to support business and political decision makers. Internet. <http://www.mbendi.com/>. Cited 06 March 2011

Infomine, 2011. Infomine-africa.com is the official website for Mining Africa Yearbook, which for the past 22 years, has served as a first-line reference source, providing information about mines, mining and exploration activities in Africa. Internet. <http://www.infomine-africa.com/>. Cited 18 March 2011

Country Reports (AGA, 2010) AngloGold Ashanti, a global gold mining company Headquartered in Johannesburg, South Africa, AngloGold Ashanti has 20 operations on four continents and several exploration programmes in both the established and new gold producing regions of the world. AngloGold Ashanti employed 62,046 people, including contractors, in 2010. Internet. www.anglogoldashanti.com. Cited November 2010

Ghana Minerals and Mining Act, 2006 Act 703 (Minerals and Mining Act, 2010) The Ministry of Lands and Natural Resources (Mines Subsector) and its Agencies offer this website to provide a transparent information source and equal opportunities for all investors and the general public. Internet. <http://www.ghana-mining.org/>. Cited 02 November 2010

Mining Regulations of 1970 (*Mining Regulations, 1970*)Internet <http://www.ghana-mining.org/>*Cited 2 October 2010*

Minerals Commission (*MINCOM, 2010*) Internet <http://www.ghana-mining.org/>. cited October 2010

International Labour Organisation 1996. The ILO is the international organization responsible for drawing up and overseeing international labour standards. <http://www.ilo.org/>. Cited February 2010

European Union (Europa legislation, 2011) The “Summaries of EU legislation” website presents the main aspects of European Union (EU) legislation in a concise, easy-to-read and unbiased way. It provides approximately 3 000 summaries of European legislation, divided into 32 subject areas corresponding to the activities of the European Union. Internet http://europa.eu/legislation_summaries/. Cited February 2010

Zachmans Framework (copy right 2010). The Zachman Framework™ is a schema - the intersection between two historical classifications that have been in use for literally thousands of years. The first is the fundamentals of communication found in the primitive interrogatives: What, How, When, Who, Where, and Why. (<http://zachmaninternational.com/>) Internet reference is cited 2012 but first cited in 2001 as university notes.

APPENDIX A MINE SURVEY GUIDELINES

SURVEYING, MAPPING AND MINE PLANS

1. DEFINITIONS

- a. ***“bedded mineral deposit”*** means any reef, coal seam, lode, mineral bed or fissure, which occurs conformably within it’s country rock and is not of a massive nature;
- b. ***“chart datum”*** means the height referencing datum as determined by the hydrographer of the navy;
- c. ***“competent person”*** means:
 - i. in the case of an underground mine or an opencast mine where blasting takes place, a person in possession of the appropriate mine surveyor’s certificate of competency; or as prescribed by mining law and regulations
 - ii. in the case of an opencast mine where blasting does not take place, a person who is in possession of either –
 1. an junior certificate in mine surveying and who has at least three (3) years practical experience in mine surveying; or
 2. a person in possession of at least a qualification in mine surveying and mapping registered on a national framework and which qualification includes appropriate and relevant legal knowledge; or as prescribed by mining law and regulations
 - iii. in the case of mining at sea, a person in possession of the appropriate mine surveyor’s certificate of competency related to sea mining; or
 1. a national diploma in hydrographic surveying issued by a tertiary institution accredited; or
 2. a person in possession of at least a in hydrographic surveying qualification registered on the national qualifications framework and which qualification includes appropriate and relevant legal knowledge as prescribed by mining law and regulations

- d. “**fixed position**” means any point other than a **survey station** which is fixed within the relevant accuracy requirements for the class of survey concerned, and which is used for the purpose of locating details to be shown on **plans**;
- e. “**fluid material**” means any substance, excluding gas, that has a potential to flow, including water, slimes and mud;
- f. “**hazardous service**” means any object, structure or installation rendering a service with a potential risk to health or safety;
- g. “**plan(s)**” means any plan, section or projection required to be prepared by guidelines;
- h. “**reserve**” means any piece of land over which a servitude is registered or reserved for possible registration of a servitude in respect of roads, railways, power lines, pipe lines, conveyor lines, canals, etc.;
- i. “**restricted area**” means any area where mining is restricted due to significant risk;
- j. “**risk assessment**” means the hazard identification and risk assessment;
- k. “**safety pillar**” means every portion of a reef, mineral deposit or ground left *in situ* for the support and protection of the surface, objects thereon or underground workings;
- l. “**sea**” means the sea as defined in the sea shores act,
- m. “**survey point**” means any easily identifiable point located by localized surveying, other than a **survey station**;
- n. “**survey station**” means any point that has been surveyed within the prescribed standards of accuracy; and
- o. “**workings**” means any excavation made or being made for the purpose of searching for or winning minerals or for any purpose connected therewith.

2. GENERAL REQUIREMENTS ON LAND AND AT SEA

a. **Responsibility for Surveying, Mapping and Mine Plans**

- i. The relevant legal appointment (employer/holder/manager) should engage the part-time or full-time services of a **competent person** to be in charge of surveying, mapping and mine plans at the mine, and

- if the services of more than one *competent person* are engaged, ensure that their functions do not overlap.
- ii. No person may withhold from the relevant legal appointment, any survey records or *plans* prepared in terms of the guidelines.
 - iii. The relevant legal appointment should take reasonable measures to ensure, in all surveying and mapping done and all plans prepared by the *competent person* referred to in guidelines that-
 - b. ***Units of Measure*** - all units of measure conform to the relevant system, except angular measurements which should conform to the sexagesimal system;
 - c. ***Survey System*** - all mine surveys conform to the prescribed mining law and regulations. The projection origin may however be changed to reduce the numerical values of the co-ordinates. Survey systems established on a mine prior to prescribed mining law and regulations, may be retained provided that a tabulation of the co-ordinates of at least 3 (three) ***survey stations***, in both the existing and the national control survey system, are shown on every sheet comprising a ***plan***;
 - d. ***Datum Plane*** - elevations determined above and below ground on a mine refer to mean ***sea level***, based on the prescribed mining law and regulations. In the case of prospecting and mining at ***sea***, all elevations determined and soundings taken should refer to ***chart datum***;
 - e. ***Chart Datum*** - elevations determined at sea for all offshore mine surveying and mapping should refer to ***chart datum*** unless otherwise specified by prescribed mining law and regulations. The relationship of ***chart datum*** to the land leveling datum should be noted in the title block of all ***plans*** of prospecting and mining operations;
 - f. ***Colours and Sign Conventions*** - all ***plans*** conform to the conventional signs and colours provided by prescribed mining law and regulations;
 - g. ***Back up of Electronic Information*** - if survey records required in terms of these guidelines are kept electronically, they are adequately backed up.

3. SAFETY PRECAUTIONS

a. Responsibilities regarding safety precautions

- i. The relevant legal appointment should take reasonable measures to ensure that the *competent person* referred to in the guidelines is at all times aware of:
 1. *workings* which are being advanced;
 2. *surface structures* or objects which may be affected by mining;
 3. *workings* being abandoned or closed down, in order to allow the final surveying thereof;
 4. faces of *workings* being advanced within prescribed guidelines or any lesser distance determined by *risk assessment*, from any excavation, mining *restricted area* or any place where there is, or is likely to be, a dangerous accumulation of *fluid material*, noxious or flammable gas; and
 5. *safety pillars* that are being, or have been, removed.
- ii. The relevant legal appointment should ensure that –
 1. no mining operations are carried out under or within a horizontal distance as per prescribed guidelines, from buildings, roads, railways, *reserves*, mine boundaries, any structure whatsoever or any surface, which it may be necessary to protect, unless a shorter distance has been determined safe by *risk assessment* and all restrictions and conditions determined in terms of the *risk assessment* are complied with;
 2. where ground movement, as a result of mining operations, poses significant risk, an effective ground movement monitoring system is in place.
 3. no person may erect or construct any buildings, roads, railways, or any structure within a horizontal distance as per prescribed guidelines, from the *workings* of a mine, or such lesser distance and at such positions and subject to such restrictions and conditions, determined by – *risk assessment*; or the inspector of mines

- iii. The person(s) responsible for activities in terms of the guidelines should:
 - 1. in the case of the relevant legal appointment, provide the inspector of mines with the distance and accompanying restrictions and conditions for comment, prior to commencement of such activity;
 - 2. in the case of other persons, provide the inspector of mines with the distance and accompanying restrictions and conditions for approval, prior to commencement of such activity.
- iv. The relevant legal appointment should take reasonable measures to ensure that the relevant survey records and *plans* resulting from conditions described in the guidelines are updated by the *competent person* referred to in the guidelines at intervals not exceeding 3 (three) months.

b. Boundary Pillars

- i. The relevant legal appointment should ensure that on the inside of every mine boundary, continuous pillars are left standing (in situ) the width of which, measured horizontally and at right angles to the boundary line, should not be less than –
- ii. For underground mines, as prescribed by mining law and regulations;
- iii. For all other mines, as prescribed by mining law and regulations.
- iv. The relevant legal appointment should take reasonable measures to ensure that no boundary pillars are worked or cut through unless written permission has been obtained from all relevant adjacent relevant legal appointments and the inspector of mines.
- v. In the absence of any adjacent relevant legal appointment, permission need only be obtained from the inspector of mines to work or cut through such boundary pillars.

c. Check Survey

- i. Should the inspector of mines be of the view that there may be errors in any survey or *plans* constructed there from or where they do not

conform to the standards of accuracy required by these guidelines, such inspector of mines may cause a check survey to be carried out. The cost of such check survey should be borne by the relevant legal appointment if it is proved that there are errors in any survey or *plans* constructed there from, or that they do not conform to the standards of accuracy required by these guidelines.

4. SURVEY PRACTICE ON LAND (SURFACE AND UNDERGROUND) AND AT SEA

- a. The relevant legal appointment should take reasonable measures to ensure that in all surveying and mapping done and all plans prepared for purposes of these guidelines by the competent person referred to in the guidelines

b. Survey Stations

- i. Sufficient *survey stations* are established, so that all surface objects and all *workings* can be accurately surveyed. Each survey station should be clearly marked with a unique number and recorded in a register;

c. Standards of Accuracy: Surface and Underground

- i. the minimum standard of accuracy and class of survey for the fixing of *survey stations* on both horizontal and vertical planes are in accordance with the following formula:

$$A = 0,015 + \frac{S}{30\ 000}$$

where S is the distance in metres between the known and the unknown *survey station*; provided that in the case of a traverse, after a check survey has been completed, the error in direction of a line between any two consecutive *survey stations* should not exceed 2 (two) minutes of arc, provided that the horizontal and vertical displacement between the measured position and final position of a survey station does not exceed 0,1 (zero comma one) metres;

- ii. the allowable error for a primary survey (Class A) is not greater than A metres. Primary Survey means any survey carried out for the

- purpose of fixing shaft positions, shaft stations, underground connections, upgrading of secondary surveys to primary surveys and establishing primary surface survey control;
- iii. the allowable error for a secondary survey (Class B) is not greater than 1,5A metres. Secondary Survey means any survey carried out for the purpose of fixing main or access development, mine boundaries and establishing secondary surface survey control;
 - iv. the allowable error for a tertiary survey (Class C) is not greater than 3A metres. Tertiary Survey includes *survey stations* established from secondary *survey stations* for localised survey purposes;
 - v. the allowable error for a localized survey is not greater than 0,2 (zero comma two) metres in addition to the allowable error at the nearest *survey station*. Localized survey means measurements taken from a survey network to locate surface or underground *workings*, structures and features. This includes normal tape triangulation for month-end measurements, plugging, offsetting and tacheometric work;

d. Accurate Representation on Plan

- i. errors in representation on *plan* do not exceed 0,1% (zero comma one per cent) of the denominator of the scale of the *plan*, in addition to the allowable survey error at the nearest *survey station* or *fixed position*. Where the surveying cannot be accurately done due to significant risks, the estimated position of affected *workings* or objects should be indicated by broken lines. An explanatory note should be written giving reasons why accurate measurements could not be made;

5. MINE PLANS

a. Details required on Plans

- i. the following detail is depicted on all *plans* where applicable-
- ii. date of measurement of *workings*;
- iii. surface contours;

- iv. planes of sections or planes of *plans*;
- v. a subject heading indicating the name of the mine and the name of the *plan*;
- vi. name and signature of the *competent person* referred to in the guidelines against relevant date of updating;
- vii. identification number allotted by authorities;
- viii. the survey system and co-ordinates of origin used;
- ix. a north point;
- x. the scale of the *plan*;
- xi. a legend illustrating colours and conventional signs not provided for by the inspector of mines;
- xii. co-ordinate lines sufficient in number for the scale of the *plan* to be verified;
- xiii. in the case of mining at *sea*, the centre position of the sheet should be indicated in geographic co-ordinates (longitude and latitude);

b. Material and Size of the Plans

- i. all *plans* are drawn on durable transparent draughting material on sheets of a size not greater than A0 as defined by the International Organisation for Standardisation. The inspector of mines may request in the case of *plans* produced by means of computer aided draughting (CAD), that such *plans* be produced on suitable draughting material;

c. Scale of Plans – Land

- i. all *plans* are drawn to a scale of 1:1 500 in the case of a coal mine, and 1:1 000 in the case of any other mine; or as prescribed by mining law and regulations

d. Plans to be Kept Up to Date

- i. *plans* are at all times correct to within 12 (twelve) months, or as prescribed by mining law and regulations, except for the *plans* showing the *workings* which should at all times be correct to within 3 (three) months, or as prescribed by mining law and regulations. In the case of offshore prospecting and mining, *plans* should at all

times be correct to within 6 (six) months; or as prescribed by mining law and regulations

e. Inventory of Plans

- i. inventory of all *plans* and all copies called for in terms of the guidelines is kept, showing the following details –
 1. name of the mine;
 2. name and number of the *plan*;
 3. date of the last updating of the *plan* and the name of the *competent person* referred to in the guidelines;
 4. relevant details where a *plan* has been superseded; and

f. Superseded Plans

- i. When a *plan* or sheet is superseded by another *plan* or sheet, the old and the new *plan* are referenced accordingly.
- ii. The relevant legal appointment should take reasonable measures to ensure that the *competent person* referred to in the guidelines constructs accurate *plans*, as contemplated in the guidelines, which are readily available to the relevant legal appointment. Such *plans* should cover at least all *restricted areas* and the areas where the surface infrastructure or *workings* occur.

g. Index Key Plan

- i. A legible index key *plan*, showing the areas covered by the relevant *plan* sheets, the mine boundaries and the farm names and boundaries within and adjacent to the mine, or this detail may be shown on every *plan* sheet as an inset key *plan* drawn to a legible scale.

h. Surface Plan

- i. A *plan* of the surface showing the boundaries of the mining area, names of adjacent mining areas, the primary surface *survey stations*, outcrops and dips of the mineral deposits, perimeters of all surface mining, shafts, openings, rescue boreholes, subsidence or cavities, areas of restricted mining affecting the surface, any *hazardous services* whether on surface or buried and every surface object, structure or *reserve* which requires protection against mining.

i. Surface Contour Plan

- i. A surface contour **plan** showing relevant mine and farm boundaries, original surface contours, boreholes and watercourses.

j. Mine Ventilation and Rescue Plan

- i. At every underground mine, a ventilation and rescue **plan** of the **workings**, taking into consideration the requirements of the guidelines, drawn to a legible scale depicting the ventilation districts, the direction of air currents, the quantity of air circulating in such ventilation district and the position of each fan, door, regulator, crossing, stopping and telephone, the position of each refuge bay, rope-aided or normal escape route, safe place, first aid room, main water valve, fire fighting equipment site and any area sealed off for fire or spontaneous combustion.
- ii. A square grid, lettered horizontally and numbered vertically, drawn to a suitable scale should be shown on the **plan** contemplated in the guidelines.
- iii. An updated hard copy of the **plan** contemplated in the guidelines should be immediately available at the mine for rescue operation purposes. In the case of a coal mine, an updated hard copy should be submitted to the inspector of mines at intervals not exceeding 3 (three) months or as per the prescribed law and guidelines.

k. Rehabilitation Plan

- i. Rehabilitation **plan** showing the final surface contours and established water courses.

l. Mine Residue Deposit Plans

- i. Separate **plans** and sections of mine residue deposits containing **fluid material**.

m. Geological Plan

- i. A **plan**, drawn to a legible scale, depicting geological features that could affect mining or these features may be shown on the plan(s) referred to in the guidelines.

n. Plans of the Workings

- i. **Plans** of the **workings** showing the following: boundaries of the mining area; names of adjacent mining areas; outlines and dips of the **workings**; heights representative of **workings**; **survey stations**; relevant **survey points**; areas in which mining has been restricted or prohibited; dams; explosives magazines; lines indicating the planes of sections; faults; dykes and water plugs.
- ii. In the case of underground mines:
 1. Where a **bedded mineral deposit** has an average inclination to the horizontal of more than 60° (sixty degrees), a **plan** showing the projection of the **workings** onto a vertical plane parallel to the average strike.
 2. Where multiple **bedded mineral deposits** overlie each other, the **workings** thereof should be shown on separate **plans**.
 3. Where a massive or irregular ore body is worked, level **plans** and vertical sections through the **workings** should be kept.
- iii. In the case of surface mines:
 1. Where **bedded mineral deposits** are worked by surface mining methods, there should be shown on the surface **plan** sufficient data regarding the thickness and elevation of every mineral deposit worked in a suitable grid pattern. As an alternative to the grid pattern data, vertical sections may be kept, the lines of which should be indicated on the surface **plan**.
 2. Where massive or irregular mineral deposits are worked, level **plans** or vertical sections or a composite **plan** showing all the bench outlines, should be kept.

o. Level Plans and Vertical Sections

- i. Level **plans** should show the outline of all **workings** at suitably chosen elevations. In the case of underground mines, the detail required in the guidelines should be shown.

- ii. Vertical sections should be drawn through the *workings* shown on the *plans* contemplated in the guidelines to show the appropriate detail required for level *plans*.

p. General Plan – Mining on Land

- i. A general *plan* should be constructed, showing the detail required in the guidelines on one *plan* instead of on three separate *plans*, or a general surface *plan* showing the detail required in the guidelines on one plan instead of on two separate plans.

q. General Plan – Mining at Sea

- i. A general *plan* should be constructed showing the boundaries of the mining area, the names of adjacent mining areas and the locality of semipermanent production rigs and platforms.

r. Departmental copies of plans

- i. The relevant legal appointment should provide the inspector of mines annually with updated copies of the *plans*. In the case of computer aided draughting (CAD), legible *plans* in book form or a copy of the index key *plan* referred to in the guidelines, indicating additionally the outlines of the *workings* as well as the surface infrastructure, and a copy of the back-up referred to in the guidelines should be provided.

s. Unsatisfactory Plans

- i. Where *plans* are deficient, the inspector of mines may have the mine surveyed and new *plans* prepared at the expense of the relevant legal appointment.

t. Plans Confidential

- i. The inspector of mines should keep information contained in any *plan* confidential and may only release such information in accordance with the prescribed law and.

6. MINE CLOSURE

a. Plans brought up to Date

- i. The relevant legal appointment should take reasonable measures to ensure that, before a mine is abandoned, closed or rendered inaccessible, the *plans* and departmental copies thereof referred to in the guidelines are brought up to date by the *competent person* referred to in the guidelines and that the inspector of mines is notified to inspect such *plans* for approval.

b. Plans and Books to be Handed In

- i. The relevant legal appointment should take reasonable measures to ensure that updated hard copies of the *plans*, copies referred to in the guidelines and inventories thereof on durable draughting material, together with the *survey station* register are handed in at the office of the inspector of mines, following the inspection and approval of the *plans* as contemplated in the guidelines.

c. Certificate of compliance

- i. The inspector of mines should issue a certificate of compliance with the requirements of the guidelines to the relevant legal appointment within 60 (sixty) calendar days of compliance in respect of the said guidelines, or as per the prescribed law and guidelines.

APPENDIX B TEMPLATES

Summary of key components

Key component	Description	Review mechanism
Health of Survey discipline	<ul style="list-style-type: none"> • Number of surveyors - (qualifications and experience) • Succession plans – (timelines and gaps) • Feedback from line manager - (Technical) • Stability of discipline - (flight risks) • Knowledge sharing forum - Formal technology/knowledge scanning mechanism? • Strategic leadership 	Demonstrated via reports, charts and minutes
Survey Manager risk log and profile	<ul style="list-style-type: none"> • General compliance – (adherence to local and international codes and acts) • Existence of standards, guidelines and procedures – (demonstrable use of both) 	Interrogate downloaded acts and codes. Review samples of guidelines and procedures
CADD assurance	<ul style="list-style-type: none"> • Draughting standards - (process and guidelines) • Database management and standards – (3D spatial control) 	Review samples of guidelines and procedures. Complete check list. View and review 3D spatial environment
Survey assurance	<ul style="list-style-type: none"> • Data capture and computation - (process and guidelines) • Standards – (procedures, guidelines and acts) • Limits of error – (corporate standards) check surveys) 	Review samples of guidelines and procedures. Complete check list. Demonstrate capture and computation. Table check survey results
Ore Accounting assurance	<ul style="list-style-type: none"> • Flow of ore reconciliation – (tonnage and content balances) • Resource and reserve - (integration and adjustments) • Factors - (modifying figures and results) 	Demonstrate depletion process. Complete check list. Confirm data integrity. Review ore accounting methods
Levels of work – house model	<ul style="list-style-type: none"> • Zachmans model for the discipline - (review levels of work and match to current structure) 	Compare levels in the section to theory.
Individual profile	<ul style="list-style-type: none"> • Competence levels, training and development - (qualifications and experience) 	Review all.
Legal compliance	<ul style="list-style-type: none"> • Compliance to legal inspection criteria - (check list) • Pertinent legal knowledge and compliance - (understand the law enough to operate beyond compliance-mode?) 	Confirm all compliance to acts and codes. Complete check list
Integration of Survey with other technical disciplines	<ul style="list-style-type: none"> • Rock Engineering – (pro-active or reactive engagement and monitoring.) • Other Technical Services - (geology, mine planning, environmental) • Effectiveness of engagement and understanding of co-dependence of Technical Services disciplines 	Discuss and table list of clients and service delivery. Depth of understanding of Risk and effective Mitigation. Effective analysis of measurement data, opinion and reporting of movement monitoring information

Legal register hierarchy

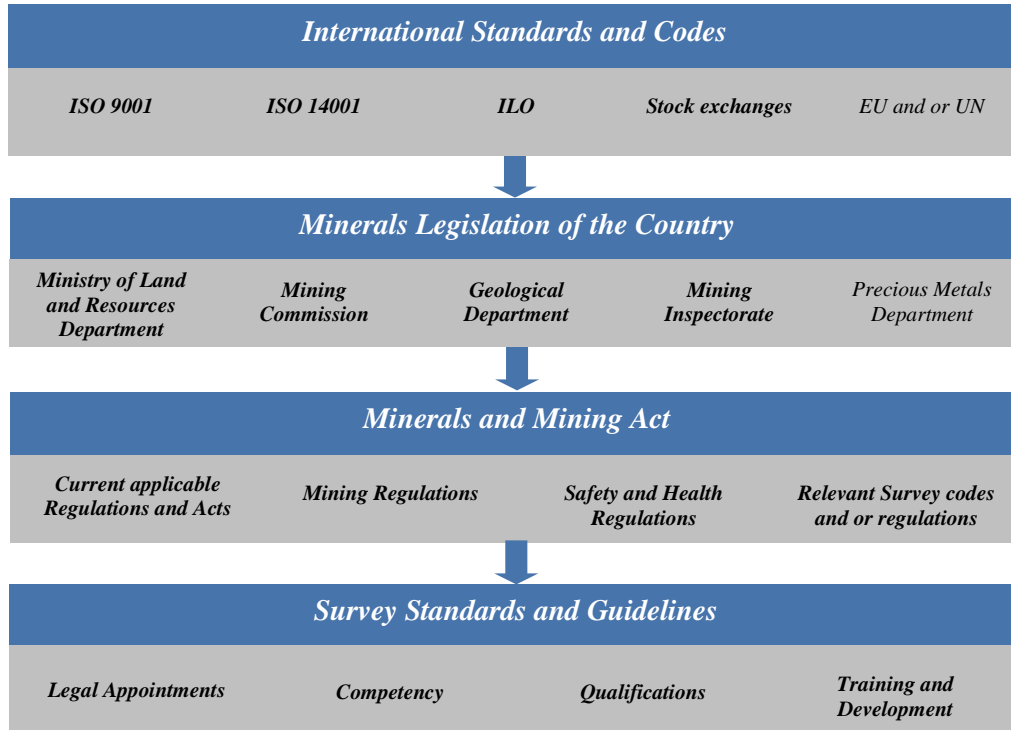

Responsibility check list

	Key references	The Owner	The Manager	The Plant Manager	The Environmental Manager	The Surveyor
Ministry of Lands and Natural Resources	responsibility for resources					
Ministry of Mines and Energy	responsibility for the mining					
Minerals Commission	recommends mineral policy					
Geological/ Survey Department	map production and maintenance of geological records					
Mines Department	health and safety inspections and maintenance of mining records					
Lands Commission	legal records of licenses and legal examination of new applications					
Chamber of Mines	association of representatives of mining companies					
Environmental Protection Agency	overall responsibility for environment					

International review for compliance

International register Reference	Ghana
Regal and/or Presidential Rule	The King is a traditional and integral part of the country. The minerals of the country are vested in The President, in trust for the people.
Ore Reserves and Mineral Resources	Mineral Resources and Ore Reserves conform to the JORC Code, 2004 edition as well as to the standards set out in the South African Code for the Reporting of Mineral Resources and Mineral Reserves (the SAMREC 2000 Code).
ISO 14001	Environmental Management System (EMS) certified to the ISO14001 standard.
ILO	The Company is committed to upholding the Fundamental Rights Conventions of the International Labour Organisation (ILO),
Applicable Stock Exchanges	AngloGold Ashanti's primary listing is on the JSE (Johannesburg Stock Exchange). It is also listed on exchanges in New York, London, Paris, Brussels, Australia and Ghana.
EU and UN	<ul style="list-style-type: none"> • United Nations Global Compact (UNGC) • International Council on Mining and Metals (ICMM) • Responsible Jewellery Council (RJC) • Global Reporting Initiative (GRI) • Extractive Industries Transparency Initiative (EITI) • International Cyanide Management Code for the manufacture, transport and use of cyanide in the production of gold (Cyanide Code)(ICMI)
OHSAS 18001	OHSAS 18001: The Occupational Health and Safety Assessment Series, presents requirements for an occupational health and safety management system.
World Health Organisation (WHO)	AngloGold Ashanti's malaria programmes and protocols are based on World Health Organisation (WHO) standards
King Report/King 2	It is the policy of the AngloGold Ashanti Group to comply with the King Report on Corporate Governance of South Africa 2002 where the Company deems it appropriate.
Sarbanes-Oxley (SOx)	Sarbanes-Oxley Act of 2002 – introduced into law in the United States to set new corporate governance standards for corporate boards and accountability standards and penalties for corporate management.

Company Group register

<i>Country register References</i>	Ghana	Guinea	Mali	Namibia	Tanzania
Mine Health and Safety	Health and Safety falls under the Mining Act	Title holder to draw up regulations	Reference to Safety and Health in the Code	Mine Health and Safety Regulations (10th draft)	Mining (Safe Working and Occupational Health), 1999
Minerals Act and or Mining Act	Minerals and Mining (Amendment) Act of 1994 (Act 475) - Minerals and Mining Law, 1986 (PNDC Law 153) amended to The New Minerals and Mining Act 703, 2006	Guinea\Country specific Register\Guinea Code 1995	Mining Code - Order No 99-032/P-RM of Aug 19, 1999 Mining Act	Minerals (Prospecting and Mining) Act, 1992 (Act No 33 of 1992)	Mining Act Cap. 123, Section 5 (50 of 1991), Mining Act 1998
National Water Act	Rivers Ordinance (Cap 226)	Reference to underground water issues in the Code	National Water Regulator referenced in the Code	Territorial Sea and Exclusive Economic Zone of Namibia Act, 1990 (Act 3 of 1990)	National Water Act (36 of 1998)
Land Survey Act	Under the Lands Commission there is a Land Survey Department	None found	Director of Mapping and Survey and references in the Code	Townships and Division of Land Ordinance, 1963	Land Survey Act (8 of 1997)
Environmental Management Programme	ISO14001 - Ghana's Environmental Protection Agency (EPA)	Environmental Management and Protection Regulation of 1999	Environmental code	Environmental Management Act of 2007 (EMA)	Environment Management Act, 2004
Precious metals or stones (export of minerals)	Diamonds [Amendment] Law 1989 (PNDCL 159)	Reference to precious metals and stones in the Code	Reference to precious metals and stones in the Code	Diamond Act, 199 (Act No 13 of 1999)	Mining (Mineral Trading) Regulations, 1999
Investment act	Extractive Industries Transparency Initiative (EITI)	Reference to investment in the Code	Convention for the Settlement of Investment disputes	Minerals Development Fund of Namibia Act 1996 (Act 19 of 1996)	Tanzania Investment Act, 1997
Mining Regulations and rules	Ghanaian Mining Regulations of 1970 (LI 665, LI 666)	Mining Act 1998 - Convention de Base (for Mines and Quarries)	Reference to Mining Regulations in the Code	Mines, Works and Minerals Ordinance 20 of 1968	Mining (Dispute Resolutions) Rules, 1999

Survey Managers/Chief Surveyors check list

<i>Key performance indicators for Chief Surveyors</i>	Section	Ghana
General Requirements	Relevant legal/competent appointment <i>(reference country law or on mine regulations)</i>	
	Area of responsibility (mining right) <i>(mining area and mining right plans)</i>	
	Survey System <i>(local and global with constants and transformation criteria)</i>	
	Survey network <i>(underground and or surface configuration)</i>	
	Survey records <i>(all data captured, calculated and drafted to be retained)</i>	
Safety Precautions	Workings being advanced <i>(all surface and underground working face positions)</i>	
	Ground movement monitoring system <i>(surface subsidence control and data analysis)</i>	
	Surface structures or objects <i>(mining activities relative to :-)</i>	
	Boundary and safety pillars <i>(mining activities relative to :-)</i>	
	Check survey <i>(closures in azimuths, coordinates and elevation)</i>	
Survey Practices	Survey stations <i>(construction, accuracies and uses)</i>	
	Standards of accuracy <i>(limits of error in all levels and types of survey for underground and surface)</i>	
	Accurate representation on plan <i>(scale and projection to be considered)</i>	
Mine Plans	Details required <i>(name of mine, title block and legend etc)</i>	
	Plans to be kept up to date <i>(responsible persons signature and date of update)</i>	
	Inventory of plans <i>(all plans including superseded plans)</i>	
	Types of plans <i>(level plans, sections, rehabilitation, contour and other legislated plans required)</i>	
	Departmental copies <i>(legal submissions required)</i>	
Bill of quantities	Quality ore accounting with audit trails <i>(flow of ore and waste system)</i>	
	Accurate measurement of extraction of the ore body <i>(surveyed volumes and tonnes)</i>	
	Integrated and dynamic auditing cycles for ore and waste accounting <i>(weekly, monthly and annual reconciliation of all ore and waste)</i>	
	Integration and application of technology <i>(one version of the base data entry)</i>	
	Reduction in risk in resources and reserves <i>(second party checks on all data at all levels)</i>	

Example of guideline register

On mine chapters and guidelines	Mine A	Mine B	Mine C	Mine D	Mine E
On Mine codes or SOP	Ghana\Chapters and guidelines\Standard Instruction1	<i>Not available yet</i>	Survey House Keeping Procedures	<i>Not available yet</i>	Mining (Safe Working and Occupational Health),1999
Responsibility/ Service level agreement					√
Survey history					√
Reference and compliance list					√
Terms and definitions			√		√
Safety and Health					√
Origin/point of departure /bench mark	√				√
Transformation					√
Accuracy and network classification	√				√
Communication	√		√		√
Computation	√		√		√
Beacons					√
Ground movement monitoring					√
Care and maintenance of equipment	√		√		√
Aerial surveying					√
Terrestrial scanning					√
Shaft surveying		NA	NA	NA	NA
Underground surveying	√	NA	NA	NA	NA
Surface surveying					√
Mine plans	√				√

The review process

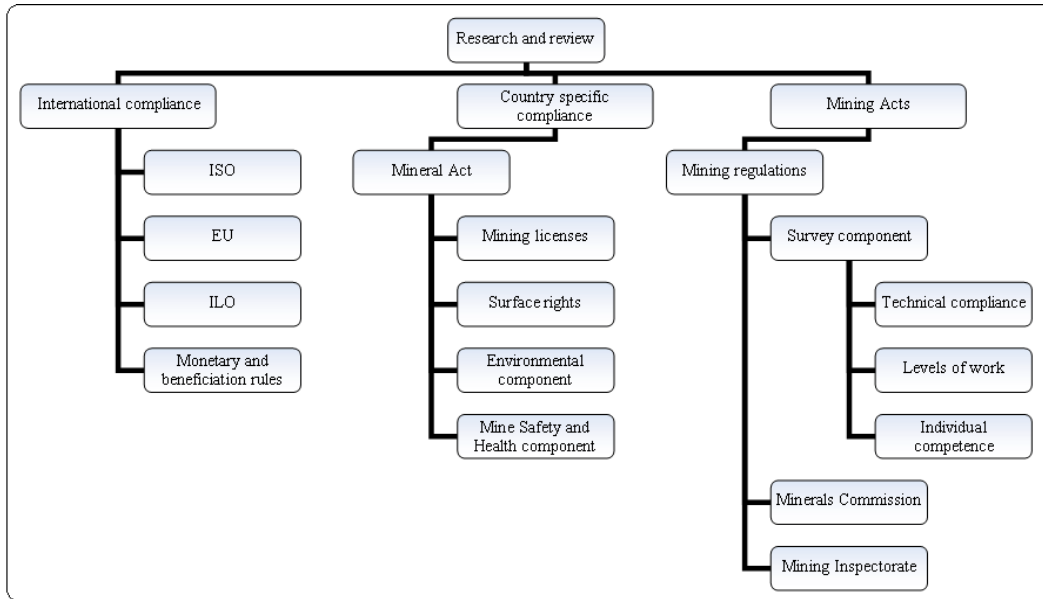

Example of an audit sheet

SURVEY ASSURANCE Mine

KEY PERFORMANCE AREA		CRITICAL SUCCESS FACTOR	TARGET	STRETCH TARGET	ACTUAL SCORE	COMMENTS	NEXT STEPS
DATA CAPTURING	1.1	Are all survey stations and points captured according to procedure	3	5	4.0		
	1.2	Are all the necessary checks and balances adhered to	3	5	3.0		
	1.3	Are the monthly tonnage surveys - GPS/total via photogrammetry performed	3	5	4.0		
	1.4	Is there robust base data capture for survey instruments' data	3	5	4.0		
	1.5	Are all surveys captured within the "limits of error"	3	5	4.0		
	1.6	System security	3	5	4.0		
		Average:	3.0	5.0	3.8		
DATA MANAGING	2.1	Are all survey stations and points managed according to procedure	3	5	4.0		
	2.2	Are all the necessary checks and balances adhered to	3	5	4.0		
	2.3	Is there robust base data managed for survey instruments' data	3	5	3.0		
	2.4	Are all surveys computed within the "limits of error"	3	5	4.0		
	2.5						
		Average:	3.0	5.0	3.8		
DATA REPORTING	3.1	Is all survey information available to relevant stakeholders?	3	5	4.0		
	3.2	Is all survey work formally documented?	3	5	4.0		
	3.3	Is there a robust system and data administration in place	3	5	3.0		
	3.4						
		Average:	3.0	5.0	3.7		
LAND MANAGEMENT	4.1	Is there participation in the EMPR and/or rehabilitation programs	3	5	4.0		
	4.2	Are all water courses and re-vegetation on plan	3	5	4.0		
	4.3	Are all cables plotted	3	5	3.0		
	4.4	Are the Mining Rights boundaries plotted and shown on plan	3	5	4.0		
	4.5	Are all features and structure elevations shown on plan	3	5	4.0		
		Average:	3.0	5.0	3.8		

Mine Surveyor:

Group Surveyor:

Date:

Results from an audit

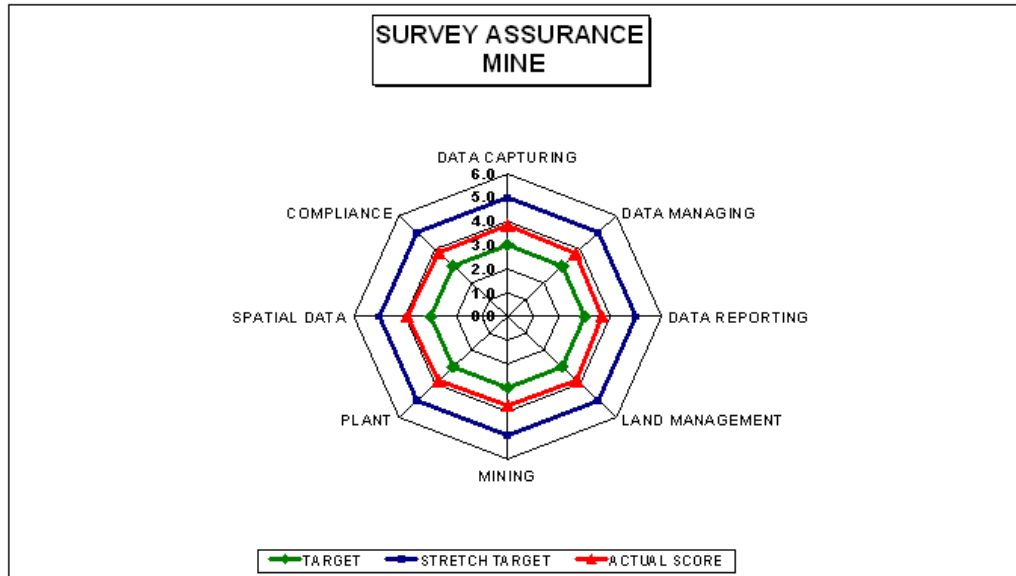

Levels of work in a survey section

	What (Things)	How (Processes)	Where (Location)	Who (People)	When (Temporal)	Why (Motivation)
Planner model (contextual)	<i>Quality assurance of the accurate measurement of extraction or the ore body</i>	Accurate Spatial data Capture External audit Internal audit	Mine	Mine	Annual	Annual report Acquisition of capital expenditure
Owner model (conceptual)	Quality design of all ore body models	Secure integrated databases	Relevant management structure	Relevant management structure	Annual	Samrec code of practice Legal compliance
Designer model (strategic)	Accurate depletion of ore models	Photogrammetry GPS General surveying methods	Survey	Chief Surveyor/ Survey Manager	Quarterly	Actual depletion and production results, strategic, short and long term plans
Builder model (tactical)	Accurate design and depletion of surfaces and excavations	Photogrammetry GPS Laser Design General Traverse	Survey	Section Surveyor	Monthly	Creation of 3D digital and spatial models
Sub-contractor model (operational)	Quality level plans and 3 D models	Digital photos Tachometry GPS Mine design	Pit, surface underground	Production and development surveyors	Monthly	Capture spatial data
Product model (execution)	Accurate level plans	Leveling, traverse tachometry	Pit, surface underground	Production Development Stockpiles Technical surveyors	As and when required.	Capture spatial data

Compliance review work streams

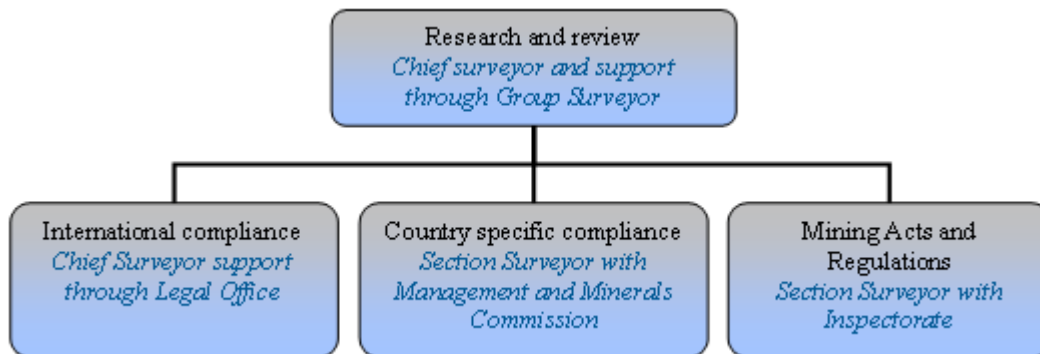

Example of project time frame

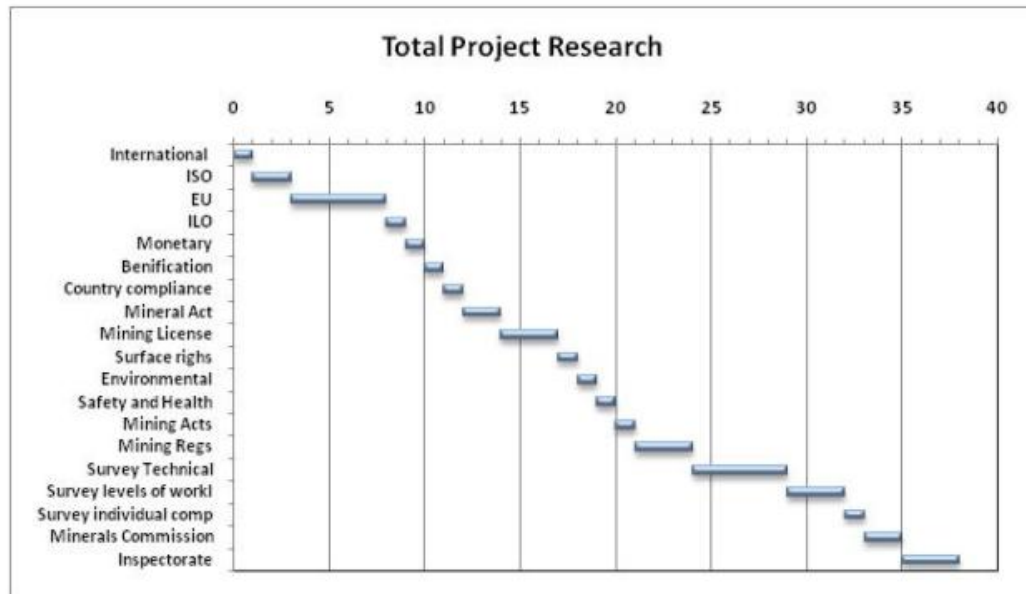

Individual Capability

Abridged CV (to be completed by the employee)			
INDIVIDUAL CAPABILITY (High level, detail only)			
Name:			
Job Title:			
Division/Department:		Company:	
Grade:	Age:	Service:	
Languages:		Educational Qualifications:	
<ul style="list-style-type: none"> • • • 		<ul style="list-style-type: none"> • • • 	
Career History (include pre-AGA experience)			
<i>From</i>	<i>To</i>	<i>Job title</i>	<i>Company</i>
Accomplishments/Achievements:			
<ul style="list-style-type: none"> • • • 			
Date completed/updated:			

Individual Profile

Group Service:				
Service in current position:				
Name:		Current pipeline role:		
Job title:				
Grade:		Operating at correct level?	Yes	No
Strengths:	Accomplishments:	Performance:		
▪	▪	Potential:		
▪	▪	<i>As per 9 box</i>		
▪	▪			
Qualifications:		Development needs:		
▪		▪		
▪		▪		
▪		▪		
Possible positions: (Are these aligned to the employees aspirations?)				
Short term (1-3 years):	Medium term (3-5 years):	Long term (5-10 years):		
▪	▪	▪		
▪	▪	▪		
▪	▪	▪		
Mobility restrictions:		Date completed:		

9 Box

3 Year PERFORMANCE (Track record and behaviours)				
		Exceptional	Full	Not yet full
POTENTIAL (Stretch and personal orientation)	Turn			
	Growth			
	Mastery			

Future Leaders are likely to be found in these boxes, focus on development	Key Contributors , focus on performance to ensure continued value is added	Under performers , rigorous performance management required
---	---	--

Succession planning Template

Complete a separate template with successors for yourself and each of your subordinates. Indicate which positions you consider to be mission-critical and high-impact positions by using the colours indicated below

Position	Name	Gender	Nationality
1. Ready now candidates (ready within 1 year)*			
2. Ready later candidates (ready within 2-3 years)*			
3. Candidate from outside the function*			