

**The Middle and Later Stone Age crystal quartz technologies of Pomongwe  
Cave, Matopos (Zimbabwe).**

**By**  
**Matembo Joseph**  
**(1747657)**



Dissertation submitted to the Faculty of Science, University of Witwatersrand in  
fulfilment of the requirements for the Degree of Master of Science in  
Archaeology

July 2019

**DIVISION OF ARCHAEOLOGY**  
**SCHOOL OF GEOGRAPHY, ARCHAEOLOGY AND**  
**ENVIRONMENTAL STUDIES**

## **DECLARATION**

I, **Joseph Matembo**, declare that this dissertation is my own original work. It is being submitted for the degree of Master of Science, at the University of the Witwatersrand, Johannesburg. It has not been submitted to any other academic institution for any degree or examination.

A handwritten signature in black ink, appearing to read 'J. Matembo', is centered on the page. The signature is written in a cursive style with a horizontal line underneath.

Joseph Matembo

08<sup>TH</sup> of July 2019.

## **ABSTRACT**

The study examines the technology of crystal quartz pieces from Pomongwe Cave (PMG), Matopos, and south-western Zimbabwe. It focuses on the Middle and Later Stone Age (MSA and LSA) assemblages, which were excavated in the early 1960s by C. K Cooke and is housed at the Zimbabwe Museum of Human Sciences (ZMHS) in Harare. The research employs the *chaîne opératoire* approach to the study of crystal quartz technology, which follows all the stages of lithic production from the sourcing of the raw material through exploitation, use and discard patterns. It seeks to understand how the hunter-gatherers at Pomongwe (PMG hereafter) exploited this material and how they adapted their technologies to suit the physical and mechanical properties of crystal quartz through time at the site. On a broader scale, the study contributes to our understanding of the development of Modern Human Behaviours (MHBs). The results of the study show that the sourcing of the crystals was mainly from a secondary context throughout the MSA and LSA sequence. The presence and distribution of the material also varied throughout the MSA and LSA sequence, suggesting that the raw material was more prominent with the inhabitants during certain periods than others. The results through classification also show that not all collected crystals were exploited for lithic production, which raises questions as to why they were collected. The cores and blanks show that the crystals were mainly opened from the pyramid and exploited going towards the base of the crystal. The most notable change in the exploitation of crystal quartz throughout the MSA and LSA sequence at PMG is that of the reduction in the sizes of the blanks going towards the LSA.

**Key Words:** crystal quartz; Modern Human Behaviour; lithic technology; *chaîne opératoire*; Middle Stone Age; Later Stone Age; Pomongwe.

## **ACKNOWLEDGEMENTS**

This dissertation would not have come to fruition, if it was not for the funding I received from PAST. I would like express my sincere gratitude to the body for giving me the grant and allowing me to pursue my studies. The grant went a long way in the fruition of this research and finally the production of this dissertation.

I would also want to extend my gratitude to the Directors of the MATOBART project, Dr C. Bourdier (University of Toulouse Jean Jaures, France) and Dr G. Porraz (CNRS, University of Paris Ouest, France); for granting me the opportunity to be part of this project. It was such an honour to work on Pomongwe in collaboration with the University of Zimbabwe and National Museums and Monuments of Zimbabwe staff.

To my supervisors, Professor K. Sadr and Dr G. Porraz, words alone cannot do justice. I thank you so much for your time in the formulation and moulding of this research. Your guidance was very much appreciated. I would also want to express my gratitude to the Proposal Committee team for their comments and constructive criticism during my proposal presentation. To Dr de la Pena, thank for the discussions we had on crystals quartz and its exploitation at Sibudu.

Heartfelt appreciation is also extended to the NMMZ Director Dr G. Mahachi and the ZMHS, for allowing me to carry out my research at the museum premises though it was tough at times. Many thanks go to the Archaeology department at the museum namely Dr H. Marufu, Ms T. Makwabarara, and Mr F. Munetsi; for their time and efforts to make sure that I got access to the collections which was often a challenge. Also to mention the help I received from the student attachees Hope T. Chakanetsa, Delight Veterai and Steven Mugarisi, I thank you very much guys.

I would also like to thank my colleagues, Jonathan Nhunzvi, Precious Chiwara-Maenzanise, Thubelile Mkandla and Joshua Kumbani, for the support and encouragement. Precious thank you for the fruitful discussions we had over this research and working together during the time of our analyses at the ZMHS. Josh and Jona thanks for the brotherly love and continued motivation which made me pull through.

I also extend my acknowledgements to all my family members for being there for me and giving me the much needed moral support. Mum I thank you for all the prayers, unwavering support and having faith in me during my academic career. During the course of this study I got to meet the one person who became my motivation and my pillar of strength. She provided me with all the love, support and encouragement to push on no matter how hard things seemed. I am greatly indebted to my lovely lady Hope T. Chakanetsa.

# **Table of Contents**

DECLARATION .....	i
ABSTRACT.....	ii
ACKNOWLEDGEMENTS .....	iii
LIST OF FIGURES. ....	viii
LIST OF TABLES.....	ix
LIST OF ABBREVIATIONS .....	x
CHAPTER ONE .....	11
1. Introduction.....	11
1.1. Background information .....	11
1.2. Research Aims .....	18
1.3. Research Objectives.....	18
1.4. Research Questions.....	18
1.5. Rationale .....	19
1.6. Dissertation Outline .....	20
CHAPTER TWO .....	21
2. Research Area .....	21
2.1. Introduction.....	21
2.2. Matopos Landscape .....	21
2.2.1. Physiography.....	22
2.2.2. Climate .....	23
2.2.3. Vegetation .....	24
2.2.4. Fauna.....	24
2.3. Zimbabwean Stone Age sequence .....	24
2.4. Archaeology of the Matopos.....	31
2.5 Pomongwe Cave .....	31
2.5.1. The Archaeology of Pomongwe .....	32
CHAPTER THREE .....	40
3. Literature Review.....	40
3.1. Introduction.....	40
3.2. Quartz Raw Material Studies .....	40
3.3. Crystal Quartz Exploitation: Worldview .....	42
3.4. Lithic Technology and crystal quartz: A State of the Art in Southern Africa .....	44
CHAPTER FOUR.....	47

4. Materials and Methods.....	47
4.1. Introduction.....	47
4.2. Materials .....	47
4.2.1. Physical Properties.....	48
4.2.2. Morphology.....	50
4.3. Sample Selection.....	57
4.4. Problems Faced.....	60
4.5. Methods.....	60
4.5.1. <i>Chaîne Opératoire</i> Approach.....	60
4.5.2. Identification .....	64
4.5.3. Natural Surface .....	64
4.5.4. Integrity.....	64
4.5.5. Reduction Strategies .....	65
4.5.6. Technique.....	68
CHAPTER FIVE .....	69
5. Study Results .....	69
5.1 Introduction.....	69
5.2 Sample size .....	69
5.3. Crystal quartz general attributes .....	70
5.3.1. Diaphaneity .....	70
5.3.2. Inclusions .....	70
5.3.3. Natural Surface .....	72
5.4. Classification of the crystal quartz pieces.....	73
5.5. Unmodified Crystals .....	75
5.6. Modified crystals .....	81
5.6.2. Cores .....	84
5.6.3. Tools .....	85
5.6.4. Technique.....	87
5.7. Blanks .....	88
5.7.4. Platform Analysis.....	92
5.7.5. Platform Dimensions.....	93
5.7.6. Technique.....	94
5.7.7. Functional Scars.....	95
5.8. Reduction Strategies. ....	96

CHAPTER SIX.....	99
6. Discussion.....	99
6.1. Introduction.....	99
6.2. Sample variation.....	100
6.3. Raw Material.....	101
6.4. Natural Surface.....	102
6.5. Technical Variation.....	102
6.5.1. Unmodified Crystals.....	102
6.5.2. Modified Crystals.....	104
6.5.3. Blanks.....	106
6.6. Functional variation.....	108
6.7. Techno-economic Approach.....	109
7. CHAPTER SEVEN.....	111
7.1. Conclusion.....	111
7.2. Recommendations.....	113
REFERENCE LIST.....	114

## **LIST OF FIGURES.**

FIGURE 1: EXAMPLE OF CRYSTAL QUARTZ PIECES FROM DIFFERENT LAYERS AT POMONGWE LAYERS. PICTURE MODIFIED AFTER COOKE (1963).....	17
FIGURE 2: PHYSIOGRAPHIC SETTING OF THE MATOPOS PICTURE BY J. MATEMBO. ....	22
FIGURE 3: GEOLOGICAL MAP OF THE MATOPOS WORLD HERITAGE LANDSCAPE, SHOWING ARCHAEOLOGICAL SITES AND THE VARIABLE TOPOGRAPHY. (AFTER HUBBARD) .....	23
FIGURE 4: MAP SHOWING STONE AGE SITES IN ZIMBABWE MENTIONED IN THIS MANUSCRIPT.....	26
FIGURE 5: POMONGWE CAVE PICTURE BY G. PORRAZ .....	32
FIGURE 6: PLANIMETRY OF POMONGWE, SHOWING THE FIVE TRENCHES SUNK AT THE SITE (TRENCH I TO III ARE COOKE'S EXCAVATIONS, TRENCH IV AND V ARE WALKER'S EXCAVATIONS). THE AREA ENCIRCLED IN RED IS THE LOCATION OF THE AREA UNDER STUDY (AFTER WALKER1995).....	33
FIGURE 7: STRATIGRAPHIC PROFILE FROM TRENCH I OF COOKE, SHOWING THE EASTERN SECTION OF THE TRENCH. NUMBER OF LAYERS IN CIRCLES (AFTER COOKE 1963). ....	35
FIGURE 8: CONSTANT CHARACTERS OF NATURAL CRYSTAL QUARTZ. ....	48
FIGURE 9: CRYSTAL SYSTEM OF CRYSTAL QUARTZ.....	51
FIGURE 10: CRYSTAL QUARTZ FROM POMONGWE CAVE SHOWING PRISMS WITH VARIOUS MORPHOLOGIES A) N <sup>o</sup> . 208, LAYER 14; B) N <sup>o</sup> . 188, LAYER 13; C) N <sup>o</sup> . 224, LAYER 12 AND D) N <sup>o</sup> .185, LAYER 13.....	54
FIGURE 11: COOKE'S TRENCH I RE-OPENED IN 2018 (PICTURE BY J. MATEMBO).....	57
FIGURE 12: THE INTEGRITY OF THE CRYSTALS AND BLANKS. ....	65
FIGURE 13: THE ALPHA-NUMERIC SCHEME DESIGNED FOR THE TECHNOLOGICAL ANALYSIS OF CRYSTAL QUARTZ. THE LETTERS PROVIDE THE STAGES AND DEVELOPMENT OF THE REMOVALS WITHIN THE GEOMETRY OF THE CRYSTAL; THE NUMBERS REPRESENT THE DIRECTION OF THE REMOVALS ACCORDING TO THE NATURAL AXIS OF THE CRYSTAL. ....	67
FIGURE 14: DIAGRAMS SHOWING MAIN DEBITAGE PRODUCTS A) TRANSVERSAL FRAGMENTATION OF THE PRISM, B) PRISM THINNING, C) CORTICAL REMOVAL AND D) DEBITAGE PRODUCTION (AFTER SAUTER ET AL 1971). ....	68
FIGURE 15: CHART SHOWING CRYSTAL QUARTZ INCLUSIONS FREQUENCIES.....	71
FIGURE 16: RESULTS OF THE NATURAL SURFACE EXAMINATION PER LAYER. ....	72
FIGURE 17: SHOWING THE PERCENTAGE OF THE DIFFERENT CATEGORIES OF THE SELECTED CRYSTALS. ....	73
FIGURE 18: UNMODIFIED CRYSTAL QUARTZ PIECES FROM DIFFERENT LAYERS, I.E. A) LAYER 3, N <sup>o</sup> 57; B) LAYER 3, N <sup>o</sup> 4; C) LAYER 11, N <sup>o</sup> 92 AND D) LAYER 19 N <sup>o</sup> 257. ....	75
FIGURE 19: SHOWING THE PERCENTAGE OF EACH SCARRING LOCATION. ....	80
FIGURE 20: RESULTS OF THE PATTERNS OF SCARS PER LAYER (65 PIECES WERE CONSIDERED IN TOTAL THROUGHOUT THE SEQUENCE.....	81
FIGURE 21: MODIFIED CRYSTALS FROM DIFFERENT LAYERS, I.E. A) LAYER 3, N <sup>o</sup> 31; B) LAYER 10, N <sup>o</sup> 41; C) LAYER 22, N <sup>o</sup> 301; D) LAYER 3, N <sup>o</sup> 49; E) LAYER 11, N <sup>o</sup> 68 AND LAYER 3, N <sup>o</sup> 11. ....	82
FIGURE 22: FREQUENCIES OF THE MODIFIED CRYSTALS PER CATEGORY PER LAYER.....	83
FIGURE 23: BLANKS RECOVERED FROM THE VARIOUS LAYERS, I.E. A) FROM LAYER 3, N <sup>o</sup> 17; B) LAYER 22, N <sup>o</sup> 300; C) LAYER 24, N <sup>o</sup> 308 AND D) LAYER 4-6, N <sup>o</sup> 15.....	88
FIGURE 24: SHOWING THE FREQUENCIES OF EACH BLANK CATEGORY. ....	89
FIGURE 25: PLATFORM TYPES FREQUENCIES.....	92
FIGURE 26: PLATFORM TYPE FREQUENCY PER LAYER ON ALL THE BLANKS (N=257). ....	93
FIGURE 27: TECHNIQUES EMPLOYED ON THE BLANKS.....	94
FIGURE 28: PERCENTAGE OF EACH KNAPPING TECHNIQUE PER LAYER.....	95

## **LIST OF TABLES.**

TABLE 1: TRAITS USED TO IDENTIFY MODERN HUMAN BEHAVIOURS (MODIFIED AFTER HESHILWOOD & MAREAN 2003, WADLEY 2015). .....	12
TABLE 2: SOUTHERN AFRICAN MSA AND LSA CHRONO-CULTURAL FRAMEWORK (ADOPTED FROM LOMBARD ET AL 2012; WADLEY 2015). .....	16
TABLE 3: ZIMBABWEAN MSA AND LSA SEQUENCE IN CORRESPONDENCE TO SOUTHERN AFRICA (FOLLOWING WALKER AND THORPE 1995, LOMBARD ET AL. 2012) .....	30
TABLE 4: TRENCH I STRATIGRAPHY. NB: LAYERS MARKED IN YELLOW HAD NO CRYSTALS RECOVERED AND LAYERS 1 & 2 WERE NOT INCLUDED IN THIS STUDY.....	36
TABLE 5: SOME MSA AND LSA SITES IN SOUTHERN AFRICA WHERE “CRYSTAL QUARTZ” HAVE BEEN MENTIONED. ....	46
TABLE 6: SEVEN CLASSES CRYSTAL SYSTEMS.....	51
TABLE 7: CRYSTALLOGRAPHIC CHARACTERISTICS OF QUARTZ (CRYSTAL QUARTZ). ....	56
TABLE 8: SHOWING THE PROPORTIONS OF EXPLOITED RAW MATERIALS IN SQUARE X: C1-3...59	
TABLE 9: FREQUENCIES OF THE CRYSTAL QUARTZ DIAPHANEITY PER LAYER. ....	70
TABLE 10: FREQUENCIES OF COLOUR INCLUSIONS ON THE CRYSTAL QUARTZ PER LAYER.....	72
TABLE 11: THE DIFFERENT CATEGORIES OF CRYSTAL QUARTZ PER LAYER THROUGHOUT THE SEQUENCE.....	74
TABLE 12: RESULTS OF THE INTEGRITY OF UNMODIFIED CRYSTALS PER LAYER.....	77
TABLE 13: DIMENSIONAL RANGES OF THE UNMODIFIED CRYSTALS. ....	78
TABLE 14: PYRAMID MORPHOLOGY RESULTS PER LAYER.....	79
TABLE 15: SHOWING THE RESULTS OF THE LOCATION OF SCARS PER LAYER. ....	80
TABLE 16 : MODIFIED CRYSTALS DIMENSIONS.....	86
TABLE 17: FREQUENCIES OF THE TECHNIQUES PER LAYER.....	87
TABLE 18: DIMENSIONS OF THE BLANKS.....	91

## **LIST OF ABBREVIATIONS**

kya- thousand years ago

LSA- Later Stone Age

MIS- Marine Isotope Stage

MSA- Middle Stone Age

mya- million years ago

NMMZ- National Museums and Monuments of Zimbabwe

OES- Ostrich Eggshell

PMG- Pomongwe

UNESCO-United Nations Educational, Scientific and Cultural Organization

ZMHS- Zimbabwe Museum of Human Sciences

# **CHAPTER ONE**

## **1. Introduction**

### **1.1. Background information**

The study sought to reconnoitre behavioural components of the hunter-gatherers during the late Pleistocene and Holocene at Pomongwe Cave (south-western Zimbabwe), as echoed by lithic technology. The late Pleistocene and Holocene epochs cover the period of the Middle Stone Age (MSA), and Later Stone Age (LSA), in southern Africa (Deacon & Deacon 1999). This study aims at clarifying the technological successions in the Zimbabwean Stone Age by taking an example of one specific raw material. The study follows previous research at PMG by C.K. Cooke (1963) and N.J. Walker (1995), which recognized high concentration of crystal quartz within the archaeological sequence at the site. The study takes a technological grounding and employs the *chaîne opératoire* approach (Leroi-Gourhan 1993; Driscoll 2010; Boëda 1995; Högberg & Larsson 2011; Lemonnier 1992; Schlanger 1994, 2005; Audouze 2002; Sørensen & Desrosiers 2008).

The study focuses on two main technological periods in Stone Age history, i.e. MSA and LSA periods. These periods are renowned for novelties that appear in the archaeological record during the inception of the MSA and through to the LSA. The emergence of the MSA by at least 300kya (Wadley 2015) corresponds with elements of behavioural traits which are evident in the archaeological record (See Table 1). These traits of Modern Human Behaviours (MHBs) did not appear as a full package at once but rather trickled in at different intervals, starting and stopping, or being absent in some regions of the subcontinent, hence the regional variabilities in these traits. As such, studies on the origin and development of MHBs have spawned debates amongst various scholars (Foley & Lahr 1997; Klein 2000; Deacon 2001; Henshilwood & Marean 2003). The current study however does not pander on these debates but rather focus

on one of the parameters to discuss MHBs, i.e. lithic technology. The study of lithic technology is indispensable in our understanding of the past as it provides information for traditions and behaviour at large. Lithic technology comprehends the study of raw material provisioning, knapping, and shaping.

<b>Trait(s)</b>
Burial of the dead as an indicator of ritual art
Sophisticated Hafting technology
Shell beads
Geometrically engraved ochre and ostrich eggshell (OES)
Worked bone
Ingenious lithic technology (including pressure flaking and heat treatment of rocks)
Manufacture of compound paint
Hunting techniques (including use of snares)
Familiarity with edible and medicinal plants
Manufacture of glue (mastic), from plants
Knowledge of woods to be burnt in hearths

**Table 1:** Traits used to identify Modern Human Behaviours (Modified after Henshilwood & Marean 2003; Wadley 2015).

The southern African MSA and LSA sequence can best be understood from a South Africa point of view, where most research in the sub-continent has been carried out over the past decades. The MSA was broadly a blade or flake production technology, with the products being produced mainly from prepared cores. This broad technological phase from South Africa can be categorised into 8 techno-complexes which have regional variants. Table 2 fully presents the MSA and LSA chrono-cultural framework, adopted from Lombard et al (2012), 'Updates on the sequence in South Africa and Lesotho.' The framework show that the Still Bay and Howiesons Poort techno-complexes have received a wide array of research and spread throughout the region. However this updated version (Lombard et al 2012) did not include the Pietersburg techno-complex, which is observed at various sites such as Cave of Hearths, Mwulu's Cave, Bushman Rock Shelter, Border Cave and Wonderwerk Cave (see Goodwin & van Riet Lowe 1929; Tobias 1949; Mason 1962; Plug 1981; McBrearty & Brooks 2000; Grün & Beaumont 2001; Beaumont & Vogel 2006; Porraz et al. 2015; Porraz et al 2018; de la Pena et al 2018).

The LSA on the other hand, though it has regional variations, appears in the sub-continent at least by <40kya (Lombard et al 2012). In terms of the lithic sequence the technology was basically a microlithic technology with the production of backed artefacts; evidence of hafted stone and bone tools; borers; bored stones; upper and lower grindstones; ostrich eggshell (OES) beads and other ornaments; bone tools (often with decoration); fishing equipment, and ceramics in the final phase. This phase is categorised by 6 techno-complexes (See Table 2).

Period	Techno-complex	Regional Variation	Age	Associated MISs	Characteristics	Site(s)
L.S.A <40 kya	Ceramic Final Later Stone Age	Ceramic post classic Wilton, Late Holocene with pottery	<2kya	MIS 1	*microlithic pieces; long end scrapers; ground stones; stone bowls; coarse ceramics; ochre; OES; metal objects; glass beads	Balerno Main Shelter; Biesje Poort 2; Blombos Cave; Boomplaas; Die Kelders; Jubilee Shelter; Kasteelberg; Rose Cottage Cave; Sehonghong; Wonderwerk Cave
	Final Later Stone Age	Post-classic Wilton, Holocene microlithic	~100-4kya	MIS 1	*macrolithic assemblages; large untrimmed flakes; sometime microlithic (scrapers, blades, bladelets, backed tools and adzes); ochre; OES	De Hoop; Elands Bay Cave; Nelson Bay Cave; Nkupe Shelter; Reception Shelter
	Wilton	Holocene microlithic	~4-~8kya	MIS 1	*developed microlithic tradition with numerous formal tools; standardised backed microliths and small convex scrapers; ochre; OES; bone, shell and wooden artifacts occur	Blombosfontein 3; Boomplaas; Elands Bay Cave; Jubilee Shelter; Kabeljous River Shelter; Matjies River; Rose Cottage
	Oakhurst	Terminal Pleistocene/ early Holocene non- microlithic	~7-~12kya	MIS 1	*flake-based industry; round, end and D- shaped scrapers and adzes; polished bone	Oakhurst; Boomplaas; Bushman Rock Shelter; Elands Bay Cave; Jubilee Shelter; Kruger Cave; Ntloana Tšoana; Rose Cottage Cave
	Robberg	Late Pleistocene microlithic	~12-~18kya	MIS 2	*systematic bladelet production (<26mm); few formal tools	Boomplaas; Elands Bay Cave; Nelson Bay Cave; Rose Cottage Cave; Sehonghong; Umhlatuzana

	Early Later Stone Age	Late Pleistocene microlithic	~8-~40kya	MIS 2-3	*unstandardized and often microlithic production; bipolar elements evident	Boomplaas; Border Cave; Elands Bay Cave; Heuningneskrans; Rose Cottage Cave; Sehonghong; Shongweni; Umhlatuzana
<b>M.S.A ~20-300kya</b>	Final MSA	MSA IV at Klasies River, MSA 4 generally	~20-40kya	MIS 3	*bifacial tools, bifacially retouched points; hollow-based points; bipolar technique evident; backed geometric shapes	Klein Kliphuis; Rose Cottage Cave; Sehonghong; Sibudu; Umhlatuzana
	Sibudu	late MSA/post-Howieson's Poort or MSA III at Klasies; MSA 3 generally	~45-58kya	MIS3	*points produced using Levallois technique; most retouch aimed at producing unifacial points; rarely bifacially retouched points	Border Cave; Diepkloof; Klasies River; Klein Kliphuis; Melikane; Ntloana Tsoana; Rose Cottage Cave; Sehonghong; Sibudu; Umhlatuzana
	Howiesons Poort		~58-66kya	MIS 3-4	*blade technology; small backed tools (segments, scrapers, trapezes, backed blades)	Boomplaas; Border Cave; Diepkloof; Klasies River; Klein Kliphuis; Klipdrift; Melikane; Ntloana Tsoana; Pinnacle Point; Rose Cottage Cave; Sibudu; Umhlatuzana
	Still Bay		~70-~77kya	MIS 4-5a	*thin (<10mm) bifacially worked foliate point; semi-circular or wide-angled pointed butts	Blombos Cave; Diepkloof; Hollow Rock Shelter; Peers Cave; Sibudu; Umhlatuzana
	pre-Stillbay		~72-~96kya	MIS 4-5		Blombos; Rose Cottage Cave; Sibudu, Diepkloof
	Mossel Bay	MSA II at Klasies River, MSA2 generally	~77-~105kya	MIA 5a-c	*recurrent unipolar Levallois points and blade production;	Klasies River; Melikane; Pinnacle Point

				formal tools infrequent; products have straight platforms	
Klasies River	MSA I at Klasies, MSA 2a generally	~105~130kya	MIS 5d-e	*recurrent blade and convergent flake production; end products are elongated and relatively thin; small platforms with diffused bulbs; denticulated pieces	Klasies River; Pinnacle Point; Ysterfontein
Early MSA		~130-300kya	MIS 6-8	*discoidal and Levallois flake technologies; blades produced from volumetric cores	Border Cave; Bundu Farm; Floorisbad; Kathu Pan; Lincoln Cave; Pinnacle Point; Wonderwerk Cave

**Table 2:** *Southern African MSA and LSA chrono-cultural framework (adopted from Lombard et al 2012; Wadley 2015).*

The current study looks at the MSA and LSA technologies, focusing on crystals quartz from PMG (See Figure 1). It examines the ways in which the material was exploited during the MSA and LSA techno-complexes at PMG. The material belongs to a set of raw materials that were used by hunter-gatherers during the Stone Age period, but differ from other materials exploited with regards to its physical and mechanical properties (Novikov & Radililovsky 1990; Petrin et al 2012; Petrovic et al 2015). It therefore provides an opportunity to see how people adapted to the specificities of crystal quartz.



**Figure 1:** *Example of crystal quartz pieces from different layers at Pomongwe layers. Picture modified after Cooke (1963).*

It is worth noting that this study was part of a broader project led by Dr C. Bourdier (University of Toulouse, France) and G. Porraz (CNRS, University of Paris Ouest, France), in collaboration with the University of Zimbabwe and the National Museums and Monuments of Zimbabwe. This project is called MATOBART and seeks to reinvestigate the Stone Age of the Matopos at large and to frame the chronology of its rock art, with PMG as the starting point. New excavations at the site commenced in November 2018 for a period of four weeks. The current study however did not include new data from the campaign because the campaign was delayed due to administrative issues and only happened during the course of writing of this dissertation. The lithic collections analysed for this research are from the previously excavated material by C.K Cooke, curated at the Zimbabwe Museum of Human Sciences in Harare (ZMHS).

## **1.2. Research Aims**

The goal of the study was to understand the exploitation of crystal quartz at PMG through a technological perception, during the MSA and LSA. It aimed at exploring the ways in which crystals were selected, knapped, shaped, retouched and discarded by hunter-gatherers. The study also explored how, and under which circumstances did the technology of crystal quartz change –or not- overtime.

## **1.3. Research Objectives**

- To study the forms and quantity of crystal quartz in the different layers and chrono-cultural phases.
- To evaluate how the *chaînes opératoire* of crystal quartz knapping varied in time throughout the MSA and LSA sequence at PMG.

## **1.4. Research Questions**

- i. The study questions the selection of crystal quartz as a raw material for lithic production. Crystal quartz is a mineral with a specific set of properties and the study intended to understand why it was selected?
- ii. Since crystal quartz has specific physical and mechanical properties, this mineral imposes constraints to the knapping that are different from other raw materials. The question to be addressed here is when hunter-gatherers started to select this mineral and how they adapted their technology.
- iii. The MSA and LSA are two periods of the Stone Age which can be technologically distinguished. This study asks what the transformation of crystal quartz will tell about the MSA and LSA inhabitants were they culturally and technologically similar or different in their exploitation of this material?

## **1.5. Rationale**

Technological studies focusing on knapping of crystal quartz are few in southern Africa and the world at large (Reher & Frison 1991; Kannegaard 2015; Pargeter and Hampson 2019).

First of all, there seems to be a general confusion in lithic technology on what crystal quartz is and how it differs from other rocks and other varieties of quartz. The nature of this material hinders most researchers from studying its exploitation in the production of lithic pieces (Reher & Frison 1991; de Lombera Hermida 2009). Crystal quartz has been found at many sites in southern Africa but has benefited of little attention. This study will therefore provide a bridge so that we'll have a better understanding of what crystal quartz is and also help understand the important of this material in lithic production.

This study assumed a technological perspective on the analysis of crystal quartz at PMG, also because of the previous Stone Age studies in Zimbabwe, which have been mainly classical typologies. As such, these studies have not yielded much in our understanding of the hunter-gatherers and their behaviours. Lithic technology on the crystal quartz will therefore provide significant information about hunter-gatherers and their way of life.

By studying the exploitation of crystal quartz at PMG overtime, the research will provide an alternative and complementary knowledge to what presently characterises the MSA and LSA technologies in southern Africa. The research will also further develop on the trends we observe within the MSA and LSA as well as between the MSA and LSA; and also better our understanding of MHBs in southern Africa.

## **1.6. Dissertation Outline**

The dissertation comprise of seven chapters. The first chapter was elaborated in the above sections.

-Chapter two will dwell on describing the research area in greater detail from the physiographic setting, climate, vegetation and fauna of the Matopos landscape, through to the Zimbabwean MSA and LSA sequence. The chapter will also concentrate on the archaeology of the Matopos, i.e. occurrence of the sites and their concentration and then lastly the archaeology of PMG.

-Literature review will be the focus of chapter three, which reviews literature on raw material studies; exploitation of crystal quartz on a worldview basis; and lastly the state of the art in southern Africa on crystal quartz

-Chapter four will deliberate on the material under study, i.e. the definitions, properties and morphology of the crystal quartz; it will also discuss the sample selection and problems encountered in the study; lastly this chapter will deliberate on the methods employed in the study, i.e. *chaîne opératoire*.

-Chapter five will focus on the presentation of the results from the analysis. The results will be presented through tables, graphs and figures.

-The discussion chapter will follow which will evaluate and synthesize the results from the previous chapter.

-The final chapter of the dissertation will be chapter seven, which will present the conclusion to the study as well as recommendations for future research on the topic.

## **CHAPTER TWO**

### **2. Research Area**

#### **2.1. Introduction**

PMG is found within the Matopos World Heritage Landscape and the landscape is a distinctive, hilly geographical unit some 25km south of Bulawayo in south-western Zimbabwe. The chapter presents a descriptive account of the physiographic setting of the Matopos World Heritage Landscape and positions PMG within this setting. It also gives an overview of the Stone Age of Zimbabwe focusing mainly on the MSA and LSA hunter-gatherers. The chapter goes on to discuss the occurrence and concentration of archaeological sites on the landscape and lastly position PMG within the Matopos and the broad Stone Age research in Zimbabwe and Southern Africa at large looking at the natural and archaeological archives of the site.

#### **2.2. Matopos Landscape**

Matopos is a UNESCO World Heritage Landscape, nominated in 2003. It lies 25km south of Zimbabwe's second capital city Bulawayo, in the south-central part of Matebeleland in western Zimbabwe. The landscape covers an area of approximately 2180 km<sup>2</sup>, of natural and archaeology surroundings. Large natural rock shelters are a major feature of the landscape, most of which are found under big boulders and some sculpted at the hill sides as a result of negative spheroidal exfoliation (Walker 1995). The landscape is made up of basement rocks such as schists and gneisses or older granites (Walker 1995); this is the pattern on most Zimbabwean Stone Age sites as they are mostly found as cave sites rather than open air sites.

### **2.2.1. Physiography**

The landscape is characterized by two main ecotypes viz. the flat, alluvial valleys cut by streams and the fairly steep-sided, rocky hills. The terrain of the landscape is such that there is a series of fairly small repeated hill-and valley portions (See Figure 2). The Matopos landscape is a granite pluton (MacGregor 1951) (See Figure 3), most of the rock types found in the area occur as intrusions within the granites (Smith 1968). Raw material which was used by Stone Age people, such as quartz and dolerite was quarried from within the landscape and other exotic stones like chalcedony and ochre were imported from the basement of the landscape (Walker 1995).



**Figure 2:** *Physiographic setting of the Matopos Picture by J. Matembo.*

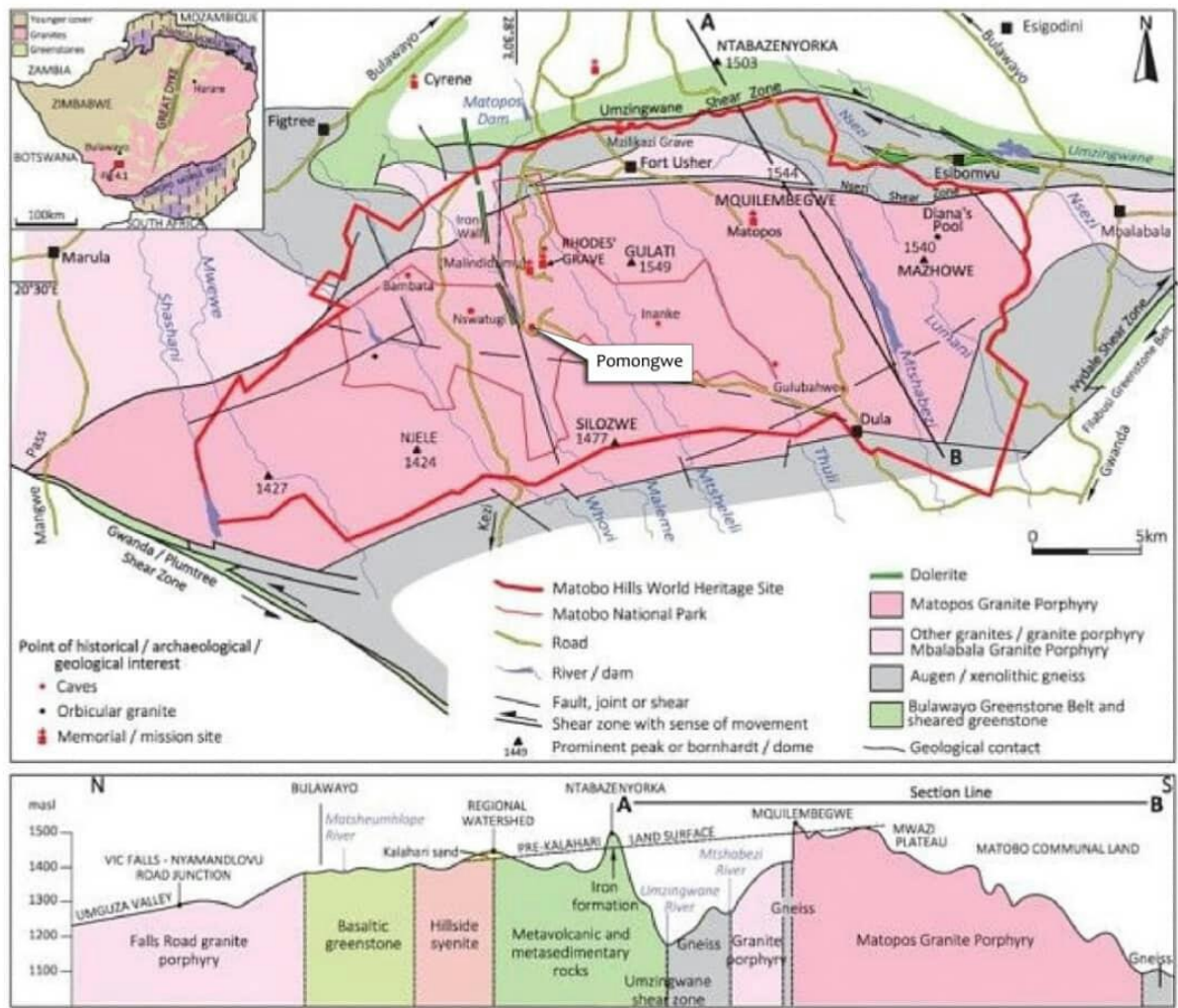

**Figure 3:** Geological map of the Matopos World Heritage Landscape, showing archaeological sites and the variable topography. (After Hubbard 2018)

### 2.2.2. Climate

The Matopos generally characterised by temperate climatic conditions. The summer season in the landscape normally begins in mid-November and warm and humid, this is followed by the autumn which is characterized by warm and dry atmosphere from late March to early May. The cold winter season follows with extreme cold nights and then lastly spring from mid-September. Temperatures are usually throughout the year in the Lowveld (Walker 1995). The landscape receives an irregular rainfall in the summers which is complemented by light non-seasonal drizzle (Walker 1995).

### **2.2.3. Vegetation**

The combination of the climatic and topographic conditions of the Matopos results in the wide array of fauna and flora which characterise the landscape, (Walker 1995). The vegetation is a diverse woodland interspersed with grassland and savannah woodland. It is typical of the Zimbabwean Highveld vegetation. Ingram (1960) note that the Matopos is a *Terminalia-Hyparrhenia* veld. Trees such as *Terminalia sericea* (mususu), *Colophospermummopane* (mupane), *Brachystegiaspiciformis* (musasa), *Brachystegiatamarindoides* (muunze) are the most dominate in the area with other fruit tress such as *Sclerocaryabirrea* (marula) and *Ficuscapensis* (figs) also present (Walker 1995).

### **2.2.4. Fauna**

There is faunal diversity in the landscape, which is distinctive to that of the African savannah woodland characterized by smaller animal species (Walker 1995). Faunal types found in the landscape include *Pedetes capensis* (spring hare), *Paraxerus cepapi* (squirrel), *Procavia capensis* (dassies), *Gonimbrasiabelina* („mopane worm“), *Apis mellifera* (honey bee), *Acrida bicolor* (grasshopper) and *Pyxicephalus adspersus* (bull frog). Large game is also dominate in the landscape such as *Syncerus caffer* (buffalo), *Loxodonta africana* (elephant), *Diceros bicornis* (black rhino), *Equus burchelli* (zebra), *Hippotragus niger* (sable), *Oreotragus oreotragus* (klipspringer) *taurotragus oryx* (eland), *taurotragus strepsiceros* (kudu) and *potamochoerus porcus* (bush pig).

## **2.3. Zimbabwean Stone Age sequence**

The fulcrum of this research focuses on the MSA and LSA of Zimbabwe. Stone Age symbolizes the first and longest period of human technology, when hunter-gatherers mainly used stone as their raw material for tool production, beginning some 3.3 million years ago (mya) (Deacon & Deacon 1999; Harmand et al 2015). The period is generally divided into three phases on technological basis; Early Stone Age (ESA) (~3mya- ~300kya}, Middle Stone Age

(MSA) (<300kya- ~>30kya) and lastly Later Stone Age (LSA) {~<40kya to the recent ethnographic present} (Walker & Thorp 1997; Lombard et al 2012; Wadley 2015).

Stone Age research in Zimbabwe commenced at the turn of the 20th century. Geologists, surveyors, clergymen and prospectors during their exploration of the country started to recognise stone tools and documenting archaeological sites (Walker 1995; Walker & Thorp 1997; Marufu 2012). However, research on the Stone Age in Zimbabwe has taken second place to that of prehistoric Farming Communities.

Stone Age research in the country was inspired by the excavations of Arnold and Jones at Bambata Cave in 1919. Walker (1995) note that, these excavations marked the birth of well documented field campaigns in the region. Researches continued but mainly focusing on the LSA and within the western parts of Zimbabwe where most industries were named after type sites (See Figure 4). A comparison was carried out between the Zimbabwean MSA and LSA sequence and that of southern Africa so as to better position our sequence in a broader southern African realm (See Table 3 below).



**Figure 4:** Map showing Stone Age sites in Zimbabwe mentioned in this manuscript.

According to Walker and Thorp (1997) the MSA sequence in Zimbabwe is divided into two main stages:

- a) The Bambata (alternatively called Stillbay)

The Bambata techno-complex was originally described from the type site Bambata Cave in the Matopos (Armstrong 1931). The assemblages of this techno-complex was also described at Nswatugi (Jones 1933), Khami, Pomongwe, Redcliff and Zombepata (Cooke 1957; 1963; 1971). This techno-complex is characterized by bifacial and unifacial points, scrapers, backed blades and large elements (Walker & Thorp 1997), and because of these characteristics it was equated to the Still Bay complex in South Africa. The actual dating of this phase is not clear.

It is presumably dated between MIS 5 or/ 4 (Walker & Thorp 1997, Porraz 2017 pers. comm.) and is followed by the late MSA (The Magosian/Tshangula) in Zimbabwe

b) Late MSA (alternatively called Magosian or Tshangula in the literature)

Walker & Thorp (1997), note that Bambata is followed by the Late MSA (Magosian) phase, (Cooke 1969). This techno-complex was described also at Khami, Pomongwe and Tshangula (Cooke 1957, 1963, 1969). It is characterized by bladelet cores, segments and scrapers as well as bone artifacts and ostrich eggshell beads (Walker 1995). The techno-complex is dated from 35kya- 20kya, associated with MIS 3 (Walker & Thorp 1997). It corresponds with the Final MSA, MSA IV at Klasies or MSA 4 generally in southern Africa. This techno-complex marks the end of the MSA in Zimbabwe and at times is found mixed with the Terminal Pleistocene microlithic techno-complex artifacts, which is the first industry of the LSA.

The LSA in Zimbabwe is the better understood period as it has received more attention. This period is divided into six techno-complexes that are:

a) Terminal Pleistocene microlithic techno-complex

This technological phase represent a mix of material dated between 30 000 to 13 000 BP (Walker & Thorp 1997). It is characterized by small blade tools (bladelets) and bladelet cores (Walker & Thorp 1997). This techno-complex is however absent from the Matopos archaeological complex. This techno-complex corresponds with the Early LSA in South Africa, which is associated with the MIS 3-2.

b) The Maleme

The Maleme techno-complex is the first definite LSA techno-complex in Zimbabwe, it was named after the Maleme River, located in the Matopos. It was described at Pomongwe Cave and Cave of Bees. The techno-complex is dated 13 000-11 000 uncal. BP, (Walker & Thorp

1997). Maleme is characterized by microlithic scrapers with straight or irregular edges. A few microlithic prepared cores and triangular points are also present. The first appearance of bone points, awls, needles and cylinder beads occur in this period. The Maleme techno-complex corresponds to what was happening in southern Africa, with the Robberg techno-complex and is associated to MIS 2.

#### c) The Pomongwe

This techno-complex is named after the type site, Pomongwe cave. It was also described at other sites such as Nswatugi and Cave of Bees. The techno-complex is dated from 11 000-9 400 uncal. BP. Pomongwe is characterized by large circular or convex scrapers, however recent research studies have shown that there is variation in size and smaller scrapers are also available, bone matting needles and tortoise shell bowls are also present (Cooke 1963, Walker 1995, Walker & Thorp 1997). This techno-complex tally with the Oakhurst in South Africa, it is associated with MIS 1.

#### d) The Nswatugi

This techno-complex was first recognized by Van Riet Lowe at Hillside in Bulawayo and he used the term Wilton for it. It is one of the best known LSA industries in Zimbabwe (Walker & Thorp 1997). The Nswatugi techno-complex has been given different nomenclature in different parts of the country ranging from Neolithic, Bushman or Pygmy (Gardner 1928); Wilton and Rhodesian Wilton (Jones 1933; Robinson 1958) in Nyanga; Matopan for the Matebeleland variant, Pfupi in Mashonaland, Khami (Simons 1968) and Nswatugi (Walker & Thorp 1997). The techno-complex is dated from 9 400- 4 800 uncal. BP. It is characterized with the propagation of backed geometrics, segments, thumbnail scrapers and other organic tools present in preceding phases (Walker 1995, Walker & Thorp 1997). The dates and

characteristics of this techno-complex; tally well with the Wilton/ Holocene microlithic in southern Africa. It is associated with MIS 1.

e) The Amadzimba

The techno-complex was first observed by Cooke & Robinson (1954); it is named after the Amadzimba Cave in Matopos. It has been described at Pomongwe and Bambata caves, and the excavators were pleased by the propagation of organic material such as bone tools, shale pendants, ostrich egg shell canteen with neatly bored apertures, bone link-shafts, bone point and drilled bone disc beads (Cooke & Robinson 1954; Walker & Thorp 1997; Chiwara-Maenzanise 2018). The techno-complex is dated between 4 800-*c.*2 200 uncal. BP. and corresponds with the Final LSA in South Africa. It is associated with the MIS 1.

f) Ceramic LSA

This techno-complex is characterized by the appearance of pottery within the LSA at Bambata Cave in the Matopos (Schofield 1940). This enticed attention to the prospect of early ceramic and stone working techno-complex. Walker & Thorp (1997) are of the idea that the knapper and the potter were related since there is evidence of continuity in stone tool production from the preceding LSA assemblages. The techno-complex has also been given various names depending with the region it has been found. In western Zimbabwe, it has been termed Ceramic Wilton/Matopan (Cooke et al 1966). This techno-complex is dated post 2 000 uncal. BP. (Walker & Thorp 1997). It tallies with the Ceramic final LSA in South Africa and associates with the MIS 1.

<b>Period</b>	<b>Zimbabwean Techno-complex</b>	<b>Zimbabwean Variant</b>	<b>South African Variant</b>	<b>Zimbabwean Age</b>	<b>South African Age</b>	<b>Associated MIS</b>
<b>LSA &lt;40kya</b>	The Ceramic Later Stone Age	Ceramic Wilton; Matopan	Ceramic Final Later Stone Age	2kya BP uncal.	<2kya	MIS 1
	The Amadzimba	--	Final Later Stone Age; post-classic Wilton; Holocene microlithic	2.2kay-4.8kya BP uncal.	~100-4kya	MIS 1
	The Nswatugi	Wilton; Pfupi	Wilton; Holocene microlithic	4.8-9.4kya uncal.	~4-~8kya	MIS 1
	The Pomongwe	--	Oakhurst	9.4- 11kya	~7-~12kya	MIS 1
	The Maleme	--	Robberg; Late Pleistocene microlithic	11- 13kya	~12-~18kya	MIS 2
	The Terminal Pleistocene Microlithic	--	Early Later Stone Age; Late Pleistocene microlithic	13- 30kya	~18-~40kya	MIS 2-3
<b>MSA</b>	The Late Middle Stone Age	Magosian; Tshangula	Final MSA; MSA IV at Klasies; MSA 4 generally	20-35kya	~20-40kya	MIS 3
	The Bambata	Stillbay	--	--	--	MIS 4or 5

**Table 3:** Zimbabwean MSA and LSA sequence in correspondence to Southern Africa (following Walker and Thorpe 1997, Lombard et al. 2012)

## **2.4. Archaeology of the Matopos**

Since the inception of Stone Age research in Zimbabwe in the 20th century, Matopos has been the main reference centre of study. The landscape has an abundance of painted rock shelters many with archaeological deposits (Walker 1980; 1995). Most research on the Zimbabwean Stone Age sequence has been conducted within this landscape; it is indisputably an archaeologically significant landscape, with long occupational sequences in the country and the southern African region at large. The deposits from the landscape assumedly dated back from as early as the Middle Pleistocene (700 000-125 000BP) with human occupation lasting until present (Walker 1995). Excavated sites within the landscape such as Bambata (Armstrong 1931), Nswatugi (Jones 1933), Tshangula (Cooke 1963), Pomongwe (Cooke 1963), and Kalanyoni (Walker 1980) have provided the general outline of the Zimbabwean Stone Age cultural sequence (Walker 1980).

## **2.5 Pomongwe Cave**

The research focuses on one of the main sites within the Matopos which is Pomongwe Cave. The cave is apsidal in form, typical of granitic areas, as it is formed as a result of negative exfoliation (Cooke 1963; Walker 1995) (See Figure 5). It lies at the end of a small valley with its aperture facing the north-eastern direction. According to Walker (1995: 127), the cave “is about 20m long and 20m wide at the drip-line, and the ceiling is about 15m above bedrock (Cooke 1963, pp.77-8).” This site is of significance as it has a long sequence with both MSA and LSA deposits, assumedly dating back to the Middle Pleistocene (Cooke 1963; Walker 1980; Walker & Thorp 1997).



**Figure 5:** *Pomongwe Cave picture by G. Porraz*

### **2.5.1. The Archaeology of Pomongwe**

PMG was first excavated by C.K Cooke from the 3rd of June 1960 to the 20th of April 1961 (Cooke 1963). He sunk three trenches in the cave, i.e. I-III (Figure 6 below) and exposed a long well stratified sequence of *ca.* 4m with MSA and LSA occupations (with mineral and organic preservation throughout the sequence). The excavations were conducted in a well-organized manner. Initially, Cooke and his team decided to excavate the deposits in spits of 2-3 inches but soon realized that it was not correct to excavate in that way owing to the slope of the deposits. They then decided to follow each colour and texture of soil, so as to distinguish between different layers. The sediments from the excavation were sieved (the size of the mesh is not provided) and they collected all the artifacts including the organic material such as bones and seeds (Cooke 1963). Cooke noticed a spall layer separating the MSA and LSA sequences, which was suggestive of a period of non-occupation of the site (Cooke 1963).

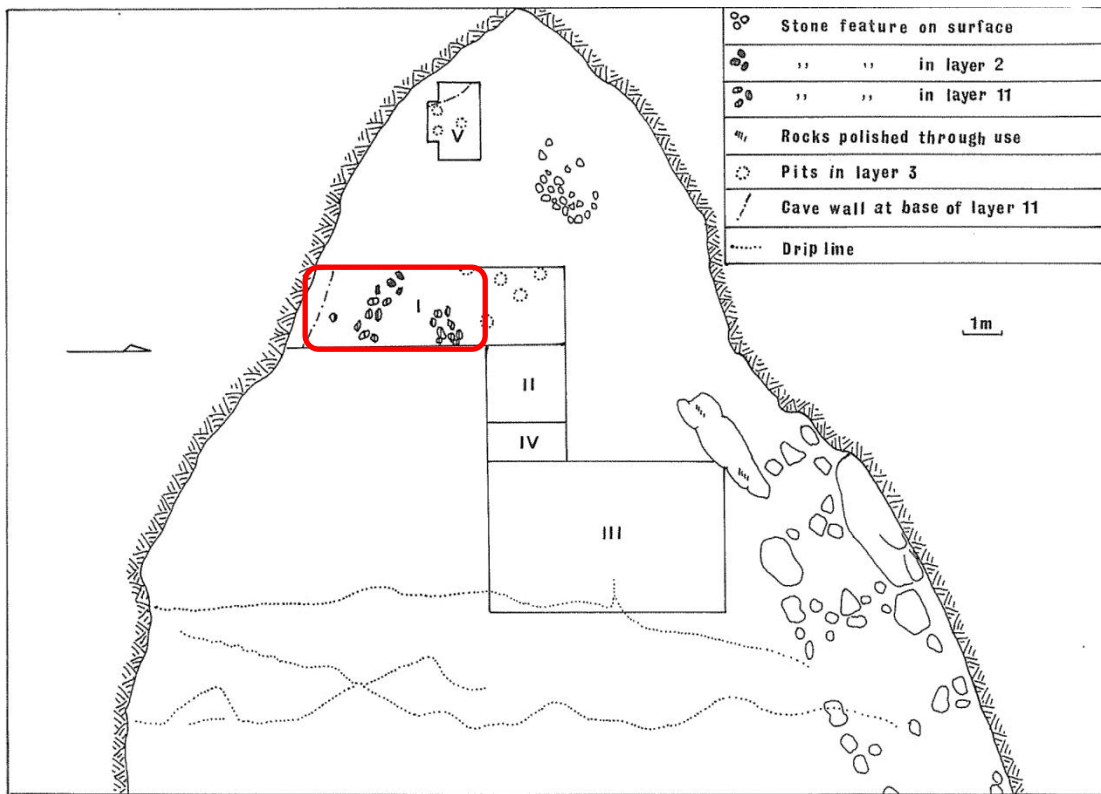

Fig. 62. Pomongwe Cave: plan.

**Figure 6:** *Planimetry of Pomongwe, showing the five trenches sunk at the site (Trench I to III are Cooke’s excavations, Trench IV and V are Walker’s excavations). The area encircled in red is the location of the area under study (After Walker 1995).*

After Cooke's work at PMG in 1961, N.J Walker re-opened the site in 1979 (Walker 1980; 1995) and excavated two new trenches (Figure 6 above). His excavations were interested in the LSA occupations and he exposed a sequence of 1.4m. Walker sieved all the sediments in 2 and 3mm sieves, which enabled the collection of all fragments and recorded all the information about the stratigraphy and profiles (Walker 1995). The stratigraphy also had well preserved organic remains throughout the LSA sequence.

For the area under study, Cooke exposed a well stratified deposit (See Figure 7 and Table 4).

Level 1 constituted of the surface dust which was a very fine greyish ash with very little cultural material. This was followed by a sterile, compacted red-brown layer, which was introduced into the site by the curator in the 1920s. These two levels were not included in this study as they were considered disturbed and out of context

Level 3 comprised of flocculent grey ash, and it had large chunks of manure in it.

Level 4 was a whitish ash, which its remnants might have been mixed with the manure to form the grey ash of level 3.

Levels 5, 6 and 7 comprised of burnt Marula kernels and ash, and as such the deposit in these levels had variability in colour.

Underneath was a white ashy hard-beaten floor with very little charcoals, this was considered to be levels 8 and 9.

From levels 10-12, the deposit was homogenously black ash comprising of bone, with some charcoals and a bit decomposed granite but no spalls. There was a very explicit dissection which occurs in the deposit at the base of level 12. The whole area is reported to have been covered with flat large granite spalls; this is believed to have been the hiatus between the MSA and LSA at PMG, when the site was not occupied.

From layer 13 downwards, the deposit is homogenous despite the variability in the colour of the ashes and a reduction in the amount of spalls.

Towards the base of level 22, there is an increase in the granitic sands and reduced ash quantities. The sizes and quantities of charcoals also become very meagre at these levels.

Another geological or climatic change is witnessed at the base of level 23. The deposit is yellow in colour and is almost pure granitic sands, ashes have disappeared.

The deposit remains like this till the bottom of level 27A; here the deposit comprise mainly of decomposed granitic sands till bedrock at *ca.* 4m (Cooke 1963).

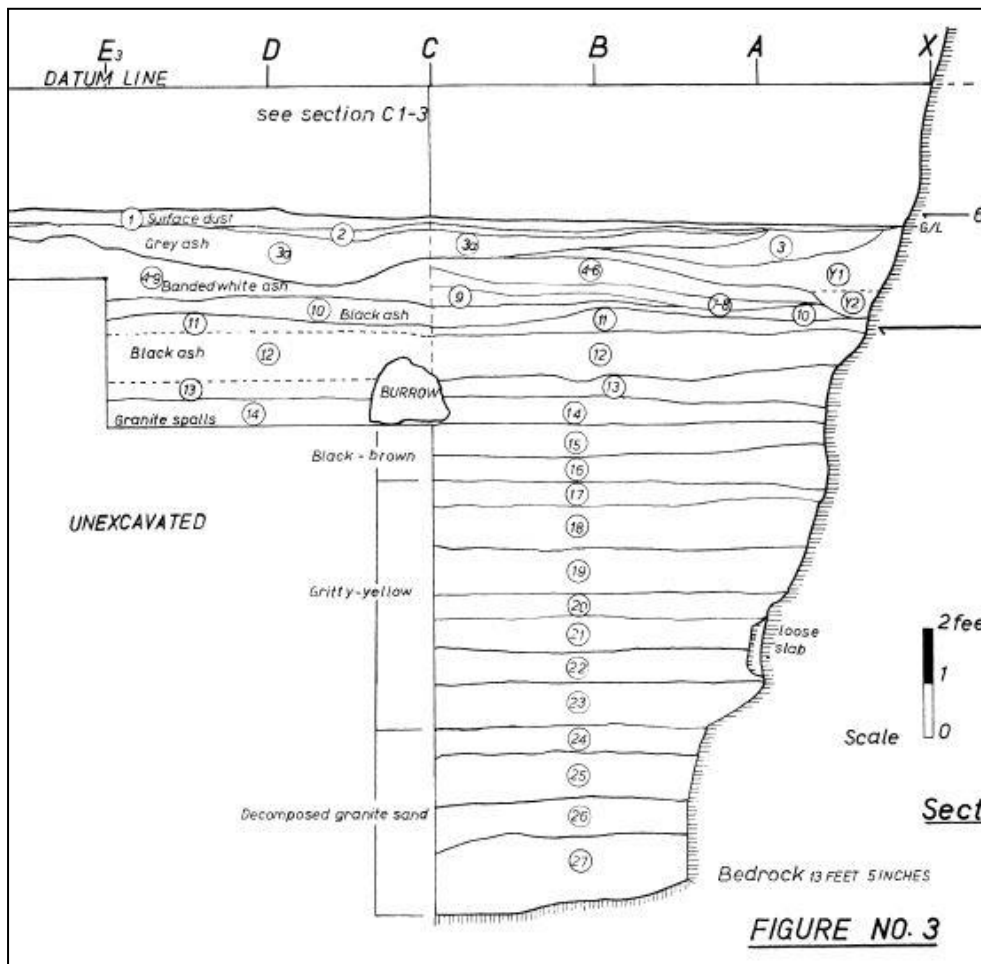

**Figure 7:** Stratigraphic profile from trench I of Cooke, showing the Eastern section of the trench. Number of layers are encircled in black (After Cooke 1963).

Period	Techno-complex	Level	Context
LSA	--	1	Surface Dust
LSA	--	2	Surface Dust
LSA	The Amadzimba	3	Grey Ash
LSA	The Nswatugi	4	Banded White Ash
LSA	The Nswatugi	5	Banded White Ash
LSA	The Nswatugi	6	Banded White Ash
LSA	--	7	Banded White Ash
LSA	The Pomongwe	8	Banded White Ash
LSA	The Pomongwe	9	Banded White Ash
LSA	The Maleme	10	Black Ash
LSA	The Maleme	11	Black Ash
LSA	The Maleme	12	Black Ash
MSA	The Bambata	13	Black Ash
MSA	The Bambata	14	Black-Brown
MSA	The Bambata	15	Black-Brown
MSA	The Bambata	16	Black-Brown
MSA	The Bambata	17	Gritty-Yellow
MSA	The Bambata	18	Gritty-Yellow
MSA	The Bambata	19	Gritty-Yellow
MSA	The Bambata	20	Gritty-Yellow
MSA	The Bambata	21	Gritty-Yellow
MSA	The Bembesi	22	Gritty-Yellow
MSA	The Bembesi	23	Gritty-Yellow
MSA	The Bembesi	24	Decomposed Granite Sands
MSA	The Bembesi	25	Decomposed Granite Sands
MSA	The Bembesi	26	Decomposed Granite Sands
MSA	The Bembesi	27	Decomposed Granite Sands

**Table 4:** Trench I stratigraphy. NB: Highlighted layers had no crystals recovered and layers 1 & 2 were not included in this study.

The present study focuses on Cooke's work as it exposed the whole Stone Age sequence at PMG, which collaborates with the objectives of the study to examine the exploitation of crystal quartz at the site through time. Cooke (1963) from his excavations initially established five industrial phases namely: Bembesi (Proto-Stillbay), Bambata (Stillbay), Magosian (Tshangula), Pomongwe (Large scrapers) and lastly Nswatugi (Wilton). However, following updates from Walker (1995); the sequence of PMG is divided into six chrono-cultural phases as Walker additionally recognized the Amadzimba.

The chrono-cultural phases at PMG can be subdivided as follows:

-The **Bembesi**: This techno-complex covers the area from the bedrock (27A) to layer 22. According to Cooke, the techno-complex in this phase is similar throughout the sequence, and it does not show any signs of major change. Technologically, the techno-complex was oriented towards the production of flakes and the manufacture of macro-tools and scrapers (Cooke 1963). During this phase vein quartz was the main raw material used. Following Cooke (1963), the first appearance of crystal quartz at the site is during this phase in layer 22, in the form of a burin like-tool. These occupations are not dated but are expected to predate MIS5 (Walker & Thorp 1997; Porraz 2018 pers. comm.).

-The **Bambata**: The techno-complex is from layers 21-13. The deposit of this sequence was homogenous, though there is variation in terms of density. There is an increase in the number of granite spalls throughout this phase, but more prominent in the layer 13 (Cooke 1963). The technology is oriented towards the production of flakes and blades and includes the presence of a few bifacial pieces. Vein quartz was also the most common raw material, with agate, chalcedony and quartzite also appearing as imported materials (Cooke 1963). The exploitation of crystal quartz is also evident in this chrono-cultural phase. There are no dates yet for these occupations, but they are expected to belong to the MIS5 or 4 (Walker & Thorp 1997; Porraz 2018 pers. comm.).

-The **Maleme**: Once regarded as the transitional phase between MSA and LSA (Cooke 1963), this techno-complex followed from layers 12-10. This phase is constituted in homogenous sediment. The technology focused on the production of microlithic elements such as bladelet cores, segments and scrapers and includes the exploitation of crystal quartz. Other raw materials such as chalcedony, agate, quartzite and silcrete were also exploited in the production of lithic tools. The occupation of this phase is radiocarbon dated (samples from Walker's excavation), between c. 13 100- 11 000 uncal. BP (Walker & Thorp, 1997).

-The **Pomongwe**: This phase covers layers 9-7 and comprises of homogenous consolidated white ashes. The set of tools produced in this phase are not similar to the preceding Maleme, nor are they parallel to the LSA Wilton (Cooke 1963). The technology is oriented towards the manufacture of large circular scrapers or convex scrapers (Walker and Thorp 1997). The cores are essentially absent from this techno-complex. The main raw material for the production of these large scrapers is chalcedony. The exploitation of crystal quartz as a raw material in this phase is limited as compared to the other phases (Cooke 1963). These occupations are dated (samples from Walker's excavation) between *ca.* 11 000- 9400 uncal. BP (Walker & Thorp 1997).

-The **Nswatugi**: This techno-complex spans from layer 6-4. The sequence comprise of very soft ashy layers which at times is mixed with burnt Marulas and charcoal. The technology of this phase focuses on the production of microliths, mainly the backed geometric, crescent and segments, bladelets and small convex scrapers. Various raw materials were used during the production of the lithic types during this phase. Crystal quartz constitutes a high percentage in terms of exploitation for the production of the lithics. This phase is dated (samples from Walker's excavation) around *ca.* 9400- 4800 uncal. BP (Walker & Thorp 1997).

-The **Amadzimba**: The techno-complex covers layer 3 and comprises of white ash in layer 2 and brown ash in layer 3. It is characterized with the proliferation of bone tool technology evidenced with the appearance of bone link shafts, numerous bone arrows points, drilled bone disc beads, bone cylinder beads, shell pendants tortoise shell bowls, ostrich egg shell canteens and neatly bored apertures. In terms of lithic, the technology is oriented to the production of backed geometrics (Chiwara-Maenzanise 2018). The phase is dated (following Walker's excavation) from 4 800-c.2 200 uncal. BP (Walker & Thorp 1997).

It is worth noting that the industries evident at PMG are also found in the other Matopos sites as well as in other areas of Zimbabwe where excavations have been conducted, such as Redcliff Cave (Brain & Cooke 1967) and Zombepata (Cooke 1971).

## **CHAPTER THREE**

### **3. Literature Review**

#### **3.1. Introduction**

The chapter provides a review on the literature that is the background of this current study. The review will position this study in a broader spectrum with what is already known in Stone Age studies on crystal quartz from a worldview perspective and also in the southern African region. The chapter also highlight on the methodological conceptions employed in this study.

#### **3.2. Quartz Raw Material Studies**

Quartz consists of almost 100% Silicon dioxide (SiO<sub>2</sub>) and it is one of the most frequent minerals on the earth's surface and an important component of many igneous, sedimentary and metamorphic rocks (granite, sandstones, quartzite) (de Lombera Hermida 2009; Driscoll 2010). The material is a hard and brittle mineral, which makes it suitable for stone tool knapping and use. Quartz is generally subdivided into two forms which are cryptocrystalline (microcrystalline) and macrocrystalline. The cryptocrystalline forms include chalcedony, agate, flint, chert and jasper (just to mention a few) and these fell beyond the scope of this study. Macrocrystalline forms include vein quartz (milky quartz and its other variants) and rock crystals (Anon 2009), these are generally referred to as rocks but in fact they are minerals. The macrocrystalline quartz forms mainly in three geological environments, i.e. i) silica-rich molten rock during cooling and solidification; ii) in pegmatites during and following pneumatolytic processes and iii) mostly in watery solutions of silica. This form of quartz forms through the cooling of hydrothermal solutions or molten rocks; and the formation determines whether they form as automorphic or xenomorphic quartz, (de Lombera Hermida 2009; Driscoll 2010). Automorphic quartz, which is the main focus of this study, forms with clear recognisable crystal shape, traditionally they are referred to as hyaline or translucent quartz (de Lombera

Hermida 2009). The xenomorphic variant implies that during the formation process, the quartz crystals do not form properly and they form through the combination of several micro-crystals (de Lombera Hermida 2009). It is one of the main raw materials which were exploited by prehistoric communities in the production of lithics, and is found in many areas of the world (Reher & Frison 1991; de Lombera Hermida 2009; Driscoll 2010).

Bisson (1990) notes that quartz is the most common mineral occurring in Africa that was exploited in prehistory, its use however by hunter-gatherers was variable across time and space (Pargeter & Hampson 2019). However, very few reports differentiate between vein and crystal quartz and as such are lumped together.

Crystal quartz however, due to their distinctive morphology and flaking properties requires distinct treatment when knapping. Crystal quartz appears in the rhombohedral shape varying sizes, from very tiny prisms to crystals which can grow up to 0.5-0.6m (Anthony et al 2001; Novikov & Radililovsky 1990). This form gave the exploiters small surfaces to strike the blanks, this morphology also allows the material to break along external cleavage planes. The material is also relatively brittle and demonstrates properties of conchoidal fracturing (Pargeter & Hampson 2019). Reher & Frison (1991:393) refer to crystal quartz knapping as “a study in contradiction, since one flake can come off as though from the finest obsidian while the next suddenly turns into so much crystal dust in a knapper’s hand”. The hunter-gatherers however exploited this material regardless of these properties and they benefitted products with sharp edges.

### **3.3. Crystal Quartz Exploitation: Worldview**

Crystal quartz has been recorded from a number of archaeological sites in all continents (Reher & Frison 1991). It should be noted here that the exploitation of this material in prehistory has been more commonly examined in Europe, Asia and the Americas as compared to Africa (Pargeter & Hampson 2019). The following reviewed literature will therefore provide an account from beyond the region and then position the current study with what has been done and is known in the southern African region. The review will sum up two lines of evidence: provenance characterisation and technological descriptions on a worldview scale.

The occurrence of quartz crystal has been observed in archaeological assemblages from the high Arctic to South America (Reher & Frison 1991). Different groups and cultures world over associate crystal quartz with spiritual, healing and religious behaviours, they believe that this material holds super natural powers from the outside world (DuBois 2009; Eliade 1972). Crystal quartz is also usually found in caves and mountain ranges which are mainly associated with sacredness and spiritual powers. But such spiritual or ceremonial values have obviously very limited visibility in the archaeological record.

Crystal quartz has been extensively used for the production of various lithic tool types. Binford (1983) presented an informative account of the use of crystal quartz by the Nunamiut Eskimo of Anaktavak. The study focused on the procurement and use of crystal quartz as a tool stone in prehistory.

Another important reference is the study of Reher & Frison (1991) that analysed the use of crystal quartz as a raw material within the Wyoming region and compared the crystal quartz technology that was used in three different sites from the Paleoindian to the Protohistoric period. From their analysis, they noticed that the production of chisel-like implements based on whole crystal, and reduction of other whole crystals of higher quality into sharp blades were the main patterns. At the Fenn Clovis Cache, three points of crystal quartz were recovered.

Reher & Frison (1991: 388) note that, “it was clear that the Fenn Cache knapper (or knappers) had to adapt to the properties of crystal, and that many difficulties were being encountered.” The assemblage indicated that the knappers had to adapt to the properties of the crystal quartz, since many difficulties were encountered during the production of the lithic tools from the material. This research by Reher & Frison (1991) showed that crystal quartz was an important raw material in the economic systems of prehistoric people.

Several other researchers have been conducted to analyse the exploitation of crystal quartz as a raw material for tool production in prehistoric economies. Nami (2009) studied how this material was used in the production of ‘fishtail projectile points’ by the Paleo-South Americans. Petrovic et al (2015) also analysed the origin, production and use of crystal quartz in the Neolithic of Serbia. The production of crystal quartz at Vinca-Belo Brdo followed series of “chaîne opératoire from the extraction of the crystals, the breaking and cracking and finally the knapping of the pieces.” Their research focused on defining the origin of crystal quartz which was found at the site of Grivac, through the analysis of inclusions and also to understand the chaîne opératoire of crystal quartz pieces. They analysed the characteristics of crystal quartz through petrographic thin sections in order to understand the provenance of the material and to infer on issues to do with exchange of raw materials by the Neolithic societies.

Kannegaard (2015) in her analysis of the function of micro blades from The Salish Sea Region of Washington State during the late Holocene (Locarno Beach Phase), contributed to the study of the use of crystal quartz as a raw material for lithic production. The research concluded that the crystal quartz micro blades were multiuse tools; they were used to process varies materials and were hafted in different fashion. There is also a possibility that that these tools were functional in other ceremonial events.

Another research that focuses on the technological exploitation of crystal quartz as a material for tool production was by Morgado et al (2016), in the Copper Age of southern Iberia in Spain.

They analysed the procedures and techniques which were used in tool production as well as the provenance of the raw material. They concluded that the exploitation of crystal quartz was an adaptation to the socio-cultural setting of southern Iberia, with a vibrant blade technology and bifacial reduction.

### **3.4. Lithic Technology and crystal quartz: A State of the Art in Southern Africa**

Crystal quartz has been discovered and mentioned at a number of Stone Age sites in southern Africa, though it is important to recall that researchers often describes and associates transparent quartz with crystal quartz (which is not necessarily the case). The first recorded appearance of crystals quartz in southern Africa is during the ESA-MSA transition at Wonderwerk Cave (Beaumont & Vogel 2006). The material has since then been recorded from a number of MSA and LSA sites during the Still Bay, Howiesons Poort, Wilton, Oakhurst, Ceramic final LSA just to mention a few (Binneman 1997; Delagnes et al 2006; de la Pena & Wadley 2014; Rots et al 2017) (See Table 5). However, very few studies have focused on this material. Crystal quartz has been mentioned at sites like Jubilee Shelter (Wadley 1987; Barham 1992) where they argue that the exploitation of this material was somewhat symbolic. The same view is echoed by Wurz (1999) at Klasies River. Crystal quartz was also observed at other sites in South Africa such as Rose Cottage (Clark 1997); Pinnacle Point (Bird et al 2007); Elands Bay Cave (Orton 2006); Border Cave (Villa et al 2012); Wonderwerk (Beaumont and Vogel 2006); Boomplaas (Pargeter et al 2018) and Sibudu Cave (Wadley 2008; de la Pena & Wadley 2014; de la Pena et al 2018) where Howiesons Poort crystal quartz backed tools have been analysed (Delagnes et al 2006; de la Pena & Wadley 2014; de la Pena et al 2018).

Crystal quartz has also been mentioned at sites in Botswana such as Manyana Rock Painting (Robbins 1985); Mahopa (Yellen & Brooks 1989) and AK2006/001 G (Orton 2008).

Research by Mitchell & Steinberg (1992); Mitchell (1995) at Ntloana Tšoana and Sehonghong respectively was followed up by recent research on the same sites by Pargeter & Hampson

(2019). They later explored the materiality of quartz from an interpretive and technological perspective. They surveyed the ethno-historic and contemporary archaeological literature on the properties, qualities, use and analysis of crystal quartz and then considered the two sites which had undocumented trends in the exploitation of crystal quartz during the Terminal Pleistocene in Lesotho. They observed that there was a brief but conspicuous increase in the use of crystal quartz after c.14 ka cal BP at Sehonghong and Ntloana Tšoana. Thompson et al (2012) also observed crystal quartz at the Airport Site in Malawi; this is a MSA, HP site dating approximately between 58-66kya. The limited literature on crystal quartz technology in southern Africa shows that the mineral has not attained much attention as other raw materials amongst researchers in the region or the properties of the mineral has hindered research hence lumping it together with the other varieties of quartz.

Period	Techno-complex	Age	Associated MIS	Site(s)	Reference(s)
LSA <40kya	Ceramic Final LSA	<2kya	MIS 1	Doornfontein	Beaumont & Boshier 1974
				Elands Bay Cave	Orton 2006
				Luano Rock Shelter	Bisson 1990
				Mahopa (M1)	Yellen & Brooks 1989
				Manyana Rock Painting site	Robbins 1985
	Final LSA	~100- 4kya	MIS 1	Rockshelter 2	Robbins 1985
				Rockshelter 3	Robbins 1985
	Wilton	~4- ~8kya	MIS 1	Dunefield	Orton 2008
				Midden 1	
				Jakkalsberg L	Orton & Halkett 2010
Oakhurst	~7- ~12kya	MIS 1	Jubilee Shelter	Wadley 1987; Barham 1992	
			The Havens Cave	Binneman 1997	
Robberg	~12- ~18kya	MIS 2	Ntloana Tšoana	Pargeter & Hampson 2019	
MSA >20- <300kya	Early LSA Howiesons Poort	~18- ~40kya ~58- 66kya	MIS 2- MIS 3 MIS 3-4	AK2006/001G	Orton 2008
				Boomplaas	Pargeter et al 2018
				Sehonghong Rock Shelter	Mitchell 1995; Pargeter & Hampson 2019
				Border Cave	Villa et al 2012
				Airport Site	Thompson et al 2012
				Ntloana Tšoana	Mitchell & Steinberg 1992
				Rose Cottage Cave	Harper 1997
Sibudu Cave	Delagnes et al 2006; Wadley 2008; de la Pena & Wadley 2014; de la Pena et al 2018				
Early MSA	~130- 300kya	MIS 6-8	Pinnacle Point	Bird et al 2007	
			Wonderwerk Cave	Beaumont & Bednarik 2012	

**Table 5:** Some MSA and LSA sites in southern Africa where “crystal quartz” have been mentioned.

## **CHAPTER FOUR**

### **4. Materials and Methods**

#### **4.1. Introduction**

This section elaborates on the materials and methods employed in this study of the crystals recovered from the MSA and LSA occupations at Pomongwe Cave. The material under study is a mineral with a specific geometry and this influenced how the material was selected by the prehistoric humans. The chapter will give an account of the mineral's crystallographic characteristics (See Table 7), expressing more on the physical properties and morphology of the crystal quartz. Technological analysis of crystal quartz has never been applied to African contexts and the various studies conducted on this mineral mostly comes from the Palaeolithic, Mesolithic and Neolithic contexts. Hence most of the methods discussed in this chapter have been developed specifically for this study.

#### **4.2. Materials**

The material under study is crystal quartz from PMG and is housed at the Zimbabwe Museum of Human Sciences. Crystal quartz is a variety of quartz which is characterised by its hyaline appearance and ordered atomic structure, which determines its specific knapping methods following its internal structure (Morgado et al 2016; Novikov & Radililovsky 1990; Inizan et al 1999). It is also referred to as the colourless and transparent variety of quartz (Sachanbinski et al 2008; Petrin et al 2012), however, this definition of crystal quartz seem to have loopholes as the material is found in various colours and with a specific structure which differentiates it from other varieties of quartz. Petrin et al (2012) also note that the identification of this mineral should not be on the basis of transparency and colourlessness. Crystal quartz is a mineral which develops in the form of columnar-prismatic tendency with the well-developed faces of a hexagonal prism (Novikov & Radililovsky 1990). Each crystal quartz piece is a faceted cylinder with well demarcated ridges between each of its crystal faces (Kannegaard 2015) (See

Figure 8). This mineral possesses specific characteristics that are its physical structure and its morphology, to be discussed further below.

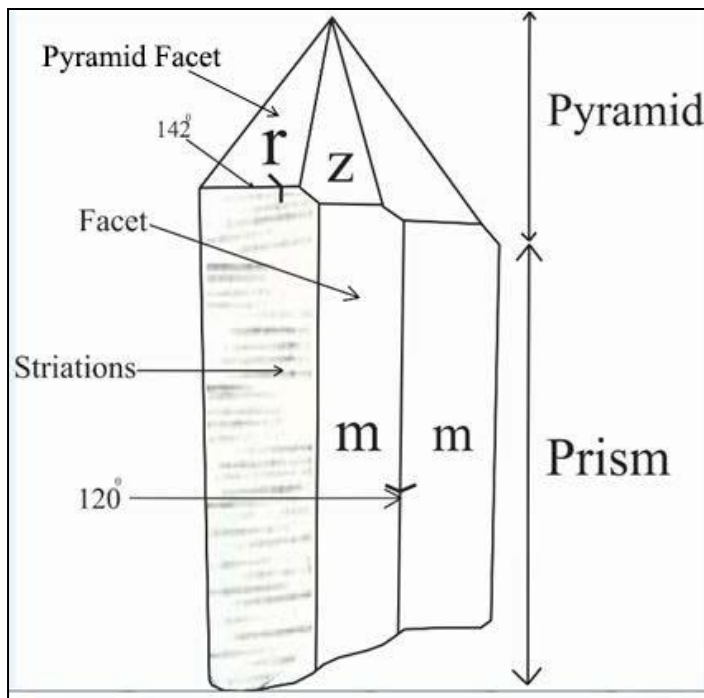

**Figure 8:** *Constant characters of natural crystal quartz.*

#### **4.2.1. Physical Properties**

Quartz is a chemical compound of silicon and oxygen, (silicon dioxide  $\text{SiO}_2$ ), is one of the most abundant minerals in the Earth's crust. According to Dana & Ford 1922:1 "A Mineral is a body produced by the processes of inorganic nature, having a definite chemical composition and, if formed under favorable conditions, a certain characteristic molecular structure which is exhibited in its crystalline form and other physical properties." The mineral occurs in igneous, sedimentary and metamorphic rocks as a vital component (Novikov & Radililovsky 1990; Kannegaard 2015). It can be found in various geological environments, and its various formation conditions can be visually seen. As mentioned earlier in the memoir, quartz can generally be subdivided into two forms which are cryptocrystalline (microcrystalline) and macrocrystalline, and crystal quartz is a form of the macrocrystalline quartz. Crystal quartz typically forms in hot watery solutions, in so-called '**hydrothermal environments**', at temperatures between  $100^\circ\text{C}$  and  $450^\circ\text{C}$  and often at very high pressures:

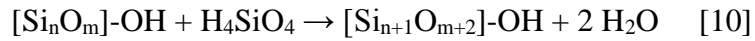

This hydrothermal process takes place in veins and in geological settings which range from alpine to epithermal (Kannegaard 2015). The formation process is linked directly to the circulation of magmatic-related hydrothermal solutions derived by juvenile products of magmatic activity (Petrovic et al 2015). They form from the cooling of the magma which is evident in Silicon Dioxide ( $\text{SiO}_2$ ). The mineral is considered to be very hard; ranking 7 on Moh's scale of hardness this is a qualitative ordinal scale that characterizes the scratch resistance of various minerals through the ability of a harder material to scratch a softer material. The mineral also has varying degrees of transparency (diaphaneity/pellucidity); crystal quartz can either be transparent, translucent or opaque. This was measured for this study as it is one of the properties which can aide to understand the raw material economies of the PMG inhabitants. There is also notable variability in the colour of the crystal quartz, though they have a general tendency to be transparent. Dana & Ford (1922:178) note that "the transparency of crystals is often destroyed by disturbed crystallization; by impurities taken up from the solution during the process of crystallization,..." these impurities are often called inclusions and they appear in three different forms: a) **protogenetic**, b) **syngenetic** and c) **epigenetic** and they can be in liquid, solid or gaseous form and visible to the naked eye. These trace elements involved in the formation of the crystals result in the variations in colour and transparency (Anthony et al 2001). Inclusions of miniature amounts of iron-based minerals, or those based on titanium, lithium, manganese or aluminium leads to the different coloured variations ranging from yellow to black, pink or violet (Reher & Frison 1991).

Crystal quartz like most cryptocrystalline materials fractures in a conchoidal manner when knapped. However, this material possesses some unique problems which are not found in the other cryptocrystalline materials. One of the most important properties of this material which might have affected the use of this material by prehistoric humans is the marked anisotropy of

the crystal's physical properties (Novikov & Radililovsky 1990). Anisotropy is the ability by the material to exhibit properties with different values when measured in different axis. When properties of a material vary with different crystallographic orientations, that material is considered to be anisotropic. In crystal quartz, the most substantial indexes of anisotropy are cleavage and dividing (Novikov & Radililovsky 1990). These are the consequence of the mineral's ability to split when struck along certain directions forming relatively smooth wide faces. Reher & Frison (1991:393) note that "the symmetry of this material is determined by a geometry based on very regular molecular lattice and plane alignments as opposed to the more random assortment of molecular alignments in homogenous cryptocrystalline cherts." However, it is noted that not only striking the material can result in cleavage, but also thermal treatment on the material (Fron del 1962).

Crystal quartz also maintains the ability to form irregular conchoidal fractures, mostly occurring in the apical part of the crystal. The fracturing of this mineral is predictable along some planes, especially those that are parallel to the natural faces of the crystal, but fracturing in other directions is also possible (Reher & Frison 1991). The 3 main directions according to the Dana System (Fron del 1962) are parallel to the crystal axis and to the prism facets as well as to the apical rhombohedral facets. Blanks struck from pure crystal quartz exhibit conchoidal fracturing, including distinctive bulb of percussions. The widest planes of flat-conchoidal fracture take place in the sections oriented at large angles to the crystal axis (Fron del 1962).

#### **4.2.2. Morphology**

Crystal quartz is a mineral with a specified geometry/morphology, and this geometry can best be explained under five terms, i.e. crystal system, crystal class, habit, form and twinning. These distinctions all fall under the concepts of the unit cell and point lattice, and they help to better understand the morphology of the crystals. Crystal systems are defined by the angles between the axes of the point lattice and the relative length of the edges of the unit cell, and like every

mineral; quartz belongs to one of the seven crystal classes (See Table 6), i.e.; the trigonal crystal system; though its unit cell is hexagonal. For Crystal quartz therefore, they can be described with the hexagonal crystals terminology (see Figure 9) because of its unique structure to the rest of the quartz varieties. There are four notable axes on the mineral, i.e. **a<sub>1</sub>**, **a<sub>2</sub>**, **a<sub>3</sub>**, and **c**.

Angles	Axes	Crystal System
$\alpha = \beta = \gamma = 90^\circ$	$a = b = c$	Cubic or Isometric
$\alpha = \beta = \gamma = 90^\circ$	$a = b, c \neq a, c \neq b$	Tetragonal
$\alpha = \beta = \gamma = 90^\circ$	$a \neq b \neq c$	Orthorhombic
$\alpha = \beta = \gamma \neq 90^\circ$	$a = b = c$	Trigonal or Rhombohedral
$\alpha = \beta = 90^\circ, \gamma = 120^\circ$	$a = b, c \neq a, c \neq b$	Hexagonal
$\alpha \neq \beta \neq \gamma, \beta = 90^\circ$	$a \neq b \neq c$	Monoclinic
$\alpha \neq \beta \neq \gamma \neq 90^\circ$	$a \neq b \neq c$	Triclinic

**Table 6:** Seven classes crystal systems.

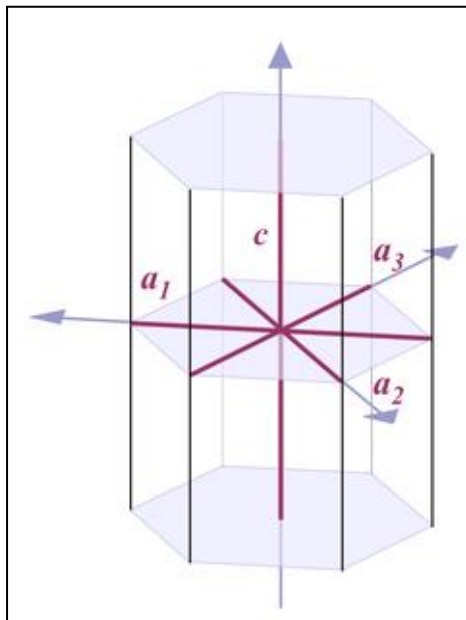

**Figure 9:** Crystal system of crystal quartz.

In terms of the ‘crystal class’, which is the rotation and inversion symmetry properties of a mineral’s crystal lattice, quartz belongs to the trigonal-trapezohedral. According to the Dana

system (Fron del 1962:9), crystal quartz “crystallises in the trigonal trapezoidal class of the rhombohedral sub-system. This class is characterised by one axis of three-fold symmetry and three polar axes of two-fold symmetry perpendicular thereto and separated by 120° angles.”

Crystal twinning is also one of the main terms used to distinguish the geometry of crystals. Crystals are termed ‘twinned’ when they compose of 2 or more crystal sub-individuals whose crystal lattices are oriented differently but nevertheless are inter-grown in a law-like, symmetrical manner. These sub-individuals share atoms along their **composition plane**. There are three main twinning laws for quartz, i.e. a) the Dauphiné Law, b) the Brazil Law and the Japan law.

The general shape of the crystals is referred to as the ‘crystal habit,’ this reflects the growth conditions of the crystal. It sets aside the internal structure of the crystals and is depended on the relative sizes of the crystal faces (facets). There are various notable crystal habits, for example ‘the trigonal habit’, ‘the pseudo-cubic habit’, ‘the barrel-like habit’ and ‘the short-prismatic habit’ just to mention a few.

Crystal quartz is distinguished by a stable morphology that consists of a prism with a pyramid at the top (See Figure 8)The pyramid of the crystal is characterised by pyramidal facets, these are the plain natural surface of the pyramid. These facets come in two main forms, r and z facets. The z facets are smaller in size as compared to the r facets and appear in alternation around the pyramid and between these two facets there is an angle though is not constant as with the case of the prism facets and the angle between the prism and the pyramid. There is also notable variability in the morphology of the pyramid, in terms of the number of facets and size of these facets. They vary in numbers from 3-6 pyramidal facets. Also of interest is the variation in the positioning of the pyramid, in some instances, the pyramid is centred in the

growth axis of the crystal, but at times it is off-centred and in other instances there are two pyramid tips (crystal twinning) on the same crystal.

The crystal also comprises of a hexagonal prism. The outer growth surfaces of the prism are referred to as facets. The facets can be identified by characteristic horizontal striations on the mineral's surface which are very often found on the m-face (perpendicular to the c-axis), a very distinctive feature of crystal quartz that helps identifying them even when crystal tips are missing. (Novikov & Radililovsky 1990). Crystal facets can easily be recognised as they present a flat and lacklustre surface and at the contact between two facets is a sharp acute angle of  $120^\circ$ . However, these striations observed on the prism facets are not observed on the pyramidal facets. There, however is some variation to the 'stable morphology' of the prism introduced by prism irregularities (see Figure 10).

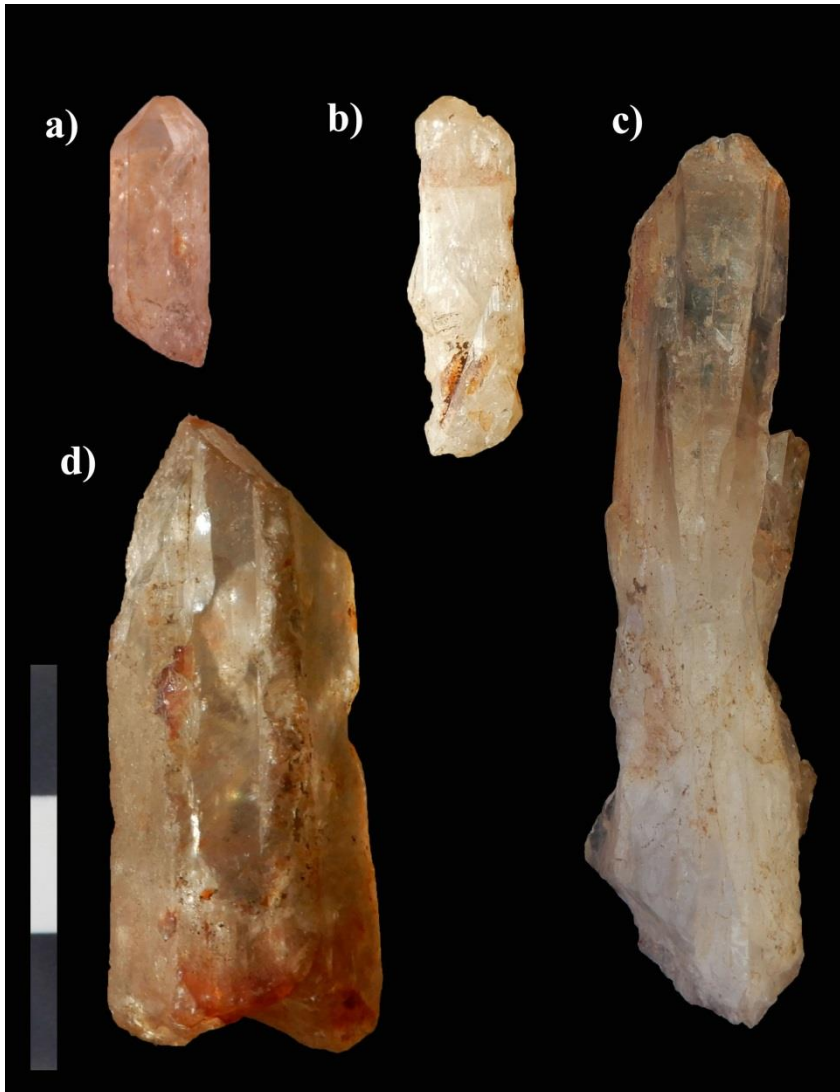

**Figure 10:** *Crystal quartz from Pomongwe Cave showing prisms with various morphologies a) N<sup>o</sup>. 208, layer 14; b) N<sup>o</sup>. 188, layer 13; c) N<sup>o</sup>. 224, layer 12 and d) N<sup>o</sup>.185, layer 13.*

Crystal quartz is also found in varying sizes. They range in size from very tiny prisms to crystals which can grow up to 0.5-0.6m (Anthony et al 2001; Novikov & Radililovsky 1990). The variations in the size range can be attributed to time that the crystal takes to cool-off during its formation. Larger crystals take a longer time to cool than the smaller ones. Crystals of the same length can have different width and thickness. There is no constant ratio between the size of the pyramid and that of the prism.

<b>Mineralogical Classification</b>	
According to <b>Dana</b>	75.1.3.1: Tectosilicates - Si Tetrahedral Frameworks
<b>Crystallographic Data</b>	
Crystal System	Hexagonal / Trigonal
Crystal Class Hermann Mauguin Symbols	Trigonal Trapezohedral 3 2
Space Group	P3 <sub>1</sub> 21 (left hand), P3 <sub>2</sub> 21 (right hand)
Unit Cell Data	a = 4.9133, c = 5.4053 Ratio a:c = 1:1.10013 Z=3
<b>Optical Properties</b>	
Color	colorless if pure, otherwise any color
Streak	none / white if pure
Luster	vitreous Cryptocrystalline: waxy to dull, vitreous if polished
Diaphenity/pellucidity	transparent if pure, otherwise transparent to opaque
Refractive Indices for Na D-Line (589nm)	n <sub>o</sub> =1.54422 n <sub>e</sub> =1.55332 Dispersion=0.0091 Cryptocrystalline: n = 1.53-1.54
Birefringence	uniaxial positive: n <sub>e</sub> -n <sub>o</sub> = +0.00910
Pleochroism / Dichroism	none if pure, weak dichroism is observed in smoky quartz, amethyst, and certain citrines

Optical Activity [ $\gamma$ ] = degrees / mm	$\gamma = 21.73^\circ$ for Na D-Line (589nm)
<b>Electrical Properties</b>	
Relative Permittivity	Dielectric Number $\epsilon_r$ : 4.69 parallel to a-axis $\epsilon_r$ : 5.06 parallel to c-axis
Behavior in Magnetic Fields	Diamagnetic
<b>Mechanical Properties</b>	
Fracture	conchoidal, sometimes uneven
Cleavage	weak tendency to break along rhombohedral and prism planes
Tenacity	Brittle
Mohs Hardness	Macrocrystalline: 7 Cryptocrystalline: 6.5-7
Vicker's Indentation Hardness	Macrocrystalline: average 1182 kg/mm <sup>2</sup> (basal plane 1103 kg/mm <sup>2</sup> , prism faces 1260 kg/mm <sup>2</sup> )
Rosival Grinding Hardness	Macrocrystalline: 100 (quartz is the reference)
Specific Weight	2.6481 g/cm <sup>3</sup>
Melting Point	1705°C
Boiling Point	2477°C
Thermal Conductivity [ $\lambda$ ] = W/m×K	$\lambda = 12.14$ parallel to c-axis $\lambda = 6.70$ parallel to a-axis

**Table 7:** Crystallographic characteristics of quartz (crystal quartz).

### **4.3. Sample Selection**

The research focused on trench I of Cooke, as it provides a long and continuous sequence until bed rock. This trench was also selected because it represents the sector which was re-opened in 2018 for new field campaigns at the site (See Figure 11). Two squares X: C 1-3 and C: E 1-3 were selected for analysis. These two squares were selected because they represent the area in which the whole sequence was exposed by Cooke.



**Figure 11:** *Cooke's trench I re-opened in 2018 (picture by J. Matembo).*

With the nature of crystal quartz fragments, there are often confusions with other varieties of transparent quartz and it's not straightforward to differentiate them from these varieties (Petrin et al 2012, Kannegaard 2015). It is with this in mind that for this research we selected only the pieces which had clear characteristics of crystal quartz. The main characteristic that we identify as typical of crystal quartz, in contrast with other quartz, is the presence of facet/s (defined above). All pieces which showed evidence of complete or partial facet were selected for the research.

All the boxes from Cooke's trench 1 excavation were checked and a total of 578 pieces were selected from the two squares. It should be noted here that the whole sequence was exposed by Cooke in square X: C1-3 while his excavation ended in layer 14 in square C: E1-3. The small difference of numbers between the two squares, though one of them has been excavated more deeply, relates to the fact that most crystal quartz occur above layer 14. Additionally, a general raw material count on all the products was conducted in square X: C1-3 regardless of the dimensions, so as to see the general proportion of crystal quartz in relation to other raw materials that were exploited at PMG (see Table 8).

<b>Techno-complex</b>	<b>Layer</b>	<b>Crystal Quartz</b>	<b>%</b>	<b>Quartz</b>	<b>%</b>	<b>Quartzite</b>	<b>%</b>	<b>Dolerite</b>	<b>%</b>	<b>Chert</b>	<b>%</b>	<b>Total</b>
<b>Amadzimba</b>	<b>3</b>	13	44.8	13	44.8	0	0	0	0	3	10.4	<b>29</b>
<b>Nswatugi</b>	<b>4_6</b>	26	33.8	17	22	1	1.3	2	2.6	31	40.3	<b>77</b>
<b>Pomongwe</b>	<b>8</b>	1	1.2	16	19.1	3	3.6	6	7.1	58	69	<b>84</b>
<b>Maleme</b>	<b>10</b>	15	3.5	282	66.4	8	1.9	22	5.2	98	23.1	<b>425</b>
<b>Maleme</b>	<b>11</b>	49	8	400	65.7	13	2.1	50	8.2	97	15.92	<b>609</b>
<b>Maleme</b>	<b>12</b>	58	12.74	278	61.1	9	1.9	20	4.4	90	19.8	<b>455</b>
<b>Bambata</b>	<b>13</b>	19	4.4	307	70.9	8	1.8	37	8.5	62	14.3	<b>433</b>
<b>Bambata</b>	<b>14</b>	14	5.8	161	66.5	3	1.2	42	17.4	22	9.1	<b>242</b>
<b>Bambata</b>	<b>15</b>	8	3.9	117	57.6	2	1	44	21.7	32	15.8	<b>203</b>
<b>Bambata</b>	<b>16</b>	19	4.9	235	61.4	9	2.3	91	23.7	29	7.6	<b>383</b>
<b>Bambata</b>	<b>17</b>	15	5.5	183	67.5	4	1.5	45	16.6	24	8.8	<b>271</b>
<b>Bambata</b>	<b>19</b>	8	2.2	274	75.7	6	1.7	56	15.5	18	5	<b>362</b>
<b>Bambata</b>	<b>20</b>	10	2.8	311	85.9	4	1.1	23	6.3	14	3.8	<b>362</b>
<b>Bambata</b>	<b>21</b>	14	2.7	417	80.3	11	2.1	60	11.6	17	3.3	<b>519</b>
<b>Bembesi</b>	<b>22</b>	18	2.7	534	79.6	19	2.8	79	11.8	21	3.1	<b>671</b>
<b>Bembesi</b>	<b>24</b>	3	0.85	238	67.8	20	5.7	75	21.4	15	4.3	<b>351</b>
<b>Bembesi</b>	<b>26</b>	0	0	106	60.2	6	3.4	53	30.1	11	6.3	<b>176</b>
<b>Bembesi</b>	<b>27</b>	0	0	19	73	1	3.8	5	19.2	1	3.8	<b>26</b>
<b>Total</b>		<b>290</b>	5.1	<b>3908</b>	68.8	<b>127</b>	2.2	<b>710</b>	12.5	<b>643</b>	11.2	<b>5678</b>

**Table 8:** Showing the proportions of exploited Raw materials in Square X: C1-3.

#### **4.4. Problems Faced**

There were some challenges which were encountered during the selection of the sample for the study. (1) The major challenge was there were some layers which were not represented in the available collections. For example in square X:C1-3, layers 7, 9, 18, 23 and 25 are missing from the collections but it is not clear if it results as an absence of these layers in the particular square or if the bags are missing. (2) Additionally in square C: E1-3 there was no crystals in layers 4, 6, 7 and 8. This is yet not sure if there were no crystals recorded in the layers of this specific square or if the crystal quartz were removed from their initial bags. (3) Another challenge was that of differentiating crystal quartz facets from cleavage planes where the natural surface was minimal. In that specific case, the use of a binocular microscope to look for the striations and/or specific angles helped to establish the distinction.

#### **4.5. Methods**

This research is a technological analysis of crystal quartz and seeks to understand how this mineral was exploited for lithic production at PMG. Technological studies seek to categorize lithic artefacts within suitable technical contexts. For this study, the analysis followed the principles of the *chaîne opératoire* approach.

##### **4.5.1. Chaîne Opératoire Approach**

The concept of *chaîne opératoire* was originated by André Leroi-Gourhan (1993, originally 1964), as a methodology for scrutinizing and understanding the technical actions undertaken in the production, use and discard of material culture, especially from a social, cognitive and evolutionary perspective (Driscoll 2010). This concept has best been described by Boëda (1995:43) as, “a series of operations which brings primary material from the natural state to a fabricated state.” This is an approach that generally targets at reconstructing the manufacture steps that are evident within an assemblage; which has its pedigree in French anthropology (Högberg & Larsson 2011). The approach relies on the principle which was defined by Tixier (1980):

“Technology is not typology. It takes into account the entire lithic material without preferentially isolating what we choose arbitrarily to call “tools.” It places each item in the sequence of technical actions beginning (after its conception and prior contemplation) with the raw material and ending with the abandonment, the “death” of the tool assemblage. Even when fragmented into thousands of microliths and “debris,” a lithic assemblage always forms a coherent whole bound together by a methodical scheme.” (After Bar-Yosef & Van Peer (2009); their French translation).

The approach since its inception in the 1960s has been used to analyse a wide array of materials and techniques (Lemonnier 1993; Schlanger 1994; 2005; Audouze 2002; Sørensen & Desrosiers 2008). The approach have also been discussed, criticized, developed and applied in many studies on lithic technologies (Inizan et al 1999; Bleed 2001; Shott 2003; Soriano et al 2007; Modikwa 2008; Bar-Yosef & Van Peer 2009; Soressi & Geneste 2011; Porraz et al 2016). *Chaîne opératoire* incorporates all the processes with regards to raw material collection, manufacture, use, through to the discard of the products. According to Inizan et al 1999: 12, “The chaîne opératoire structures man’s use of materials by placing each artefact in a technical context, and offers a methodological framework for each level of interpretation.” It signifies the idea that technologies are socially emphasized actions.

The study reconstructed all the different stages of the materials exploitation, from collection through to use and discard of the products and cores. However I acknowledge that, due to my criteria of selection that does not consider crystal quartz pieces without facets, the description of the *chaînes opératoire* should be considered as incomplete. The study of translucent quartz without facets (assumedly crystal quartz) will be performed in a near future.

For purposes of the analysis, crystal quartz pieces were classified into 3 main categories that are (1) the unmodified crystals, (2) the modified crystal and (3) the blanks.

(1) **Unmodified crystals** are crystals which are complete and do not show any signs of intentional modification. The category is further divided into two groups that are (a) raw crystals and (b) 'used' crystals.

(1a) the raw crystals show no evidence of post-collect scars and intentional removals.

(1b) 'used' crystals are those that show possible functional traces (, i.e. not intentional), which are interpreted as incidental removals that occurred during use.

There are possible functional traces/scars that are visible on low magnification (x10) on the crystal pieces. These scars present different morphologies and take the form of a single removal, multiple removals, unifacial scarring, bifacial scarring or rounding of the tip and /or edges. The morphology of these scars differentiates them from the intentional removals that present distinct impact points and negative bulbs of percussion.

For this research, the pattern of the scars and their location was recorded so that they could help to interpret their origin(s). The scars are found on either the tip or the edges of the pyramid (ridges between the two facets).

(2) **The modified crystals** are crystals with its prism and with or without the pyramid. The modified crystals show evidence of intentional removals/knapping and were also further classified into two main classes: (a) cores and (b) tools.

(2a) the core was determined by the presence of intentional removal/s on the crystal.

(2b) the tools were classified as such when purported functional traces were observed on the knapped edges of the crystal piece.

(3) **The blanks** represent all products of the knapping process of crystal quartz. They result from the exploitation of crystal quartz and were categorised into flakes, blades, bladelets, micro-flakes and fragments. For the classification of these blanks, we

followed the classification of Porraz et al (2016). Flakes were distinguished from blades based on their dimensions. The blades category comprise of all blanks with sub-parallel to convergent edges that are twice as long (or longer) than wide (Porraz et al 2016). Different size ranges were distinguished for all the categories; blades ( $\geq 12\text{mm}$ ), bladelets ( $\leq 11\text{mm}$ ) and flakes were also distinguished from micro flakes ( $\leq 20\text{mm}$ ).

The dimensions of all the selected pieces were measured in-line with questions of this research which are: a) to understand the selection of crystal quartz, whether there was variation or not in the sizes of the selected crystals; b) to understand the technology on crystal quartz, i.e. the dimensions of the discard of cores and the sizes of blanks produced. A Vernier calliper was used to take these measurements and they were recorded in millimetres (mm).

The dimensions of the unmodified crystal were measured as follows. The maximum length was measured in the axis of growth of the crystal, from the base of the crystal to the tip of the pyramid; the maximum width was measured perpendicular to the axis of growth but on the edges of the prism and the maximum thickness was measured on the intersection of the length and width on the facets, perpendicular to the axis of the width.

Dimensions of the modified crystals were also taken from various positions. For crystals in this category, two set of dimensions were recorded on the cores in-line with the question of this research mentioned above. The maximum length was measured in the technological axis, the maximum width perpendicular to the length (at the middle of the piece) and the thickness at the intersection of the two (length and width). In the case of cores, two separate measurements were taken, i.e. one in relation to the morphology of the crystal and the other one in relation to technology (in terms of the integrity of the crystals they were considered not to be complete but technologically speaking they were complete).

The maximum length of the blanks was measured in the technological axis (within the axis of percussion), the maximum width (perpendicular to the technological axis, at the middle of the piece) and the maximum thickness (at the intersection between the length and the width).

#### **4.5.2. Identification**

All selected pieces were bagged individually and each piece was ascribed to a label in the individual bag. The information on the labels included the year of excavation, square, layer, the chrono-cultural phase in which the piece was derived from, the unique identification number of the piece. These numbers were ascribed at random in each square, from the top to the bottom of the sequence. The numbers were used to individually record the pieces in the database.

#### **4.5.3. Natural Surface**

The condition of the natural surface of the crystals was also recorded for the purpose of this research. This surface was examined to see if it was fresh or weathered. Fresh surface means that the crystals was hardly exposed to atmospheric agents and might have been sourced close to the primary context. The weathered surface is characterised by rolling marks and rounding on the edges of the facets; such surfaces entails that the crystals have been exposed to natural transport (e.g. water) and have likely been sourced in a secondary context. The natural surface was also examined to the state of preservation of the crystals, whether they were exposed to fire, or the different levels of patina (i.e. superficial alteration of the colour).

#### **4.5.4. Integrity**

The integrity of the pieces refers to whether the crystal piece is fragmented or not. On the unmodified crystals, the orientation follows the axis of growth of the crystal and on the modified crystals and blanks; the orientation follows the axis of technology. For the research, the integrity was coded with numbers (see Figure 12).

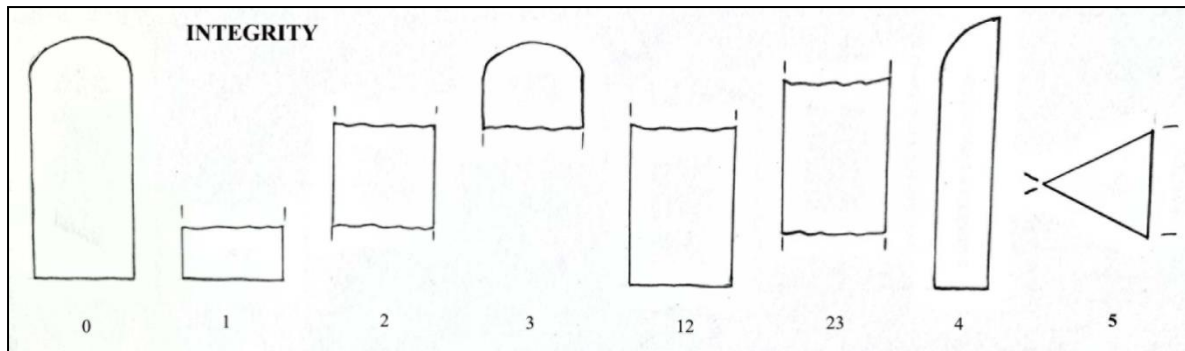

**Figure 12:** *The integrity of the crystals and blanks.*

#### **4.5.5. Reduction Strategies**

The main focus of this research is to characterize the crystal quartz reduction sequences at PMG. Since very little is known on crystal quartz technologies and as crystal quartz has specific structural properties, the study came up with a logical analytical scheme to describe the technological stages of crystal quartz exploitation. An alpha-numeric scheme was designed (see Figure 13) drawing comparisons from Sauter et al 1971 (See Figure 14), such that the letters provide the stages and development of reduction sequence in relation to the geometry of the crystal and the number represent the direction and position of the force that was applied to fracture the crystal.

The letters are coded from A-G;

**A** represents the first flake either from the pyramid or the base.

**B** can be the second removal from either the base or the pyramid; the platform is not a natural surface.

**C** represents a removal with a natural surface platform either from the pyramid or the base, but differs from A in that its dorsal face is not fully cortical.

**D** represents the oblique symmetric or asymmetric removals from either the top or the base of the crystal.

**E** represents the longitudinal removals or splits of the crystal;

**F** on the contrary represents transversal knapping and removals.

The last letter is **G** which represents all the indeterminate pieces.

The letters explained above work in collaboration with the numbers here explained. The numbers represent the direction of knapping and the position of the piece within the geometry of the crystal. This direction is classified with six numbers:

**1** represents knapping from the bottom of the crystal, it has a variance of  $22.5^\circ$  from the axis of growth of the crystal.

**2** represent an oblique knapping also from the bottom of the crystal. It has a variance of  $45^\circ$  from the axis of growth of the crystal;

**3** represent transversal knapping;

**4** and **5** represents the same as **1** and **2** but from the pyramid respectively;

**6** represent the indeterminate pieces.

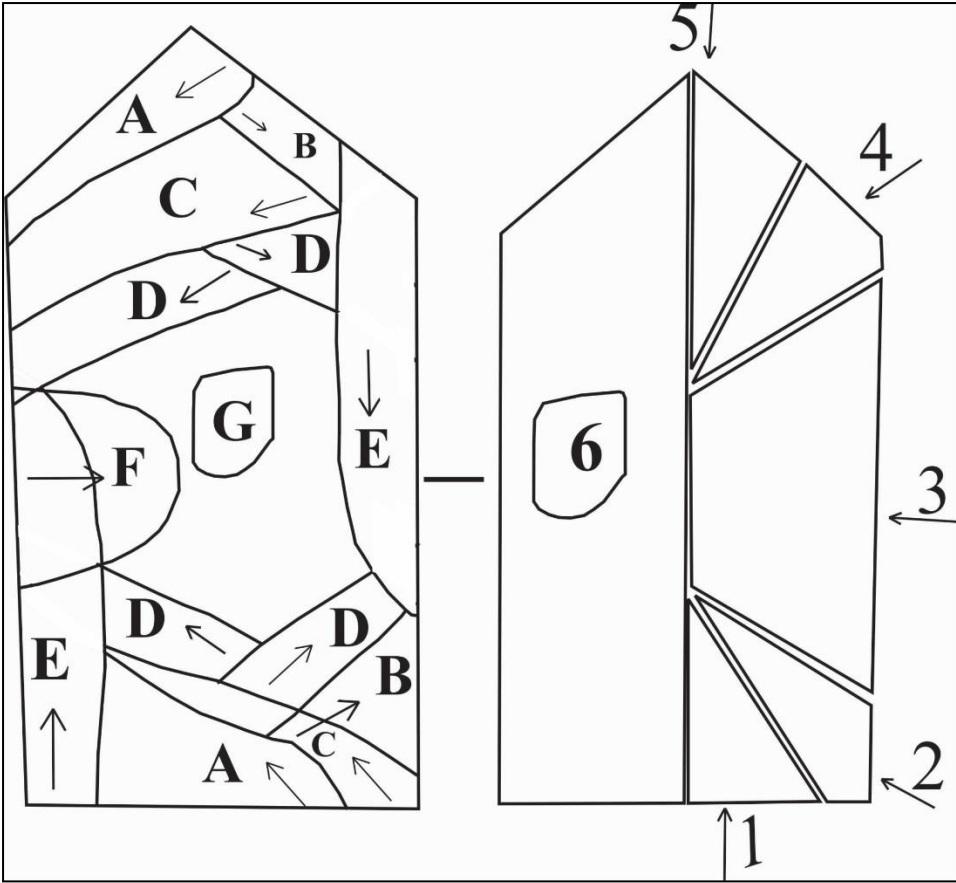

**Figure 13:** *The Alpha-numeric Scheme designed for the technological analysis of crystal quartz. The letters provide the stages and development of the removals within the geometry of the crystal; the numbers represent the direction of the removals according to the natural axis of the crystal.*

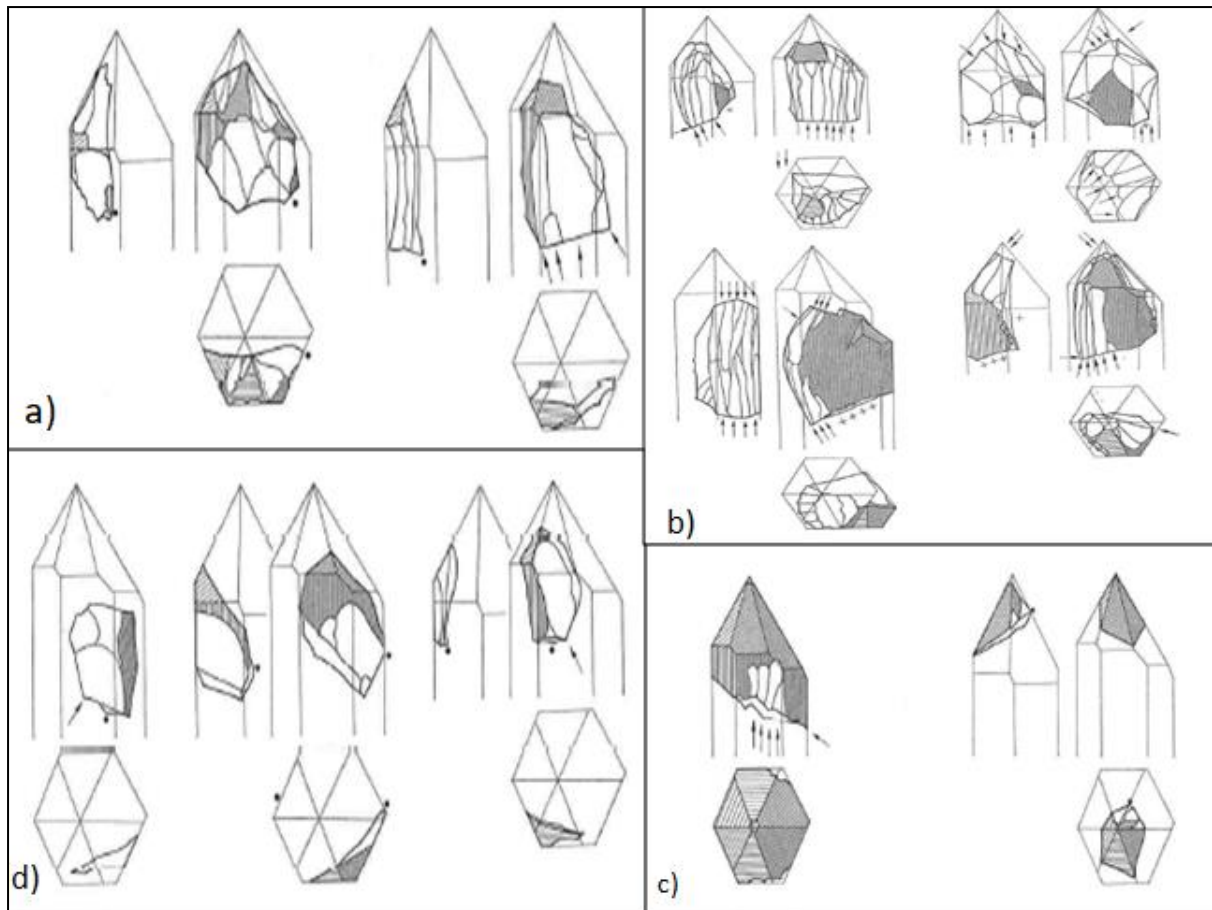

**Figure 14:** Diagrams showing main debitage products a) transversal fragmentation of the prism, b) prism thinning, c) cortical removal and d) debitage production (After Sauter et al 1971).

#### **4.5.6. Technique**

The research also aimed at assessing the techniques which were employed in the exploitation of crystal quartz at PMG. The categorization of the techniques of detachment of blanks combines observations on the cores and on the products (see Porraz et al 2016, Soriano et al 2007). The categorization was based on the description of the striking platform, the platform was described, platform dimensions were taken, and the overhang examined to look for any traces of preparation. The ventral and dorsal surfaces were examined for possible removals.

## **CHAPTER FIVE**

### **5. Study Results**

#### **5.1 Introduction**

The pith of this chapter is to present the data from the technological analysis of the crystals and the results obtained. Data presented comprises the sample size, the classification of the crystals, and diaphaneity of the crystals, the natural surfaces and peculiarities, integrity, metric measurements morphology of the crystals, technology, and techniques. It includes results on the analysis of the blanks and their different forms.

#### **5.2 Sample size**

The research sampled all the crystal quartz pieces from Cooke's trench I (Sq. X: E 1-3) collections. The crystals were sampled from layers 24-3 which cover the MSA and LSA sequence at PMG. Layer 3 had 76 crystal quartz piece (13.1%); layer 5 had 7 pieces (1.2%); layer 6, 26 pieces (4.5%); layer 8, 1 piece (0.2%); layer 9, 2 pieces (0.3%). The quantities started to increase from layer 10 which had 20 pieces (3.5%); layer 11 had the highest numbers of crystal quartz recovered with 165 pieces (28.5%); layer 12 had 110 pieces (19%); layer 13 had 48 pieces (8.3%); layer 14 had 28 pieces (4.8%). The quantities of the crystal quartz started to change again from layer 15 downwards, there was more notable variation within the layers; layer 15 had 8 pieces (1.4%); layer 16 had 19 pieces (3.3%); layer 17 had 15 (2.6%); layer 19 had 8 pieces (1.4%); layer 20 had 10 pieces (1.7%); layer 21, 14 pieces (2.4%); layer 22, 18 pieces (3.1%) and lastly layer 24 with 3 pieces (0.5%). There are some layers which were not represented with the available collections at the ZMHS which are layers 4, 7, 18, and 23. To notice that there were no crystals in the lowermost layers 25-27. As such, a total of 578 crystal quartz pieces were collected for this study.

### **5.3. Crystal quartz general attributes**

#### **5.3.1. Diaphaneity**

Three main varieties of crystal quartz were observed based on the diaphaneity, i.e. transparent, semi-transparent and opaque. The results show that 127 crystal quartz pieces were transparent (22%) of the total collection; 278 pieces (48.1%) were semi-transparent and 173 pieces (29.9%) were opaque. This suggests that crystals with various diaphaneity were available in the landscape and that diaphaneity was not a rigid criterion of selection for PMG inhabitants. Table 9 below presents the results of the diaphaneity per layer.

Layer	Transparent	Semi-Transparent	Opaque	Totals
3	23	37	16	76
5	0	3	4	7
6	10	7	9	26
8	0	1	0	1
9	2	0	0	2
10	6	9	5	20
11	26	92	47	165
12	14	54	42	110
13	20	18	10	48
14	10	13	5	28
15	0	2	6	8
16	3	12	4	19
17	2	8	5	15
19	1	5	2	8
20	3	3	4	10
21	2	4	8	14
22	4	9	5	18
24	1	1	1	3
Totals	127	278	173	578

**Table 9:** *Frequencies of the crystal quartz diaphaneity per layer.*

#### **5.3.2. Inclusions**

The results show that four types of colour inclusions were macroscopically observed on the PMG crystal quartz, i.e. reddish, blackish, pinkish and smoked. Most of the crystals selected however had no inclusions within n=357 (61.8%), throughout the sequence (See Figure 15, Table 10). Of those with inclusions, the reddish inclusion had the highest numbers n=151 (26.1%); followed by the blackish n=46 (7.9%); pinkish n=22 (3.8%) and 2 smoked crystals quartz (0.3%).

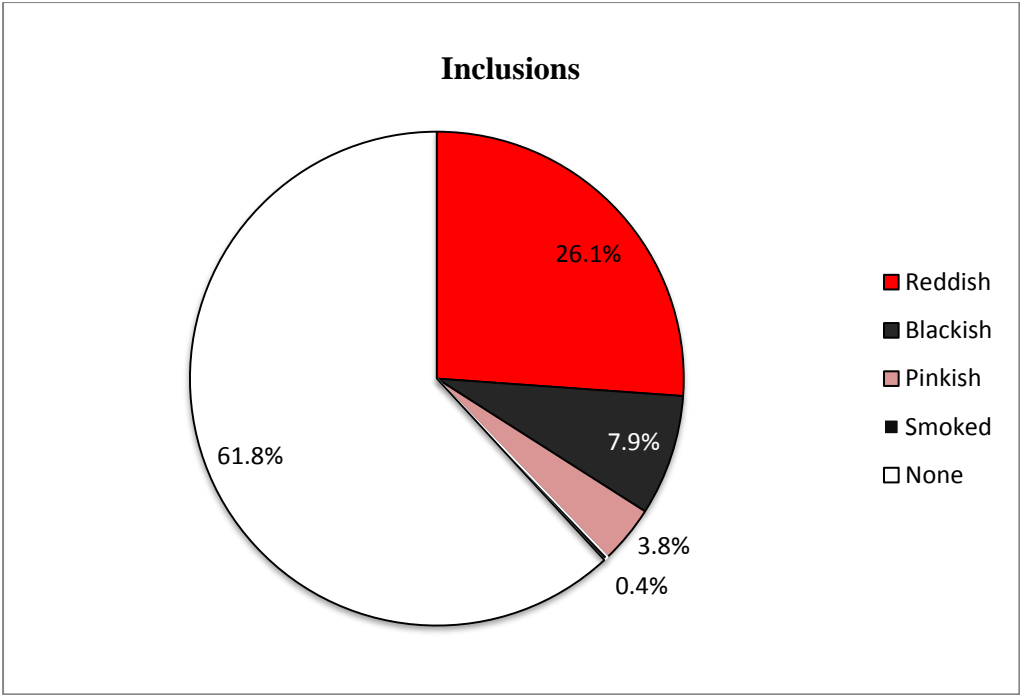

**Figure 15:** Chart showing crystal quartz inclusions frequencies.

Phase	Layer	Reddish		Blackish		Pinkish		Smoked		None	
		N <sup>o</sup> :	%	N <sup>o</sup> :	%	N <sup>o</sup> :	%	N <sup>o</sup> :	%	N <sup>o</sup> :	%
Amadzimba	3	14	18.4	9	11.8	1	1.3	0	0	52	68.4
Nswatugi	5	0	0	0	0	0	0	0	0	7	100
Nswatugi	6	2	7.7	3	11.5	0	0	0	0	21	80.8
Pomongwe	8	0	0	0	0	0	0	0	0	1	100
Pomongwe	9	1	50	0	0	0	0	0	0	1	50
Maleme	10	5	25	5	25	0	0	0	0	10	50
Maleme	11	66	40	11	6.7	11	6.7	0	0	77	46.7
Maleme	12	40	36.4	14	12.7	2	1.8	0	0	54	49.1
Bambata	13	12	25	3	6.2	6	12.5	0	0	27	56.2
Bambata	14	6	21.4	0	0	1	3.6	0	0	21	75
Bambata	15	0	0	0	0	0	0	0	0	8	100
Bambata	16	1	5.3	0	0	0	0	0	0	18	94.7
Bambata	17	1	6.7	0	0	0	0	1	6.7	13	86.7
Bambata	19	0	0	0	0	1	12.5	1	12.5	6	75
Bambata	20	0	0	0	0	0	0	0	0	10	100
Bambata	21	2	14.3	1	7.1	0	0	0	0	11	78.6
Bembesi	22	1	5.5	0	0	0	0	0	0	17	94.4
Bembesi	24	0	0	0	0	0	0	0	0	3	100
	Totals	151	26.1	46	7.9	22	3.8	2	0.3	357	61.8

**Table 10:** Frequencies of colour inclusions on the crystal quartz per layer.

### 5.3.3. Natural Surface

The results show that most of the crystals have a weathered surface, i.e. 425 pieces (73.5%) while 153 pieces (26.5%) were fresh. The differences in the natural surface show that the material was sourced from different provenances. Figure 16 below presents the frequencies of the natural surface per layer.

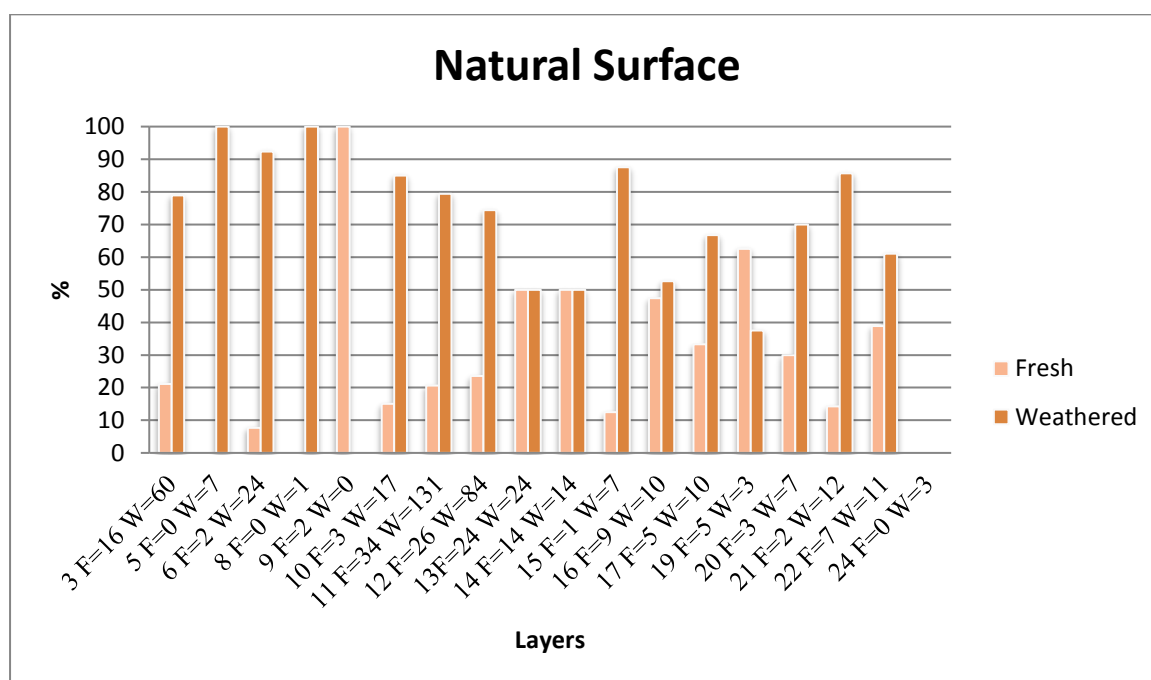

**Figure 16:** Results of the natural surface examination per layer.

#### **5.4. Classification of the crystal quartz pieces**

The crystals were technologically classified into three main categories, i.e. unmodified crystals (n=152, i.e. 26.3% of the total collection), modified crystals (n=169, 29.2%) and blanks (n=257, 44.5%) (See Figure 17).

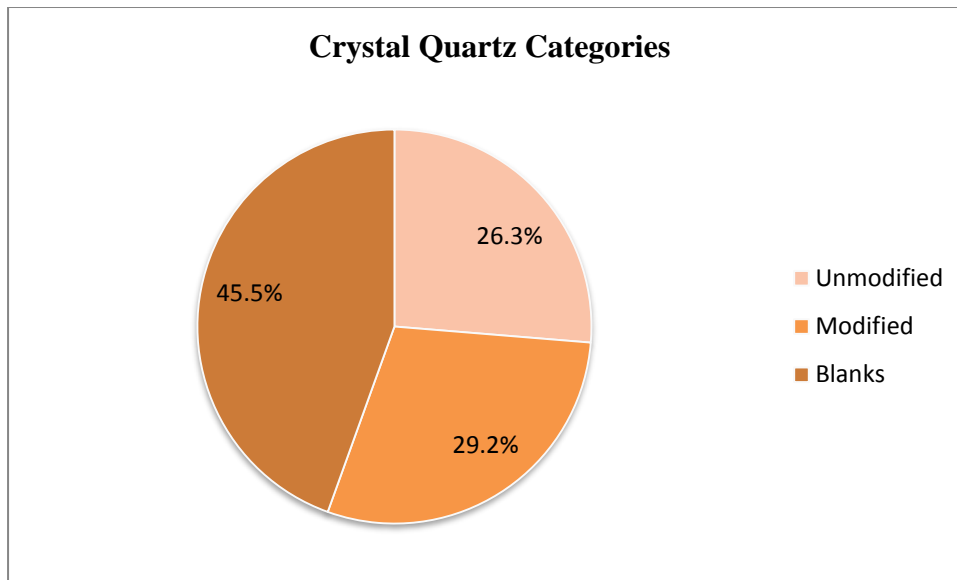

**Figure 17:** *Showing the percentage of the different categories of the selected crystals.*

These main categories were further subdivided on technological grounds. The unmodified category were further subdivided into raw and used crystals, the modified crystals were subdivided into cores, tools and indeterminate pieces and the blanks were further divided into five technological classes', i.e. flakes, blades, bladelets, micro-flakes and lastly fragments (Table 11 below shows the quantities of the different categories per layer).

Techno-complex	Layer	Unmodified		Modified		Blanks					TOTAL
		Raw	Used	Cores	Tools	Flakes	Blades	Micro-flakes	Bladelets	Fragments	
<b>Amadzimba</b>	<b>3</b>	4	3	25	5	4	–	12	3	19	76
<b>Nswatugi</b>	<b>5</b>	0	0	0	0	3	1	1	1	1	7
<b>Nswatugi</b>	<b>6</b>	0	0	6	0	5	2	6	0	7	26
<b>Pomongwe</b>	<b>8</b>	0	0	0	0	1	0	0	0	0	1
<b>Pomongwe</b>	<b>9</b>	1	0	0	0	0	0	1	0	0	2
<b>Maleme</b>	<b>10</b>	2	1	5	1	4	0	0	1	6	20
<b>Maleme</b>	<b>11</b>	33	25	34	4	27	0	3	5	31	165
<b>Maleme</b>	<b>12</b>	19	15	35	4	17	2	1	0	14	110
<b>Bambata</b>	<b>13</b>	11	7	11	1	10	0	2	4	2	48
<b>Bambata</b>	<b>14</b>	6	5	7	1	8	0	0	0	1	28
<b>Bambata</b>	<b>15</b>	4	2	0	0	1	0	0	0	1	8
<b>Bambata</b>	<b>16</b>	2	2	7	0	5	0	0	1	2	19
<b>Bambata</b>	<b>17</b>	1	1	3	0	4	1	0	0	5	15
<b>Bambata</b>	<b>19</b>	2	3	0	1	2	0	0	0	0	8
<b>Bambata</b>	<b>20</b>	0	0	2	0	5	0	0	0	3	10
<b>Bambata</b>	<b>21</b>	2	1	2	0	7	1	0	0	1	14
<b>Bembesi</b>	<b>22</b>	0	0	5	0	10	0	0	0	3	18
<b>Bembesi</b>	<b>24</b>	0	0	2	1	0	0	0	0	0	3
	<b>TOTAL</b>	<b>87</b>	<b>65</b>	<b>144</b>	<b>18</b>	<b>113</b>	<b>7</b>	<b>26</b>	<b>15</b>	<b>96</b>	<b>578</b>

**Table 11:** *The different categories of crystal quartz per layer throughout the sequence.*

### **5.5. Unmodified Crystals**

The sampled assemblage had a fair frequency of unmodified crystals; they constituted 26.3% of the total selected sample (See Figure 18). The unmodified crystals were further divided into two main categories, i.e. raw n=87 (57.2%) and ‘used-unmodified’ n=65 (42.8%) crystals.

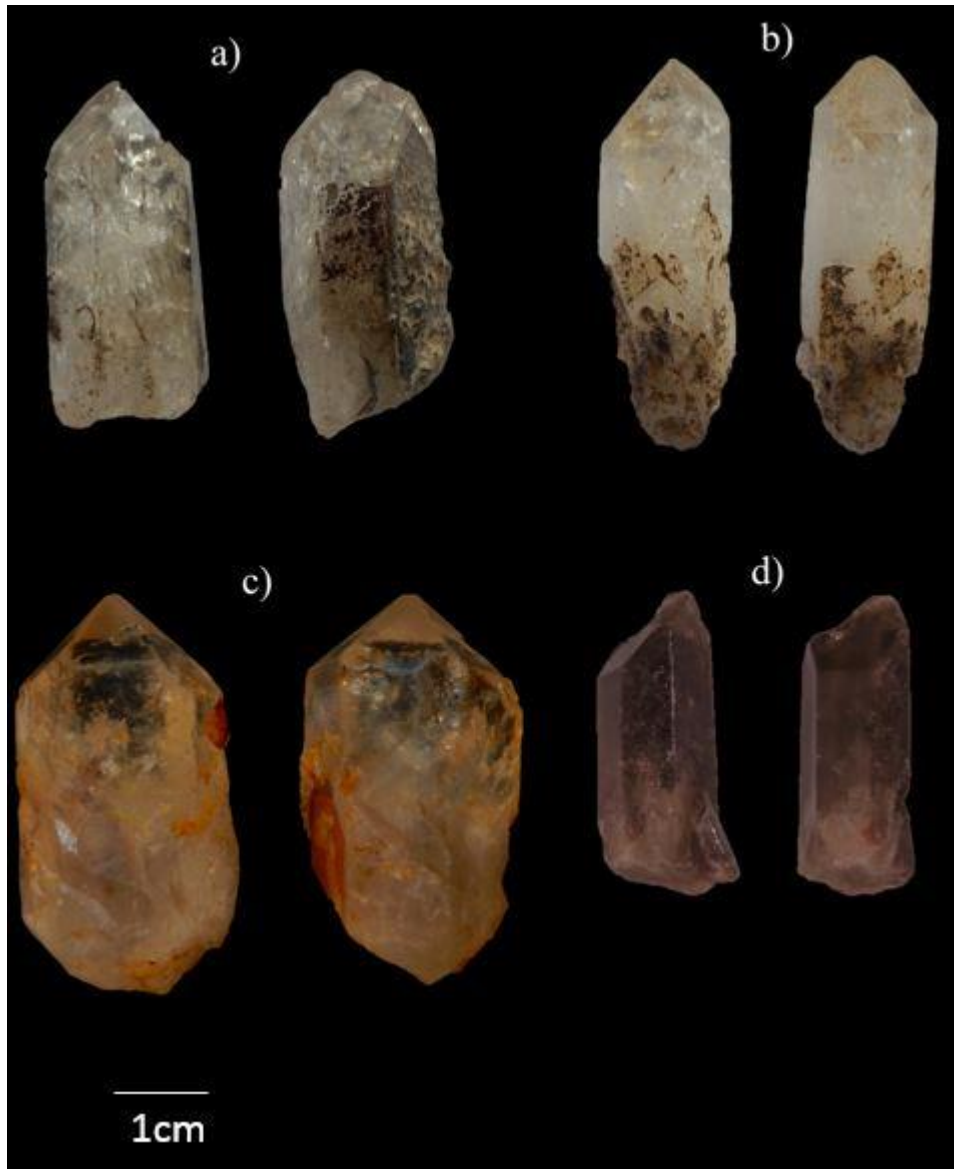

**Figure 18:** *Unmodified crystal quartz pieces from different layers, i.e. a) layer 3, N° 57; b) layer 3, N° 4; c) layer 11, N° 92 and d) layer 19 N° 257.*

The results show that there was variation in the distribution of the unmodified crystals at PMG throughout the sequence. The majority of the unmodified crystal quartz was recovered between layers 11-13. It seems during these periods, crystal quartz was significant at PMG because of the high number of both raw and 'used-unmodified' crystals recovered. The study shows that in most layers throughout the sequence the raw crystal dominated more as compared to the 'used-unmodified' crystals variant. Also to note is the number of layers where unmodified crystals were absent, i.e. layers 5, 6, 8, 20, 22 and 24. This absence can either be explained by a) low quantities of crystals quartz in these layers as a whole b) due to the spatial organization of the PMG and c) it documents different intentions or curation of the material by the PMG inhabitants.

The results of the study have shown that 90.1% (n=137) of the unmodified crystals were complete ( $\emptyset$ ) and the remaining 9.90% (n=15) were not modified but fragmented either before being introduced to the site or as a result of use. The raw crystals showed no evidence of post-collect scars and intentional removals, whereas the 'used unmodified' crystals had evidence showing possible functional traces (i.e. not intentional), which are interpreted as incidental removals that occurred during use. Table 12 below shows the detailed results of integrity of the unmodified crystals per layer.

Layer	Ø	1	2	3	12	23	4	5	Total
3	6	0	0	0	1	0	0	0	7
9	1	0	0	0	0	0	0	0	1
10	2	0	0	1	0	0	0	0	3
11	52	0	0	0	6	0	0	0	58
12	34	0	0	0	0	0	0	0	34
13	18	0	0	0	0	0	0	0	18
14	10	0	0	0	1	0	0	0	11
15	3	0	0	0	3	0	0	0	6
16	4	0	0	0	0	0	0	0	4
17	2	0	0	0	0	0	0	0	2
19	3	1	0	0	1	0	0	0	5
21	2	0	0	0	0	1	0	0	3
<b>Total</b>	137	1	0	1	12	1	0	0	152

**Table 12:** Results of the integrity of unmodified crystals per layer.

The results of metric measurements show that there is variation in terms of length, width and thickness dimensions among unmodified crystals (See Table 13). Length measurements were established on 137 crystals (90.1%) of the total unmodified crystals, these were the pieces which were complete from the base to the tip on both ends. Width measurements were recorded on 151 crystals (99.3%) of the total unmodified crystals and the thickness measurements was based on 148 (97.3%) crystal pieces.

Phase	Layer	LENGTH					WIDTH					THICKNESS				
		Number	MIN	MAX	MEAN	STDEV	Number	MIN	MAX	MEAN	STDEV	Number	MIN	MAX	MEAN	STDEV
<b>Amadzimba</b>	3	<b>6</b>	22	39	32,167	6,5549	<b>7</b>	9	19	12,9143	3,7747	<b>7</b>	8	16	10,57	3,155
<b>Pomongwe</b>	9	<b>1</b>	17	17			<b>1</b>	7	7			<b>1</b>	5	5		
<b>Maleme</b>	10	<b>2</b>	27	31	29	2,82843	<b>3</b>	12,2	13,5	12,9	0,6557	<b>3</b>	8	11	9,667	1,528
<b>Maleme</b>	11	<b>56</b>	31	55	30,696	7,71285	<b>58</b>	6	27,9	12,3491	3,7413	<b>58</b>	4	22	9,571	2,996
<b>Maleme</b>	12	<b>34</b>	18	62	31,118	8,57327	<b>34</b>	8	20	12,8824	3,3099	<b>34</b>	6	13	9,063	2,124
<b>Bambata</b>	13	<b>18</b>	21	72,5	33,128	11,609	<b>18</b>	5	31,2	14,7889	6,4883	<b>18</b>	3,3	25	10,81	4,517
<b>Bambata</b>	14	<b>10</b>	16,5	48,9	30,63	11,0749	<b>11</b>	10,2	24,6	12,9182	3,9524	<b>11</b>	7	20	9,645	3,663
<b>Bambata</b>	15	<b>3</b>	36	45,5	40,833	4,75219	<b>6</b>	14,5	26	20,3333	4,4008	<b>6</b>	11	22	16,17	4,309
<b>Bambata</b>	16	<b>4</b>	26,5	49	36,875	9,27699	<b>4</b>	11,5	28,5	20,125	7,0163	<b>4</b>	7,5	17,5	13,38	4,25
<b>Bambata</b>	17	<b>2</b>	39	75	57	25,4558	<b>2</b>	14	38	26	16,971	<b>2</b>	10	30	20	14,14
<b>Bambata</b>	19	<b>3</b>	36	46	40,667	5,03322	<b>5</b>	11	33	18,3	8,4971	<b>5</b>	9	25	13,7	6,477
<b>Bambata</b>	21	<b>2</b>	28,8	31,5	30,15	1,90919	<b>3</b>	10,5	16	13,1667	2,7538	<b>3</b>	7	11	9,333	2,082

**Table 13:** Dimensional ranges of the unmodified crystals.

The width of the crystal prism facets was also recorded on the unmodified crystals so as to help understand the morphology of the crystals and also to see if there was any pattern in the provisioning strategies of the PMG inhabitants in selecting the crystal quartz. The results show that there was no constant size for the prisms facets on the crystals that were selected; there was variation throughout the sequence.

There is also notable variability in the morphology of the pyramid, in terms of the positioning of the pyramid. In some instances, the pyramid is centred in the growth axis of the crystal, but at times it is off-centred. The results show the variation of the pyramid location on the prism per layer (See Table14).

Phase	Layer	Centred	Off-centred	None
Amadzimba	3	28.6	57.1	14.3
Pomongwe	9	0	100	0
Maleme	10	33.3	33.3	33.3
Maleme	11	32.8	44.8	22.4
Maleme	12	23.5	55.9	20.6
Bambata	13	27.8	50	22.2
Bambata	14	27.3	63.6	9.1
Bambata	15	37.5	12.5	50
Bambata	16	25	75	0
Bambata	17	0	100	0
Bambata	19	0	40	60
Bambata	21	0	33.3	66.7

**Table 14:** *Pyramid Morphology results per layer.*

As mentioned earlier the unmodified crystals were divided into two categories, i.e. the raw and used crystals. Of the total unmodified crystals, 42.8% (n=65) was used and had evidence of post-collect scarring. The scars were found on different parts of the crystals such as the tip, the edges as well as on both the tips and edges (the nature of the scars is discussed below). A total of 36.92% (n=24) had scars on the tip, 16.92% (n=11) on the edges and 46.15% (n=30) on both the tip and edges (See Figure 19).

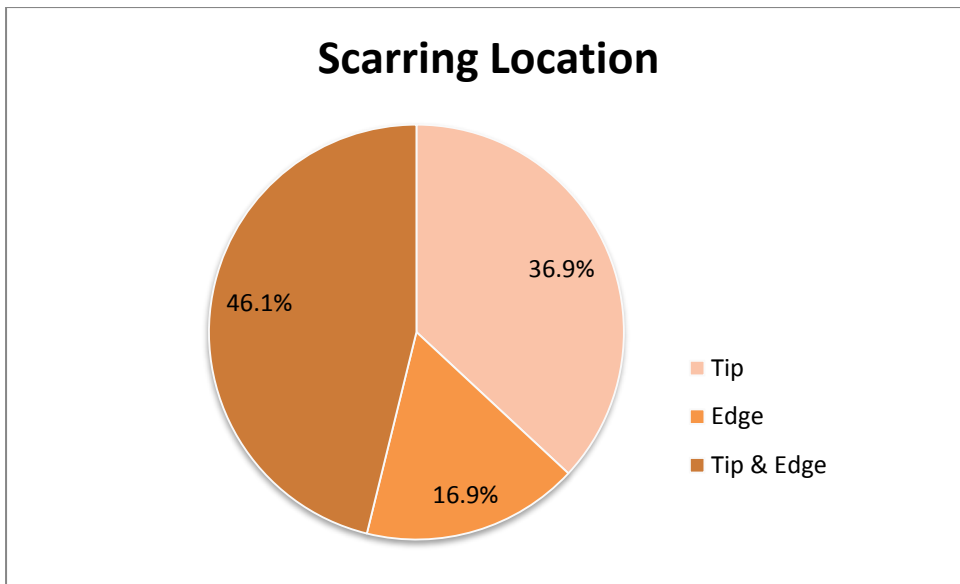

**Figure 19:** Showing the percentage of each scarring location.

The location of the scars differed with each layer, in the lower layers the scars were mostly on the tips but around layers 14-11 the scars were mostly found on both the tips and the edges and in layer 3 there were more on the tip than the tip and edges (See Table 15).

Phase	Layer	Location			Total
		Tip	Edge	Tip & Edge	
Amadzimba	3	2	0	1	3
Pomongwe	10	0	1	0	1
Maleme	11	11	2	12	25
Maleme	12	3	4	8	15
Maleme	13	1	0	6	7
Bambata	14	1	2	2	5
Bambata	15	2	0	0	2
Bambata	16	1	1	0	2
Bambata	17	1	0	0	1
Bambata	19	1	1	1	3
Bambata	21	1	0	0	1
Bambata	Total	24	11	30	65

**Table 15:** Showing the results of the location of scars per layer.

The results of the study show that the use-related scars on the ‘used unmodified’ crystals had varying patterns. The patterns of the scars ranged from single removals, multi-removals, unifacial scarring, bifacial scarring and rounding. Figure 20 below show the patterns of the scars per each layer. The results show that unifacial scarring was dominant from layer 14 onwards.

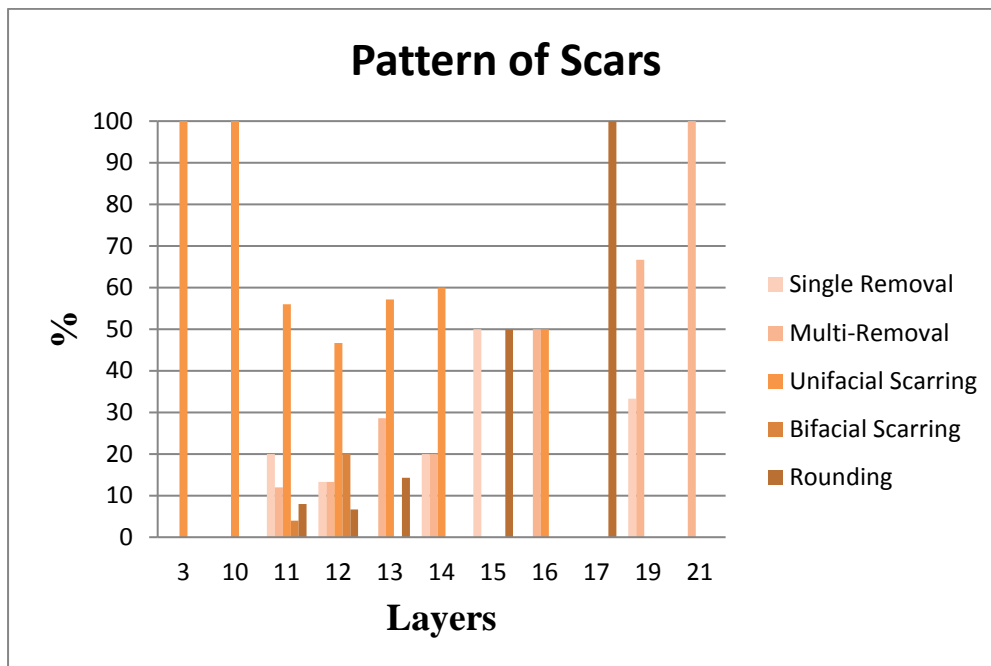

**Figure 20:** Results of the patterns of scars per layer (65 pieces were considered in total throughout the sequence).

## **5.6. Modified crystals**

The modified crystals recovered were subdivided on technological basis into 2 main categories, i.e. cores n=151 (89.34 %) and tools n=18 (10.65 %) (Blanks are not included as modified crystals as they are discussed separately) (See Figure 21). Cores were the most dominate of all the modified crystal pieces, this might imply that the intention of the PMG inhabitants, was to produce more blanks with the material rather than just shape it and use the crystals as tools. Tools (these are tools from the reshaping of complete crystal quartz) were also present in the collection but in very low quantities throughout the sequence.

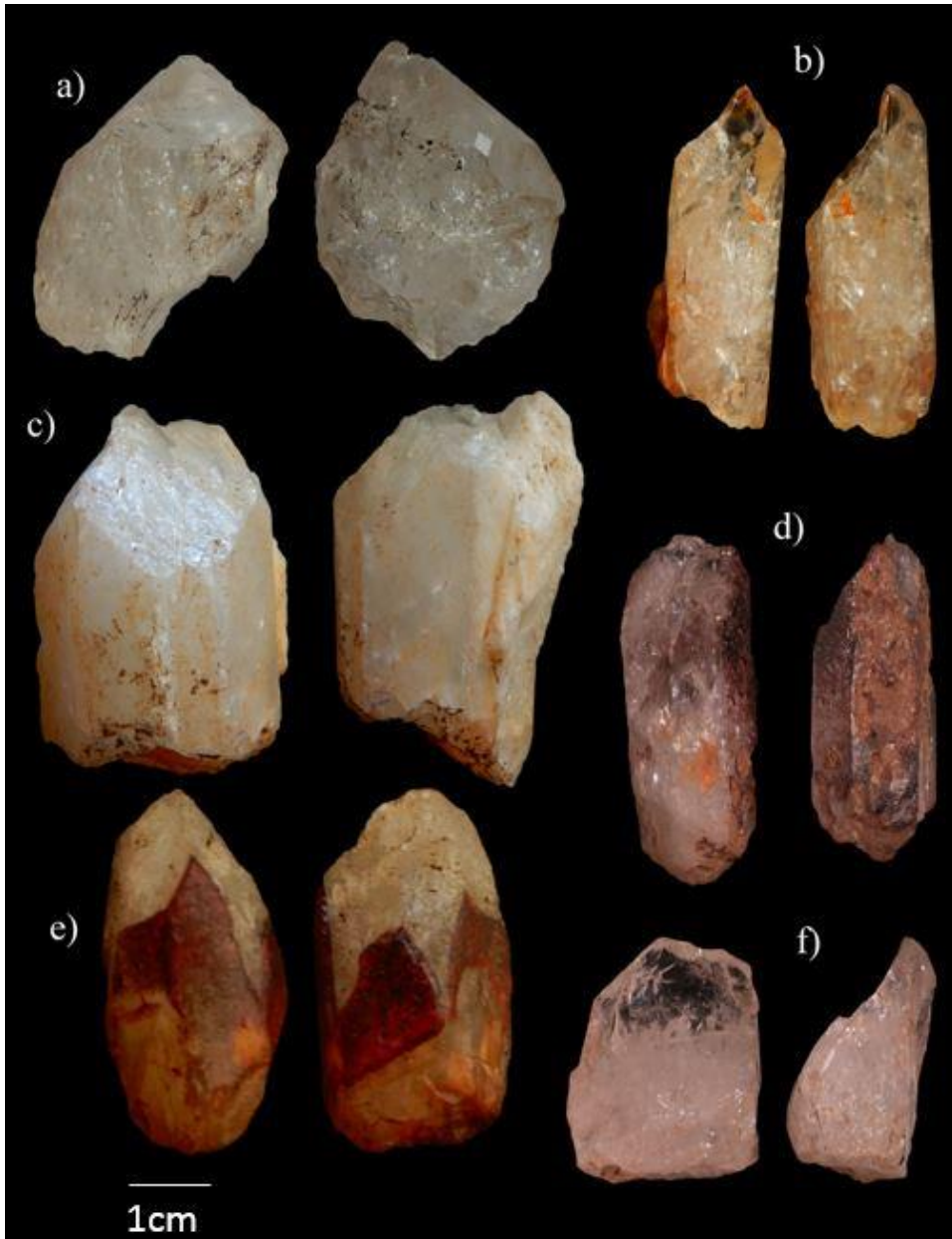

**Figure 21:** Modified crystals from different layers, i.e. a) layer 3, N° 31; b) layer 10, N° 41; c) layer 22, N° 301; d) layer 3, N°49; e) layer 11, N° 68 and layer 3, N°11.

The distribution of the cores and tools varied throughout the sequence (See Figure 22). Most of the cores were recovered from layers 3, 11 and 12. This might be because of the higher quantities of the crystal quartz in these layers; this however also shows the importance of crystals in lithic production at PMG during these periods of occupation. To note, there are layers where cores were not represented at all, i.e. layers 5, 8, 9, 15 and 19.

The tools on the other hand were also mostly present in layers 3, 11 and 12. Layer 3 had the highest number of tools recovered (n=5) followed by layer 11 and 12 with (n=4) tools each.

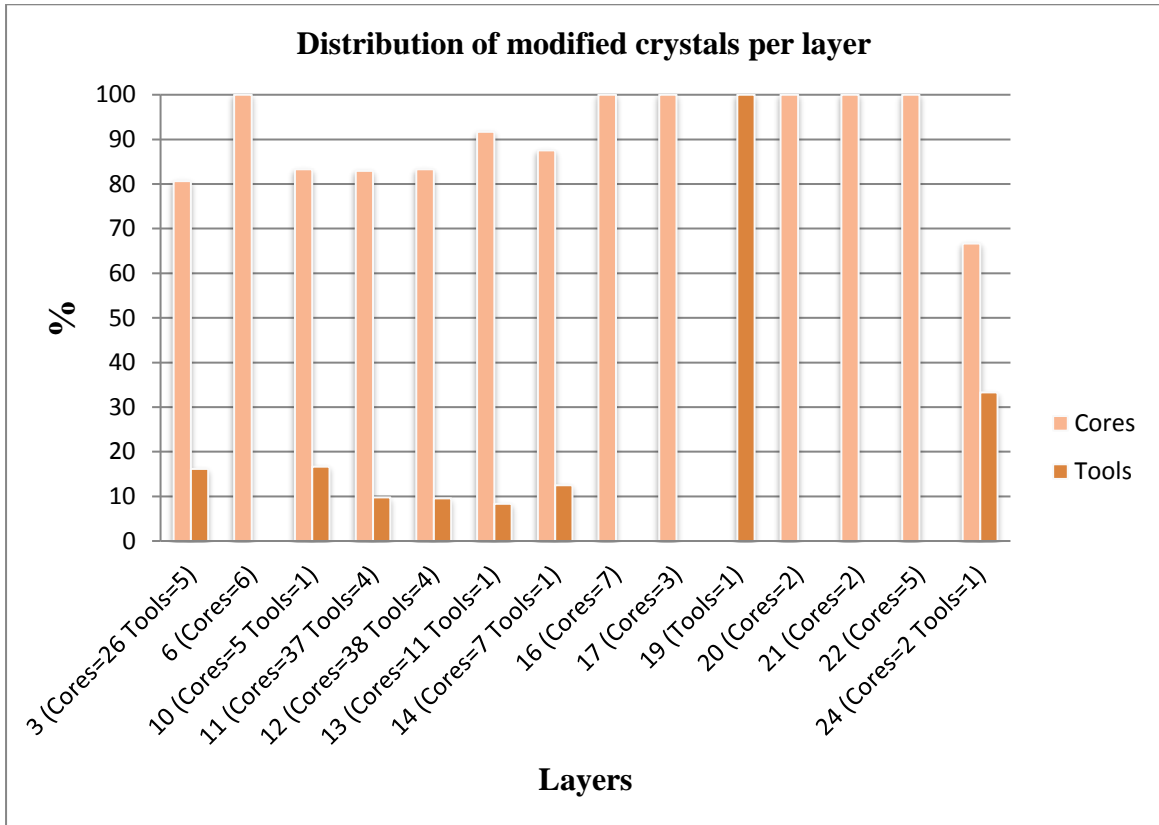

**Figure 22:** Frequencies of the modified crystals per category per layer.

### **5.6.2. Cores**

The main proportion of the recovered cores in layer 3 shows that the cores were exploited to produce microlithic blanks. The production was oriented towards the production of bladelet and micro-flakes. The bipolar knapping was paramount in the production of the bladelets. The length range of the cores in this 'Amadzimba' layer was between 12-30mm; the width was between 12 -24mm and thickness between 7-20mm (Table 16). The cores were exploited mainly from the pyramid. There were a few cores which were also exploited from the base and they followed the same principles as those knapped from the pyramid. These cores in layer 3 were discarded during the exploitation of the prism.

A few cores was also recovered from layer 6, these cores were also oriented towards the production of microlithic bladelets. All the recovered cores showed evidence of bipolar knapping (n=6). The length range of the cores in this 'Nswatugi' layer was between 13-55mm, width was between 11-31mm and thickness between 7-22mm. The crystals were opened from the pyramid, however some of the recovered crystals show that some crystals were knapped parallel to the growth axis of the crystal. The knapping of the crystals parallel to the axis of the crystals aimed at producing thin-elongated blanks in this layer. No cores were recovered from the two 'Pomongwe' layers, i.e. layer 8 and 9.

From layers 10-12, there was a high frequency of the cores recovered. The main proportion of the recovered cores was also oriented towards the production of microlithic blanks (bladelets and micro-flakes). The cores were largely asymmetric and mostly bipolar. A few of the cores showed evidence of platform preparation. The cores were mostly exploited from the pyramid. The length range of the cores recovered from these 'Maleme' layers was between 11-49mm, width between 6-30mm and thickness between 5-24mm. The exploitation of the cores was also mainly from the pyramid going towards the base of the crystals.

The 'Bambata' MSA layers 13-21 show that the main proportion of the cores was oriented towards the production of elongated flakes and a few blades. The cores had negative scars which showed the removal of elongated blanks. The cores also showed that the blanks were largely removed in the unidirectional way. The exploitation of the cores started from the pyramid and continued into the prism of the crystals. Bipolar cores are also evident during this phase. The length range of the cores was between 15-50mm; width was between 9-40mm and thickness between 7-26mm.

From layer 22-24, the cores show that the exploitation was oriented towards the production of large blanks, mostly flakes. The negative scars on the cores show that the cores were knapped mostly in a unidirectional way. The core are all bipolar cores (n=8) and this can be explained because of the properties of the raw material. The core ranged between 21-64mm in length; 8-31mm in width and 7-26mm in thickness.

### **5.6.3. Tools**

Crystals with purported functional traces were observed on the assemblage. The proportions of these 'tools' were very low, they were mainly found in layers 3 (n=5), 11 (n=4); 12 (n=4) and one each in layers 10, 13, 14, 19 and 24. These 'tools' were characterised by functional scars on the proximal edges. The so-called 'tools' appeared in a chisel-like form, presumably used for grooving or cutting hard material because of the pattern of the functional scars. The tools were mainly formed from the pyramid after the removal of the pyramid to shape and sharpen the required edge. There is one exception from layer 3, where the shaping of the tool was from the base of the crystal. The morphology of these 'tools' was the same throughout the sequence, implying they had the same kind of function during the different chrono-cultural phases. The dimensions of the 'tools' ranged between 21-52mm for the length; width between 9-24mm and thickness between 5-20mm.

Phase	Layer	Number	LENGTH				WIDTH				THICKNESS			
			MIN	MAX	MEAN	STDEV	MIN	MAX	MEAN	STDEV	MIN	MAX	MEAN	STDEV
<b>Amadzimba</b>	3	31	12	30	22,71	4,70598	9	24	16,71	3,77883	7	20	12,839	3,4068
<b>Nswatugi</b>	6	6	13	55	26,5	14,9231	11	31	16,167	7,46771	7	22	11,333	5,3541
<b>Maleme</b>	10	6	17	33	24,5	6,2849	10	22	15,833	4,02078	6	16	10,833	3,8687
<b>Maleme</b>	11	41	11	49	28,244	7,90184	7	22	15,833	4,02078	6	16	10,833	3,8687
<b>Maleme</b>	12	42	16	52	29,357	8,73128	6	32	17,341	6,09758	5	19	14,333	3,1411
<b>Bambata</b>	13	12	16	47	30,833	9,44682	10	25	18,5	5,94673	8	24	14,667	5,0513
<b>Bambata</b>	14	8	22	49	35,125	9,67231	9	31	18,625	7,96308	7	20	14,375	5,1807
<b>Bambata</b>	16	7	27	43	34,714	5,79409	13	31	22	6,65833	7	25	16,429	7,4578
<b>Bambata</b>	17	3	38	49	43	5,56776	20	29	24,333	4,50925	14	25	19,667	5,5076
<b>Bambata</b>	19	1	48	48	48		15	15	15		12	12	12	
<b>Bambata</b>	20	2	32	40	36	5,65685	25	32	32	4,94975	20	21	20,5	0,7071
<b>Bambata</b>	21	2	25	50	37,5	17,6777	23	31	27	5,65685	16	16	16	6,364
<b>Bembesi</b>	22	5	21	64	36,6	16,8018	13	31	28,5	3,53553	20	20	20	6,4962
<b>Bembesi</b>	24	3	26	44	34,333	9,07377	8	15	11	3,60555	7	11	9	2,8284

**Table 16:** *Modified crystals dimensions.*

#### **5.6.4. Technique**

The study also looked at the techniques which were employed in the exploitation of the crystal quartz. The results of the analysis show that there were two main techniques which were employed at PMG, i.e. direct free-hand knapping n= 51 (30.2%) and bipolar knapping n=118 (69.8%) on all the categories of the modified crystals. Table 17 presents the results of the techniques per layer, per each category of the modified crystals.

	<b>Direct</b>		<b>Bipolar</b>	
<b>Layer</b>	<b>Cores</b>	<b>Tools</b>	<b>Cores</b>	<b>Tools</b>
<b>3</b>	6	1	20	4
<b>6</b>	0	0	6	0
<b>10</b>	2	1	3	0
<b>11</b>	11	3	26	1
<b>12</b>	13	1	25	3
<b>13</b>	5	0	6	1
<b>14</b>	4	0	3	1
<b>16</b>	2	0	5	0
<b>17</b>	1	0	2	0
<b>19</b>	0	0	0	1
<b>20</b>	0	0	2	0
<b>21</b>	1	0	1	0
<b>22</b>	0	0	5	0
<b>24</b>	0	0	2	1
<b>TOTAL</b>	42	6	102	12

**Table 17:** *Frequencies of the techniques per layer.*

For the cores, 42 pieces (29.2%) were knapped directly while 102 pieces (70.8%) was knapped using the bipolar technique. In the tools category, n=6 tools (33.3% were knapped using direct free-hand and 12 pieces (66.7%) was knapped using the bipolar technique.

### **5.7. Blanks**

Results of the classification show that 257 (44.5%) crystal quartz pieces recovered for the study were blanks (See Figure 23). These blanks were further classified into technological categories, i.e. flakes, n=113 (44%); blades, n=7 (2.7%); bladelets, n=15 (5.8%); micro-flakes, n=26 (10.1%) and lastly fragments n=96 (37.3%), (See Figure 24). Flakes constituted the highest quantity of all the blanks.

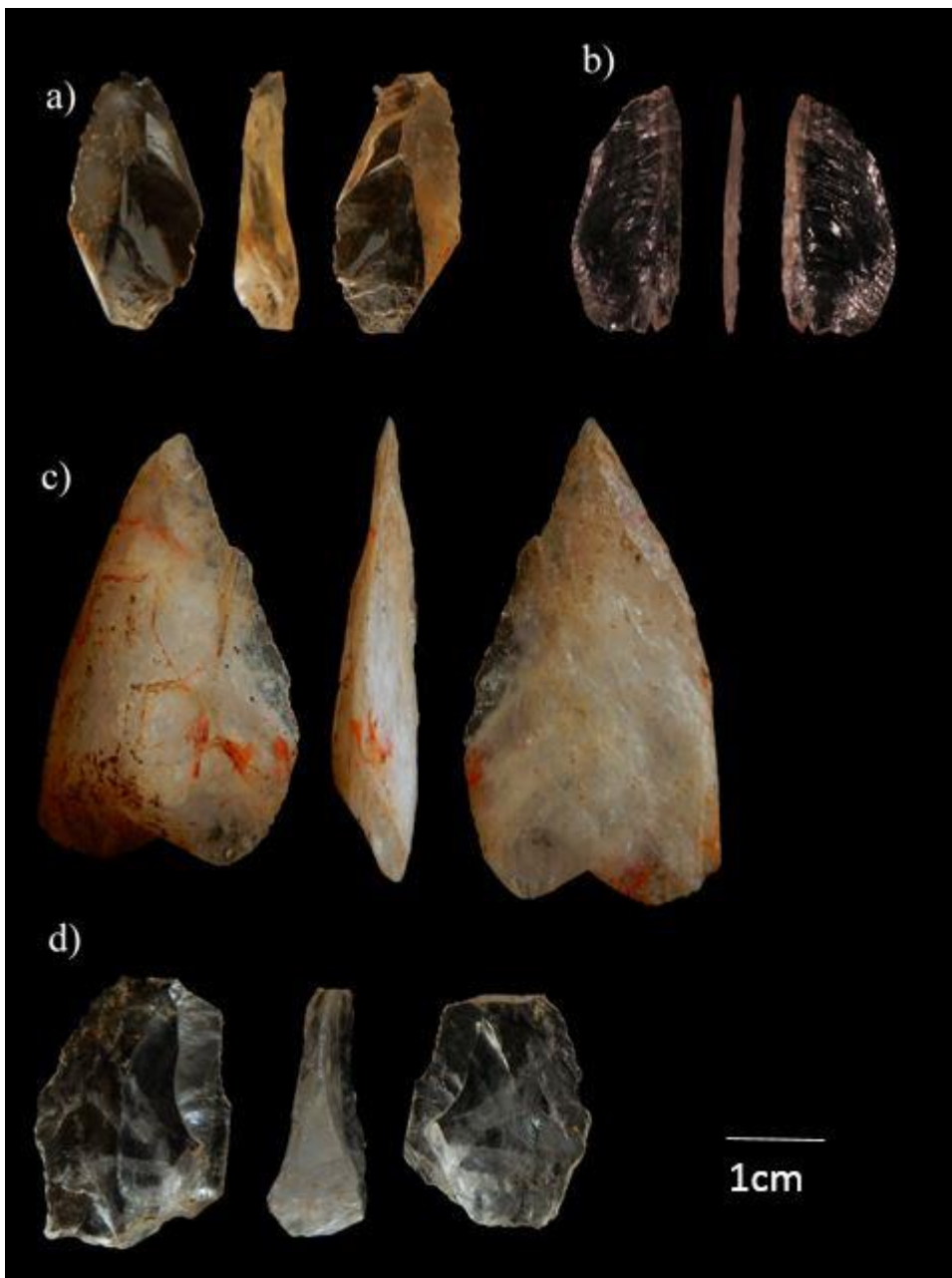

**Figure 23:** Blanks recovered from the various layers, i.e. a) from layer 3, N° 17; b) layer 22, N° 300; c) layer 24, N° 308 and d) layer 4-6, N° 15.

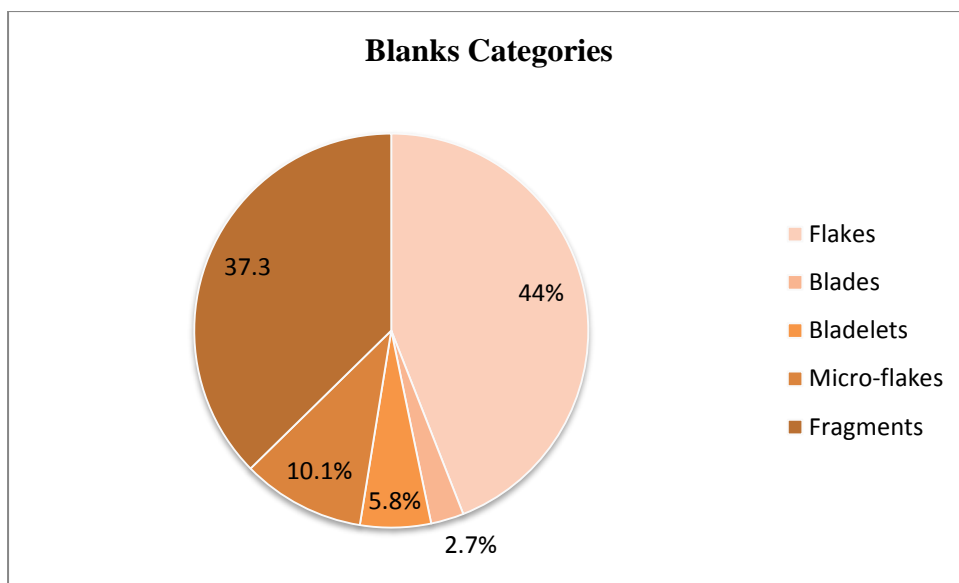

**Figure 24:** *Showing the frequencies of each blank category.*

The layers comprised of a fairly high proportion of blanks as compared to cores and unmodified crystals, however the most frequent blanks were fragments. The assemblage demonstrates that there was a large emphasis of production of flakes throughout the sequence, apart from layer 3 which was mainly oriented towards the production of micro-flakes. This observation gives a paradigm shift from the observations on the cores which emphasized technologies oriented towards the production of microlithic blanks and especially bladelets and flakes only at the deep sounding of the sequence.

Blanks in layer 3 show an emphasis on the production of microlithic blanks, most of the blanks were micro-flakes (n=12). There was also a fair representation of flakes in this layer (n=5) and a few bladelets (n=3). The micro-flakes mostly had cortical dorsal surfaces. 66.67% of the micro-flakes also had cortical platforms and 33.33% was faceted. Bladelets had faceted, plane and indeterminate platforms (33.33%) respectively. The flakes showed unidirectional dorsal scars, they were no ventral scars observed.

Layer 5 had less crystal quartz pieces recovered but however, the assemblage shows that production was oriented towards flakes (n=3). Blades, bladelets and micro-flakes all appear

represented by one piece each. The flakes had plain (n=2) and dihedral (n=1) platforms. The blade had a cortical platform whilst the micro-flake had a faceted and the bladelet a plane platform. The flakes showed evidence of unidirectional dorsal scars.

Micro-flakes dominated the proportion of blanks in layer 6 (n=6), this was followed by flakes (n=5) and 2 blades, there were no bladelets recovered in this layer. The micro-flakes had (=3) 50% faceted platforms and (=3) 50% indeterminate platforms. The flakes had (n=2), 40% plain and cortical platform each and (n=1) 20% faceted platform; the recovered blades had (n=1) each for faceted and cortical platforms.

Layer 8 and 9 had very low proportions of crystals and blanks per ser. There one flake in layer 8 and one micro-flake in layer 9. The flake had a cortical platform and had evident of unidirectional dorsal scars. The micro-flake on the other hand had a cortical plain signifying that there was no preparation done on the core

From layers 10 until the end of the sequence, these layers comprise of a high frequency of blanks. The recovered material demonstrates that there was an emphasis oriented towards the production of flakes There are a few bladelets (n=5) recovered from layer 11, these had cortical (n=3) and plain platforms (n=2). The most of the flakes exhibited unidirectional dorsal scars. The flakes had length range between 20-58mm; width between 11-43mm and thickness between 4-26mm (Table 18).

Phase	Layer	LENGTH					WIDTH				THICKNESS					
		Number	MIN	MAX	MEAN	STDEV	Number	MIN	MAX	MEAN	STDEV	Number	MIN	MAX	MEAN	STDEV
<b>Amadzimba</b>	3	27	10	28	17,56	4,38824	37	5	21	11,595	3,94024	38	2	11	4,7368	2,35595
<b>Nswatugi</b>	5	7	19	30	24,286	3,54562	7	11	19	15,143	2,47848	7	3	10	6,5714	2,43975
<b>Nswatugi</b>	6	17	12	32	21,235	6,69449	18	7	24	13,444	5,23812	20	2	5	3,4286	2,15883
<b>Pomongwe</b>	8	1	27	27	27		1	25	25	25		1	8	8	8	
<b>Pomongwe</b>	9	1	17	17	17		1	7	7	7		1	3	3	3	
<b>Maleme</b>	10	9	11	33	21,889	7,27056	11	8	28	16	6,08276	11	4	4	6,2727	2,4532
<b>Maleme</b>	11	51	12	58	27,118	9,83798	62	6	43	27	8,1312	66	3	23	9,1818	3,4636
<b>Maleme</b>	12	30	12	49	29,967	7,99346	34	8	35	17	6,7929	34	3	16	8	3,25669
<b>Bambata</b>	13	17	13	44	27,059	8,51081	17	8	33	22,2	8,10818	18	3	13	6,3333	3,06786
<b>Bambata</b>	14	8	27	52	36,25	7,74597	9	17	43	25,778	9,6278	9	5	26	10,556	6,40041
<b>Bambata</b>	15	1	28	28	28		2	13	21,5	17,25	6,01041	2	6	8	7	1,41421
<b>Bambata</b>	16	6	29	39	33	4,38178	7	10	37,5	21	8,79867	7	5	12	8,5	9,38786
<b>Bambata</b>	17	6	20	36	29,75	6,82459	11	11	38	24,167	7,50424	11	4	10	6,5	2,10303
<b>Bambata</b>	19	2	32	47,5	39,75	10,9602	2	2	32,5	29,25	4,59619	2	8	19	13,5	7,77817
<b>Bambata</b>	20	6	22	40	30,167	7,10399	7	15	34	21,833	7,09376	8	6	7	6,5	2,72554
<b>Bambata</b>	21	8	29	47	36,813	5,95182	9	13	34	23,944	6,25222	9	4	19	8,375	4,21307
<b>Bembesi</b>	22	10	29	53	36,9	6,64078	13	17	28	23	3,47703	13	5	13	8	2,83974

**Table 18:** *Dimensions of the blanks.*

#### **5.7.4. Platform Analysis**

The striking platforms on the blanks were also a major focus of this study as they help understand the exploitation strategies employed on the crystal quartz. The results of the study have shown that there was variation in the platform types on the blanks throughout the PMG sequence. Most of the blanks had cortical n=74 (28.8%) and indeterminate n=72 (28.1%) platforms. Facetted platforms were represented by n=54 (21%) of the total blanks; plain at n=44 (18.3%) and lastly dihedral at n=12 (4.7%) (See Figure 25). The distribution of each platform type per layer is presented in Figure 26.

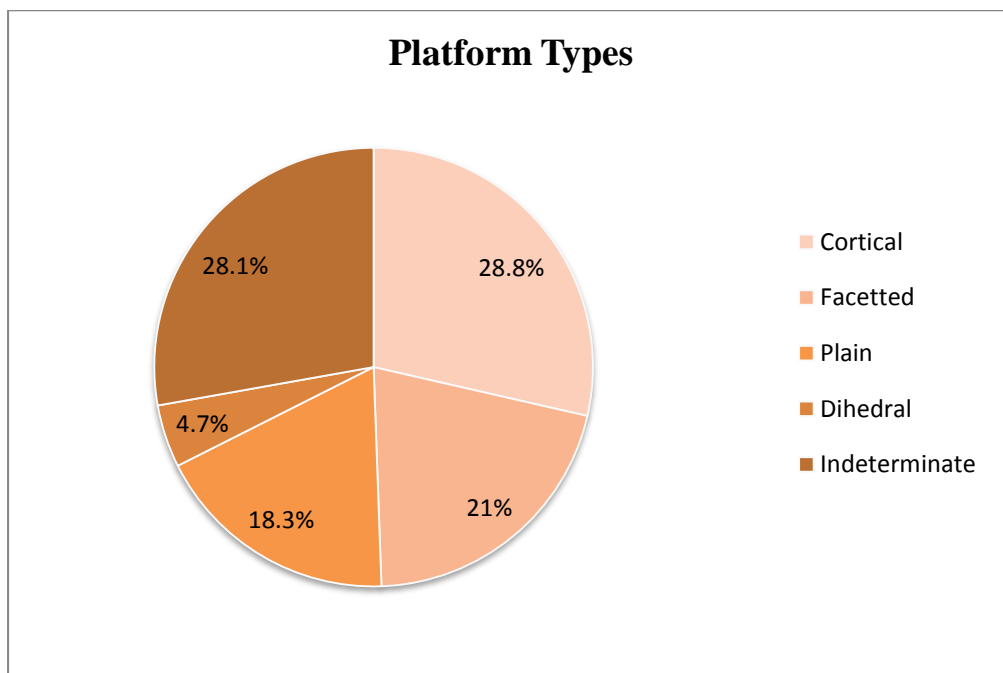

**Figure 25:** Platform types frequencies.

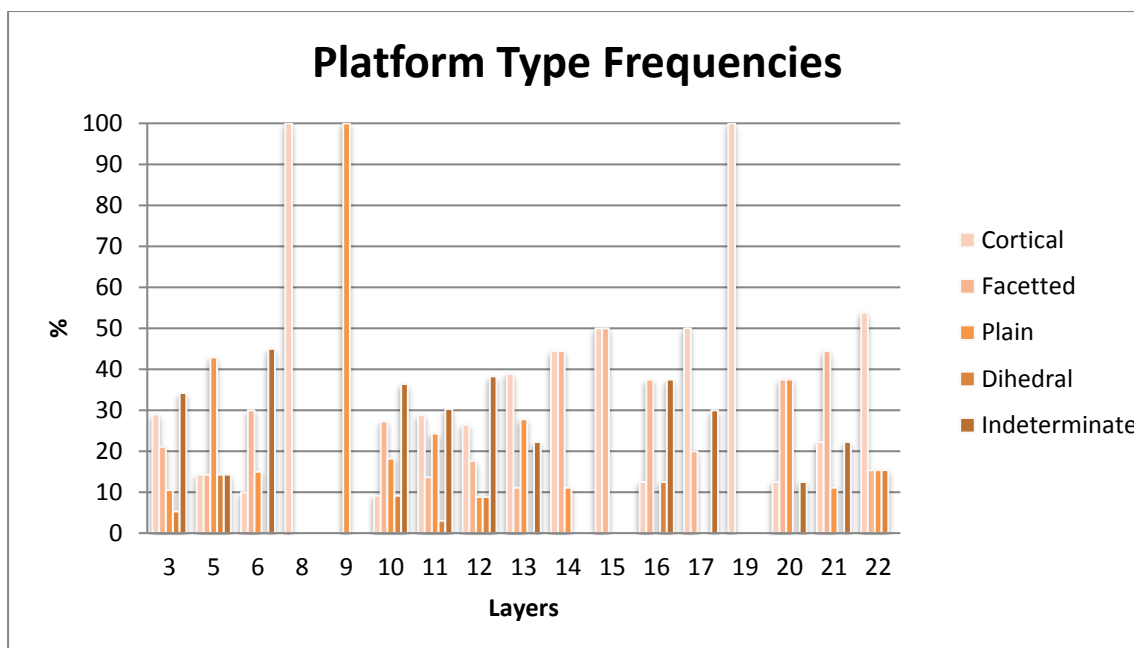

**Figure 26:** Platform type frequency per layer on all the blanks (n=257).

### **5.7.5. Platform Dimensions**

The dimensions of the platforms were also measured in this study. The results from the platform dimensions show that there was variation in the sizes of the platforms on all the categories of the blanks throughout the sequence. The maximum length and width of the platform were measured on all the blanks which had complete platforms, i.e. n=183 (71.6%) blanks were recorded.

Results show that on the flakes, the length range was 6-27mm and width 1-15mm; for the blades it was 5-19mm length and 2-10mm width; micro-flakes had 3-13mm length and 1-5mm width; the micro-blades had length range of 2-11mm and width 1-5mm and lastly the fragments were the integrity was 1 or 12 and the platform complete, the length range was 3-26mm and width 1-9mm.

### **5.7.6. Technique**

The study looked at the techniques which were employed in the exploitation of the crystal quartz throughout the sequence. Results show that two main techniques were used in knapping the crystals, i.e. direct free-hand n=133 pieces (52%), bipolar n=50 pieces (19%); however there was another set of indeterminate n=74 (29%) which was recorded (See Figure 27). Figure 28 shows the results of the techniques per layer.

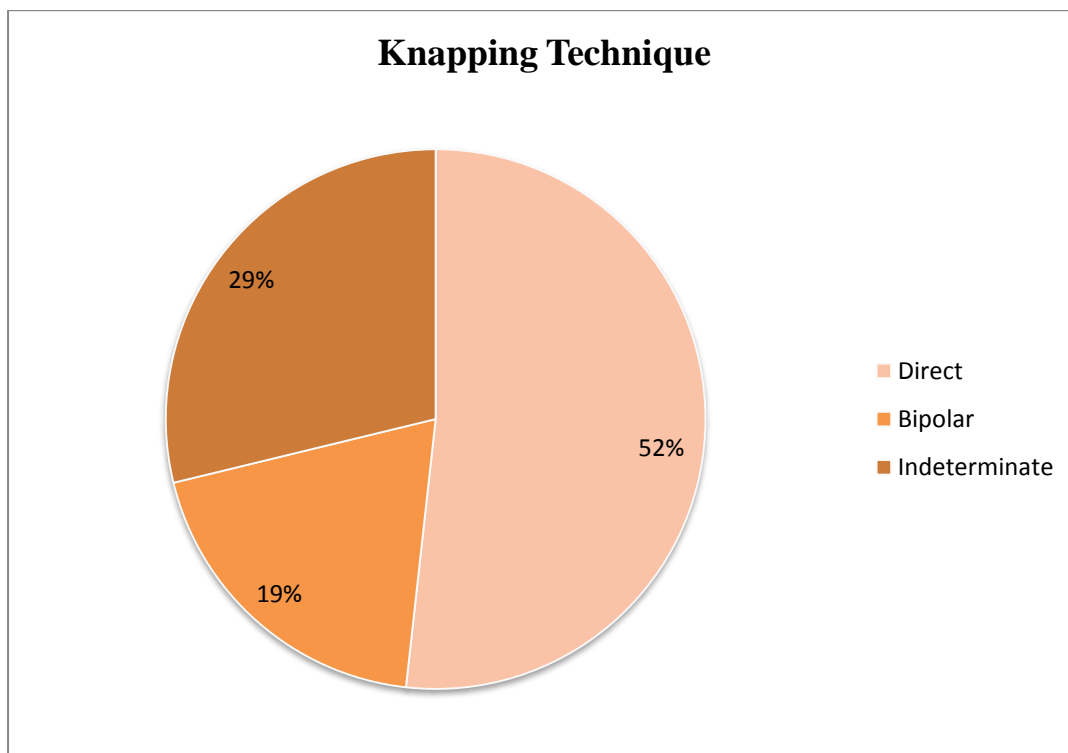

**Figure 27:** *Techniques employed on the blanks.*

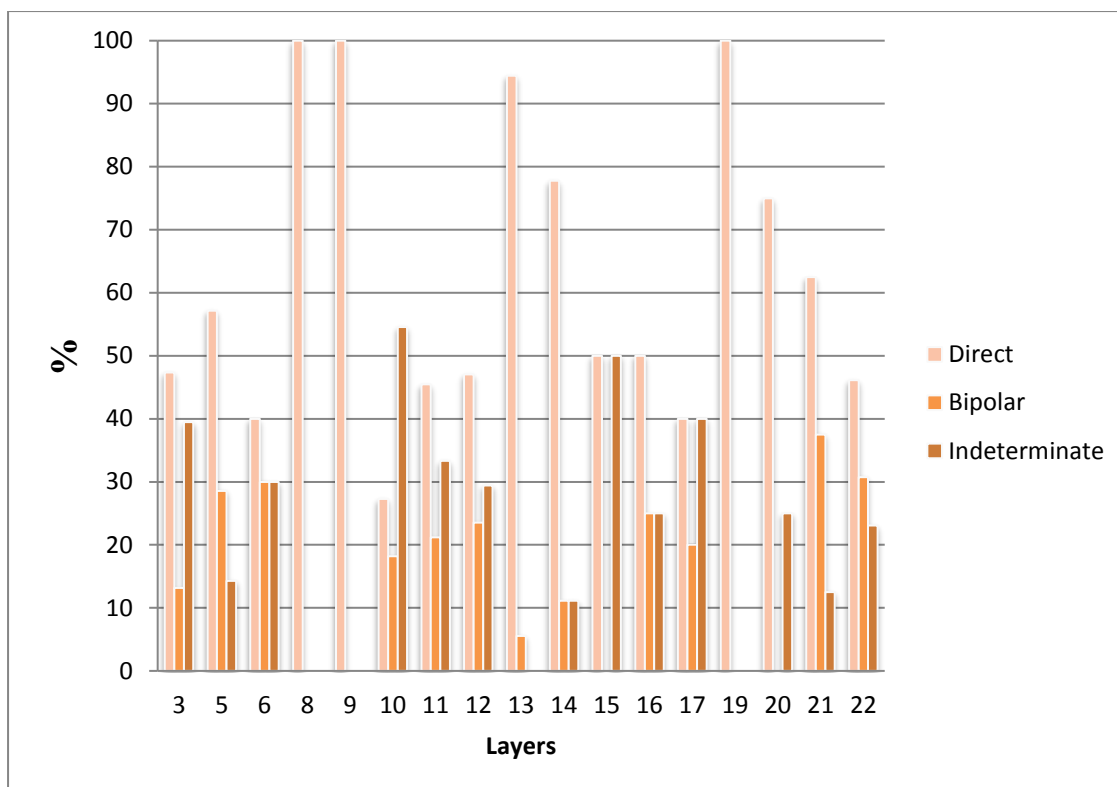

**Figure 28:** *Percentage of each knapping technique per layer.*

The direct free-hand technique was the most dominant to be observed on the blanks of all categories. In the fragments category however, most of the pieces were indeterminate in terms of the technique because they had other parts of the blank broken such as the platform or the distal parts which help determine the technique of exploitation.

### **5.7.7. Functional Scars**

The study also looked at the blanks to see if they had been used for certain activities, this was determined through looking for evidence of possible functional traces on the blanks. The results show the functional scars were observed on some flakes n=35 (30%); blades n=2 (28.6%) and on a few micro-blades n=2 (13.3%). The functional scars were mainly on the elongated blanks. These functional scars occur randomly throughout the sequence on these blanks.

## **5.8. Reduction Strategies.**

The major aim of this study was to understand the crystal quartz technology at PMG, how the crystals were exploited. The analysis of the cores and blanks, managed to identify the main reduction strategies which were employed during the exploitation of crystal quartz at PMG during the MSA and LSA. The cores suggest that there was specific laminar reduction strategy, with the production of bladelets being paramount from layers 3-12 and elongated blanks from layers 13-21. The blanks however suggest that throughout the sequence except in layer 3, the production was oriented towards the production of mostly flakes; the other blank types i.e. blades, bladelets and micro-flakes were in fewer quantities. This variance can mainly be accounted for by the sampling strategies which were employed in this study since, I only considered the pieces which had the characteristics of crystal, i.e. pieces with the crystal natural surface, and this influenced the sample.

The results show that there were various stages in the reduction strategies of crystal quartz during both the MSA and LSA (Figures 13 and 14, Chapter 4 catalogues the various reduction strategies). The beginning of the reduction sequence initialised by removing the pyramidal or base '*entame*' blank. The blank was obliquely knapped from the core to form an asymmetric shape on the crystals. The exploitation however was mainly from the pyramid of the crystals throughout the sequence. The '*entame*' was characterised by having a cortical platform as well as a cortical dorsal surface. The knappers used the geometry of the pyramid to form their first striking platform of the '*entame*' blank. This phase was observed in all the layers at PMG during the MSA and LSA exploitations of crystal quartz though only a few cores and blanks were recovered on site with (n=28) crystals showing pyramidal opening and (n=17) showing base opening. The cores discarded at this initial stage demonstrated failed attempts to produce desired blanks due to the shattering of the crystals. This might imply that the actual opening of

the crystals was not done on site or maybe tell more about the site organisation during the MSA and LSA periods.

The reduction continued removal of another cortical blank; with a cortical dorsal part but plain butt. This strategy was observed from both the pyramid and the base of the crystal quartz. A minimal number of these cortical blanks were observed in the selected assemblage throughout the sequence. This also has implications on either the raw material provisioning strategies of the PMG inhabitants or the site organisation during these periods. The removal of this second cortical blank left only a remnant of the pyramid or base of the crystal.

The remnant of the pyramid or base was obliquely knapped off the cores to produce products with either one or both sections with the cortical surface but the dorsal and ventral surfaces had no evidence of the crystal's natural surface. Blanks and cores of this stage of reduction are not many in the assemblage implying that maybe at times the pyramid or base was completely exploited during the first two stages of reduction and the prism was all exposed.

The exploitation of the prism followed with the production of obliquely knapped products, the cores and blanks were either symmetric or asymmetric. From the analysis of the blanks and cores; this was the main reduction strategy which was observed throughout the MSA and LSA layers. It was used for the production of flakes, blades, bladelets and micro-flakes. With this reduction strategy, crystals were reduced to miniaturised size ranging between 12-30mm in length. Blanks and cores of this stage show evidence of unidirectional scars on the dorsal surface. The blanks had cortical, faceted, and dihedral platforms. The cortical facets of the crystal were used as the platform for knapping blanks with cortical platforms. Preparation of the striking platform was also done to control the angle of percussion for some blanks. The quantities of products exhibiting this reduction stage shows that most of the crystals were introduced to the site with pyramid already knapped off the prism. This imply on the

provisioning strategies of the PMG inhabitants as well as their site organisation. Cores were discarded after accidents during this phase.

Some cores and blanks also demonstrated the evidence of knapping in the growing axis of the crystals. This reduction strategy was mainly used to try and produce laminar elements along the adjoining facets of the crystals. With this strategy the crystals were knapped from both the pyramid and the base. However cores were discarded after they were failed attempts to produce the laminar elements due to the knapping accidents and also the physical properties of the crystal quartz. At most the knapped crystals showed evidence of shattering in the inside which led the knappers to discard the cores.

Broad blanks were produced through transversal knapping of the crystal prism. This reduction strategy produced blanks with cortical platforms if knapped from the crystal facet. The edge of the facets was used as the striking platform since it had already an angle suitable for percussion. Blanks and cores which demonstrate this strategy; are not many throughout the sequence and the produced blanks have a relatively thin section.

## **CHAPTER SIX**

### **6. Discussion**

#### **6.1. Introduction**

The chapter presents the discussion of the data presented in the previous chapter and gives a general synthesis of these results in-line with the main research questions of this study. The chapter discusses provisioning strategies of the PMG inhabitants in crystal quartz and then go on to detail the technology which was employed on this material in lithic production during the MSA and LSA.

The exploitation of crystal quartz at PMG showed little variations throughout the different chrono-cultural phases. The properties of the material might have limited the technologies of the inhabitant and they had to suite to these properties. The crystals were mainly classified into three main categories, i.e. unmodified, modified and blanks. The quantity of the unmodified crystals leads to a number of questions for instance: a) the symbolic nature of the material, b) whether the material was being kept as a reserve for posterity, c) if they we used for other purposes which traces are not visible at a macroscopic scale. In terms of lithic production, the crystals were mainly followed the flake reduction sequence in all the other layers and techno-complexes, but the Maleme suggested otherwise with a bladelet oriented technology. Crystal quartz was more generally exploited in Maleme and Amadzimba phases as compared to the other phases.

## **6.2. Sample variation**

The study has shown that there was a large quantity of crystals at PMG. PMG is one of the most significant Stone Age sites in the Matopos and Zimbabwe at large because of its sequence from the MSA through to Holocene LSA. The numbers of the crystal quartz are interesting because they are high as compared to the other sites where the material has been mentioned (Sibudu, Wonderwerk, Boomplaas, Elands Bay Cave, Sehonghong, Ntloana Tšoana).

There was notable variation in the presence of crystal quartz throughout the sequence. The material does not appear in the lower layers of the Bembesi techno-complex, i.e. layers 27-25. This absence can be explained by the fact that the inhabitants were not choosing to collect and exploit crystals in the cave as yet. Crystal quartz starts to appear in the sequence in layer 24, in very low quantities; the quantities however increased in layer 22 which marked the end of the Bembesi and the beginning of the Bambata phase at PMG. From layer 21-13, there is also notable variation in the distribution of crystal quartz between these layers. The numbers are low in the early stages of the Bambata phase but later increase towards layers 13 and 14 going into the Maleme phase. The increase of the quantities of crystals towards the Maleme might suggest the gradual change from the Bambata to Maleme techno-complex. Another alternative theory will be that there is a mix of layers at the interface between the Bambata and the Maleme, as suggested during the 2018 campaign upon re-opening the Trench I of Cooke. The Maleme phase which corresponds with layers 12-10 of Cooke, saw the massive exploitation of crystal quartz in these layers with layer 11 representing the highest number of crystal quartz throughout the sequence,  $n=165$  (28.5%) of the total sampled crystals. However, in the last layer of this phase, i.e. layer 10, the quantities of the material drastically reduced to only  $n=20$  (3.4%) and this continued into the Pomongwe phase where only 3 crystals were recovered between layers 8 and 9. The quantities increased in the layers corresponding to the Nswatugi phase, i.e. layers 6 and 5. The Amadzimba phase however had the second best representation

of crystal quartz at PMG as compared to the others layers. The variations in the distribution of crystal quartz show that the inhabitants of PMG at this time preferred crystal quartz for lithic production. Above all these variations of the quantities throughout the sequence also show that there were times when the material was more significant than others. There is temporal variation in the exploitation of crystal quartz at PMG.

### **6.3. Raw Material**

The results from the previous chapter have shown that the selection of the crystals at PMG by the inhabitants focused on crystals with different diaphaneity, i.e. transparent, semi-transparent and opaque. It also showed that some of the selected crystals had different inclusions; however a larger number of the total crystals did not have any inclusions. The inclusions are significant in determining the provenance of the crystals (Petrovic et al 2015; Morgado et al 2016), however, for this study they were just mentioned and described and not fully analysed. As such, the diaphaneity and inclusions in the crystals can help in understanding the provision strategies of the PMG hunter-gatherers. The presence and absence of inclusions on the crystals from PMG is also suggestive of the different sourcing places. As such, there is need for further study on the notable inclusions to determine the provenance of the crystals and also help better understand the provisioning strategies of the PMG inhabitants. For this to be done there is need to source and know the distribution and variability of the Matopos crystal quartz and its immediate surroundings.

## **6.4. Natural Surface**

The natural surfaces of the crystals at PMG were mostly weathered as highlighted by the results in the previous chapter, i.e.  $n=425$  (73.5%) of the total crystal quartz pieces and  $n=153$  (26.5%) for the crystals with fresh surfaces. There were notable changes however in the proportions of these crystals in layers 13 and 14 where the numbers of the fresh equal the weathered. This imply that during this time the PMG inhabitants would go collect the crystal quartz from the primary sources rather than go to the alluvial terraces.

The fact that the higher quantities of the crystals were weathered implies that the crystals were being sourced from a secondary context. This notion can be supported by the fact that there is a river which lies about a kilometre from the site (Maleme River), therefore the crystals might have been mostly been transported through the river channel which crosses a geological formation where crystal quartz occur. For the fresh crystals, it is also possible that there was another source which was within walkable distance from the site where they could source the fresh crystals and bring them to the site. However, for us to have a clear picture on the actual sources of the crystals there is need to conduct an inclusion analysis on the crystals.

## **6.5. Technical Variation**

### **6.5.1. Unmodified Crystals**

The crystals of PMG were classified into 3 technical categories, i.e. unmodified, modified and blanks. There is variation in the quantities of these categories within the layers and techno-complexes at large throughout the sequence. Unmodified crystals represent the smallest proportions of the crystals with  $n=152$  (26.3%) of the total selected crystals. The notable small quantities of the unmodified crystals as compared to the other categories imply that the collected crystals were highly considered for lithic production and exploitation. This is significant to our understanding of crystal quartz exploitation as it is a norm that researchers mention raw crystal quartz at various sites (Cooke 1963 at PMG).

The quantities of the raw crystals were higher than those of the unmodified used crystals. Which leads to question why they were collected if not exploitation? This can however be answered by supposing that they might have been collected for another reason which might be symbolic since the material has been found in correlation with shamanistic tendencies and is associated with sacredness and spiritual powers from the ethnographic literature (Eliade 1972; DuBois 2009; Pargeter & Hampson 2019). The same pattern has also been described on ochre remains, whereby raw ochre fragments are often found in MSA and LSA sequences. This appearance of unmodified crystals might shed more light in the provisioning strategies of the PMG inhabitants, as the material is easy to transport because of its small size as compared to blocks of other raw materials.

The data for the study show that there was also disparity in the sizes of the unmodified crystals. Size ranges according to length were categorised in classes of (15-30mm), (31-45mm), (46-60mm) and larger than 60mm. The crystal sizes varied between these ranges which imply that there might have been no preference in the sizes when collecting the crystals or maybe the larger ones were mainly exploited in lithic production. This trend was observed in all the techno-complexes throughout the MSA and LSA sequence. The sizes of the modified and blanks will help shed more light on this observation.

The analysis of the unmodified crystals from PMG also indicated that there is a degree of variation in the morphology of the crystals. This was determined by looking at the size of the prism facets, the number of pyramidal facets on each crystal as well as the position of the pyramid. Results showed that the crystal morphology varied from each crystal as there was no standard facet size for crystals for a certain size. The number of pyramidal facets also varied from piece to piece from 3-7 facets, this did not also determine the position of the pyramid itself. The pyramids were either centred or off-centred. The varying morphologies of the

selected crystals at PMG imply that there was no preference to certain morphology when collecting the crystals.

### **6.5.2. Modified Crystals**

Data for the study show that n=196 (29.2%) of the total crystal selected were modified (this figure does not include blanks as they are discussed separately). These modified crystals were subdivided into two classes, i.e. cores, and tools. The assemblage for the study shows that there were differences in the quantities of each class per layer throughout the sequence.

The assemblage of the study shows that there were differences in the quantities of the modified crystals per layer throughout the MSA and LSA PMG sequence. The bottom layer of the sequence, i.e. Bembesi saw with no representation of modified crystals at all (27-25), the absence of the crystals in these layers has been explained beforehand. However, modified crystals start to appear in layer 24. The quantities of the modified crystals in this layer were very low; the same can be said for layer 22, though it had better representation than the former. These quantities can be attributed to the activities which were taking place at PMG during the Bembesi phase.

From layer 21-13 (Bambata) there is notable variation in the representation of the modified crystals. In the first layers preceding the Bembesi, the quantities are very low until layer 16. This somewhat marked the change in the presence of crystal quartz at PMG. The following layer however had no modified crystals present and this might be as a result of the variability in site activities. Layers 13 and 14 also saw a continued increase in the quantities of modified crystals. These layers marked the interface between the Bambata and Maleme phases.

The Pomongwe phase (9-8) had no modified crystals at all and this can be attributed to the change in site activities during that time. Layer 6 and 5 (Nswatugi) had notable variation as well, as there were a few modified crystals in layer 6 but none in layer 5. this variation within

the same phase can imply that the site activities changed going to the end of the Nswatugi. However, layer 3 representing the Amadzimba had a sizeable amount of modified crystals, the rapid increase in the quantities clearly show the change in the site activities as well and development in time at PMG. A lot was going on during the Amadzimba phase with regard to crystal quartz exploitation at PMG.

The results of the study show that there was variation on the types of cores recovered of the sample. The study shows that there was the proliferation of bipolar cores, blade/bladelet cores and flake cores. There was super positioning between the bipolar and the bladelet cores, as a large percentage of the blade/bladelet cores were also produced using the bipolar technique.

The results have shown that there was size variation amongst the modified crystals at PMG. The crystals were classified in length ranges, with the smallest range being 11-20mm and the largest modified crystal being 61-65mm. the majority of the cores ranged between the 21-50mm ranges, there are a few pieces which went beyond 50mm up to 64mm; the same for the small ones which went up to 11mm. The variations in the sizes of the cores show that the crystals were being reduced in a standard manner but not to exceedingly very small size. This implies that the PMG inhabitants had a well-structured provisioning strategy for procuring crystal quartz. The data from the study show that the technology on the modified crystals saw the production of mainly flakes and laminar elements. There was variation on the reduction sequences and the stages of discard of the modified crystals. For the cores, the majority of them were opened from the pyramid and were reduced and discarded mostly during the exploitation of the prism or toward the base due to knapping accidents. This was also the case with the tools. They were also aware of the best knapping axis of the material as the technologies show that they either knapped it obliquely or vertically, which is the best axis's to break a crystal.

The analysis of the modified crystals at PMG also shows that there was variation in the techniques employed to exploit the crystals. Direct free-hand and bipolar were observed as the main techniques of reduction on the crystals. The bipolar technique was the most prominent throughout the sequence. This technique might have been employed to suit the structure and size of the crystals, since quartz is a hard material and has specific knapping techniques.

### **6.5.3. Blanks**

Results from the study show that the majority of the crystal quartz pieces recovered at PMG were blanks  $n=257$  (44.5%). The blanks were distributed throughout the sequence in variation in quantities. The majority of the blanks come from the layers which had large number of crystals, i.e. layer 3 ( $n=38$ ), 11 ( $n=66$ ) and 12 ( $n=34$ ).

The blanks were further technically classified into 5 main classes, i.e. flakes  $n=113$  (44%), blades  $n=7$  (2.7%), bladelets  $n=15$  (5.8%), micro-flakes  $n=26$  (10.1%) and fragments  $n=96$  (37.4%). These classes show that the exploitation of crystal quartz at PMG was mainly focused on the production of flakes. The flakes are represented in almost every layer of the sequence besides layers 9 and 24. In layer 9 the absence of flakes can be explained by the low numbers of crystals however in layer 24, the absence raises questions as there are cores which were recovered from this layer. The distribution of the blades however is not vibrant; they are found mainly in layers 5 and 6 and then spaced between 12, 17 and 21. For the bladelets, the distribution is almost the same being vibrant in layers 3, 11 and 13. There is a notable observation with the blades/bladelets; the quantities of these categories do not seem to tally with the quantities of blade/bladelet cores which were recovered at the site. The micro-flakes distribution, tally with the time periods in which micro-lithic products were being produced. The micro-flakes were recovered from layer 13 and are in larger quantities from layer 6 to 3. These layers correspond with time period when microlithic pieces were being produced.

The data from the study indicated that there was size variation on the blanks. Most of the flakes were in the 31-40mm range, followed by 21-30mm, 41-50mm and 51-60mm. The variations in the sizes show that at the top layers, i.e. 6-3, the production was focused on small elements. On the blades, two ranges were formed, i.e. 31-40mm and 41-50mm, most of the blades were between 31-40mm and these were the ones in the upper layers. The bladelets were between 15-20mm, 21-25mm and 26-30mm and the majority were in the 15-20mm range. For the micro-flakes, the sizes varied between 12-19mm in length and the size of the fragments also varied. The variations in the sizes of the blanks show that the PMG inhabitants changed through time in their exploitation of the crystal quartz, as they produced large blanks in the early stages of the site occupation and this changes with time to produce small blanks in the later phases.

The crystals were opened mainly from the pyramid and exploited going towards the base of the crystals. The flakes recovered were mainly products of exploitation of the crystal from the pyramid. There are a few flakes which represent the initial opening of the crystal. However, the majority of the flakes were products of the exploitation of the prism in an oblique manner. The same strategy was also employed for the production of blades/bladelets, (laminar products) so was the exploitation of the crystals parallel to the axis of growth to also produce the blades/bladelets. Most of the micro-flakes were not easy to determine where they came from on the crystals and the direction of knapping because of their small sizes.

Two main techniques of exploitation, i.e. bipolar and direct free-hand were also observed on the blanks. However the direct free-hand technique was the most dominant observed on the blanks. This does not tally with the observations on the cores, where the bipolar technique was dominant in the reduction of the crystals. This might imply that the bipolar reduction on the cores was mostly employed just before the discard of the cores. However, this discrepancy can be explained first by taking into account the structure of the crystal. The other explanation might be the sample collected for the study, in that the study collected only the crystals with

facets hence maybe the blanks with bipolar evidence were those with no facets and were not included in this study.

The analysis of the blanks also indicated that there was some degree of variation on the types of striking platforms. A large number of the blanks had cortical platforms, this show that they were knapped on the natural surface of the crystal without any preparation. Facetted platforms were also dominant and this shows that there was a degree of preparation on the blanks. This is also supported by evidence of overhang preparation on most of the facetted platforms. The platform sizes as presented from the data also had variations. They varied from within the blank categories.

## **6.6. Functional variation**

The data from the study have shown that there was evidence of possible functional traces on some of the crystals from the unmodified crystals to the blanks. The study for functional traces was beyond this study however, there is need to highlight and then be developed in future research.

Results show that this category had evidence of suggestive functional traces. The nature and position of the scars varied, some were on the tip, others on the edges of the facets but a large percentage had the scars on both the tip and the edges. It is however not possible to say with any degree of confidence what these unmodified crystals were used for. But just from considering the structure of the material and the nature of the scars, they might have been used to curve or inscribe on some material or maybe there were simply used for symbolic purposes. This however, needs to be tested with proper experimental procedures.

The PMG inhabitants in their exploitation of the crystal quartz preferred producing blanks than tools. This is shown by the fact that the quantities of the modified crystal tools' are very low throughout the sequence. A large proportion of the tools come from layer 3 and then layers 11

and 12. The analyses of the modified crystals ‘tools’ have shown that they were in the form of chisel-like tools. The nature of these ‘tools’ imply that they might have been used as grooving implements or for cutting hard material because of their sharp edges. Formal tools were very limited throughout the MSA and LSA PMG sequence. Only 6 retouched pieces being identified throughout the whole sequence with n=3 coming from layer 6 and one each from layers 10, 11 and 14. All the formal tools appeared in scrapper form, with the retouch on the elongated parts of the pieces. Suggestive possible functional scars were however observed on mostly all the categories of the blanks. The nature of the scars imply that some of the blanks were ‘utilised tools’ and not formal tools, either for scrapping on hard and soft material or cutting. The use of these blanks as tools shows how important they were in the daily lives of the inhabitants and also points to the good properties of the material, that it can be used for certain activities without need to retouch it. This observation also entails that a typological study alone, focusing on the retouched tools alone will not be sufficient in inferring the use of the stone tools since the material can be used without formal retouching.

### **6.7. Techno-economic Approach.**

The analysis of the cores and blanks from PMG implies that the PMG inhabitants predominantly procured the material from a secondary context. Most of the crystal quartz (73.5%) were weathered and seem to have been collected from the nearby Maleme River channel which might have cut a geological formation where crystals were forming in large quantities. A lesser percentage of the crystals show that they were collected from the primary context (26.5%), and this implies that there are times when the PMG inhabitants would go and collect the crystals presumably in walkable distances. The crystal quartz also appears in different qualities and with different inclusions and this implies that they might have been collected from different sources. The inclusions best tell about the inclusions of the crystals since they form part of the crystals during the formation of the crystals.

From a technical point of view, the less frequency of the '*entame*' blanks as compared to the ratio of the blank to cores also implies that the actual reduction sequence of the crystals might have been initiated somewhere and not on site. However, considering the sizes of the crystals and the fact that the material is easy to carry even in large quantities, the observation might tell about the site activities of the PMG inhabitants during the MSA and LSA and how they organised their space.

The integration of the cores and blanks show that there was a change in the knapping technique during the reduction sequence. The crystals might have initially been reduced using the direct-free-hand technique to produce elongated blanks and then due to the reduced size of the crystals, the bipolar technique was employed to also try and produce mostly microlithic blanks.

## **7. CHAPTER SEVEN**

### **7.1. Conclusion**

The previous research at PMG by Cooke (1963) and later Walker (1995) showed that there were large quantities of crystal quartz within the MSA and LSA sequence. The presence of this material in such numbers was interesting, hence the current study.

The current study complimented the research by Cooke (1963) by clarifying the technological successions of PMG and Zimbabwe at large. It also better positioned the Zimbabwean Stone Age within the southern African context by taking an example of one specific raw material. The study aimed at understanding how the PMG inhabitants exploited crystal quartz in lithic production during the MSA and LSA periods. It was also aimed at exploring the ways in which crystal quartz was selected, knapped, shaped, retouched and finally discarded. The study evaluated how the employed chaînes opératoire varied through time at the site.

Crystal quartz is one of the raw materials exploited in lithic production during the Stone Age technological phases. This material has a specific physical and mechanical property which governs the way it is knapped. It is a variety of quartz which is characterised by its hyaline appearance and ordered atomic structure. Crystal quartz is a mineral which develops in the form of columnar-prismatic tendency with the well-developed faces of a hexagonal prism. Each crystal quartz piece is a faceted cylinder with well demarcated ridges between each of its crystal faces. The material also has a variable morphology.

This study was a part of the broader MATOBART project aimed at reinvestigating the Stone Age sequence of the Matopos at large and the frame of its Rock Art. The project commenced excavations at PMG in November 2018.

The study revealed that crystal quartz exploited at PMG was mainly sourced from the secondary context, however there was a change during the end of the Bambata; the results suggest that the sourcing in these layers was coming from the primary context.

Through the technological analysis and chaîne opératoire approach, the study revealed that there are phases when crystal quartz was more prominent at PMG than others, i.e. during the Maleme (12-10) and during the Amadzimba (3) techno-complexes.

The classification of the materials also showed that crystals could be divided into three technological categories, i.e. unmodified crystals, modified crystals and blanks. The distribution of these pieces varied as well during the MSA and LSA periods. The exploitation of crystal quartz at PMG was generally oriented towards the production of flakes; however recovered cores from the Maleme phase suggest that the technology was oriented towards the production of bladelets during this techno-complex. The exploitation of the crystals also followed the same criteria in terms of reducing the crystals, from the pyramid going towards the base. The bipolar technique was the most prominent as suggested with the cores, however the blanks show otherwise and as such this implies that the cores might have been reduced with bipolar just before discard because of the reduced size.

The study significantly helped in furthering our understanding on the hunter-gatherers, and their behaviours through technological studies. The exploitation of crystal quartz, producing blanks and tools showed the developed cognition of the hunter-gatherers as they understood the principles of knapping crystal quartz.

## **7.2. Recommendations**

The study looked at only the pieces of crystal quartz which had the facet or at least a remnant of a facet and as such it did not fully represent the full technology of the PMG crystal quartz.

With this in mind, I propose that in the future a technological study incorporating all the transparent quartz at PMG should be carried out so as to complement the data that was produced with this current study.

The analysed crystals showed different inclusions and these inclusions are indicators of the actual provenance of the crystals as such, there is need to conduct a characteristic and provenance study on the PMG crystal quartz. This will help determine the actual sources of the crystals. It will also aid to our understanding of the raw material provisioning strategies of the PMG hunter-gatherers.

The study aimed at positioning the PMG Stone Age sequence within the broader southern African context. This was done through the technological analysis of crystal quartz, however there is need for a detailed comparative study between the PMG assemblage and collections from other southern African sites where crystal quartz have been recovered. This will also help in differentiating those pieces which had been ascribed as crystal quartz whilst in actual fact is just transparent quartz.

## **REFERENCE LIST**

- Anon. 2009. Quartz: Mineral Information. <http://www.mineralminers.com/html>.
- Anthony, J.W., Bideaux, R.A., Bladh, K.W. & Nicholas, M.C. 2001. *Handbook of Mineralogy*, Mineral Data Publishing, Tucson, Arizona.
- Armstrong, A.L. 1931. Rhodesian Archaeological Expedition (1929): excavations in Bambata Cave and researches on prehistoric sites in Southern Rhodesia. *The Journal of the Royal Anthropological Institute of Great Britain and Ireland* 61: 239-276.
- Audouze, F. 2002. Leroi-Gourhan, a philosopher of technique and evolution. *Journal of Archaeological Research* 10(4): 277-306.
- Bar-Yosef, O. & Van Peer, P. 2009. The chaîne opératoire approach in Middle Paleolithic archaeology. *Current Anthropology* 5(1): 103-131.
- Barham, L.S. 1992. Let's walk before we run: an appraisal of historical materialist approaches to the later Stone Age. *South African Archaeological Bulletin* 47: 44-51.
- Beaumont, P.B. & Boshier, A.K. 1974. Report on test excavations in a prehistoric pigment mine near Potsmasburg, Northern Cape. *The South African Archaeological Bulletin* 29 (113/114): 41-59.
- Beaumont, P.B. & Vogel, J. C. 2006. On a timescale for the past million years of human history in central South Africa. *South African Journal of Science* 102: 217–228.
- Binneman, J. 1997. Use-wear traces on Robberg bladelets from Rose Cottage Cave. *South African Journal of Science* 93 (10): 479–81.
- Bird, C., Minichillo, T. & Marean, C.W. 2007. Edge damage distribution at the assemblage level on Middle Stone Age lithics: an image-based GIS approach. *Journal of Archaeological Science* 34: 771-780.

- Bisson, M.S. 1990. Lithic reduction sequences as an aid to the analysis of Late Stone Age quartz assemblages from the Luano Spring, Chingola, Zambia. *The African Archaeological Review* 8: 103-138.
- Bleed, P. 2001. Trees or chains, links or branches: conceptual alternatives for consideration of stone tool production and other sequential activities. *Journal of Archaeological Method and Theory* 8 (1): 101-127.
- Boëda, E. 1995. Levallois: a volumetric construction, methods, a technique. In O. Bar-Yosef & H.L. Dibble, (Eds), *The Definition and Interpretation of Levallois Technology. Monographs in World Archaeology*. No 23: 41–68.
- Brain, C.K & Cooke, C.K. 1967. A Preliminary Account of the Redcliff Cave Site in Rhodesia. *The Southern African Archaeology Bulletin* 21 (84): 171-187.
- Chiwara-Maenzanise, P. 2018. Morphological variability of the late Holocene microlithic backed tools from Pomongwe Cave Matobo, western Zimbabwe. Unpublished Masters Dissertation. University of Zimbabwe.
- Clark, A.M. 1997. The MSA/LSA transition in southern Africa: new technological evidence from Rose Cottage Cave. *The South African Archaeological Bulletin* 52(166):113-121.
- Cooke, C.K. 1957. The waterworks site at Khami, Southern Rhodesia: Stone Age and Proto-historic. *Occasional Papers of the National Museum of Southern Rhodesia* A3 (21): 1-43.
- Cooke, C.K. 1963. Report on excavations at Pomongwe and Tshangula Caves: Matopo Hills, Southern Rhodesia. *The South African Archaeological Bulletin* 18(71): 73-151.
- Cooke, C.K. 1969. *Rock Art of Southern Africa*. Cape Town: Books of Africa.
- Cooke, C.K. 1971. Excavation at Zombepata cave, Sipolilo District, Mashonaland, Rhodesia. *The South African Archaeology Bulletin* 26(103):104-126.

- Cooke, C.K. 1978. The Redcliff Stone Age site, Rhodesia. *Occasional Papers of the National Museums and Monuments of Rhodesia Series A: Human Sciences* 4: 45–73.
- Cooke, C.K. & K. R. Robinson. 1954. Excavations at Amadzimba Cave, Matopo Hills, Southern Rhodesia. *Occasional Papers of the National Museum of Southern Rhodesia*. 2 (19): 699-728.
- Cooke, C.K, Summers, R. & Robinson, R, K. 1966. Rhodesian prehistory re-examined. Part 1: The Stone Age. *Arnoldia* 2(12): 1-8.
- Dana, E.S. & Ford, W.E. 1922. *A Textbook of Mineralogy: With the Extended Treatise on Crystallographic and Physical Mineralogy*. London: Chapman and Hall, Limited.
- Deacon, H.J. & Deacon, J. 1999. *Human Beginnings in South Africa: Uncovering the Secrets of the Stone Age*. Cape Town: David Philip.
- Deacon, H. J. 2001. Modern human emergence: an African archaeological perspective. In: P. V. Tobias, M. A. Raath, J. Moggi-Cecchi & G. A. Doyle, (Eds), *Humanity from African Naissance to Coming Millennia—Colloquia in Human Biology and Palaeoanthropology*. Florence: Florence University Press, pp. 217–226.
- Delagnes, A., Wadley, L, Villa, P & Lombard, M. 2006. Crystal quartz backed tools from the Howiesons Poort at Sibudu Cave. *Southern African Humanities* 18 (1): 43-56.
- De la Peña, P. & Wadley, L. 2014. New knapping methods in the Howiesons Poort at Sibudu (KwaZulu-Natal, South Africa). *Quaternary International* 350: 26–42.
- De la Peña, P., Taipale, N., Wadley, L. & Rots, V. 2018. A techno-functional perspective on quartz micro-notches in Sibudu's Howiesons Poort indicates the use of barbs in hunting technology. *Journal of Archaeological Science* 93: 166-195.
- De la Peña, P., Val, A., Stratford, D. J., Colino, F., Esteban, I., Fitchett, J.M.,

- Hodgskiss, T., Matembo, J. & Moll, R. 2018. Revisiting Mwulu's Cave: new insights into the Middle Stone Age in the southern African Savanna biome. *Archaeological and Anthropological Sciences* 11(7): 3239-3266.
- De Lombera Hermida, A. 2009. The Scar Identification of Lithic Quartz Industries. In F. Sternke, L. Eigeland and L.-J. Costa, (Eds), *Non-Flint Raw Material Use in Prehistory: Old Prejudices and New Directions*. Oxford, British Archaeological Reports International Series 1939, pp. 5-11.
- Driscoll, K. 2010. Understanding quartz technology in early prehistoric Ireland Volume 1 of 2. Thesis submitted to the University College Dublin for the degree of PhD in the College of Arts and Celtic Studies.
- DuBois, T.H. 2009. *An Introduction to Shamanism*. Cambridge University Press, New York.
- Eliade, M. 1972. *Shamanism: Archaic Techniques of Ecstasy*. 2nd ed. Princeton University Press, Princeton, Massachusetts.
- Foley, R. & Lahr, M.M. 1997. Mode 3 technologies and the evolution of modern humans. *Cambridge Archaeological Journal* 7(1): 3-36.
- FrondeL, C. 1962. *The System of Mineralogy of James Dwight Dana and Edward Salisbury Dana*. 7<sup>TH</sup> Edition, Volume III. New York: John Wiley and Sons, Inc.
- Gardner, T. 1928. Excavations in a Wilton Industry at Gokomere, Fort Victoria, Southern Rhodesia. *Journal of the Royal Anthropological Institute* 58: 497-510.
- Goodwin, A.J.H. & C. van Riet Lowe 1929. The Stone Age cultures of South Africa. *Annals of the South African Museum* 27: 1-289.
- Grün, R. & Beaumont, P. B. 2001. Border Cave revisited: a revised ESR chronology. *Journal of Human Evolution* 40: 467-482.

- Harmand, S., Lewis, J.E., Feibel, C.S., Lepre, C.J., Prat, S., Lenoble, A., Boës, X., Quinn, R.L., Brenet, M., Arroyo, A. & Taylor, N. 2015. 3.3-million-year-old stone tools from Lomekwi 3, West Turkana, Kenya. *Nature* 521(7552): 310.
- Henshilwood, C.S. & Marean, C.W. 2003. The origin of modern human behaviour: a review and critique of models and test implications. *Current Anthropology* 44: 627–65.
- Högberg, A. & L. Larsson. 2011. Lithic technology and behavioural modernity: new results from the Still Bay site, Hollow Rock Shelter, Western Cape Province, South Africa. *Journal of Human Evolution* 61: 133–155.
- Hubbard, P. 2018. The Rock Art of the Matobo Hills World Heritage Area, Zimbabwe: Management and Use, c 1800 to 2016. *Conservation and Management of Archaeological Sites* 20(2): 76-88.
- Ingram, P. 1960. A preliminary account of the ecology of the vegetation of the South Matopos I.C.A. *Rhodesian Agricultural Journal* 57(4): 319-30.
- Inizan, M.L, Reduron-Ballinger, M., Roche, H. & Tixier, J. 1999. *Technology and Terminology of Knapped Stone*. Nanterre: CREP.
- Jones, N. 1933. Excavations at Nswatugi and Madiliyangwa, and notes on new sites located and examined in the Matopo hills, Southern Rhodesia, 1932. *Occasional Paper of the National Museum, Southern Rhodesia* 1: 1-44.
- Kannegaard, R. N. 2015. Quartz Crystal Microblades Function in the Salish Sea Region of Washington State during the Locarno Beach Phase (3500-2400 BP). Masters Thesis, Western Washington University.
- Klein, R.G., 2000. Archaeology and the evolution of human behaviour. *Evolutionary Anthropology: Issues, News, and Reviews* 9(1): 17-36.
- Lemonnier, P. 1992. *Technological Choices: Transformation in Material Cultures since the Neolithic*. London, Routledge.

- Leroi-Gourhan, A. 1993. *Gesture and Speech*. Cambridge, MIT Press.
- Lombard, M., Wadley, L., Deacon, J., Wurz, S., Parsons, I., Mohapi, M., Swart, J., & Mitchell, P. 2012. South African and Lesotho Stone Age sequence updated. *South African Archaeological Bulletin* 67: 123–144.
- MacGregor, A.M. 1951. Some milestones in the Pre-Cambrian of Southern Rhodesia. *Proceedings of the Geological Society of South Africa* 54: 27-71.
- Marufu, H. 2012. *Foraging communities of the Murewa-Mutoko landscape: an archaeological study of human behaviour during the Terminal Pleistocene and Holocene epochs*. PhD thesis, University of Dar es Salaam, Tanzania.
- Mason, R. J. 1962. *Prehistory of the Transvaal*. Johannesburg: University of the Witwatersrand Press.
- McBrearty, S. & Brooks, A.S. 2000. The revolution that wasn't: a new interpretation of the origin of modern human behaviour. *Journal of Human Evolution* 39: 453–563
- Mitchell, P.J. 1995. Revisiting the Robberg: new results and a revision of old ideas at Sehonghong Rock Shelter, Lesotho. *South African Archaeological Bulletin* 50: 28–38.
- Mitchell, P.J. & Steinberg, J. 1992. Ntloana Tsoana: a Middle Stone Age sequence from western Lesotho. *South African Archaeological Bulletin* 47(15): 26–33.
- Modikwa, B. 2008. *Lithic technology and introduction of pottery in southern Africa*. Unpublished MSc Thesis. Johannesburg: University of the Witwatersrand.
- Morgado, A., Lozano, J.A., Sanjuan, L.G., Trivino, M.L., Odriozola, C.P., Irisarri D.L., & Flores, A.F. 2016. The allure of rock crystal in Copper Age southern Iberia: Technical skill and distinguished objects from Valencina de la Concepcion (Seville, Spain). *Quaternary International* 424: 232-249.

- Nami, H.G. 2009. Crystal Quartz and Fishtail Projectile Points: Considerations on Raw Material Selection by Paleo South Americans. *Current Research in the Pleistocene* 26: 9-12.
- Novikov, V.P and Radililovsky, V.V. 1990. Quartz anisotropy in stone-age artifacts of the Hissar. *Cahiers du Quaternarie* 17: 592-598.
- Orton, J. 2006. The Later Stone Age lithic sequence at Elands Bay, Western Cape, South Africa. *Southern African Humanities* 18(2): 1-28.
- Orton, J. 2008. Later Stone Age ostrich eggshell bead manufacture in the Northern Cape, South Africa. *Journal of Archaeological Science* 35: 1765-1775.
- Orton, J. & Halket, D. 2010. Stone tools, beads and a river: Two Holocene microlithic site at Jakkalsberg in the Northwestern Richtersveld, Northern Cape, South Africa *South African Archaeological Bulletin* 65 (191): 13-25.
- Pargeter, J., Loftus, E., Mackay, A., Mitchell, P & Stewart, B. 2018. New ages from Boomplaas Cave, South Africa, provide increased resolution on late/ terminal Pleistocene human behavioural variability. *Azania: Archaeological Research in Africa* 53(2): 156-184.
- Pargeter, J. and Hampson, J. 2019. Quartz crystal materiality in Terminal Pleistocene Lesotho. *Antiquity* 93(367): 11-27.
- Petrin, V.T.,Nokhrina, T.I., Kulik, N.A & Usacheva, I.V. 2012. Upper Paleolithic rock crystal artifacts from the southeastern shore of lake Bolshiye Allaki, the Southern Urals. *Archaeology Ethnology & Anthropology of Eurasia* 40 (4): 28–40.
- Petrovic, V.B., Jovanovic, D.M., Stojanovic, M. & Andric, V. 2015. The origin, production and use of quartz crystals in the Neolithic of Serbia: Vinca-Belo Brdo. *Quaternary International* 30: 1-11.

- Plug, I. 1981. Some research results on the late Pleistocene and early Holocene deposits of Bushman Rock Shelter, eastern Transvaal. *South African Archaeological Bulletin* 36: 14–21.
- Porraz, G., Val, A., Dayet, de la Pena, P., Douze, K., Miller, C.E., Murungi, M.L., Tribolo, C., Schmid, V.C. & Sievers, C. 2015. Bushman Rock Shelter (Limpopo, South Africa): a perspective from the edge of the Highveld. *South African Archaeological Bulletin* 70: 166–179.
- Porraz, G., Igreja, M., Schmidt, P. & Parkington, J.E. 2016. A shape to the microlithic Robberg from Elands Bay Cave (South Africa). *Southern African Humanities* 29: 203–247.
- Porraz, G., Val, A., Tribolo, C., Mercier, N., De La Peña, P., Haaland, M. M., & Schmid, V. C. 2018. The MIS5 Pietersburg at ‘28’ Bushman Rock Shelter, Limpopo Province, South Africa. *PLoS ONE* 13(10): <https://doi.org/10.1371/journal.pone.0202853>
- Reher, C.A. & Frison, G.C. 1991 Rarity, Clarity, Symmetry: Quartz Crystal Utilization in Hunter-Gatherer Stone Tool Assemblages. In: Montet-White, A and Holen, S. (eds.), *Raw Material Economies among Pre-Historic Hunter Gatherers: 375-397*. Lawrence :University of Kansas Press.
- Robbins, L.H. 1985. The Manyana Rock Painting Site. *Botswana Notes and Records* 17: 1-14.
- Robinson, K.R. 1958. Some Stone Age sites in the Inyanga district. In Summers, R. (ed), *Inyanga: prehistoric settlements in southern Rhodesia 270-309*. Cambridge: Cambridge University Press.
- Rots, V., Lentfer, C., Schmid, V.C., Porraz, G & Conard, N.J. 2017. Pressure flaking to serrate bifacial points for the hunt during the MIS5 at Sibudu Cave (South Africa). *PLoS ONE* 12(4). <https://doi.org/10.1371/journal.pone.0175151>

- Sachanbinski, M., Girulski, R., Bobak, D & Łydzba-Kopczynska, B. 2008. Prehistoric rock crystal artefacts from Lower Silesia (Poland). *Journal of Raman Spectroscopy* 39: 1012-1017.
- Sauter, M-R., Gallay, A., & Chaix, L. 1971. Le Neolithic du Niveau du Petit-Chasseur A Sion- Valais. *Sonderdruck* 56 : 54-66.
- Schlanger, N. 1994. Mindful technology: unleashing the chaîne opératoire for archaeology of mind. In: Renfrew, C., Zubrow, E.B. and Audouze, F. (eds.), *The Ancient Mind: Elements of Cognitive Archaeology*, pp.143-151. Cambridge: Cambridge University Press.
- Schlanger, N. 2005. The chaîne opératoire. In: Renfrew, C. and Bahn, P. (eds.), *Archaeology: the Key Concepts*, pp. 25-31. London: Routledge.
- Schofield, J.F. 1940. A report on the pottery from Bambata Cave. *South African Journal of Science* 37: 361-372.
- Shott, M. 2003. Chaîne opératoire and reduction sequence. *Lithic technology* 28(2): 95-105.
- Simons, H.A. 1968. A late Stone Age occupation site in the Hillside area of Bulawayo. *South African Archaeological Bulletin* 23: 45-9.
- Smith, C. G. 1968. Some aspects of the Geology of the Matopos. B.Sc. Honours Project. Geology Department: University of Rhodesia.
- Sørensen, M. & Desrosiers, P. 2008. *Technology in Archaeology*. Copenhagen: The Danish National Museum.
- Soressi, M. & Geneste, M-J. 2011. The history and efficacy of the *chaîne opératoire* approach to lithic analysis: studying techniques to reveal past societies in an evolutionary perspective. *PaleoAnthropology* 2011: 334-350.  
<https://doi:10.4207/PA.2011.ART63>

- Soriano, S., Villa, P. & Wadley, L. 2007. Blade technology and tool forms in the Middle Stone Age of South Africa: the Howiesons Poort and post-Howiesons Poort at Rose Cottage Cave. *Journal of Archaeological Science* 34: 681–703.
- Thompson, J.C., Mackay, A., Wright, D.K., Welling, M., Greaves, A., Gomani-Chindebvu, E. & D. Simengwa. 2012. Renewed investigations into the Middle Stone Age of northern Malawi. *Quaternary International* 270: 129-139.
- Tobias, P.V. 1949. The excavation of Mwulu's Cave, Potgietersrust district. *South African Archaeological Bulletin* 4: 2–13.
- Villa, P., Soriano, S., Tsanova, T., Degano, I., Higham, T., d'Errico, F., Backwell, L., Lucejko, J., Colombini, M.P. & Beaumont, P.B. 2012. Border Cave and the beginning of the Later Stone Age in South Africa. *Proceedings of the national Academy of Sciences* 109 (33): 13208–13.
- Wadley, L. 1987. *Later Stone Age Hunters and Gatherers of the Southern Transvaal: Social and Ecological Interpretation*. Oxford: Archaeopress.
- Wadley, L. 1992. Reply to Barham: aggregation and dispersal phase sites in the Later Stone Age. *South African Archaeological Bulletin* 47: 52–55.
- Wadley, L. 2005. A typological study of the final Middle Stone Age stone tools from Sibudu Cave, KwaZulu-Natal. *South African Archaeological Bulletin* 60: 1–13.
- Wadley, L. 2008. The Howieson's Poort industry of Sibudu cave. *South African Archaeological. Society Goodwin Series* 10: 122-132.
- Wadley, L. 2012. Two 'moments in time' during Middle Stone Age occupations of Sibudu, South Africa. *Southern African Humanities* 24: 79–97.
- Wadley, L. 2015. Those marvellous millennia: the Middle Stone Age of Southern Africa, *Azania: Archaeological Research in Africa* 50(2): 155-226.

- Walker, N.J. 1980. Late Stone Age Research in the Matopos. *South African Archaeology Bulletin* 35 (131): 19-24.
- Walker, N. 1995. *Late Pleistocene and Holocene Hunter-gatherers of the Matopos*. Uppsala: Societas Archaeologica Uppsaliensis.
- Walker, N. & Thorp, C. 1997. Stone Age Archaeology in Zimbabwe. In: Pwiti, G. (ed.), *Caves, Monuments and Texts. Zimbabwean Archaeology Today*, pp. 9-32. Uppsala: Studies in African Archaeology.
- Wurz, S. 1999. The Howiesons Poort backed artefacts from Klasies River: an argument for symbolic behaviour. *South African Archaeological Bulletin* 54(169): 38-50.
- Yellen, J.E. & Brooks, A.S. 1989. The Late Stone Age Archaeology of the !Kangwa and /Xai /Xai Valleys, Ngamiland. *Botswana Notes and Records*. 20: 5-27.