

TITLE

Investigation into the various parameters affecting the application of clear thermosetting powders by electrostatic spraying onto decorated tinfoil and its ability to withstand tooling deformation without any noticeable breakdown.

Included in the investigation is the design and construction of a pilot spraying and curing unit.

P. KYRIAKOU

'A thesis submitted to the Faculty of Engineering, University of the Witwatersrand, Johannesburg, in fulfillment of the requirements for the degree of Master of Science in Engineering'.

Oct 1963

To my dearest wife Katia, whose love and encouragement
are with me all the time.

ACKNOWLEDGEMENT

I would like to take this opportunity and express my thanks to Metal Box S.A. Limited for assisting me in every way with this thesis.

A special thanks to the Technical Manager of Diversified Packaging Division, Mr. A.J. McLeish, whose initiative, support and encouragement with this report have been invaluable.

I extend my thanks to Prof. R.T. Jamieson for his valuable time, his enthusiasm during consultation hours and all that which came before it.

I would like to thank Mr. J. Molloy and Mr. N. Judd of A.E.C.I. for their valuable assistance during the experimenting period of this project.

I am greatly indebted to Mrs. C. Dixon for her organising and typing and the enthusiasm with which she applied herself to this task, and to Mrs. C. Sawtelle for her valuable assistance in typing this thesis.

I am grateful to Messrs. M. Bauer, W. Melville, C. Oosthuizen, W. Harrison, T. Baptista and J. Hassan of Metal Box Technical Department for suggestions and assistance they provided.

To Mr. A. Heiberg of Metal Box VanCerberijlpark I express my gratitude.

To A.E.C.I. Ltd, C.S.I.R., Nu Aire (Pty) Ltd, GEMF Systems, Mr. N. Reilly of Research Inc. (U.S.A.) and all those who have indirectly helped me with this work, a kind thanks.

DECLARATION

I declare that this thesis is my own unaided work.
It is being submitted for the degree of Master of
Science in Engineering in the University of the
Witwatersrand, Johannesburg.

It has not been submitted before for any degree or
examination in any other University.

SIGNED 

THIS DAY OF 1982

A B S T R A C T

The report is intended to provide a survey of electrostatic powder coating principle, the parameters involved and how it can be used to give a protective and decorative thin surface film on printed tinfoil, which would in turn withstand a tooling deformation.

Phenomena associated with electrostatic powder coating are examined and the principle applications of the process to film production are described.

In addition to an investigation of the conventional type process currently used in industry, new developments are discussed.

The application is the hardware range components produced by (A.P. 10). Metal Box S.A. Limited, which would compete favourably with plastic products, serving the same market because of a durable, corrosion resistant, scratch free surface.

This survey will form the grounding work for further investigation into different areas and processes for decorating tinfoil.

Assumptions and limitations of the work have been based on available local and overseas data and estimates of accuracy of numerical results have been recorded as $\pm 5\%$.

NOTE :

Where specific reference* is not made and to avoid repetition of the below mentioned institutions and companies, it should be noted that inspiring information was also retrieved through discussions made and literature read made available by :-

METAL BOX S.A. LTD and METAL BOX U.K.

A.E.C.I. LTD

CSIR

NU-AIR (PTY) LTD

RESEARCH INCORPORATED (U.S.A.)

GEMA -LUTRO SYSTEMS (PTY) LTD

BRENDESTULL (PTY) LTD

PRODUCTION COATERS (PTY) LTD

P.G. GLASS LTD

and other various powder coating establishments.

TABLE OF CONTENTS

1. METAL BOX APPLICATION
2. MARKETING CONSIDERATION
3. PROJECT DEVELOPMENT
 - 3.1. Objective
 - 3.2. Procedure
 - 3.2.1. Stage 1
 - 3.2.2. Stage 2
 - 3.2.3. Stage 3
4. TERMINOLOGY
5. MANUFACTURING PROCESS - STAGE
 - 5.1. Incoming raw material
 - 5.2. Sheet sizes
 - 5.3. Determination of thickness
 - 5.4. Tincoating
 - 5.5. Tolerances
 - 5.5.1. Thickness
 - 5.5.2. Nominal thickness of individual sheets
 - 5.6. Size dimensions
 - 5.6.1. Determination of linear dimensions
 - 5.6.2. Tolerances of linear dimensions
 - 5.6.3. Sheared sheets
 - 5.6.4. Out of square
 - 5.7. Classification
 - 5.8. Packing
6. MANUFACTURING OPERATIONS
 - 6.1. Cutting
 - 6.1.1. Notching
 - 6.1.2. Rolling
 - 6.1.3. Automatic seaming
 - 6.1.4. Flanging
 - 6.1.5. Seaming and curling

7. BRIEF HISTORY OF PRINTING

- 7.1. Lithographic printing
 - 7.1.1. Sketch
 - 7.1.2. Reproduction
 - 7.1.3. Filters
 - 7.1.4. Platemaking
 - 7.1.5. Printing
 - 7.1.6. Delivery
 - 7.1.7. Feeding
 - 7.1.8. Dumping
 - 7.1.9. Inks
 - 7.1.10. Inking
 - 7.1.11. Printing
 - 7.1.12. Stoving
 - 7.1.13. Varnishing and coating
 - 7.1.14. Lacquers

8. DEVELOPMENT BACKGROUND

9. REPORT ON UP TO DATE RESULTS

10. RESEARCH AND DEVELOPMENT

- 10.1. Objective of Research
- 10.2. Scope of development
- 10.3. Analysis of each phase

11. DEFINITIONS

- 11.1. Powder
- 11.2. Powder coatings
- 11.3. Historic factors
- 11.4. Powders
 - 11.4.1. Discussion on Powders
 - 11.4.2. Thermosetting powder coatings
 - 11.4.3. Thin film decorated epoxies

- 11.4.4. Epoxy polyester hybrid
- 11.4.5. Polyester resin based and acrylics

12. POWDER APPLICATION METHODS

- 12.1. Electrostatic spraying
- 12.2. Automatic re-cycle equipment
- 12.3. Fluidised bed
- 12.4. Electrostatic fluid bed

13. SYSTEM DESIGN

14. CURING

15. COMPARISON OF E/S AND FLUIDISED BED TECHNIQUES

- 15.1. Advantages of E/S Compared to F.B.
- 15.2. Disadvantages of E/S Compared to F.B.

16. POWDER - RAW MATERIAL

- 16.1. Powder preparation
- 16.2. Shelf stability of powders
 - 16.2.1. Sintering
 - 16.2.2. B-Staging
 - 16.2.3. Moisture

17. ULTRA THIN FILM APPLICATIONS

18. FORMULATION PROBLEMS

19. FACTORS AFFECTING POWDER CHOICE

- 19.1. Physical properties
- 19.2. Chemical properties
- 19.3. Outdoor durability
- 19.4. Curing requirements

- 11.4.1. Epoxy polyester hybrid
- 11.4.5. Polyester resin based and acrylics

12. POWDER APPLICATION METHODS

- 12.1. Electrostatic spraying
- 12.2. Automatic re-cycle equipment
- 12.3. Fluidised bed
- 12.4. Electrostatic fluid bed

13. SYSTEM DESIGN

14. CURING

15. COMPARISON OF E/S AND FLUIDISED BED TECHNIQUES

- 15.1. Advantages of E/S Compared to F.B.
- 15.2. Disadvantages of E/S Compared to F.B.

16. POWDER - RAW MATERIAL

- 16.1. Powder preparation
- 16.2. Shelf stability of powders
 - 16.2.1. Sintering
 - 16.2.2. B-Staging
 - 16.2.3. Moisture

17. ULTRA THIN FILM APPLICATIONS

18. FORMULATION PROBLEMS

19. FACTORS AFFECTING POWDER CHOICE

- 19.1. Physical properties
- 19.2. Chemical properties
- 19.3. Outdoor durability
- 19.4. Curing requirements

- 20. CURING OF POWDER COATINGS
 - 20.1. RADIATION CURING
 - 20.1.1. REACTIVABLE GROUPS
 - 20.1.1.1. Oligomers
 - 20.1.1.2. Reactive Diluents
 - 20.1.1.3. Photoinitiators and Photosensitizers
 - 20.1.2. Advantages and Disadvantages of Radiation Curing Systems over Conventional Curing Systems
 - 20.1.2.1. Advantages
 - 20.1.2.2. Disadvantages
 - 20.1.3. Radiation Curing Process by UV and EB
 - 20.1.4. Infra Red
- 21. HIGH VELOCITY OVENS
 - 21.1. POST HEAT SYSTEMS
 - 21.2. FLOW AND CURE PROPERTIES
 - 21.3. MELT VISCOSITY
- 22. INFRA RED CURE FOR POWDER
- 23. OUTLINE OF BASIC PROCESS
 - 23.1. Scope
 - 23.2. Process
 - 23.3. Types of components
 - 23.4. Powder coating equipment and procedure
- 24. SYSTEM DESIGN CONSIDERATIONS FOR OPTIMUM EQUIPMENT UTILISATION IN POWDER COATING
 - 24.1. DESIGN CONSIDERATIONS FOR OPTIMUM EQUIPMENT UTILISATION
 - 24.1.1. Conveyors
 - 24.1.2. Coating and collection equipment

- 28.3. Type of Heating
- 28.4. Powder usage and recovery

- 29. STORAGE STABILITY CONSIDERATIONS
 - 29.1. Factors Influencing storage
 - 29.2. End users experiences

- 30. ELECTROSTATIC CONSIDERATIONS
 - 30.1. Abstract
 - 30.2. Properties of powder

- 31. ELEMENTS OF ELECTROSTATIC POWDER COATING SYSTEM
 - 31.1. Powder delivery apparatus
 - 31.2. Powder gun
 - 31.3. Movement of charged particles in electric field
 - 31.4. Particle deposition
 - 31.5. Adhesion
 - 31.6. Electrical safety considerations
 - 31.7. Back ionisation
 - 31.8. Air versus electrostatic forces
 - 31.9. Powder feed rate
 - 31.10. Areas for further work and future trends

- 32. GUN PERFORMANCE
 - 32.1. Abstract
 - 32.2. Discussion
 - 32.2.1. Transfer efficiency
 - 32.2.2. Flow rate
 - 32.2.3. Production rate
 - 32.2.4. Cost

- 33. STATIC ELECTRICITY
 - 33.1. Abstract
 - 33.2. The product requirement

- 33.3. Technical basis for product requirement
- 33.4. The Spengler (SR) Ionisor
- 33.5. Some of the facts and characteristics of Ionisation
- 33.6. Description of the (SR) ionisor
- 33.7. Information about the (SR) system
- 33.8. Electrostatic grounding
- 33.9. Operation

34. CHARGE DECAY

- 34.1. Review of charge decay
- 34.2. Experimental
 - 34.2.1. Description of the apparatus
 - 34.2.2. Procedure
- 34.3. Results and Discussions
 - 34.3.1. Charge decay of various powders
 - 34.3.2. Temperature
 - 34.3.3. Relative humidity
 - 34.3.4. Charge decay and particle deposition

35. SYSTEM RELIABILITY

- 35.1. Synthesis
- 35.2. Reliability
 - 35.2.1. Time of passing through the dosing device
 - 35.2.2. Time of passing through the spraying nozzle
 - 35.2.3. Time of transport between the spraying nozzle and the substrate

36. PILOT PLANT DECAY

- 36.1. List of parameters for laying out a powder coating line
- 36.2. Breakdown of activities involved in the installation of a powder coating line
- 36.3. Pilot plant design considerations

- 36.3.1. Powders
 - 36.3.2. Internal selling
 - 36.3.3. Plant design
37. PILOT PLANT DESCRIPTION
38. SURFACE FINISH CONSIDERATIONS
39. POWDER EVALUATIONS
- 39.1. Mechanical properties
 - 39.2. Reduction in gloss by blending powders with different activities
 - 39.3. Powder coating materials
40. EQUIPMENT EVALUATION
41. ULTRA THIN POWDER COATING CAPABILITIES
- 41.1. Abstract
 - 41.2. Discussion
42. TRANSPORTATION OF SHEETS
- 42.1. Vertical hanging
 - 42.2. Gripper edge pressure
 - 42.3. Horizontal conveyor
43. ANTI CORROSION AND CHEMICAL RESISTANCE
44. FORMING AND DRAWING OF TINPLATE
- 44.1. Forming mode
 - 44.2. Ideal stretching
 - 44.3. Ideal drawing
 - 44.4. Wrinkling
 - 44.5. Lubrication

- 45. GEL PROCEDURES
- 46. APPEARANCE OF CURED FILMS
- 47. ULTRA THIN POWDER COATINGS
- 48. THE IMPORTANCE OF OPACITY IN THIN FILM COATINGS
 - 48.1. Coating procedure
 - 48.2. Effect of hiding power on cost
 - 48.3. Measuring hiding power
 - 48.4. Experimental
 - 48.5. Theory
 - 48.6. Procedure
 - 48.7. Cost of coating
 - 48.8. Energy consumption analysis and cost
- 49. COATING THICKNESS MEASUREMENT
 - 49.1. Measurement accuracy and product variation
 - 49.2. Different test areas
 - 49.3. Non destructive measurement of coating thickness
- 50. CONCLUDING REMARKS
 - 50.1. Powder recovery
- 51. CYCLONES
 - 51.1. Introduction
 - 51.2. Purpose and description of test programme
 - 51.3. Scale up technique
 - 51.4. Features and accessories
- 52. DUST COLLECTOR

TABLES

1. Quality and Temper designations
2. Tin Coatings - Applications
3. Powder Coating Applications
4. Types of Heating
5. Effect of Resin Tg on Physical Stability
6. Tests on Chemical Stability of a 'standard' epoxy powder
7. Effect of Variables on Transfer Efficiency
8. Cause - effect relationship for gun performance
9. Change Decay of Powder Coatings
10. Powders - Constants $C_1 + C_2$
11. Surface voltage after 15 seconds of various powders.

FIGURES

1. Trace of Differential Scanning Calorimeter (D.S.C.)
2. Viscosity contours for Powder Coatings
3. D.S.C. for Epoxy powder
4. Melt viscosities of epoxy powder coatings at various temperatures
5. Viscosity contours for Powder Coatings
6. Basic arrangement of E.P.S. system
7. Viscosity - Temperature profile of a thermoset powder
8. Angles of repose and internal friction
9. Particle size distribution curve
10. Inclined plane flow test
11. Spiral flow mould
12. Test of edge coverage on pre-heated square steel bars
13. Spengler ionisor
14. Various SR Bars
15. Function of SR ionisor
16. Schematic diagram of the surface charge tester
17. Plot of a typical decay in the surface voltage with time for an epoxy polyester powder at 45°C and 14% relative humidity.
18. Plots of the relaxation times for the decay of charge from epoxy polyester powder at 45°C and 14% relative humidity.

19. Plot of $\log \frac{V_1}{V_1 + V_2}$ vs temperature for an epoxy polyester powder at 14% relative humidity.
20. Plots of the relaxation times for the decay of charge from epoxy polyester powder coating vs relative humidity at 30°C.
21. Plot of $\log \frac{V_1}{V_1 + V_2}$ vs relative humidity for an epoxy polyester powder at 30°C.
22. Forces acting on powder particle
23. Plot of % efficiency vs voltage
24. Thickness vs °C keeping humidity constant
25. Thickness vs humidity keeping temperature constant
26. Sp. gravity vs coverage
27. Opacity - chart
28. Coverage at C.R. = 0,98
29. Acceleration in 300mm Diameter cyclone vs cyclone efficiency
30. Stokes particle diameter vs collection efficiency

APPENDICES

1. Status report - sample
2. Safety : explosion energy - voltage
3. Calculation of coverage
4. Heating requirement for I.R. curing
5. I.R. oven size price quotation
6. Pilot plant capex
7. Spoilage figures
8. Activities
9. Samples
10. Hardware book
11. Production requirements
12. Tests and results
13. Conveying air pressure - dosage relationships
14. Extra cost for increasing one linear dimension of sheets

APPENDICES

1. Status report - sample
2. Safety : Explosion energy - voltage
3. Calculation of coverage
4. Heating requirement for I.R. curing
5. I.R. oven size price quotation
6. Pilot plant capex
7. Spoilage figures
8. Activities
9. Samples
10. Hardware book
11. Production requirements
12. Tests and results
13. Conveying air pressure - dosage relationships
14. Extra cost for increasing one linear dimension of sheets

INTRODUCTION

The rapid growth of the powder coating industry during the past decade can be attributed in part to the availability of improved coating materials and coating equipment.

A growing recognition of the need for better communication of requirements and problems among equipment manufacturers, powder suppliers and users has undoubtedly enhanced progress.

One might question the need to dig into details of the electrostatics in-as-much-as many powder coating applications can be handled readily with available equipment and materials and with little expertise on the part of the operator.

This, indeed is one of the recognised advantages of powder coating. However, there are many potential applications for powder spraying wherein problems arise because some of the requirements are not easily met.

Although a few of these requirements are generally recognised, it is probably fair to say that many aspects of powder coating remains poorly understood.

Part of this report discusses the various influences which affect the quality of the powder coating and refers to measurement techniques that are in the analysis of powder coating problems.

In some instances the need for further research to clarify observed behaviour is indicated.

1. METAL BOX APPLICATION

Electrostatic powder coating has emerged to give demonstrably better mechanical, chemical and corrosion protection than the usual coatings. The use of this coating to the hardware range of our products would ensure a homogeneous plastic surface coating, exhibiting the endurance characteristics which have long been desired by the consumer.

The overall process can be divided into three broad categories namely :-

1. Printing of tinplate
2. Powder coating of printed tinplate
3. Tooling of coated tinplate to form the end component.

In principle the above stages involve :-

- a) Tinplate is produced by required size either by in house coil shearing or by direct size order from Iscor.
- b) Sized sheets are put through the printing process for decoration purposes.
- c) Decorated sheets are then powder coated with clear powder to produce a certain number off components per sheet.
- e) Components are stored in stock and later transported for dispatch, packed in containers.

Potential market in units would be approximately 70% on flat surface components such as trays and soup plates. The process would offer stock flexibility and savings on long runs and heavy volume production and it would minimise the damage of the components during manufacture and transportation. (App. 7)

2. MARKETING CONSIDERATIONS

Powder coating on metal substrate generates the possibility of metal hardware competing with plastics. The consumer is expected to feel a greater appeal than at present.

Two factors are very important for a decisive marketing strategy

- quality of product
- price of product

This means that we are looking at a high performance coating and we are referring to an applied film where presence greatly enhances the function and usefulness of the coated product.

Amongst the characteristics a high performance coating should possess are : corrosion resistance to aggressive chemicals, good release from sticky products, good thermal stability and good mechanical stability such as adhesion, toughness and flexibility. Needless to say there is no single coating, even forgetting cost, which possesses all of these virtues to the nth degree. Each high performance coating is limited to a particular area of usefulness.

It is up to the researcher to analyse a potential customer's need and to select, recommend and quote an acceptable coating. This process must ultimately be supported by competitive price and production reliability.

Powder coating has not taken the share of the market that some of the more optimistic predictions envisaged. Nevertheless, it has grown steadily, the technology has improved and it is proving to be not only a satisfactory coating method for a growing list of applications. Powder coating should be studied carefully by all finishers and its limitations as well as capabilities listed for each potential application. Suppliers should evaluate the market carefully and realistically to see how it fits into each company's plans for the future.

For many years, the value of powder coating has evolved through its solvent free application. A rapidly growing consideration for powder is in the sphere of corrosion protection and reduction of resource recycling through higher quality protection from hostile environments. The consumer gains in many ways and it is our opinion that consumers will become more insistent that product service life be improved. The substantial replacement of metal components by plastics will continue to gain, but it seems practical to us to bring out the advantages of both metal and plastic by utilizing metal's structural strength and enhancing the resistance to the challenges of the environment through the use of functional plastic coatings.

3. PROJECT DEVELOPMENT

3.1. Objective

In January 1981 the project objective was established as 'to improve the quality of tinplate surface coating in the hardware range having in mind that the resistance to wear which the usual wet lacquers offer to tinplate lacks the endurance characteristics which are desirable by the customers.'

3.2. Procedure

3.2.1. Stage I

- a) Investigations into the market of electrostatic powder coating equipment.
- b) Discussions with technical representatives from this market.
- c) Discussions on performance and limitations of existing equipment.
- d) Discussions on powder characteristics and plastic layer formation.
- e) Visit to established powder coating plants.

3.2.2. Stage II

- a) Considerations of equipment and set up cost of a pilot plant.
- b) Discussions detailing forecasts of sales.
- c) Obtain samples for evaluation with sales department.

3.2.3. Stage III

Justification of new development for volume production.

A summary of progress was issued every month listing the various activities performed towards the completion of the project. Some of these can be referred to in the Appendix. (App. 8)

Finally we had reached the stage where a pilot plant was desirable for different reasons such as -

- a) Acquiring knowledge of the process of powder coating
- b) Testing the process as an in-house exercise
- c) Obtaining samples for evaluation under own conditions and acceptability tests. (App. 9)

Eventually in our conclusions we developed optimistic, pessimistic and probable outcomes for each of the powders used.

Also, as in the marathon analogy a number of today's powder producers are clearly ahead of the pack. We have carefully avoided discussing thick film, thermoplastic powders, because of time and because everything is so different about them.

To summarise our remarks -

1. Thin film, thermosetting powder coatings should be viewed critically for what they are and what they will become. They are superb new industrial coatings, but they have limitations. As such, thin film powders will emerge only as a big, specialty-coatings business.

The truth is that powder coating is a very exciting technology where it is applicable. In some ways powder coating is more exciting today than it was five years ago because much more is known about it.

2. By a 4-3 margin, powder has been judged to be more * expensive than a corresponding liquid coating. No attempt was made in the survey to determine whether total cost of equipment amortization, materials, was being considered or whether only material cost was judged.

3. The manufacturer who has a huge investment in his present finishing system and may not be able to justify scrapping it unless he has to expand or unless he is forced to powder for other reasons. Powder marketing suffers from something that has nothing to do with technology. It involves corporate financial planning, return on investment, interest rates and other factors.
4. Suppliers point out that if one envisions a future of higher priced solvents and higher production of powders, the relative costs of powder and liquid coating materials should tilt in favour of powder.
5. It is fair to note in discussing cost and economic justification that companies usually find it difficult to predict what powder coating will mean in terms of production rates, reject rates, the possibility of post finish machining the use of less skilled operators, less care in packaging and handling, less damage in the field and better customer satisfaction.

Instead, cost justification tends to centre about that which can be easily quantified: the cost of the coating material the cost of the equipment and its amortization, the cost of energy to run the new system versus the energy to run the old system and direct labour costs.

6. Progress with powders continues in the metal can industry with emphasis on taste free resistant linings for beer and beverage tin free steel containers.

The chances of successfully developing ultra thin powder films which will meet the high speed application and interior lining resistant properties is still unknown. We presume, though, powder has at least an equal chance with water based linings.

4. TERMINOLOGY

Many specific terms have been used in this report for referring to various individual entities. An attempt has been made to define as many as possible where applicable and describe in broader terms existing manufacturing procedures.

4.1. Package

A package case is normally 100 tinplate sheets of any one particular ordered size.

4.2. Stillage

A stillage is a multi package unit consisting of a convenient number of packages. The maximum mass of stillage is 1 800 kg.

4.3. Thickness

Thickness is expressed in multiples of 0,01mm.

4.4. Temper

Temper is the degree of hardness or stiffness imparted to the steel base by chemical means and temper rolling and is designated by the prefix 'T' followed by a number eg. 52.

4.5. Coating Mass

Coating mass is expressed as grams per square metre and represents the total tin coating per square metre of tinplate.

'E' designates equally coated faces.

'D' designates differential coating, that is a sheet having one surface more heavily coated than the opposite.

4.6. Tinplate

Low carbon mild steel sheet coated on both sides with a very thin film of tin. The tincoating is applied by a process of electrodeposition.

A continuous coil of steel is cold rolled to the required thickness and subsequently tinned by passing it through an electrodepositing process. The tinplate is supplied either in coil form or cut into specified size sheets. Relatively low coating weights are used. This characteristic is not fundamental but demonstrates the ability of the process to distribute a coating evenly over the surface of the base plate. By the nature of the electro deposition process it is possible to produce differentially coated tinplate which is tinplate having a heavier tin coating on one surface than on the other. Electro tinning is a continuous process whereby the strip is passed as a continuous strand through all the operations of the tinning process. The mild steel basis of tinplate is very ductile and can be bent, drawn and folded into complicated shapes and is available in a range of tempers or stiffnesses. The tin coating follows to a remarkable degree the movement of the steel base and peeling of the coating from the base is almost unknown.

Steel ingots are reduced to strip (which is then cut to sheets) by the COLD REDUCTION process. The continuous cold reduction process gives flat sheets the uniform gauge with a smooth surface and good corrosion resistance.

<u>Temper Clarification</u>	<u>Fields of Use</u>	<u>Examples</u>
T1	Soft steel for deep drawing.	Drawn cans and components
T2	Shallow draws	Shallow drawn components
T3	General Purpose	Can ends and bodies
T4	General Purpose	Can ends and bodies
T5	Stiffness is required.	Large diameter components
T6	Great stiffness is required	Beer can ends

TABLE 1

QUALITY AND TEMPER DESIGNATIONS
ROCKWELL HARDNESS AND FORMING CHARACTERISTICS

QUALITY	DESIGNATION	EXPECTED HARDNESS RANGE	FORMING CHARACTERISTICS
Deep Drawing	T50	52 maximum	Ductile and suitable for reverse or multistage draws
Deep stamping	T52	48 - 56	Moderately ductile with a degree of stiffness and suitable for shallow drawn components (slip lids (crow caps)).
Ordinary stamping	T57	54 - 61	General purpose quality (ends, triple tight lids)
Ordinary forming	T61	57 - 65	General purpose quality with additional stiffness. (stiffer bodies where fluting must be avoided, ends for larger containers).
Ordinary stamping	T65	62 - 68	General purpose quality (stiff ends)
Nitrogenised steel	T70	67 - 73	Quality for very stiff ends

TABLE 1

QUALITY AND TEMPER DESIGNATIONS
ROCKWELL HARDNESS AND FORMING CHARACTERISTICS

QUALITY	DESIGNATION	EXPECTED HARDNESS RANGE	FORMING CHARACTERISTICS
Deep Drawing	T50	52 maximum	Ductile and suitable for reverse or multistage draws
Deep stamping	T52	48 - 56	Moderately ductile with a degree of stiffness and suitable for shallow drawn components (slip lids screw caps).
Ordinary stamping	T57	54 - 61	General purpose quality (ends, triple tight lids)
Ordinary forming	T61	57 - 65	General purpose quality with additional stiffness, (stiffer bodies where fluting must be avoided, ends for larger containers).
Ordinary stamping	T65	62 - 63	General purpose quality (stiff ends)
Nitrogenised steel	T70	67 - 73	Quality for very stiff ends

Steel which has been "cold rolled" is stiff and brittle. It is then "annealed" to a dead soft state. To get the required stiffness for can manufacture the steel is then "temper rolled." Here the steel is reduced in thickness by approximately 1½% to final thickness with correct temper and surface finish. Temper is measured in numbers eg. T3 or T4, which correspond to a hardness test, usually a Rockwell Tester.

5. MANUFACTURING PROCESS STAGES

5.1. Incoming Raw Material

This is the Iscor electrolytic tinplate. It is produced on a Halogen type tinning line from cold reduced, continuous or batch annealed temper rolled blackplate coils.

The steel base is normally MR type steel which is a low carbon rimming quality. Periodical elements such as nickel, chromium and phosphorous are maintained at a low level and copper is controlled to 0,20% maximum.

Temper rolling imparts the desired finish and degree of stiffness and hardness to the steel base and is designated by the prefix "T" followed by a number.

The steel base is coated with commercially pure tin. The coating mass is expressed as grams/m² and represents the total tin coating per square metre of tinplate.

- E designates equally coated faces
- D designates differential coating

5.2. Sheet Sizes

Maximum tinplate size 1090mm x 950mm. Minimum tinplate size 460 x 640mm. Minimum increments of 2mm only are acceptable. When both dimensions are less than 950mm the greater dimension will be considered as the width for pricing purposes only.

Mass Thickness Conversion

<u>Thickness in mm</u>	<u>Nominal Mass Kg/100cm²</u>
0,19	149,15
0,21	164,85
0,22	172,70
0,23	180,55
0,25	196,25
0,26	204,10
0,28	219,80
0,30	235,50
0,31	243,35
0,33	259,05
0,35	274,75
0,38	298,30

Determination of Thickness

- a) Except when determining the variation within a sheet, thickness is determined by weighing a whole sheet measuring the area and applying the formula thickness

$$(\text{mm}) = \frac{\text{Mass (g)}}{\text{Actual area (cm}^2) \times 0,785}$$

The mass of the sheet is determined to a precision of 2g and the dimensions of the sheet are measured to a precision of 0,5mm. The thickness is stated to the nearest 0,001mm.

- b) For determining the variation of thickness within an individual sheet, the thickness of each of the specimens is determined by weighing the specimen, measuring the area and applying the previous formula.

Mass Thickness Conversion

<u>Thickness in mm</u>	<u>Nominal Mass Kg/100m²</u>
0,19	149,15
0,21	164,85
0,22	172,70
0,23	180,55
0,25	196,25
0,26	204,10
0,28	219,80
0,30	235,50
0,31	243,35
0,33	259,05
0,35	274,75
0,38	298,30

5.1 Determination of Thickness

- a) Except when determining the variation within a sheet, thickness is determined by weighing a whole sheet measuring the area and applying the formula thickness

$$(\text{mm}) = \frac{\text{Mass (g)}}{\text{Actual area (cm}^2) \times 0,785}$$

The mass of the sheet is determined to a precision of 2g and the dimensions of the sheet are measured to a precision of 0,5mm. The thickness is stated to the nearest 0,001mm.

- b) For determining the variation of thickness within an individual sheet, the thickness of each of the specimens is determined by weighing the specimen, measuring the area and applying the previous formula.

5.4. Tincoating

Electrolytic tinplate is supplied with various tin coatings to suit the end use of the tinplate. The coatings are expressed as grams per square metre or by use of code letters as shown below.

TABLE 2

Coating Mass g/m ²	Code	Applications
2,8	EF	Suitable for paint containers, oil containers, general line purposes where strict anti corrosive properties are not required.
5,6	E1	Used for bottle tops, ends and lacquered/lithographed bodies. Suitable for containers where low to mild corrosion resistance is required
11,2	E2	Suitable for unlacquered containers where mild corrosion resistance is required.
16,8	E3	Suitable for milk product containers where mild corrosion resistance is required
22,4	E4	Suitable for certain unlacquered containers in substitution for hot dipped tinplate where a medium high corrosion resistance is required.
30,2	E5	Heaviest tincoating available.
<p><u>NOTE :</u></p> <p>E4 is marked with parallel lines, 76mm apart on one surface for easy identification. Differentially coated tinplate is Electrolytic tinplate having a different coating mass on each side and is available in various combinations.</p>		

5.5. Tolerances

5.5.1. Thickness

The value of the arithmetic mean should not deviate from the minimal thickness.

- a) By more than $\pm 2,5\%$ for a consignment of more than 20 000 sheets.
- b) By more than $\pm 4\%$ for a consignment of 1 500 up to and including 20 000 sheets.
- c) By more than $\pm 6\% - 4\%$ for a consignment of 100 up but not including 1 500 sheets.

5.5.2. Nominal Thickness of Individual Sheets

No sheets among those selected and measured should deviate from the nominal thickness by more than $\pm 8,5\%$.

5.6. Size Dimensions

5.6.1. Determination of Linear Dimensions

The measurements should be made on a sample sheet being laid on a flat surface. The measurement of length and width to the nearest 0,5mm should be made across the centre of the sheet.

5.6.2. Tolerances on Linear Dimensions

Each sheet in the sample should be of not less than the ordered dimensions. Normally no sheet should exceed either dimensions by more than 3mm and in no circumstances should a sheet exceed the ordered dimension by more than 5mm.

5.6.3. Sheared Sheets

Camber is the deviation of a side edge from a straight line touching both ends of the side and is limited to 1,5mm per metre.

5.6.4. Out of Square

This is the deviation of an end edge from a straight line, which is placed at right angles to the side of the plate, touching one corner and extending to the opposite side. The amount of deviation is limited to 3mm per 900mm.

5.7. Classification

Finished tinplate sheets are sorted and classified as follows:-

1. Unassorted

- a) Within size tolerances
- b) Free from pin holes
- c) 'Line inspected' only

Defective tinplate sheets are removed and primes and seconds accepted as a mixed lot.

Note :

Primes are tinplate sheets which are free from defects readily visible to the unaided eye. Seconds are tinplate sheets which may be slightly or partly defective but which are useable or partly useable.

Seconds should not exceed 15% of a complete order.

5.8. Packing

Tinplate sheets are packed in multipackage stillages mounted on wooden platforms or pallets on two or three runners depending on the size of the plate. The tinplate sheets are protected with chipboard, waterproof paper, angle brackets and edge protectors and secured by means of steel strapping.

6. MANUFACTURING OPERATIONS

6.1. Cutting

The first general step to be considered in the fabrication of a container is the cutting up of the printed or plain sheets into strips or blanks. Strips are required generally for the press component production and the blanks for the built up body production. In most factories there are two general methods of carrying out this cutting up :

- a) by guillotines
- b) by slitting machines

The guillotine is the oldest of the two methods and there are two types of guillotines -

- a) a power treadle operated guillotine
- b) a foot operated with a spring return

The machines are generally fitted with side, back and front guides or location stops. These register guides are often special in character to suit the work to be cut.

The slitting is carried out in two stages with sets of rotary gang cutting knives, the second stage feed line being set at right angles to and lower than the first.

The gauging mechanism is designed to co-incide with that on the printing and lacquering machines.

Assuming that the cutting up of the sheets can be regarded as a general operation the basic operations remain namely (not necessarily in this order)

- a) notching
- b) rolling or forming
- c) production of hooks for side seams
- d) forming or closing of side seams
- e) flanging
- 6) end seaming

6.1.1. Notching

The notching operation is that which removes material from the body blank corners to ensure that the material in the locked side seams does not extend the full length of the blank so that subsequent operations of flanging, seaming, curling and others can be carried out. One of the main influences in deciding the notch size is that of the contents the container has to carry.

6.1.2. Rolling or Forming

This is the operation to produce the cylindrical form. As a separate operation, it is usually carried out in some form of power operated pinch rolls. The body blanks are fed between two rolls and then deflected by a third roll or deflector blade. A roll is preferable so as to reduce abrasion on the blanks. It will be found at times that it is at this stage of manufacture that any variation in the quality of the plate will invariably show up as the blanks will vary in shape.

6.1.3. Automatic Side Seaming

The automatic side locker combines the two operations of edging and hemming.

This machine may be regarded as one of the most ingenious in the line machinery range. One of the greatest virtues of these machines is their universal character permitting a very wide range of work to be done on them with little or no adjustment. The diameter range starts from a minimum just a little larger than the diameter of the machine mandrel, and the maximum length handled is the working length of the forming blades. There is a limitation on the thickness of metal that can be handled.

The operations of bending up of the hooks, hooking together and accurate homing of the seam are carried out in a single sequence.

6.1.4. Flanging

Irrespective of whether the flanges are required at one end or both ends, the general methods are the same. These methods are rotary flanging in which the flange is filled up, or pressure flanging where the flange is pressed in by discs.

6.1.5. Seaming and Curling

Containers requiring the top end curled and the bottom seamed on can be dealt with in the standard type of seamer with both operations carried out simultaneously. Bodies may be curled either -

- a) Inwardly
- b) Outwardly

The outward body curl is recessed to maintain a flush, external, result and isolates the raw cut edge from the contents. Inward curls are bigger in their diameter and provide a good "lead" for lidding up.

7. A BRIEF HISTORY OF PRINTING

A recent discovery in Korea revealed that printing was invented as far back as the 8th Century A.D. A Buddhist scroll was found, measuring about twenty feet in length, and printed from twelve wooden blocks the image being Chinese characters cut in relief.

The date of the first image of moveable types for printing cannot be fixed, but it is known that the Chinese employed such types centuries before anyone in Europe.

John Guttenberg was the first European to conceive the idea of moveable types and put it into practice. This occurred in the middle of the 15th century A.D. All these printing processes were of the relief type, generally known as letterpress.

Lithography

The lithographic process was invented in 1796 by Alois Senefelder an Austrian whose actual profession was that of actor and playwright. Employment in the theatre was scarce in those days, but some of Senefelder's plays proved so successful that he decided to have them printed. Difficulties in meeting a deadline set by his bookseller determined him to become his own printer. He experimented with copper plate engraving but finding this laborious and expensive he turned to limestone. His early attempts to engrave limestone were unsuccessful, but by chance he discovered the chemical means of printing from the perfectly plain surface of the stone. Today, metal has replaced limestone exclusively. Lithographic offset printing is the process used by our company for sheet metal decoration. Robert Barclay patented the first press for this purpose in England, in the year 1875, but three years prior to this another Englishman, H.E.V. Borben was reputed to have brought the idea from France. Printing techniques are constantly changing, the most significant innovation being the use of shallow relief type printing plate. Rapid strides have been made to meet the quality of print obtainable from conventional lithographic and letterpress plates. This plate has in effect combined the two major printing processes - letterpress and lithographs and through this plate a merging of both processes with a common name will be used to produce the bulk of the world's printing.

7.1. Lithographic Printing

Name derived from the Greek - Lithos = stone

Graphic = written

Hence when Senefelder wrote on stone the word lithography was born.

The main difference between this process and other printing processes is that water plays an important part. A part which can determine whether it be good printing or bad. The process is a planographic one. The printing and the non-printing areas of the surface are on the same plane and the action which causes the printing areas to accept ink and the non-printing areas to remain free of ink is a chemical one, dependent on the well known repulsion between oil and water. Certain acids are used to form compounds on the plate - an oily acid for the ink attracting compound and a water acid for the water attracting compound.

Order of Procedure

Sketch

Reproduction

Platemaking

Sizing and Coating of metal

Printing

Varnishing

7.1.1. Sketch

Most sketches are designed in our own studios but many are supplied by the customer. Before commencing work the sketch is inspected and the number of colours needed to reproduce the design is decided. There are usually 4 - 6 colours on a coated base.

7.1.2. Reproduction

The sketch is placed on the copy board in front of the camera lens and with the use of colour fibres the various colours required are colour separated on to the negatives .

7.1.3. Filters

Blue for yellow absorbs blue, reflects green, red and yellow. Green for red absorbs green, reflects red blue and magenta. Red for blue absorbs red reflects blue green and cyan.

The camera operator can make variations from the three main colours during exposure and developing. Each colour must be at a different screen angle, otherwise all colours would be superimposed.

Wrong screen angles give mosaic patterns. After the colour separation the negatives are retouched, this gives the retoucher the opportunity of correcting the negative in its tone value. From the negative a camera screen positive is made. The retoucher can reduce the size of the dot by a process known as dot etching. The size of the dot varies the degree of colour strength.

7.1.4. Platemaking

From the film made in the reproduction the machine and proofing plates are made.

Exposures are made - the number being determined by the size of the original and the size of tinplate.

7.1.5. Printing

All modern machines are fully automatic. The tinplate is loaded into an automatic feeder and travels through the printing machine.

The principle parts of a printing machine are:

1. Feeder
2. Registration mechanism
3. Damper action
4. Inking
5. Cylinders - 1st plate, 2nd blanket, 3rd impression

7.1.6. Delivery

Very careful attention has to be given to the setting of the various mechanisms. The sheets must follow each other in perfect timing, the inking and damping rollers must be properly set and the pressures between cylinders must conform to specifications.

The operations carried out on the coating machines follow a set pattern. Viscosity is checked, stoving times and temperatures are carefully checked.

7.1.7. Feeding

If the feeder is set correctly, and also that the metal is within certain limits, good registerwork is obtained. The function of the feeder is to deliver one sheet at a time from the pile to the run in, which in turn, takes the sheet to the registering mechanism.

7.1.8. Damping

The setting of dampers to give just sufficient moisture to keep the plate clean is a very important operation. Too little water will result in the plate catching, that is taking colour on the non printing area. Too much water will gradually break down the printing area and destroy the image, especially on the fine work. It will also be picked up by the inking rollers and mix with the ink. This upsets the feed of ink to the plate and the only remedy is to wash up and start again.

7.1.9. Inks

Synthetic inks are mostly used today. The word synthetic simply means that instead of the various pigments being mixed with linseed oil they are now mixed with resins. Resin set inks are more highly concentrated and have greater improved drying qualities. A good impression is obtained with a much thinner film which also makes a good contribution for easier tooling in the manufacturing departments.

7.1.10. Inking

The objective is a good roll out. The mechanism allows for a variable supply of ink to the ink drum. The distribution by one set of rollers and the feeding of the plate by another set. The supply of ink from the duct is controlled by a ratchet and pawl action.

With the correct setting of the rollers, especially the inkers, the required ink film is obtained.

7.1.11. Printing

The actual printing is from three cylinders. plate, blanket and impression. The plate is first rolled by the dampers to supply the moisture; the inking rollers follow, leaving a fresh film of ink on the image. The plate then comes in contact with the blanket, transfers the image to the blanket, which in turn offsets the image on to the metal.

7.1.12. Stoving

The machines are fitted with travelling ovens, either gas, or oil fired. The principle is that the hot air is kept in constant circulation and the printed sheets on the move.

This obviates the possibility of burning.

The ovens are thermostatically controlled and all the variations in temperatures are made by use of the controls. Ovens used in the metal decorating industry can be considered to have four major functions.

1. To raise the temperature of printing sheets of tinplate to a specified baking temperature in the shortest possible time.
2. To exhaust the volatiles driven off from the decorative materials applied to the sheets.
3. To maintain the sheets at the specified temperatures for a given time.
4. To cool the sheets to a temperature low enough to permit handling, automatic stacking and re-running of the sheets. All conveyor type ovens are similar in as much that individual tinplate sheets are carried by a roller chain conveyor through a tunnel formed by insulated metal panels which enclose the baking section. Wickets or sheet supports are permanently attached to the conveyor chains and hold the sheets in a vertical position as they travel through the baking and cooling sections. The conveyor chains are continuous and travel around sprockets at the front and rear of the oven. In the oven itself the chains are supported on tracks which must be in absolute true alignment, otherwise excessive wear and rough running would result, which in some severe cases would give rise to marking off the decoration. The pitch of a conveyor chain usually determines the spacing of the wickets attached.

7.1.13. Varnishing and Coating

Although this operation is outside the lithographic process it is a very important part of our business. The varnish has a three fold purpose; it gives a finish to the decoration, acts as a protective coat against the atmosphere and handling, and assists in the manufacturing. Viscosity and film weight checks are taken out at intervals. This also applies to size, base coatings and lacquers.

7.1.14. Lacquers

a) Reasons for Use of Lacquers

1. Internally : to reduce interaction between metal of container and pack.
2. Externally : To prevent atmosphere corrosion.

b) Essential Properties - Internal

1. Ability to form a resistant film after stoving.
2. Ability to withstand forming operation without excessive damage.
3. Ability to withstand heat of soldering without excessive damage or scorching.
4. Comparative freedom from flavour.
5. Freedom from toxic elements.
6. Ability to withstand contact with food under conditions of processing.

c) External

1. Ability to withstand forming operations without excessive damage.
2. Ability to withstand all commercial processing conditions and to resist mechanical damage during processing.

8. DEVELOPMENT BACKGROUND

At the commencement of this development, MB technical department was provided with an indication of the range of products which should be powder coated.

As a large percentage of the products were round built up components and were consequently almost impossible to powder coat in the finished state we opted to develop a system which would withstand the metal deformation normally encountered in can making. A great deal of development work has been carried out with encouraging results.

However, if we are to convert this success into a production reality further development work will be required.

9. REPORT ON UP TO DATE RESULTS

A pilot plant has been built comprising a single electrostatic spray gun and powder feed system, electrostatic grounding and an infra red curing system. All components of the system are working well and a sound understanding of the theory and operating principles has been achieved.

Joint work with powder suppliers has resulted in a clear powder being available which will withstand, without breakdown the deformation common in hardware manufacture.

Problems still exist on the curing side as tolerances have to be established which will eliminate discolouration of designs resulting from the different absorption characteristics of various colours. This aspect of different absorption characteristics for different colours has been seriously considered and we have recently decided to try and induce radiant heat on the underside of the substrate whose colour characteristics are identical or of one colour and ink film thickness.

Not all the results have been positive. Input from further research now indicates that an additional characteristic that of air flow through the oven would be helpful. Solvent removal in the initial stages of the oven could be greatly enhanced with the addition of more air volume and velocity at the oven's initial stage. This air movement was not felt necessary in the original oven design.

The control systems as they presently exist provide heating energy strictly based on line speed and a variable intensity required for a particular stock. In all cases this control has been proved to be more than adequate. With the advent of high quality optical pyrometers an additional feedback loop can easily be added to the control scheme. This feedback is based on shell temperature at the oven exit.

By adding control based on temperature a more realistic power level is set for the actual line conditions.

A proposal to provide this input into the control scheme is presently being considered.

9. REPORT ON UP TO DATE RESULTS

A pilot plant has been built comprising a single electrostatic spray gun and powder feed system, electrostatic grounding and an infra red curing system. All components of the system are working well and a sound understanding of the theory and operating principles has been achieved.

Joint work with powder suppliers has resulted in a clear powder being available which will withstand, without breakdown the deformation common in hardware manufacture.

Problems still exist on the curing side as tolerances have to be established which will eliminate discolouration of designs resulting from the different absorption characteristics of various colours. This aspect of different absorption characteristics for different colours has been seriously considered and we have recently decided to try and induce radiant heat on the underside of the substrate whose colour characteristics are identical or of one colour and ink film thickness.

Not all the results have been positive. Input from further research now indicates that an additional characteristic that of air flow through the oven would be helpful. Solvent removal in the initial stages of the oven could be greatly enhanced with the addition of more air volume and velocity at the oven's initial stage. This air movement was not felt necessary in the original oven design.

The control systems as they presently exist provide heating energy strictly based on line speed and a variable intensity required for a particular stock. In all cases this control has been proved to be more than adequate. With the advent of high quality optical pyrometers an additional feedback loop can easily be added to the control scheme. This feedback is based on shell temperature at the oven exit.

By adding control based on temperature a more realistic power level is set for the actual line conditions.

A proposal to provide this input into the control scheme is presently being considered.

10. RESEARCH AND DEVELOPMENT

10.1. Objective of Research

The objective of this paper is threefold.

- a) to review the basic phenomena associated with powder coating.
- b) To describe the main applications of powder coating.
- c) To describe some of the ways in which recent research has provided information which may facilitate control of the quality of polymer coatings using electrostatic powder coating and examine their ability to act as a protective film when sprayed onto decorated tinplate and then formed into shaped products.

10.2. Scope of Development

To promote knowledge, stimulate research, generate standards, definitions, specifications and recommended practices for the development of physical, chemical and electrical methods of testing powder coating materials and curing same.

10.3. Analysis of Each Phase

- | | |
|-----------|----------------------------------------------------------------|
| Phase I | Definitions and literature |
| Phase II | Physical properties of powder coating materials |
| Phase III | Applications and film formation properties of powder coatings. |
| Phase IV | Physical properties of powder coating films. |
| Phase V | Safety |

11. DEFINITIONS

11.1. Powder

A coating powder is a finely divided organic polymer of a thermoplastic or thermosetting type which may or may not contain pigments, fillers and additives remaining finely divided during storage under suitable conditions.

11.2. Powder Coatings

A protective and/or decorative coating formed by the application of a finely divided polymeric material with or without pigment to a substrate and fused into a continuous film by the application of heat.

11.3. Historic Factors

The idea of thermosetting powder coatings originated prior to 1960 when Shell laboratories in Delft Holland and co-incidentally Libert Freres, a relatively obscure paint company in Ghent, Belgium were looking at new products. *

Libert Freres saw the potential of epoxy powder and began development, compounding the epoxy resin into a commercially acceptable paint alternative. In 1965 Libert Freres started marketing epoxy powder under the trade name Oxyplast and have watched acceptance grow at a phenomenal rate. By the end of 1971 licensees and distributors had been established in 30 countries, with manufacturing plants in U.K., Japan, Canada R.S.A., Australia, New Zealand, Spain and Finland. The choice of epoxy material for the coating was most fortuitous since the properties are so phenomenal that at long last industry had a coating which would do almost everything without the inherent disadvantages of the solvents in present paints. When industry began to use the materials dry, many more advantages were discovered making the process even more attractive.

11.4. Powders

Powder coating is the process of melting polymeric powders to form a continuous film over the substrate usually metal. The powders may be composed of thermosetting or thermoplastic polymers.

Thermosetting powders are those which cross link or polymerise when stoved to a non convertible film. Thermoplastic powders on the other hand, merely flow into a continuous film and will re-flow on heating.

Thermoplastic Powders

P.V.C.

C.A.B.

Nylon I

Nylon 6

P.V.C.

Polypropylene

Thermosetting Powders

Epoxy

Polyester

Acrylic

Epoxy/C.A.B.

Epoxy/Polyester

Polyurethane

We are going to concern ourselves with thermosetting powders only, because these are the nearest to the conventional stoving enamels used in the bulk of the finishing industry.

There are at the present time within the fields of thermosetting powders four basic types of resin systems to be considered without delving too deeply into the ramifications of mixed monomers and they are :-

Epoxy, polyester, polyurethane and acrylic.

A brief discussion about these main systems would initiate an attempt to place them in some sort of perspective for the tentative powder user.

11.4.1. Discussion on Powders

Powder is not a paint or coating until the coated item emerges from the curing oven. Prior to baking it is a finely pulverized plastic composition. Consequently the manufacturer of powder coatings is more closely related to plastics processing than paint manufacturing. This unique feature, paint, from plastic equipment has had a major impact on the properties and overall quality of powder coating resins.

The resins needed for powder coatings are quite different from those used in paints. Whilst paints require low viscosity, low molecular weight resins which are soluble or miscible with solvents and/or water,

Powder coatings require resins which are solid at room temperatures but then melt sharply to a low viscosity for both ease of processing and the achievement of smooth high gloss finishes. Powder coatings therefore start with resins which, by paint standards are well along in their cure. In addition, the molecular weight and polymer structure must be tightly controlled so that the melt temperature and melt viscosity are within very narrow limits to ensure processability through melt mixing equipment.

Powder coatings are now available in a broad range of generic groupings.

Generic classification is used as a convenient guide to the various powder coatings in use today, but is not an exact defining parameter. Powder coatings similar to liquid coatings are custom formulated to meet specific end use requirements. Additives, modifiers and resin blends are used to achieve the balance of properties needed for certain applications. Therefore, within each generic group properties can and do vary widely.

Quite often more than one generic type of powder coating can be custom formulated to meet these needs. The final choice must be arrived at through co-operation and compromise between the powder supplier and the user.

11.4.2. Thermosetting Powder Coatings

a) Epoxy Resin Based

The epoxy family of powder coatings is the most prominent type of thermosetting powder in use today. This listing of available epoxy formulations is quite extensive because of the wide formulating latitude that exists. These materials consist of epoxy resins, catalyst system, re-inforcing fillers, pigments processing aids, flow agents and other modifiers. A change in the type or the amount of any one of these constituents can noticeably change the properties and performance characteristics of the product. Epoxy powders are used for both functional and thin film decorative applications. The functional epoxies are in use in a wide variety of corrosion protection applications. While many formulations offer about the same resistance, certain formulations are better suited for specific conditions due to differences in toughness, flexibility, impact resistance, vapour permeability and temperature stability.

The particular application defines which of the many variations best meets the overall requirements. There are a broad number of functional epoxy powder coating types available, generally classified as :

Filled	-	Rigid
Unfilled	-	Flexible
Normal cure	-	Semi flexible
Fast cure	-	Normal cut through
Ultra fast cure	-	High cut through
Normal flow	-	Normal edge coverage
High flow	-	High edge coverage

There are several classifications as to particle size for the application method -

1. Fluidized bed grade (200 - 300 micrometers)
2. Electrostatic powder grade (25 - 250 micrometers)

Typical applications are -

Automobile alternatives
Watt hour meters
Printed circuit boards
Battery cases
Bus bars
Gas distribution pipes
Irrigation pipes

11.4.3. Thin Film Decorative Epoxies

In designating this group of epoxy powder coatings as decorative it is not meant to infer that the protective qualities are in any way reduced, but only that the initial and lasting decorative qualities of the finish are a major consideration.

The inherent toughness, corrosion resistance, flexibility and adhesion of the epoxy family coupled with the control of gloss, flow texture and colour make them ideal for many decorative applications in the 25 - 75 microns film thickness range.* Epoxy powder coatings are generally custom formulated to the specific decorative and performance requirements of a given end use.

With the latitude now available the formulation has control over :

Environmental Properties - such as salt spray resistance, chemical and solvent resistance, temperature stability, thermal shock and humidity resistance.

Decorative Properties - such as exact match of colour, gloss and texture with batch to batch uniformity.

Mechanical Properties - such as hardness, flexibility, impact, chip and scuff resistance.

Customer Plant Conditions - such as cure time, edge coverage and film thickness.

Typical Applications

Fire extinguishers, microwave ovens, glass bottles, office furniture.

11.4.4. Epoxy Polyester Hybrid

This group of powder coatings would be considered part of the epoxy family except that the high percentage of polyester utilized makes that classification misleading.

Property wise, however, these hybrid coatings are more closely akin to epoxies than polyesters with a few notable exceptions. They show similar flexibility in terms of impact and bend resistance, but are slightly softer in pencil hardness, H-3H being characteristic.

Their corrosion resistance is comparable to epoxies in many cases, but their resistance to solvents and alkali is generally inferior.

A major advantage of these hybrids due to the influence * of the polyester component is a high resistance to overbake yellowing in the cure oven. This also translates to improved weatherability : these solvents will begin to chalk almost as fast as an epoxy but after that, the deterioration is slower and the discoloration less severe. Another advantage of the epoxy polyester powder coatings is extremely good electrostatic spray characteristics. They have excellent transfer efficiency and penetrate well into corners and recesses.

Economically they are comparable to epoxies and therefore are used where a slight improvement in application efficiency heat stability and weathering are required.

11.4.5. Polyester Resin Based and Acrylics

The polyester powder coatings combine outstanding thin film appearance and toughness with excellent weathering properties. They are true competitors to high quality liquid paints, exhibiting superior chip and scuff resistance at 35 microns thickness.*

Typical applications are :-

Fluorescent light fixtures

Patio furniture

Fence fittings

Chrome wheels and trim

Transformer cases

The acrylics have never really achieved significant commercial success.

They demonstrate good electrostatic spray properties making the application of low film thickness realistic and controllable.

12. POWDER APPLICATION METHODS

There are three primary methods of applying powder coatings, electrostatic spray, fluidized bed and electrostatic fluidized bed. The best process for a particular application depends on a number of factors; such as -

- purpose of the coating
- coating thickness and thickness tolerance
- size and shape of the parts to be coated
- rate of production
- material handling techniques

Table 3 presents a generalised picture of the processes and their applicability to various types of parts and industries.

TABLE 3

POWDER COATING APPLICATION METHOD	Coating Thickness Microns	Type of Coating			Type of Parts			INDUSTRY					
		Decorative	Protective	Functional	Pipe & Tube	Sheet	Wire	Appliance	Automotive	General Mfuf.	Lighting	Hardware	Container
ELECTROSTATIC SPRAY	25 - 500	X	X	O	X	X	X	X	X	X	X	X	X
FLUIDISED BED	250 - 500	O	X	X			X	O	O		O	X	
ELECTROSTATIC FLUID BED	25 - 75	X	O		X		X	O					X

TYPICAL ROOMMATE ALTERNATIVE ROOMMATE SYSTEM

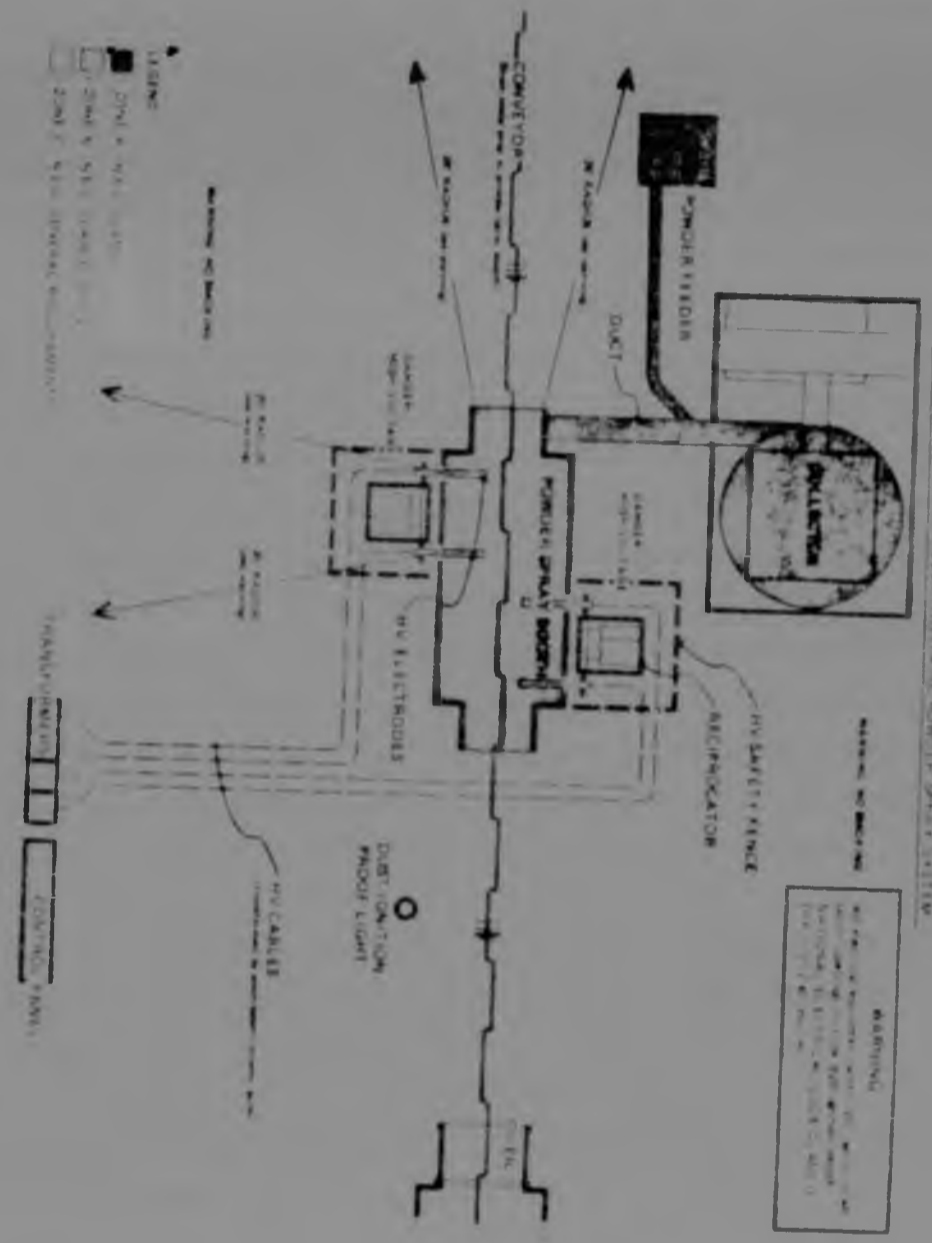

LEGEND
 200V AC
 200V DC
 200V AC

WARNING
 ALL ELECTRICAL WORK MUST BE DONE BY A QUALIFIED ELECTRICIAN. DO NOT ATTEMPT TO REPAIR OR MAINTAIN THIS EQUIPMENT UNLESS YOU ARE A QUALIFIED ELECTRICIAN.

TYPICAL AUTOMATIC ELECTROSTATIC POWDER SPRAY SYSTEM

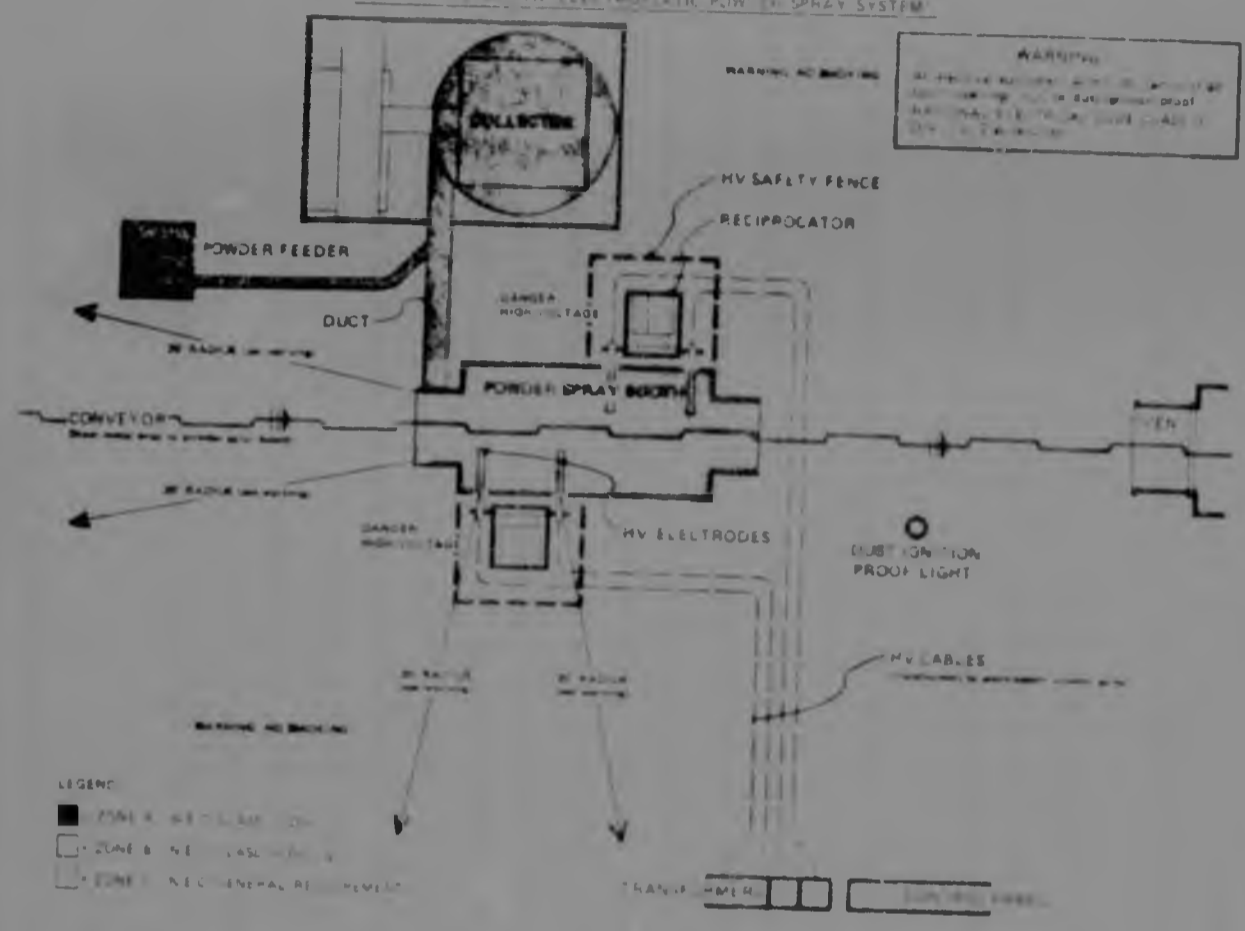

12.1. Electrostatic Spray

It can be seen from the table that the electrostatic spray process is the most versatile and flexible application process. The basic electrostatic spray process employs spray guns to apply powder to the part. The guns may be manual or automatic. Powder is delivered to the guns through flexible tubing from a supply hopper.

At the guns the powder is charged electrostatically, usually with a negative charge of from 50 to 100 KV. The guns also establish an electrostatic field between themselves and the workpiece. The workpiece is at ground potential. The like charged particles repel one another but are attracted to the grounded workpiece. Build up of powder on the workpiece is controlled by the number and arrangement of the guns, their powder output and spray pattern and the speed of the conveyor carrying the parts. Film thickness can be monitored at the desired level by adjustment of these factors and the electrostatic charge put on the powder. Sprayed parts are carried directly to a bake oven where the powder adhering to the part melts, flows and fuses to the surface, forming a continuous thermoset film. Deposition efficiency depends greatly upon the configuration of the parts, but from 40% to 60% is normal in many applications (figure quoted by users).

However, the overspray is not lost. Several techniques are used to reclaim the oversprayed powder for re-use and material utilisation can approach 100%.

Air exhausted from an electrostatic spray powder booth serves three functions.

1. It maintains the powder air concentration below the minimum explosible concentration of the powder.
2. Flowing into the booth through its several openings it keeps powder from drifting outside the booth.
3. It begins the powder recovery process.

Because of their great surface area per unit volume, each organic powder has an explosion potential based on a specific range of concentrations of powder in the air. The lower end of this range is known as the minimum explosible concentration (MEC).

In order to keep powder from drifting out of the booth, it is further recommended that air flow into the booth through its openings average at least 30 metres per minute. This booth exhaust is based either on this value or that called for to maintain 50% of the MEC whichever is greater.

The third function of the air flow through the booth is to begin the recovery process. In the most common recovery method the oversprayed powder is carried along with the air exhausted from the booth through a series of ducts to the dust collection equipment which separates the powder from the air stream. The dust collection equipment may be a cyclone, a bag filter, or a cartridge filter.

Filters recover almost 100% of the oversprayed powder.³¹ Cyclones are used generally in multi colour systems because they can be cleaned and are 85% - 95% efficient. Cartridge filters are becoming more widely used than bag filters because they provide greater filter surface and efficiency in the same space as a bag house. Air exhausted from the dust collector is returned to the plant, usually through an absolute filter which removes any submicron particles that may pass through the primary recovery unit.

The moving filter belt is a modification of this basic powder recovery technique. * An endless belt of process fabric similar to that used for filter bags forms the floor of the spray booth. Booth exhaust air passes through the belt into a plenum beneath but the powder is separated from the air stream by the belt. The filtered air is exhausted into the plant, again through an absolute filter.

The belt carries the powder to the end of the booth where it passes beneath a vacuum pick up head. The powder is vacuumed from the belt and recovered from the vacuum air stream in a small cyclone or cartridge filter.

A recently introduced variation of the filter belt is the filter drum. In this case, the filter fabric is mounted on a perforated cylindrical drum which rotates in the bottom of the spray booth. The principle of the operation is the same. The filter removes the powder from the exhaust air stream and a vacuum head removes the powder from the rotating filter medium.

12.2. Automatic Recycle Equipment

There are two basic systems for recycling of the oversprayed powder based on the type of collection system used. When a filter belt is used, the oversprayed powder is vacuumed off the belt and transported to a cyclone cartridge collector. From there it is gravity fed into a sieve through a rotary valve. From the sieve it is gravity fed into the powder feeder. The virgin material is also vacuumed out of the powder drum and pumped into the same gun feeder. The second system uses venturi pumps to transport the powder from the bottom of a cartridge collector or cyclone to a vibrating sieve which gravity feeds into the gun feeder. These same pumps will pump powder out of a drum into the sieve and mix the virgin powder with the reclaimed powder before it enters the gun feeder.

12.3. Fluidised Bed

The fluidised bed was the original technique used to apply powder coatings more than twenty years ago. Powder in the bed is kept in a constant state of suspension by means of compressed air introduced from a plenum beneath the bed. The parts to be coated are preheated and then passed through the bed of suspended particles. Those particles coming into contact with the heated surfaces partially melt and adhere.

The fluidised bed is probably the simplest method of powder coating. No recovery system is required as the powder not deposited on the part remains in the bed. However, it is difficult to produce films thinner than 200 microns.

Thus the fluidised bed is limited primarily to applying coatings that are protective or functional.

12.4. Electrostatic Fluid Bed

A variation of the conventional fluid bed employs electrodes in the bed to charge the suspended particles. Parts to be coated are grounded and are carried over the top of the bed. The charged particles are attracted upwards to the grounded parts. One of the difficulties with this system especially with parts having a significant vertical dimension is uneven thickness of the coating. Film thickness tends to be greater at the bottom than at the top.

However, the electrostatic fluid bed is widely used to coat thin parts such as tubing, wire and wire screening which can be carried across the bed continuously. As in the conventional fluid bed no recovery system is necessary.

13. SYSTEM DESIGN

The extent of surface pretreatment for a powder coating line depends upon the substrate, the type of powder used and the nature of the application. The essential requirement is that the surface be clean free of dirt, oil grease, oxide coatings and other contaminants. Grit blasting may be used when relatively thick films, 125 microns or more are applied as protective or functional coatings. Phosphating is normally required for optimum results with thinner coatings. Pre-treatment is usually followed by a dry off oven and then the parts are usually allowed to cool down to ambient temperature before entering the powder application section. Thermosetting powders do not require a liquid primer. Most thermoplastic powders do.

NOTE :

Within our own Company two options avail ;

1. To powder coat the decorated tinfoil.
2. To powder coat sized or white coated tinfoil and then store this quantity and print the stock according to orders issued.

In case (1) no pre-treatment would be required since the tinfoil would be coming off a dry-off oven. In case (2) most probably pre-treatment would be required in order to alleviate any problems that would be generated from storage conditions.

14. CURING

Powder coating lines and ovens require no flush off space. The coated part proceeds immediately from the spray booth to the bake oven. Oven temperatures and curing times depend on the part and the powder.

As powder contains few volatiles, the parts need not be brought to temperature gradually but can be subjected to high heat immediately. Thus a powder oven can usually be smaller than an oven used to bake a liquid paint. Curing temperatures are usually higher than for liquid paint systems. However, low temperature cure powders are beginning to appear on the market place. Coating powder seldom contains more than 2% volatile organic compounds, compared to at least 20% and frequently 70% for liquid paints.*

Thus oven exhaust rates can be lower than with most liquid coatings. As fluidised bed application systems are relatively straight forward and simple, we will concern ourselves primarily with electrostatic spray application. The application section of an automatic powder coating system consists of the coating booth, and powder recovery system plus the equipment and controls required to charge the powder and spray it on the parts. Generally the electrostatic spray equipment, spray guns and reciprocators will be of standard design. The major consideration is to select the best equipment for the application. Powder coating spray booths are almost completely enclosed. Openings are provided only for guns, for entry and exit of the part, for hangers and for powder recovery. Maximum enclosure improves powder recovery efficiency and system cleanliness.

Spray guns can be positioned on both sides of a powder coating booth. Also in an automatic system, touch up can be accomplished in the same booth. Thus only one booth is required for the entire job. Tests are necessary to determine the optimum design of an automatic system. The primary object of the tests is to determine the number of guns to be used, their position and spray patterns and the extent and rate of reciprocation and the optimum conveyor speed. Usually it is better to use several guns at moderate output rather than to force high output from a few guns. Lower output promotes higher deposition efficiency and reduces overspray.

Individual control of voltage, air pressure and powder feed rate to each gun provides maximum flexibility in designing a system for optimum results and economical powder consumption. A narrow jet is usually used to penetrate holes and recesses. Lower voltage may also be desirable for recesses and optimum voltage may vary among guns coating various portions of the surface.

Broad fan patterns are better for coating large flat areas. The general configuration of the spray booth is determined by the size of the parts, the speed of the conveyor, the number of guns and their arrangement. Slots for reciprocating guns should be sealed with a flexible membrane to prevent powder from escaping from the booth and also to minimize air flow into the booth through the openings.

Air rushing through these openings can disturb the spray pattern and reduce deposition efficiency. Both sidewalls should be smooth and free of projections or ridges on which powder could collect.

15. COMPARISON OF E/S AND FLUIDISED BED TECHNIQUES

The advantages and disadvantages of both techniques as mentioned below are of utmost practical importance. A general idea is given of which process should be used in any special case. No doubt a general answer is not possible because both techniques do not sufficiently overlap. The most important points were collected during several discussions with more than fifteen consumers.

15.1. Advantages of E/S Compared to F.B.

1. Thinner coatings possible (less than 100 microns).
2. Thinner substrate can be used (even metal foils)
3. One surface coating possible.
4. Small amounts of powder are sufficient to initiate spraying.
5. Lower oven temperatures, which means less expense.
6. Coating costs per square metre are lower.

15.2. Disadvantages of E/S Compared to F.B.

1. Thin coatings are not always desirable.
2. Recollecting system necessary, otherwise high powder losses.
3. Longer coating cycle.
4. Difficulties coating corners (Faraday cage)
5. Equipment more expensive.
6. Increased danger of dust explosion due to finer grain size.
7. Production changes requires longer preparation.

16. POWDER - RAW MATERIAL

Powder is a product in which the various particles are distinct from each other and which must stay so to permit application. It is a product which is HETEROGENEOUS, which means that the various particles whilst being of the same kind, differ in their size and shape. Now, in the case of an electrostatic application of powder, the various phenomena which occur (electrical charge, action of the transport air current, contact with the materials forming the equipment) take place at the level of the elementary particle, and not on the powder as a whole. On the other hand, the product to be applied is an organic product whose characteristics are affected by the surrounding conditions. In particular, it melts when the temperature is raised and forms clogs when placed in a humid atmosphere

This product is generally very insulating. It can be electrically charged by rubbing, and keeps a great part of its charge even in contact with an earthed metallic wall. One must distinguish the elements not specific to powder application (manometers, transformers resistances, transistors, electro valves), for which the equipment manufacturer should give his best care in the choice, and the elements specific to powder application (spraying nozzles, dosing and transport devices) for which a thorough study is necessary in their conception and realisation.

The reliability of such system incorporating so many variables is a function of the compulsory control of the interactions between the product to be applied and the various elements of the equipments operating under the surrounding conditions of the application.

16.1. Powder Preparation

Powders intended for application by electrostatic spray are usually prepared by melt compounding together all of the ingredients in the formula and then grinding the final homogeneous mixture to a fine powder. The processing of such a powder is shown in the following block diagram

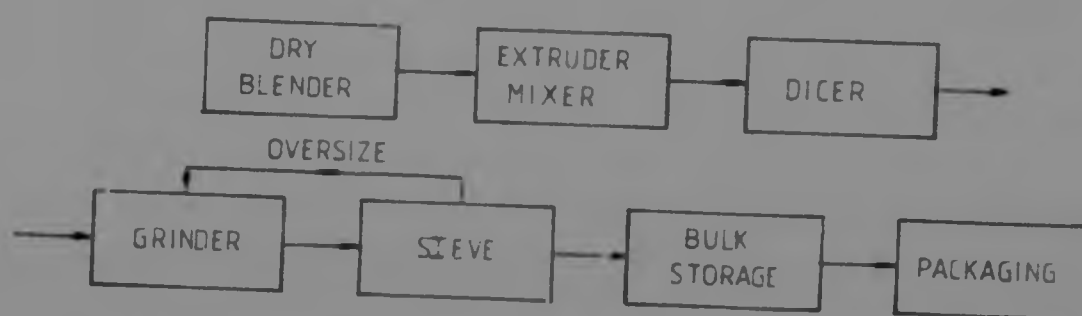

In this process all the ingredients for the formula, resin pigments, plasticizers, stabilizers etc are mixed together until reasonably homogeneous. The mixed ingredients are fed to an extruder. Here the resin is melted and intimately mixed with the other ingredients to produce a uniform compound that is then extended. This is cooled and chopped into small pieces on the dicer and these are then ground in a suitable mill to the particle size needed for spray application. The value of this technique as opposed to the dry blending method often used to manufacture vinyl powders for fluid bed application lies in homogeneity of the powder. Since all ingredients are bound together in each particle, there is no opportunity for segregation of ingredients to occur. In cases where pigment is used it is completely dispersed and its colourant and hiding characteristics are developed to the utmost. Overspray frequently can be collected and re-used with only a simple screening to remove large aggregates. The grinding operation is easily accomplished with brittle low molecular weight resins such as epoxies. When higher molecular weight resins are employed such as vinyls, polyethylene etc an ordinary hammer mill will be inadequate. These polymers are too tough to be shattered in the mill at room temperature.

However, if they are cooled to a very low temperature they can be readily ground.

Cryogenic grinding has been under active study for some years now. After intensive effort a cryogenic pulverising system has been developed which meets the requirements of low operating cost, low capital investment, safety and flexibility. Extensive use is made of polyurethane foam insulation to minimise frost formation and maximise liquid nitrogen efficiency by reducing heat losses.

16.2. Shelf Stability of Powders

This is a major criteria for powders. Package stability can be characterised in several different ways.

16.2.1. Sintering

This is the mechanical properties of the powder to agglomerate and fuse under conditions of heat and pressure. The molecular weight and the glass transition temperature of the basic resin are the controlling factors here.

Materials can be so poor that they will form a solid block under some storage conditions.

16.2.2. B-Staging

This is the chemical property of the material to cross link, in the powder form, under conditions of heat. It is a gradual change in which the texture of the applied coating can be observed to increase as the B-staging progresses. The powder will eventually turn inert leaving a totally unfused film.

The controlling factor is the resin/curing agent combination. If the system is made too reactive problems in this area result. This is the major deterrent to low-temperature fast-cure materials.

16.2.3. Moisture

Certain resin/curing agent combinations form a hygroscopic compound. In these compounds, water is readily attracted and can :

- a) negatively affect charge acceptance and transfer efficiency.
- b) free acid from the curing agent which initiates B - staging.
- c) negatively affect free powder flow properties.

17. ULTRA THIN FILM APPLICATION

Penetration of powder coatings into the container coating field has been deterred by the inability to achieve continuous coatings in the 5 - 10 microns thickness range with appearance and performance properties equivalent to conventional solvent based coatings.

Most companies working in this area have concentrated on the formulation aspects to achieve the required appearance and properties but the minimum film thickness necessary for continuous coverage was greater than 40 microns.* This thickness was limited by the rather coarse particle size of 35 - 55 microns obtained by hammer type milling which would not flow sufficiently to provide adequate film continuity and appearance at lower film thicknesses. In recent tests, we have demonstrated the feasibility of obtaining continuous powder coating films with desirable properties at film thicknesses competitive with conventional solvent based points by reducing the powder particle size to about 10 microns.

Fluid energy pulverizers are able to reduce the particle size of powders to about five microns by impacting particles in a stream of gas. Very fine powders such as this are usually highly agglomerated and tend to spew when applied in the normal fashion. These agglomerates can be broken up during transfer from the powder storage chamber to the object by increasing the air velocity to the gun.

This is an effective technique that can be used in the laboratory but may not be applicable to many commercial installations. In this latter case an improvement in the free flowing characteristics of the powder would most probably be the ultimate answer.

To date the best results with ultra thin films have been achieved with jet milled powders.³ Powders prepared in an extruder and pebble milled to an average size of 15 microns (maximum size 40 microns) have shown some promise but because of the comparatively large particle size, film appearance and film continuity at low film thicknesses were not as good as that found in jet milled powders.

Another approach being investigated to prepare ultra thin film powder coatings involves by-passing the extrusion step altogether and grinding the raw materials directly in a jet mill. Powders prepared in this manner have given encouraging properties, but an extensive evaluation of the finished powder in terms of particle segregation and powder stability will be required before this approach could become commercial.

18. FORMULATION PROBLEMS

The first epoxy resin powders were intended for use as heavy duty coatings providing a high degree of chemical and abrasion resistance in films of 200 - 250 microns. Very little attention was paid to appearance and gloss provided the film was free from pin holes and tightly adherent. However, the chief uses of powder coatings are in fact in decorative applications in films of only up to 60 microns where film appearance is at least as important as chemical resistance. Formulation for decorative purposes gives rise to problems which are considerably different from those found with stoving paints containing solvent.

Figure 1 shows the course of the processes which occur when an epoxy powder is stoved in an oven at 200°C. It is a scan from a differential scanning calorimeter in which the sample is heated from room temperature to 200°C at a rate of 64°C per minute and then held at 200°C (Research Inc U.S.A. provision).

Movements of the trace in a positive direction represent endothermic readings and movements in a negative direction exothermic reactions. At point A the system is absorbing heat strongly as the resin melts and the powder begins to form a coherent film. When point B is reached the system begins to exotherm as the resin and curing agent react and this exotherm reaches a peak at point C. Thereafter cure continues until the trace becomes horizontal or the stoving cycle ends at point D. Thus the total film formation including coalescence, substrate wetting and flow out has to take place in the period between A when the resin melts and C when the system gels. Film formation is substantially complete by the time the article reaches the nominal stoving temperature.

However, this is not the complete story since flow is also dependent on the viscosity of the system while it remains molten. This is illustrated in Figure 2 where lines of equal viscosity are shown against time and temperature.

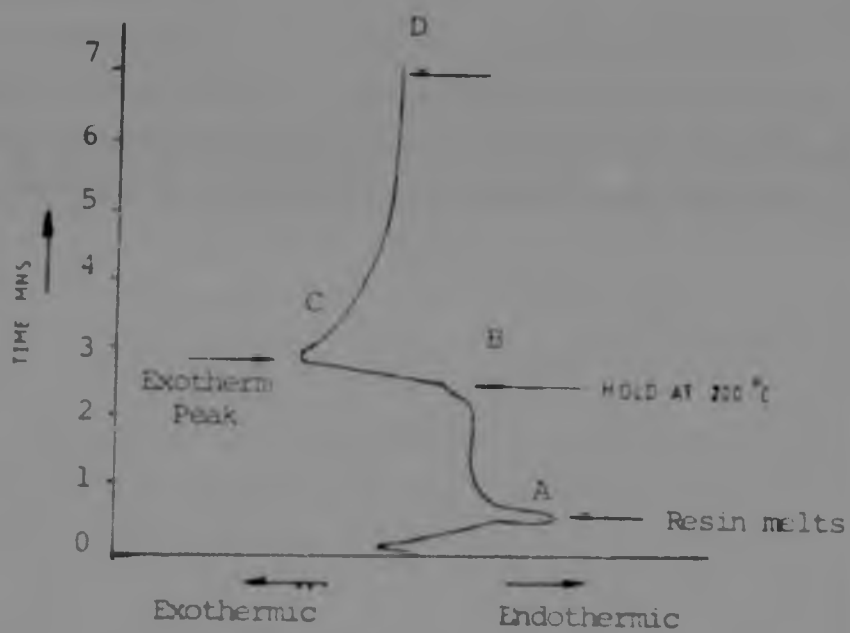

Figure 1
Trace from differential scanning calorimeter.
Temp ° C'

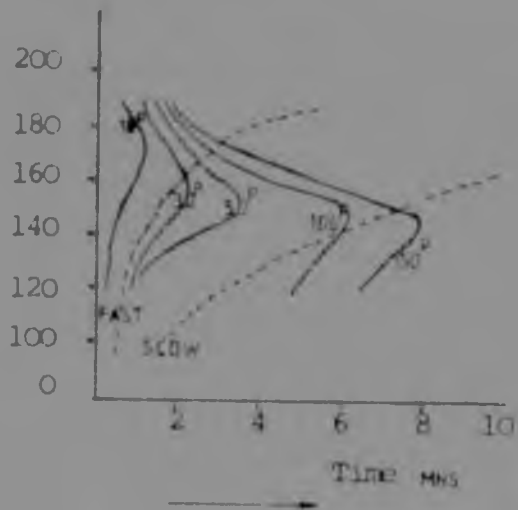

Figure 2
Viscosity contours for powder coatings

Here it can be seen that a balance must be struck between a low rate of heating which gives a long period in the molten state but always at a high viscosity and a high rate of heating which provides a low viscosity but only for a short period.

For preference the bend width of heating rates in which adequate flow is obtained should be as wide as possible to allow for differences in oven loading. It is against this background of constraints dictated by the process of application that we can consider problems of formulating for specific applications.

Here it can be seen that a balance must be struck between a low rate of heating which gives a long period in the molten state but always at a high viscosity and a high rate of heating which provides a low viscosity but only for a short period.

For preference the bend width of heating rates in which adequate flow is obtained should be as wide as possible to allow for differences in oven loading. It is against this background of constraints dictated by the process of application that we can consider problems of formulating for specific applications.

19. FACTORS AFFECTING POWDER CHOICE

Cost is one of the most important considerations and the emphasis here should be on total cost. It is not always apparent that there is a difference between the price per Kg of a powder and the applied cost. It might well be that a slightly more expensive powder will give a better return in terms of improved coverage and flow at lower film thicknesses. Equally, it is not worth choosing the relatively more expensive powder types for an application which does not require the highest decorative appearance and outdoor durability.

Although the range of finishes in all the main thermosetting powders has been extended and improved beyond all recognition in the last few years, the epoxies still offer the widest choice of decorative effect. Naturally, when considering the range of powder available the properties of the cured film must be well defined in order to select the most suitable material.

19.1. Physical Properties

- Flexibility - bend test
- Adhesion - cross hatch
- Resistance to damage - Scratch and impact test
- Resistance to heat - Non yellowing

19.2. Chemical Properties

- Solvent resistance
- Salt spray and humidity resistance
- Water soak
- Resistance to chemicals
- Stain resistance

19.3. Outdoor Durability

- Corrosion resistance
- Chalking
- Fading, loss of gloss

9.4. Curing Requirements

Temperature, time, fuel, convection, radiant, induction curing.*

Powder Curing Schedule

Curing Schedule

Standard cure epoxy	180°C for 10 - 12 mins
Low cure	130°C for 15 - 20 mins
Fast cure	180°C for 5 mins
Polyester	190°C for 8 - 10 mins
Polyurethane	190°C for 10 - 15 mins
Acrylic	200°C for 15 - 20 mins

20. CURING OF POWDER COATINGS

Having selected and applied a suitable powder, it must now be cured, preferably before vibration or air impingement cause dust or contamination from foreign materials.

Unfortunately the technology for accomplishing this is not as well recognised as are the other steps in the selection and application of powders.

On a simplified basis, the cure cycle requires rapid heating to fuse the particles to one another, and to the product itself. This can be accomplished by pre-heating the part to fixing temperature before the powder is applied, or by post-heat after powder application, or a combination of both.

While the post-heat method is more conventional, pre-heating offers advantages for heavy mass products, and usually requires less total energy.

21. RADIATION CURING

Abstract

Radiation curing technology brought new life to the coating and ink industries due to the energy crisis and strict rules and regulations for air pollution.

A technique was developed in the last decade known as radiation curing. This section of the study will compare the advantages and disadvantages of electron beam, ultraviolet and infrared curing systems against conventional air dry or baking systems. The role of oligomers, monomers, photoinitiators or photosensitizers are discussed.

Film properties such as stability, colour of cured films and handling are considered.

Introduction

Energy, ecology and environmental considerations brought the opportunity for innovation and development of a new curing technique to ease these crises.

When this new technique, known as radiation curing, is applied in the coating or ink industries, it is generally referred to as EB, UV and IR curing. One can define radiation curing as "the use of radiant energy from any portion of the electromagnetic spectrum for the curing process".

The mechanism and cure rate of radiation induced reaction on the intensity of the incident radiation, the absorbance level of the energy acceptors and quantum yield. The penetration of radiation into a material depends on the nature and energy of the radiation and on the type of interactions that occur between the absorber and radiant energy.

21.1. Photocurable Resins

When a formulator designs a photocurable resin, various components must be considered²⁻⁷

21.1.1 Oligomers Generally are low to medium molecular weight mono or multifunctional unsaturated materials. They may include acrylated polyesters, acrylated polyurethanes and acrylated epoxy compounds which provide the primary properties of the cured film such as high abrasion resistance, high tensile strength, elongation, good solvent resistance and acceptable levels of hardness and flexibility, and also compounds having reactive groups which when properly sensitised can initiate polymerisation by photolysis, e.g. BF_3 complex can split by UV light and will cure epoxy resin by cationic polymerisation

21.1.2 Reactive Diluent Usually are mono or multifunctional acrylates. These materials act as viscosity reducers and can vary the degree of functionality, thereby varying properties such as flexibility, hardness, toughness, brittleness and adhesion.

21.1.3 Photoinitiators and photosensitizers. Absorb the impinging light and induce polymerisation.

Radiation curing systems may also contain flow control agents, non-reactive polymers of relatively low molecular weight, additives for stability, adhesion, agents and pigments.

Some organic pigments act as catalysts yielding undesired polymerisation and reduction of shelf life. Therefore, pigments should be chosen very carefully. Heavily pigmented coatings are cured without difficulty by using electron beam.

21.2 Advantages and Disadvantages of Radiation Curing Systems Over
Conventional Curing Systems

21.2.1 Advantages

- (1) Using 100% polymeric materials, radiation curing reduces air pollution and safety hazards are minimised compared to solvent based coatings and inks.
- (2) Operating speeds are much faster, therefore higher production speeds are attainable.
- (3) Space requirements needed are much less compared to conventional gas fired ovens.
- (4) There is no degradation of the product due to excessive drying and heating. The equipment is kept at room temperature which permits the use of heat sensitive substrates.
- (5) The consumption of energy is roughly 1/5 for UV and 1/100 for EB compared to solvent based coatings and ink systems.
- (6) There is no solvent retention in the coating, hence there is little possibility of pinholes in the films.
- (7) There is a reduction in manufacturing steps, storage and scrap loss.
- (8) EB curing systems can cure through an opaque material, such as in laminating foil, paper or plastic to another material..

21.2.2 Disadvantages

- (1) Capital investment for EB curing equipment is higher than for conventional type systems.
- (2) Finished product formulation prices are higher for UV and EB curing products.
- (3) UV curing materials may reduce shelf life over conventional curing materials.

21.3 Radiation curing process by UV and EB

The radiation curing process forms an active free radical generated by radiant energy which initiates free radical polymerisation.

In EB curing, high velocity electrons, when applied to the organic molecule, penetrate the material and form free radicals. The UV curing process needs a photoinitiator or photosensitiser to form free radicals. An electron of an organic molecule is attacked by the electron beam and promoted to antibonding orbitals of high energy or is removed from the molecule. Then the molecules are excited or ionised.^{1,2,3}

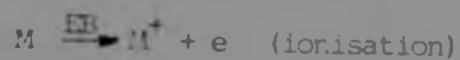

Generally, ionised molecules are changed to the excited state through neutralisation and another reaction also takes place:

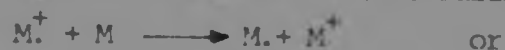
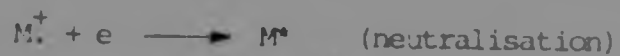

Usually neutralisation is preferred over the other two. Then excited molecules decompose to various radical species $M^* \longrightarrow R + R'$

In the UV process, a free radical is induced in the following



The radical polymerisation involves the usual ionisation propagation, and termination processes.

21.4 Infrared

The range of IR wave lengths forms a large part of the electromagnetic spectrum including short, medium and long wavelengths. It is extended from 760nm to 1 mm and an energy range of 37,6 to $28,6 \times 10^3$ Kcal/mole. respectively. It means that short and medium wave radiation have high energy levels and they produce greater intensity while long wave radiation gives less intensity.

(Ref. Bibliography).

Therefore, short and medium wave IR imparts higher heat than long wave IR.

When organic molecules absorb IR radiation, atoms or groups in the molecule vibrate and rotate faster. These molecular motions increase the internal energy of the absorbing mass, therefore, physical and chemical phenomena change which lead to what we describe as curing.

The drying mechanism of the current IR inks is not clear but ink films will absorb the necessary amount of IR energy to complete the polymerisation reaction in the presence of catalysts.

Short wave IR, because of its penetrative power into the substrate produces enough heat to accelerate drying by usual oxidation phenomena. Long wave IR lacks such penetration and only surface drying of ink is possible with very much longer dwell times.

22. HIGH VELOCITY OVENS

High velocity ovens offer great flexibility and considerable advantages in a powder coating system.

To appreciate these advantages is to understand its design and operation. High velocity ovens are often referred to as high impingement ovens indicating that air is directed at and across the coated cure at a comparative high velocity and in a large volume. This, of course, is a function of design.

Air is directed into plenum chambers and pressurised to a static load of approximately 100 mm water column.

Depending on the product being processed, the plenum chambers can be located on the sides, top, bottom, or any combination thereof. These chambers contain a pattern of air nozzles or knives from which the air is expelled toward the product load.

Air nozzles usually protrude into the oven enclosure but may be recessed or flush with the plenum walls. The heat source or energy in high velocity ovens may be natural gas, propane, oil, electric, or steam. A large percentage of air (90%) is recirculated and reused, thus injecting a high degree of economy in its operation. The recirculated air is passed over or through the heating media where it is reheated and elevated to the required temperature.

It is then directed by a high temperature form or goes through distribution ducts into the plenum chambers from which it is again expelled from the nozzles or air knives.

One of the outstanding advantages of high velocity is its ability to reduce curing cycles. Shorter curing times reflect a reduced floor space requirement for baking equipment offering a considerable saving as compared to a standard box type convection oven.

Shorter curing cycles are a direct result of the high velocity principle of rapid heat transfer to the product substrate metal

temperatures and not ambient or surface temperature must be considered.

High velocity air directed at the product breaks through the normal insulated air boundary that surrounds it and continues to "bombard" it with the required elevated fusing temperature. While so doing, it removes the cool insulative barrier that slows down the baking time cycle. In the standard low air movement type oven longer fusing cycles are necessary due to the lengthened dwell or soak time required to bring the substrate up to the required melt, flow and fuse temperatures.

Other advantages of the high velocity principle are:-

- (a) Less conveyor required. Because high velocity ovens are used in a continuous flow system only the amount for the oven length is necessary. This is opposed to a convection type in which the product is serpentine back and forth or passed through a very long space to obtain the required "dwell" time to permit a proper time and temperature cycle to achieve a cure.
- (b) Reduced installation costs. Due to modular one piece construction ranging from 3 to 15 metres.
- (c) Rapid oven bring up time.
- (d) Precludes powder overbake. May be inexpensively electrically conveyor overlocked to automatically shut the oven off or turn it down to a pilot setting upon conveyor stoppage.

The reverse effect of rapid heat transfer which is "cool down" takes place by the recirculation of air allowing the coated parts to cool to a point below where overbake and degradation can occur.

High velocity ovens are generally designed for the specific product being processed. This configuration therefore allows the oven to accrue the maximum benefits and economies possible resulting in quality, efficiency and many economies for the user.

23. POST HEAT SYSTEMS

Post-heating may follow partial pre-heat or may involve the full temperature elevation indicated. In either case it is essential to co-ordinate heat delivery to the coated product with:

- (1) Available oven exposure time
- (2) Actual product or cure temperature required
- (3) Mass and thermal conductivity of the product.

If convection heating is to be employed for fusing the powder, high air velocities are normally required to attain needed heat transfer rates as it is essential to remove the cold air film adjacent to product surfaces following heat release. This prevents hazards as to drift and non-uniform cure results.

Alternatively, radiant heating can plasticise powders in less than one minute.

The energy level which is controllable in the oven is adjusted up or down to the desired cure level by confirmed measurement from a radiation pyrometer. Zone 1 of the oven thus satisfies the primary temperature build while Zone 2 serves to replace heat losses and energy conducted into the product for temperature equalisation. For the one who can justify an individual oven for each type or part to be processed, the control may be simplified but the heat transfer problem remains the same.

This brings up the question of suitability of existing liquid paint baking ovens for curing powder coatings.

In a typical coating laboratory where development work is normally carried out on small panels that do not present the complex heating problems of plant production, a circulating convection oven with air temperature control may be adequate for comparative studies, but this does not apply to ovens that must handle large and small products varying from light to heavy foils.

For example a well designed oven for liquid coatings normally provides low heat delivery for an initial 2 or 3 minutes of product exposure, to assure a smooth paint film free of pinholes, blisters and orange peel effect. Faster heating rates may follow with higher air velocities to complete the bake cycle.

This "low to high" sequence of heat release to the coated products is precisely in reverse to the "high to low" sequence needed for reliable fixing of powders.

A more suitable approach to the conversion of any existing paint oven to a powder cure oven is the simple addition of an infrared booster section at the load entrance, or fuel manifolds supporting radiant gas burners may be installed within the existing oven enclosure.

These can be connected to the premixed fuel system originally used to supply the convection burner system.

24. FLOW AND CURE PROPERTIES

The transformation of the powder from a granular state to a cross-linked film involves subjecting the powder to various degrees of heat treatments. These heat treatments can be both isothermal and non-isothermal.

It is desirable to have a deeper insight, both quantitative and qualitative, into the mechanisms whereby a thermosetting powder progresses through a molten flowing state to a cured film.

A technique to provide such insight is provided by differential scanning Calorimetry (DSC). (This technique was described and provided by Research Inc., U.S.A. after discussions and trials on MB's panels and powder used.) The principle of a differential calorimeter is to measure the heat flux required to maintain an equal temperature in the sample and a reference.

(See graph)

A typical scan of any epoxy powder is shown in figure 3. The vertical axis shows the difference in heat flux required to maintain the sample at the reference temperature. On the horizontal axis the temperature is proportional to time, depending on the heating rate used. In the early part of the scan the baseline is steady indicating that the powder is absorbing or releasing heat at the same rate as the reference.

The first deviation from the baseline is endothermic that is heat absorbing, and is superimposed as a baseline shift. The deviation occurs at a temperature which is the glass transition point of the resin, designated by T_g .

A further baseline shift occurs after the point T_{of} which marks the onset of flow. The divergence from the baseline occurs at T_{oc} and is strongly exothermic.

After/...

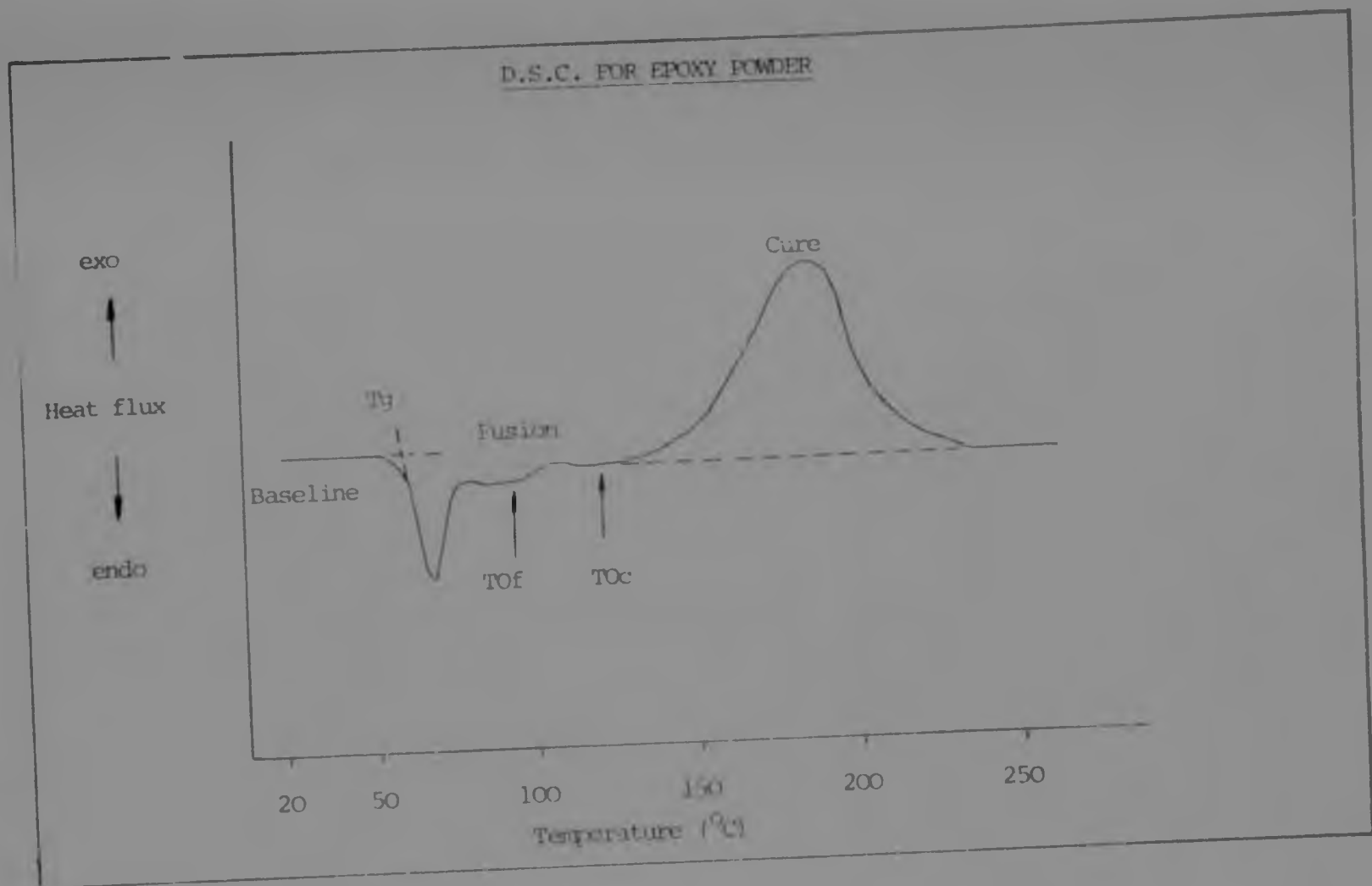

Figure 3

After the exotherm reaches a maximum, the output of heat decreases as final cure is achieved.

The scan shown was carried out on a powder at a heating rate of 40°C/minute.

From the temperature of the sample the time of heating can be calculated. The heating time in minutes is shown beneath the horizontal temperature axis. It can be seen that melting, flow and curing took place within a period of minutes. Varying the heating rate will expand or contract this time span.

Increasing the heating rate will result in a contracting so the time between TO_f and TO_c will be reduced or the period of flow will be reduced. Conversely a decrease in heating rate lengthens the time of flow before curing starts. The longer flow time would tend to produce a coating with a smoother finish. The situation is not so simple, though, since the lower temperature associated with a longer flow time also means that the viscosity of the molten resin will be higher than if a higher heating were used. In order to select the optimum heating rate, one needs knowledge of the viscosity of the resin at various stages of the stoving schedule.

25. MELT VISCOSITY

The melt viscosities of powder coatings at various temperatures under the influence of varying heating rates can be determined using the Hook Rotovisco instrument^{12,13}.

The melt viscosities of an epoxy powder formulation versus time for various temperatures are shown in Figure 4. Transforming this information to a temperature/time relationship we obtain a contour map showing lines of equal viscosity, as in Figure 5.¹³ It is apparent that the heat-up rate of the oven must be such as to provide a compromise between a slow rate which gives a long period in the molten state, but at a high viscosity, and a fast rate which provides a low viscosity but only for a short period.

The terms of fast and slow heat-up rates can be translated into terms of types of substrates for an oven of constant heat-up rate. The fast heat-up has been found to correspond to the thinner substrates whilst the slow rate to a thicker substrate.

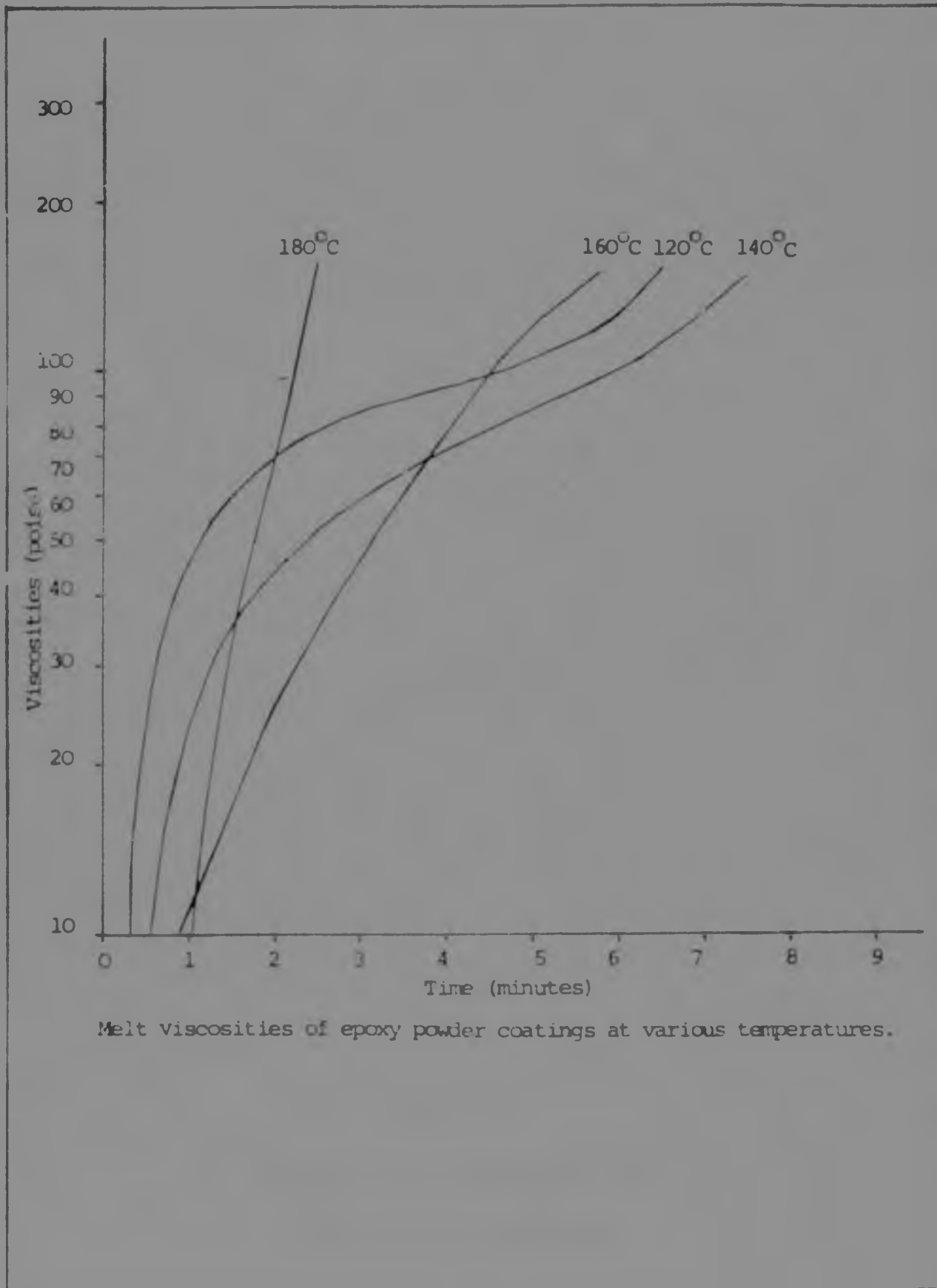

Figure 4

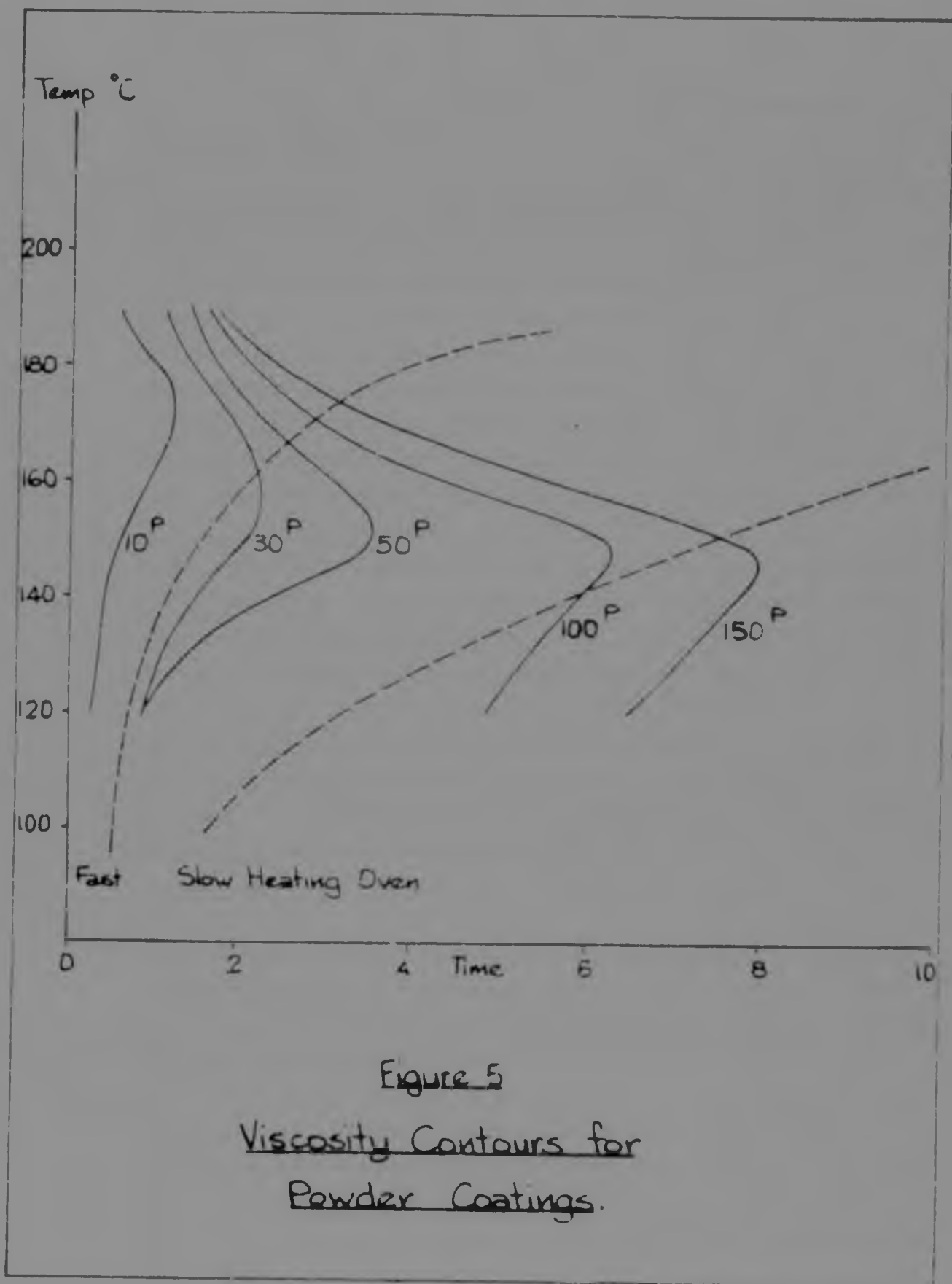

Figure 5

Viscosity Contours for
Powder Coatings.

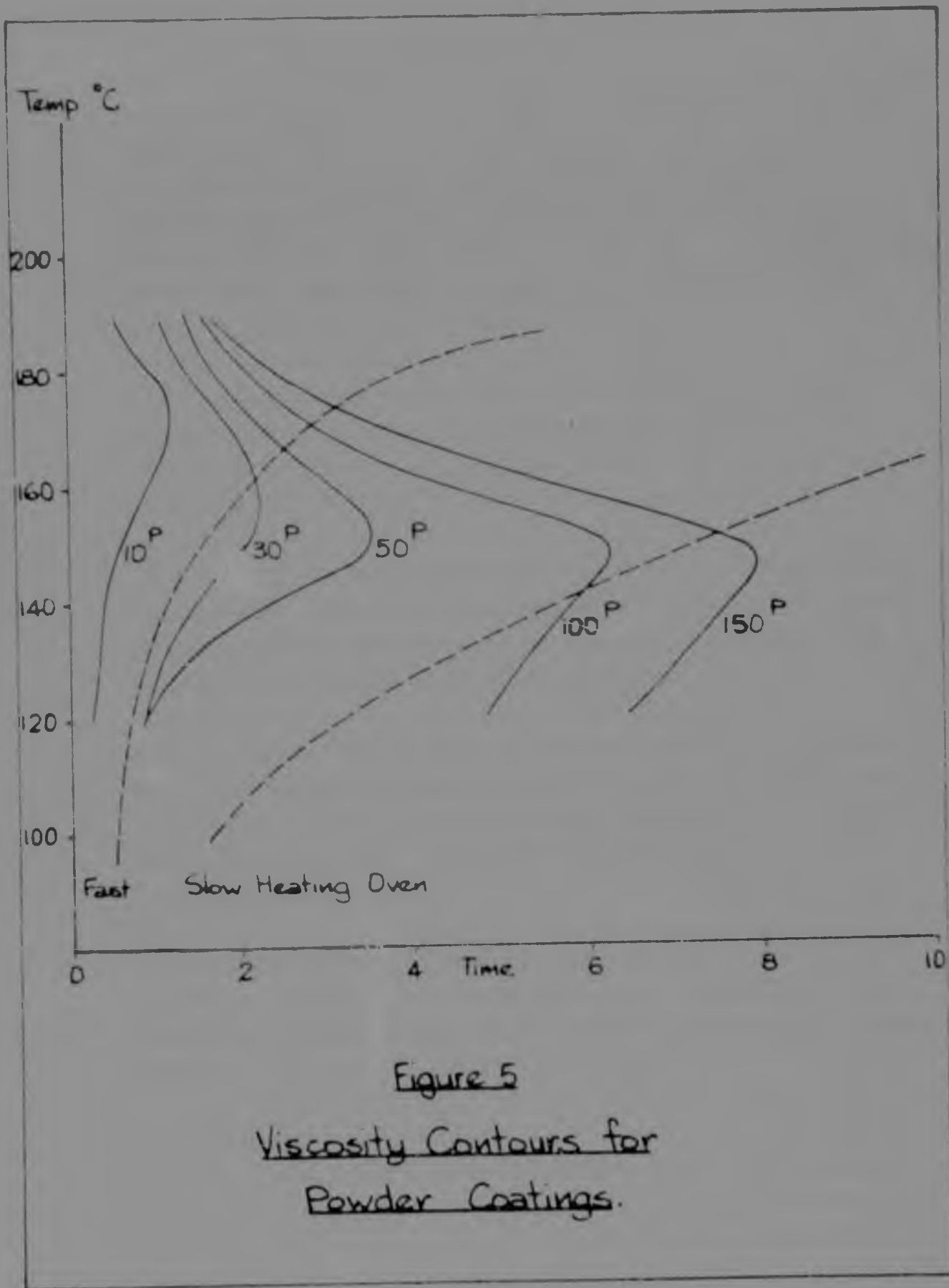

Figure 5
Viscosity Contours for
Powder Coatings.

26. INFRARED - CURE FOR POWDER

Among the inherent advantages available, the characteristic of fast heating probably comes first. This fast heating is relative to a conventional convection oven. We say relative to convection because under some circumstances a high velocity convection oven can be as fast as, or faster.

Infrared ovens raise surface temperatures to cure range within seconds, after the product enters the oven. This is the time saving phase because temperature maintenance, for a specified time to cure a finish, is usually the same as a convection oven. Because infrared is fast, process time is substantially reduced permitting shorter ovens. Shorter ovens mean less floor space as well as reduced conveyer length. Most infrared ovens are modular, or made up of many panels of the same type which more or less conform to product shape.

These modules are lightweight sheet metal construction which are easily suspended overhead releasing even more floor space. Being modular in nature most ovens can be conveniently extended, or re-located, should production requirements change. (App. 11)

Because product bring-up time is short, and most oven suppliers embody the modular approach, first cost is very competitive. A comparison of quotations within our company between infrared and convection ovens show a savings of 30% to 40% of the cost of a convection oven.

No more than a minute, or less, is required to bring the oven to operating temperature. This fast heat-up and cool-down can mean significant savings in time and the start of production, or rejects because of over-cure should the line go down.

The infrared characteristics outlined above are related directly to heating with radiant energy rather than convection, or conduction, although these types of heat transfers do influence which products and circumstances enhance or deteriorate the radiant heating mechanism.

Radiant heating is direct and does not involve any intermediate between the heat source and the work.

In view of the heating mechanisms utilised with infrared, several application characteristics were predicted. First, product heating with infrared is a function of the area exposed to the radiation and the weight of the product to be heated. Since radiant energy is converted to heat at the surface of the product, unexposed portions are heated by conduction or convection. The heating rate of unexposed areas is a function of the heat conductivity of the part, or temperature of the air coming into contact with the exposed surface. Infrared radiation is absorbed most readily at exact right angles to the surface of the product. As the angle of incidence becomes greater, the heating effect becomes less and less until the surface is parallel with radiation travel. In this case the heating effect is quite reduced.

The intensity of the radiant energy diminishes as the distance is increased between the product and the heat source and follows a specific rule. Given a certain hypothetical value of intensity of radiation 200mm from the source, that intensity will fall to 1/4 the original value if we move to 400mm from the source. Most parts baked in any infrared oven should be approximately the same size. If not, small parts may not reach proper temperature and conversely, large parts may overheat from being overexposed to the heater source. If the product has hidden reinforcements or support pieces attached to the heated surface, the attachment interface conducts heat away. Extended exposure is required here to overcome the heat sink effect. Identical shapes made of different substances reach different temperatures in the same oven. This is due to the specific heat of the substance involved. Colours also affect the temperature attained. For a predetermined heating cycle, black will attain a higher temperature than will white. In short, product uniformity is essential. Curing a finish involves bringing the entire part to the required temperature.

There is such a thing as 'skin effect' where the finish applied and only a small depth of the substrate is brought to curing temperature. Although a highly desirable situation, it is sometimes difficult to attain. With most sheet plates, heat conductivity of the metal is so high the entire product attains curing temperature.

The coating on the product affects heating (an uncoated product heats much slower than a coated one) so it plays an important part in the heating process.

Take for example, an applied liquid coating of approximately 40% to 50% solids. A portion of the infrared energy that strikes the coated surface passes through the liquid film. We are assuming that unpigmented areas of the film which contain only resin and solvent are transparent to the infrared energy. In any case, that portion of infrared passing through the film strikes the substrate and is reflected back into the film and aids in bringing the liquid film to temperature. As the film gains heat, some of the heat is conducted to the substrate over the interface and the product itself begins to come up to temperature. The paint film and the interface are soon at cure temperature and the cycle concludes. Adhesive qualities of the film are preserved because the substrate was at the proper temperature.

Consider the same product but with a dry thermosetting film applied almost 100% solids. In a cross section view, we can visualise the substrate with several layers of powder particles of various sizes attached to the surface by electrostatic forces. Since the powder particles totally obscure the substrate, no infrared reaches it. As the powder film absorbs radiant energy, the exposed layer of powder particles begins to plasticise and conduct heat to particles below and finally to the substrate.

If circumstances are right, the substrate will gain enough heat through conduction to reach cure temperature about the time the powder film cures and solidifies. In this instance, film adhesion is intact. If the hot plasticised powder did not stay in the liquid stage long enough for the substrate to come to temperature, then adhesion would be very poor.

While we could fairly accurately predict many circumstances, we felt it was in our own best interests to verify these predictions. We believe infrared curing with powders has excellent potential, but is relatively uncharted. At this juncture, we probably will not sell our finished items without some more solid test, Research work.

OUTLINE OF BASIC PROCESS

27.1 Scope - this outline intends to establish an understanding of the typical powder coating system if the development of the study is to be followed.

27.2 Process - the basic arrangement in a typical powder coating system is shown in Figure 6.

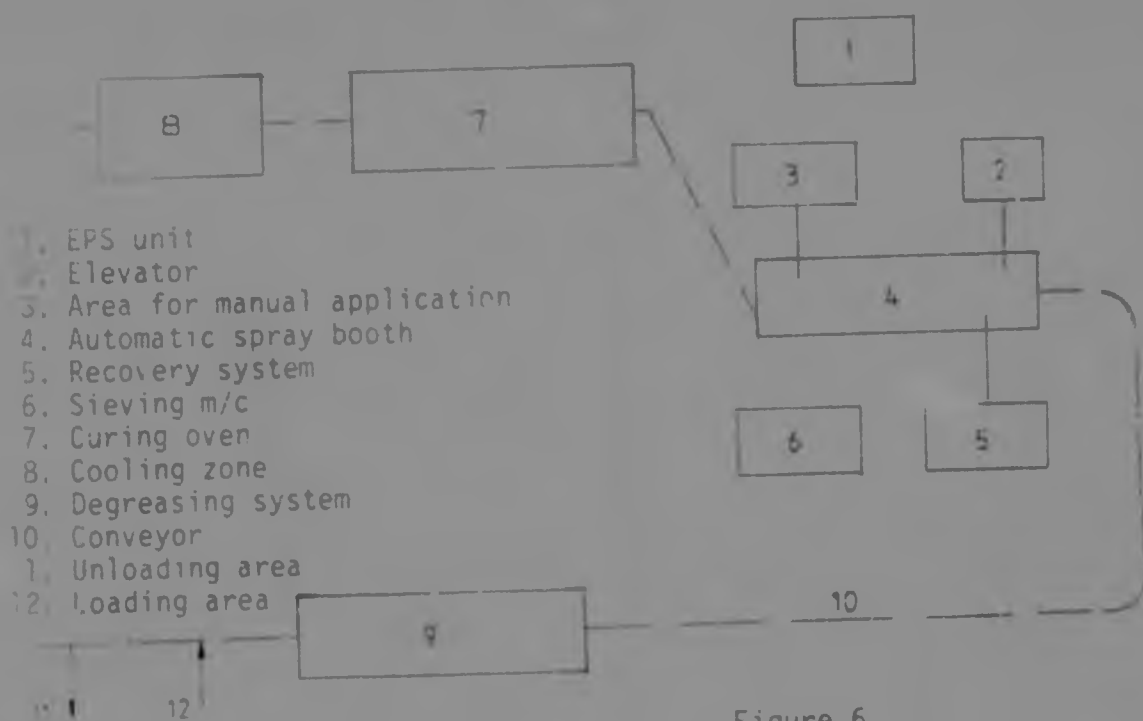
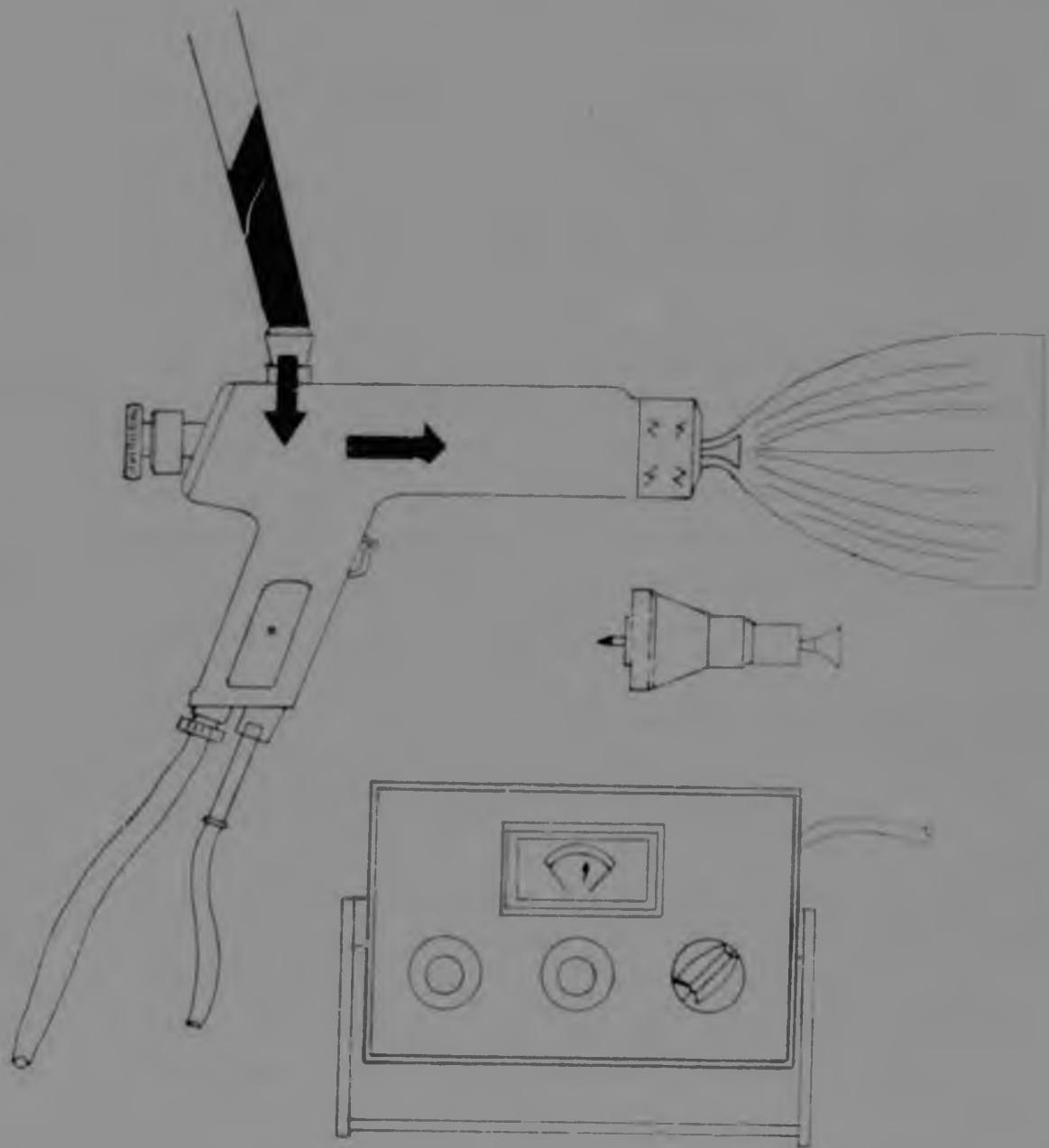
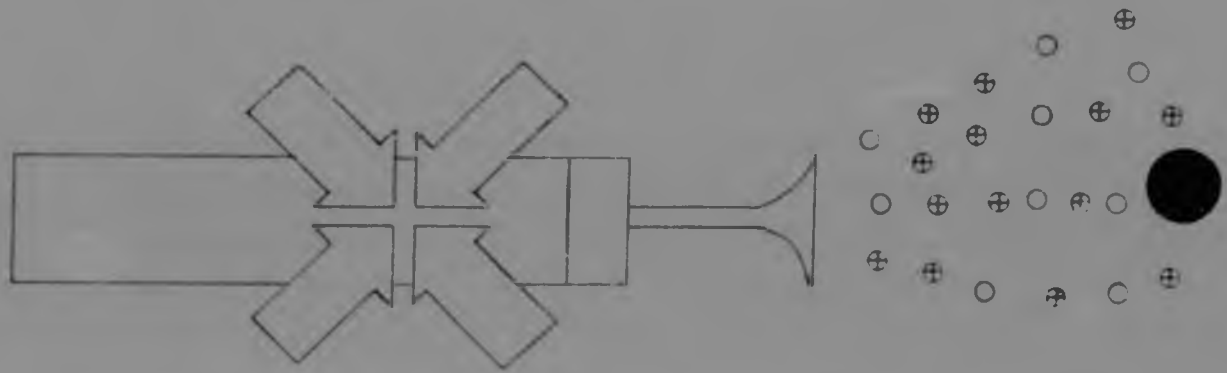

Figure 6

The powdered coating material is fed to the gun and charged in the nozzle region.

The charged powder then moves towards the earthed object under the influence of the electric field between gun and object. The powder is held by electrostatic forces to the surface of the substrate. The article is subsequently heated in an oven, where the unfused powder layer melts to give a continuous film. It is found that the nature of the unfused powder layer has a profound effect on the properties and physical nature of the fused layer. In any coating system,

ELECTROSTATIC GUN



there are four distinct classifications of importance. These are: conveyor, coating booth, bake oven and spray equipment. The success of the system depends upon the effective integration of these components. The basic equipment for electrostatic powder coating consists of a spray-gun, a powder container, a spray booth with powder recovery and a curing oven. Electrostatically charged powder is sprayed towards a grounded metal article. The charge is imparted at the head of the electrostatic gun to the powder where it exits at a very low velocity so that the electrostatic field will convey the powder to the article. The feed system for most powder guns is a hopper and air Venturi system.

The powder falls down into the Venturi wall to be picked up by the stream of air through the system. It then flows to the head of the gun through a hose or tubing. Air pressure to the venturi and the hose diameter determine the flow-rate.

The process for electrostatic powder coating is similar to that for electrostatic lacquering, the difference being that instead of varnish, a powder is used which is fused together by heat, spread and then hardened on the workpiece. As no solvents are required in order to maintain the material in a liquid condition, there is very little contamination of the environment by this procedure.

Upon careful inspection the considerable differences between electrostatic wet coating and electrostatic dry coating become apparent.

In the case of wet lacquering, an electric field is required to save lacquer, in that the sprayed and electrically loaded lacquer particles follow the lines of the field and are attracted to the workpiece, to which they adhere. This is done solely to avoid losses due to overspraying.

In the case of powder coating the electric charge of the sprayed powder particles is used for the adhesion of these particles to the workpiece. Although it is desirable that as many particles as possible are conducted towards the workpiece, it is not too important, in that the oversprayed particles can be easily recovered and re-used. The problem with regard to the Faraday screen is also minimised as those particles adhering to the workpiece have a repelling effect on subsequent particles as soon as a certain coating thickness has been obtained ensuring a sufficient coating of the parts which were initially not easily accessible.

It is here that we find the most striking difference in the spraying techniques employed, namely coating of less accessible parts. This factor must be mentioned here, as the quantity of oversprayed material plays an important part in safety techniques and as there is obviously an inverse relation amongst spraying efficiency, spraying evenness and penetrative capacity in Faraday screens.

27.3 Types of components

We must make a basic distinction between the coating of cold, metallic workpieces, of pre-heated workpieces and of cold or pre-heated hollow pieces.

The first group can be described as classical and pure electrostatic powder coating. The remaining two fields of application must be mentioned in this context as electrostatic spraying is also used and no clear division is possible. The most varied field of application is the coating of workpieces with blank metallic surfaces which are coated at a temperature of between approximately 15°C and 30°C. Depending on the powder used, a dry coating thickness of 30-150 microns can be achieved with grain sizes of between 3 and 100 microns. *

In the case of the second group, the workpieces are pre-heated to approximately 200°C-300°C to obtain a greater coating thickness, as the sprayed powder then immediately fuses onto the workpiece. In this instance an electrostatic application is not strictly required as adherence is achieved through the fusing process.

However, by using electrostatic spraying equipment a particularly even distribution is achieved within the jet itself and on the workpiece, which results in a very smooth surface and of course a regular coating thickness. Pipes for pipelines, sheeting, strips and wire grating are usually treated by this method. As adhesion is brought about by fusion non-metallic materials can also be coated by this process. In the USA this is used in particular for glass bottles to reduce the danger of breakage. The last group comprises hollow pieces, such as tubes or containers for which a special coating procedure is employed.

As the spray cloud inside a hollow piece is particularly prone to the danger of ignition, this procedure is permitted only if special safety measures are taken, such as for example the use of gas instead of air or a very low powder spray concentration.

27.4 Powder coating equipment and procedure

A description of the required techniques must go hand in hand with the description of the procedure.

The workpiece cycle starts at the conveyor, then goes onto the pre-treatment process to the adhesive solution dryer and finally to the spraying chamber. At this point the workpiece cycle is tangential with the powder cycle. After leaving the powder spraying chamber the workpiece is transported to the dryer for hardening and then to the collection point. The powder cycle commences with the infeed of the powder into the

powder preparation equipment. From here the powder is transferred to the powder dosing machine and then to the powder spraying unit. The powder spraying unit sprays the powder inside the previously mentioned chamber from where any excess powder is extracted to the powder separator.

This recovered material is then transported back to the powder preparation equipment, where it is intermixed with the freshly fed-in powder.

The powder spraying chamber consists always of a housing with inlet and outlet openings for the workpiece and for hand operated chambers there may be a large opening in front of which the hand-operated coater is mounted, or only a small slot through which the spray gun is directed.

On the floor on the side of the chamber are suction apertures through which the oversprayed powder is sucked out together with the air entering the chamber through the holes mentioned above. The floor on the chamber is usually designed in such a way that no powder will settle on it, but that it will be drawn towards the suction apertures. Such floors are either hopper shaped, prism shaped or fluid floors.

Fluid floors consist of a porous plastic base through which air is fed from beneath to avoid the powder settling on its surface. The powder will thus flow on the very slight slope towards the suction aperture.

28. SYSTEM DESIGN CONSIDERATIONS FOR OPTIMUM EQUIPMENT UTILISATION
IN POWDER COATING

In any system for powder coating there are hundreds of possible component and process selections. This section deals with some of the considerations surrounding these solutions.

The emphasis is placed on powder fusion rather than powder application.

To gain perspective the objective of the total system's design must be considered. First the coating requirements must be established.

These include:

- (1) Number of colours and coating types
- (2) Whether decorative or protective
- (3) Adhesion and corrosion control characteristics
- (4) Selection of the specific powder materials to be used.

There can be various overlaps between many of these parameters which will affect the resulting system.

The physical configuration of the parts plays an important role in the proper selection of the system's components.

The cross sectional thickness of the parts and their area affects cure time, cooling. After establishing what the system is to accomplish, we can look at the equipment variables and the advantages and the disadvantages of each.

There are no absolutes in this new expanding technological area. Looking at each stage of the process individually and following the travel of the part through the system, an attempt will be made to enumerate some of the alternatives available.

28.1 Conveyor

The first consideration is logistical. Is there sufficient production to warrant a continuous system? Some of the determinates are quantity of parts processed per hour, the size of the parts, uniform or varied, whether the production is sporadic or continuous and what the next stage of manufacture will be.

Alternatives available are: manual transfer - hand process using racks and hand operations for low scale production. Another possibility is the use of a continuous conveyor.

Assuming production warrants a continuous conveyor, consideration should then be given to the method of conveying, whether it should be overhead monorail, drag chain, or some other type of conveyor. Advantages of the overhead monorail include the capability of handling a wide range of parts hung from either a single hook or a multiple fixture.

28.2 Coating and collection equipment

Since there are many aspects of this area well covered in previous sections, I only need to indicate the methods:

- (1) Fluidized bed
- (2) Manual electrostatic spray
- (3) Automatic electrostatic spray.

Along with the electrostatic spray systems, comes the requirements for the collection of the overspray. There are two primary methods for accomplishing this:

- (1) A cyclone and bag filter
- (2) A bag filter alone

Advantages of a cyclone and bag filter is that a cyclone may be more easily cleaned than a bag filter for use of separate types of powder or colours of powder.

The cyclone and bag filter has a disadvantage of particle size separation, which may mean that use of the powder creates production uniformity problems. The bag filter alone results in far less separation, but is usually used only with one colour system.

28.3 Type of Heating

TABLE 4

CHARACTERISTICS	FORCED CONVECTION	GRAVITY CONVECTION	INFRARED
Versatility	Most versatile - can work effectively with variety of sizes and shapes	Limited to uses where product temperature uniformity is not critical	Most effective on large flat surfaces. Limited effect on complex parts.
Heating uniformity	Can be closely controlled		Can be uniform where part geometry is fixed with respect to infrared generator
Economy	Dependent on parts processed.	No generalisations are possible.	
Space requirements			High output I-R generators hold length to minimum if part uniformity allows

Cure temperature and dwell time are again the function of the type of coating, part, shape and thickness. Tests are necessary to establish the best combinations for specific parts. (App. 12)

One additional parameter which must be closely considered is the possibility of the powder blowing from the parts when a forced convection oven is used. Consideration must also be given to the method of sealing the heat in the oven. Care in design should be exercised in this situation so high velocity air is not directed at the parts which tend to disturb the powder surface.

Another point to consider is the possibility of using multiple zones with multiple medium, such as a combination of an infrared first zone for rapid heat-up, with a convection second zone to accomplish the uniform fusion of the material, without the use of high velocity airflow in the entry zone followed by a convection holding zone.

Arrangement of ductwork in a convection oven is very important so high velocity is not directly discharged on the product.

Temperature in the fusion oven depends on the part configuration and coating used.

In conclusion, the variables in any powder system are so extensive that individual analysis is required to optimise economics and performance of the installation.

28.4 Powder Usage and Recovery

In the majority of cases, to obtain maximum production output with the maximum utilisation of powder, three things are necessary:

- (1) Good fixture design - properly present the object for coating so that the spray cloud "sees" maximum part area with minimum gun movement.
- (2) Good grounding of object
- (3) An effective powder recovery system.

Consideration should be given to a second electrostatic spraying method, namely the hot spray technique with the desire to achieve melt of the dry powder at the spray station.

By pre-heating the object before applying the dry powder, several advantages can be noted:

- (1) Any moisture that is present on the object will be vaporised in the pre-heat section. This moisture can be the result of the cleaning method or moisture condensation from the atmosphere.
- (2) Airborne particles such as lint, dust and dirt that cause coating imperfections will be minimised.
- (3) The coating adhesion will be better than with cold application because of better "wet out" on the part surface.
- (4) A more uniformly smooth coated surface will be obtained with cratering (small surface bare spots - pinholes) virtually eliminated.
- (5) Part grounding is more easily accomplished.

Disadvantages are:

- (1) Oversprayed finish - rough pebbled finish which results when additional dry powder is applied to the hot surface of an already fused and set coating.

29. STORAGE STABILITY CONSIDERATIONS

Introduction - Powder coatings have storage limitations just as any other form of industrial finishing material and do demonstrate certain changes in properties on prolonged storage.

A working knowledge of the storage stability characteristics of powder coatings is, therefore, of major importance to every segment of the powder coatings industry.

An attempt will be made to provide an introduction to powder stability by:

- (a) Defining essential terms^{7,9}
- (b) Discussing factors influencing powder stability¹¹
- (c) Recounting some end-users' experiences.

Storage stability can be defined as the ability of the coating material to remain in a fully useable state and produce an acceptable finish after storage over a defined period of time. In other words a stable powder coating is one which demonstrates the same application and fused film performance characteristics after storage as when it was first manufactured.

When discussing the storage stability of powder coatings the subject should be separated into two distinct areas namely that of PHYSICAL STABILITY and CHEMICAL STABILITY.

Physical stability relates to both thermosetting and thermoplastic powders. Chemical stability pertains to thermosetting powders which unlike thermoplastic powders exhibit chemical reactivity on baking. In order to explain these two areas fully, it is best to review the properties that a powder coating has to fulfill its function as a surface coating material. This can be accomplished by referring to the graph in Figure 7. On this graph the solid line represents the viscosity profile of a thermosetting powder coating from application, through melt and flow to a fully cured surface coating.

29. STORAGE STABILITY CONSIDERATIONS

Introduction - Powder coatings have storage limitations just as any other form of industrial finishing material and do demonstrate certain changes in properties on prolonged storage.

A working knowledge of the storage stability characteristics of powder coatings is, therefore, of major importance to every segment of the powder coatings industry.

An attempt will be made to provide an introduction to powder stability by:

- (a) Defining essential terms
- (b) Discussing factors influencing powder stability
- (c) Recounting some end-users' experiences.

Storage stability can be defined as the ability of the coating material to remain in a fully useable state and produce an acceptable finish after storage over a defined period of time. In other words a stable powder coating is one which demonstrates the same application and fused film performance characteristics after storage as when it was first manufactured.

When discussing the storage stability of powder coatings the subject should be separated into two distinct areas namely that of PHYSICAL STABILITY and CHEMICAL STABILITY.

Physical stability relates to both thermosetting and thermoplastic powders. Chemical stability pertains to thermosetting powders which unlike thermoplastic powders exhibit chemical reactivity on baking. In order to explain these two areas fully, it is best to review the properties that a powder coating has to fulfill its function as a surface coating material. This can be accomplished by referring to the graph in Figure 7. On this graph the solid line represents the viscosity profile of a thermosetting powder coating from application, through melt and flow to a fully cured surface coating.

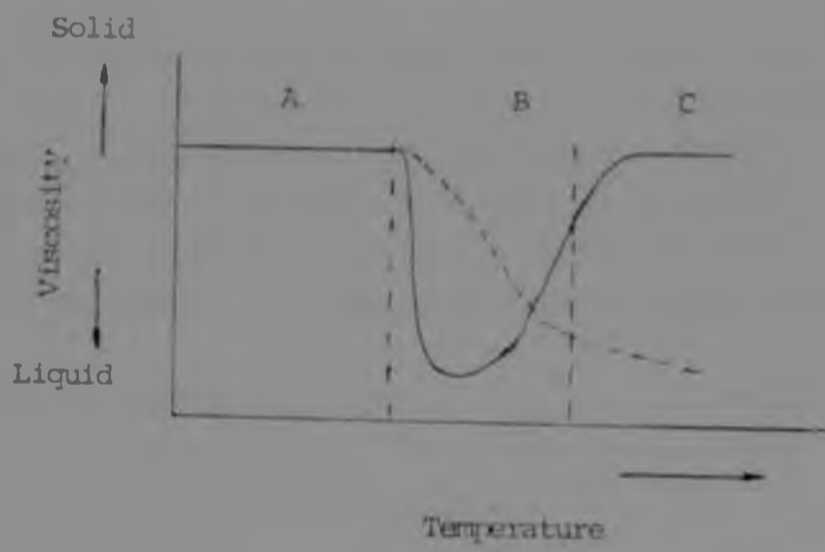

FIGURE 7

The dotted line represents the viscosity profile of a thermoplastic powder coating.

On this graph, Section A represents the physical state of the free flowing solid particles of powder during application at the gun head. Section B depicts the powder melting and flowing on the substrate during the baking operation.

Section C, the melted thermosetting powder film is crosslinking and gaining in viscosity until the non-tacky fully cured film is obtained. The thermoplastic coating (dotted line) does not show a viscosity increase in this section as a thermoplastic coating does not crosslink and go solid at temperature, but only reverts to a solid as the temperature is returned to ambient. If a powder coating is to be physically stable, it must remain as a non-tacky solid as shown by the horizontal line in Section A of the graph.

The minimum temperature at which the powder shows no softening must be above the maximum temperature that the powder will experience in storage at the end-user's facility.

Slight softening of the powder during storage causes agglomeration of the particles which will naturally alter the physical flow of the powder and the electrostatic application properties. Physical stability can, therefore, be defined as the ability of the powder to retain the same powder properties on storage and is equally important to both thermosetting and thermoplastic systems alike.

Chemical storage stability pertains only to thermosetting systems and is concerned with the ability of the powder coating to exhibit the same film properties after storage.

Referring to Figure 7 sections B and C show the powder melting to a low viscosity and then increasing in viscosity. At this low point the powder particles have melted to their fullest extent to provide a smooth continuous film which on further heating crosslinks to a solid.

This process as well as being temperature dependent is also time dependent. The time at melt has a dramatic effect on the smoothness of the film produced. The time taken for the powder to melt to a liquid and cross-link back to a solid is known as the gellation time of the powder. Thus, it can be seen that a thermosetting powder coating has a distinct viscosity profile which is dependent on its chemical composition. Any change in this chemical composition will change the viscosity profile and consequently change the final film appearance of the powder coating.

Thus chemical stability can be defined as the ability of the powder coating to maintain its chemical composition on storage in such a way as to maintain its final film properties.

An example of poor chemical stability would be a reduction of the gellation time on storage by chemical pre-reaction of the resin and crosslinker used in the powder. This pre-reaction will cause an increase in molecular weight of the system resulting in a lessening of the viscosity drop on melt, and a reduction in the time at melt. The net result in respect to the film appearance being that of reduced flow and increased orange peel.

Plasticization by definition lowers the softening point of the resin and must, therefore, be carefully controlled in respect to physical stability.

Finally, the particle size distribution to which a powder coating is manufactured must be controlled as finer particles tend to pack more densely than coarser particles. The increased surface contact and a higher bulk density will ultimately result in a greater chance of agglomeration.

Similarly, chemical stability of a powder is also affected by several environmental conditions such as temperature and time. The storage temperature is of major concern as generally the higher the storage temperature the more quickly the powder will deteriorate chemically. This chemical deterioration is not only temperature, but time dependent, so that inventory time is of equal concern. The chemical stability of a powder coating system can be significantly altered by intelligent formulation.

Each combination of base resin and curing agent exhibits a characteristic reaction rate, with some combinations being inherently more stable than others.

Most thermosetting powder coatings today are formulated to have good physical stability, but where special film properties are required, it is sometimes necessary to formulate products demonstrating limited shelf stability. With a correct understanding of powder storage stability, compromises on physical and chemical stability can be made to enable the formulator to meet specific requirements not possible with "standard" materials.

Perhaps the most simple and useful of accelerated testing is to place a small sample of powder in a sealed container at the desired exposure temperature. Considering the temperatures to which a powder could be exposed during transit and storage it is felt that accelerated testing at 50°C is a realistic procedure. If bulk handling of powder is under consideration, weights should be added to simulate the pressure resulting at the bottom of the powder container.

29.1 Factors Influencing Storage

The factors influencing both physical and chemical stability will be discussed with supporting test data.

Physical stability of a formulated powder coating is affected by the following environmental condition:

- (a) Temperature
- (b) Humidity
- (c) Compaction by vibration or pressure.

The storage of powders at temperatures above 25-30°C can cause softening of the powder particles with subsequent agglomeration. This agglomeration can cause spitting from the electrostatic spray guns with consequential specking in the fused powder film.

High humidity has a similar effect on powder handling and application.

Finally the degree of compaction due to vibration can also significantly alter the handling properties. Physical stability is also dependent on the initial formulation and the parameters to be considered in formulation include the following:

- (a) Resin T_g (hardness)
- (b) Pigmentation level
- (c) Plasticizer and additive level
- (d) Particle size range.

Resin T_g is related to the onset of polymer softening and, therefore, must be in excess of the temperatures encountered during product use and storage. Generally, the pigmentation of a resin system improves physical stability, but the magnitude of this improvement is not as significant as those improvements achieved by resin design.

During the evaluation the following tests should be performed at specific intervals on the test samples:

Physical stability

- (a) Caking or blocking*
- (b) Application properties (gun properties and finished film appearance)
- (c) Changes in particle size distribution.*

Chemical stability

- (a) Gel time - gloss
film continuity
- (b) Coating performance - orange peel
physical tests.

To demonstrate the effect of resin Tg on physical storage, a series of thermosetting resin representing three generic types were formulated (by APCI) into clear powder coatings. These powders were evaluated for physical stability as a function of storage temperature. For the three powders presented in Table 5, as the Tg increased a definite improvement in physical storage stability was noted.

Table 5

EFFECT OF RESIN Tg ON PHYSICAL STABILITY

	Major resin Tg (°C)	Storage temperature		
		25°C	40°C	50°C
Resin A	48	Pass (P)	Fail (F)	F
" B	55	P	P	F
" C	63	P	P	P

The experimental result presented in Table 6 will serve to illustrate several points related to chemical stability. The chemical stability properties of a "standard" epoxy powder coating are presented as a function of storage time at constant temperatures. The condition of

the samples during the storage was monitored by checking gel time and gloss of the final film. Similar trends in film deterioration can be noted by evaluating orange peel level. Specific points to note are the excellent shelf stability if temperature is maintained less than 25°C and the failure point decreases as storage temperature is decreased.

Table 6

Ambient storage			40°C storage			50°C storage		
Days	180°C Gel	60°C Gloss	Days	180°C Gel	60°C Gloss	Days	180°C Gel	60°C Gloss
0	80	100	0	80	100	0	80	100
-	-	-	-	-	-	1	65	99
-	-	-	8	60	100	8	50	93
-	-	-	-	-	-	11	45	50
-	-	-	15	55	98	15	40	25
30	80	100	30	50	98	-	-	-
90	70	99	-	-	-	-	-	-
180	65	99	-	-	-	-	-	-

29.2 End Users Experiences

It has been proven that storage stability properties of powder coatings need not cause problems at end-users' facility provided that a few simple precautions are taken.

A basic recommendation would be that there be effective communication between the powder supplier, the equipment manufacturer, and the end-user. This open communication will result in a better understanding of the complete system requirements, thus avoiding potential problem areas including those related to powder stability.

Some specific recommendations are:

- (a) Control temperature in the powder coating storage area at the end-user's plant.
- (b) Efficiently rotate the stored powder to minimise inventory time, so that powder is never stored beyond the manufacturer's recommendation.
- (c) Minimise holding of the powder coating material on shop floor if temperature and humidity of application areas are not controlled.
- (d) Precondition powder prior to spray application by:
 - (i) Providing preconditioning fluidisation as is available on automatic systems, or
 - (ii) Adding virgin powder through reclaim system.
- (e) Maximise powder transfer efficiently in the booth to avoid the problems associated with the recycling of large quantities of powder.

In conclusion, powder coatings can demonstrate excellent shelf stability and can provide essentially trouble-free finishing operations when used intelligently.

30. ELECTROSTATIC CONSIDERATIONS

Electrostatic (E/S) considerations play a major role in the performance of E/S powder spraying systems. As powder spraying requirements become more sophisticated, so too must our knowledge of all factors that influence coating behaviour.

Much of the physics from the E/S precipitation field is pertinent to E/S powder spraying, but care must be exercised in its adaptation. For example, most of the organic powders which perform well in E/S powder coating applications are not easily susceptible to E/S precipitation unless special treatment is provided to increase their electrical conductivity.

Unusual problems in E/S powder spraying will require a return to basics in order to reach a solution. This section has attempted to point out major factors that offset the E/S charging of powder particles and their deposition. In some instances a knowledge of these factors can provide simple solutions to coating problems. In other instances additional research is required.

30.1. Abstract

Upon the introduction of the powder coating process there were no test methods and specifications geared specifically for this new coating.

Because the materials, application processes and end properties and the coating are entirely different from coatings formerly available, it is necessary to design, evaluate and validate many new test methods to assure the quality of these coatings.

Special tests for determining particle size, size distribution shape and handling characteristics are necessary due to the very fine powder used.

The influence of these materials offsets the coating characteristics and quality of the coating and should be evaluated.

A list has been drawn up, of standard methods of test which can be used with minor deviations in sampling procedure, specimens or procedure to obtain useful results.

The methods include those for the powder materials and the final coating. These methods are described briefly with the special procedures being pointed out.

Specific tests have been developed for properties which were not previously encountered in coatings such as edge coverage, cut-through resistance, flow ability and gel time.

A description of the test specimen, method of preparation and procedure for these tests is given. Prepared future test methods and specifications are reported.

30.2. Properties of Powders

Powder coatings have been used for the past 15 or more years to coat a variety of metal parts which require special protection and could not be coated by other methods.

These coatings provide film by a different chemistry than solvent type coatings. Since the powder coating materials are of a new vintage it is essential to establish many new methods for evaluation and control of the quality of the coating materials and the coatings. Some of the properties of powders that are important in order to control the quality of the material and the uniformity of application are :-

Particle size and shape
distribution of particle sizes
specific gravity
apparent density and bulk factor

cure temperature
melt viscosity and flow rate
temperature of application and gel time
percent edge coverage
moisture content

Some of the physical properties that are important for the final coating are :

hardness and cut through resistance
impact resistance
adhesion
mar resistance
flexibility
thermal evaluation

The materials used in coating powders are compounded to provide a 100% non volatile resin mixed with fillers, flow control agents and usually (not in M.B. application) colourants.

These materials are solid at room temperature and are usually blended while hot, then cooled, pulverized and screened to obtain the powder necessary for coating.

The size and shape of the individual particles determine the manner in which the powder can be handled and applied. For example, the angle of repose and angle of internal friction (Fig 8)^{10,11} are dependent on the shape of the particles and determines how well the powder will flow from a hopper or a bin.

The powder materials are fed by vibrators, air pumps and screw devices. The performance of the powder during handling by these methods is controlled by the particle size and shape and its blocking or compacting characteristics. The blocking characteristics are quite important for storage of powdered materials.

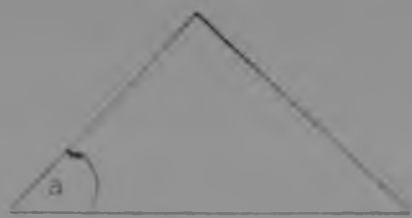

Angle of repose (a)



Angle of internal friction (b)

Figure 8

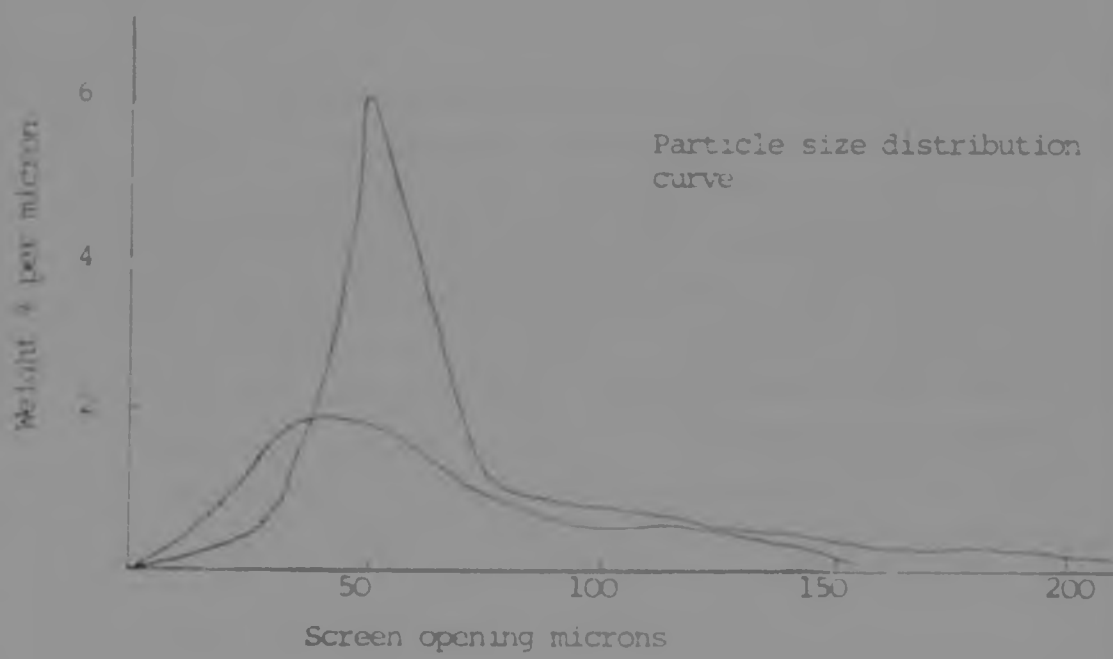

Figure 9

If the materials tend to stick together or fuse, they form into a large lump which must be broken up before it can be handled and used as a coating powder. The shape and size of powder particles influences their tendency to agglomerate. This in turn determines the minimum film thickness that can be applied with that particular powder.

The coating powders are supplied by electrostatic spray or fluid bed. The size and shape of the particles as well as its polar structure determines how well the material holds a charge during the coating process by these methods.

It is desirable that the particles be very small in the order of 10 - 100 microns, to apply a thin uniform coating by electrostatic methods.

The finer the powder the thinner the coating that can be applied but if the very fine particles tend to stick together they give a thicker coating.

Some of these coating characteristics are new and it is necessary that test methods exist to determine and control the particle size and shape that is obtained during the manufacture of the powder to obtain the best coating characteristics. The ability of the particles to remain as discrete particles without agglomerating during handling and storage must also be controlled. The test methods that are presently being used to determine particle size are conventional screening through a series of decreasing size opening and determining the percentage of powder passed or retained on each size. (AFCI Coulter meter reading)

The practical limit of this method is about 400 mesh (37 microns)⁸²⁰ and larger. Since the fine powders tend to agglomerate due to electrostatic force it is sometimes necessary to use carbon black to aid the particles in going through very small opening screens.

If the materials tend to stick together or fuse, they form into a large lump which must be broken up before it can be handled and used as a coating powder. The shape and size of powder particles influences their tendency to agglomerate. This in turn determines the minimum film thickness that can be applied with that particular powder.

The coating powders are supplied by electrostatic spray or fluid bed. The size and shape of the particles as well as its polar structure determines how well the material holds a charge during the coating process by these methods.

It is desirable that the particles be very small in the order of 10 - 100 microns, to apply a thin uniform coating by electrostatic methods.

The finer the powder the thinner the coating that can be applied but if the very fine particles tend to stick together they give a thicker coating.

Some of these coating characteristics are new and it is necessary that test methods exist to determine and control the particle size and shape that is obtained during the manufacture of the powder to obtain the best coating characteristics. The ability of the particles to remain as discrete particles without agglomerating during handling and storage must also be controlled. The test methods that are presently being used to determine particle size are conventional screening through a series of decreasing size opening and determining the percentage of powder passed or retained on each size. (AECI Culter meter reading)

The practical limit of this method is about 400 mesh (37 microns) and larger. Since the very fine powders tend to agglomerate due to electrostatic forces it is sometimes necessary to use carbon black to aid the particles in going through very small opening screens.

Vibratory and vacuum methods are used to obtain more consistent results and to eliminate operator influence in determining particle sizes. But these methods are also limited to about 400 mesh and larger sizes for reliable results. It has been demonstrated that powders perform better in coating when the weight percent of various particle sizes has a bell shaped distribution curve (Figure 9). This means that most of the particles have a narrow range of sizes and that there are relatively few longer and smaller sizes. The sharper the peak, the more uniform size, the better the handling characteristics. Powders having most of their particles in the 50 micron size provide very good coatings.

Determination of very fine particle sizes can be done by sedimentation tests from a suspension of the powder or by microscopic examination of the material. The former method is very slow and care must be exercised in the selection of the liquid to prevent reaction with the powder or influences on the results due to polar attraction. The latter method is limited due to the very small sample size that is allowed in the field of a microscope. The microscope is also used to determine the shape of the particles.

A magnified view of an epoxy resin powder has shown the fine particles surrounding the longer areas and the very fine ones agglomerating. * The same powder was screened and the fraction retained on an 80 mesh screen showed the particle shape to be generally five sided. This material has shown to have good handling characteristics. The control of the shape must come from the method of grinding and classification of the sizes. The flow or levelling ability of a powder has been determined by methods such as an inclined plane, flow of the material through various sized orifices, determination of melt viscosity and change in viscosity by torque measurements during cure, and use of a differential scanning calorimeter (DSC). No standard method of determining flow has been adopted to date.

The inclined plane flow test (figure 10) is being used successfully for certain materials but does not seem to give good results over a wide range of flows. On this test uniform size pellets of powder are placed on preheated glass slides which are tilted after a specified time to cause the melted pellets to flow. The length of flow is measured after the material cures. The length of flow through an orifice is determined by placing uniform powder pellets over various size holes in a preheated plate. The length of flow through the holes is measured after cure. This method is highly dependent upon specific gravity and gel characteristics of the powder. It cannot be used for a wide range of flow volumes because a viscous material will not flow and thin film materials will separate and drop away. The determination of flow by melt viscosity and torque measuring methods is elaborate and expensive and the results are not directly related to actual performance as a coating. The DSC equipment is very elaborate and requires skilled operators to obtain repeatable results. This device appears to provide much information such as melt temperature, duration of melt, gel time and temperature and exothermic energy, but there is some question of how to relate this data to coating characteristics. In an attempt to provide a simplified method of determination of flow which would be reproducible and relatively inexpensive a spiral flow mould was developed (Figure 11). It consists of a grooved lower mould half which is calibrated in millimetres from the centre. The upper mould half has a 25mm diameter opening for introduction for the material and weighted plunger is placed on the material immediately after it is introduced into the mould. The mould is preheated to a specified temperature and when the weighted plunger is placed on the powder the material flows through the spiral until it gels. The amount of flow is influenced by gel time viscosity thermal conductivity as related to specific gravity, cure time and temperature.

The length of flow of this mould can be reproduced for a given powder and the length of flow can be related to the gel time and levelling characteristics of the powder.

The inclined plane flow test (figure 10) is being used successfully for certain materials but does not seem to give good results over a wide range of flows. On this test uniform size pellets of powder are placed on preheated glass slides which are tilted after a specified time to cause the melted pellets to flow. The length of flow is measured after the material cures. The length of flow through an orifice is determined by placing uniform powder pellets over various size holes in a preheated plate. The length of flow through the holes is measured after cure. This method is highly dependent upon specific gravity and gel characteristics of the powder. It cannot be used for a wide range of flow volumes because a viscous material will not flow and thin film materials will separate and drop away. The determination of flow by melt viscosity and torque measuring methods is elaborate and expensive and the results are not directly related to actual performance as a coating. The DSC equipment is very elaborate and requires skilled operators to obtain repeatable results. This device appears to provide much information such as melt temperature, duration of melt, gel time and temperature and exothermic energy, but there is some question of how to relate this data to coating characteristics. In an attempt to provide a simplified method of determination of flow which would be reproducible and relatively inexpensive a spiral flow mould was developed (Figure 11). It consists of a grooved lower mould half which is calibrated in millimetres from the centre. The upper mould half has a 25mm diameter opening for introduction for the material and weighted plunger is placed on the material immediately after it is introduced into the mould. The mould is preheated to a specified temperature and when the weighted plunger is placed on the powder the material flows through the spiral until it gels. The amount of flow is influenced by gel time viscosity thermal conductivity as related to specific gravity, cure time and temperature.

The length of flow of this mould can be reproduced for a given powder and the length of flow can be related to the gel time and levelling characteristics of the powder.

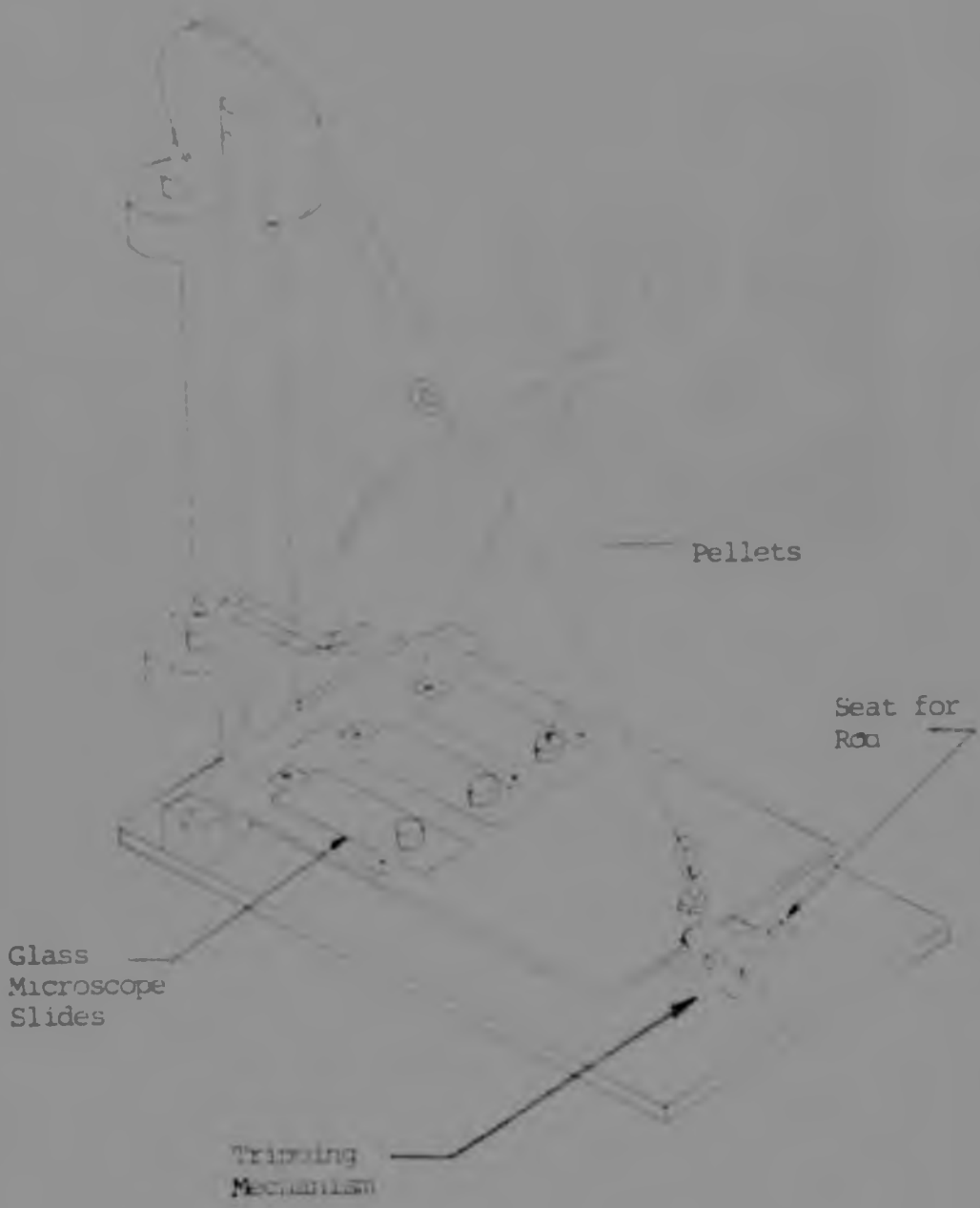

Figure 10



SPIRAL FLOW MOLD

FIGURE 11

There is no known direct relationship between the flow length and the smoothness of coating, but, since many factors that influence the coating also influence the flow in the mould a relationship between the two could be established for a given material. Many metal parts are punched or perforated leaving a very sharp edge. Thus, the ability to cover the edges was probably the foremost reason that powder coatings were initially used for electrical insulation and are important for other applications. Edge coverage is a property which was not available in liquid coatings because liquids tend to flow away from sharp edges. It is possible to formulate powder coatings which do not flow away from very sharp edges. This is accomplished by the incorporation of fillers and flow control agents into the material and controlling the melt viscosity and gel time of the coating powder, but it is not of particular interest for our application.* It should be mentioned though that the powder industry has had a general agreement on one method of test for determination of percent edge coverage.

This method consists of coating a preheated 12mm square steel bar having sharp edges (figure 12). Measurements are taken on the bar before and after coating across the flats and across the diagonal at the same distance from the end of the bar. The edge coverage is obtained by dividing the thickness of the coating on the sharp edges by the thickness on the flat surfaces.*

The specifications for powders should include the maximum permissible amount of moisture present since all very finely divided particles have an affinity for moisture. The presence of moisture in a powder may cause it to fuse together or become lumpy during storage. Moisture also influences the cure rate in some powders such as epoxy resins. The amount of moisture pick up after manufacture must be considered also. Powders can pick up moisture during storage.

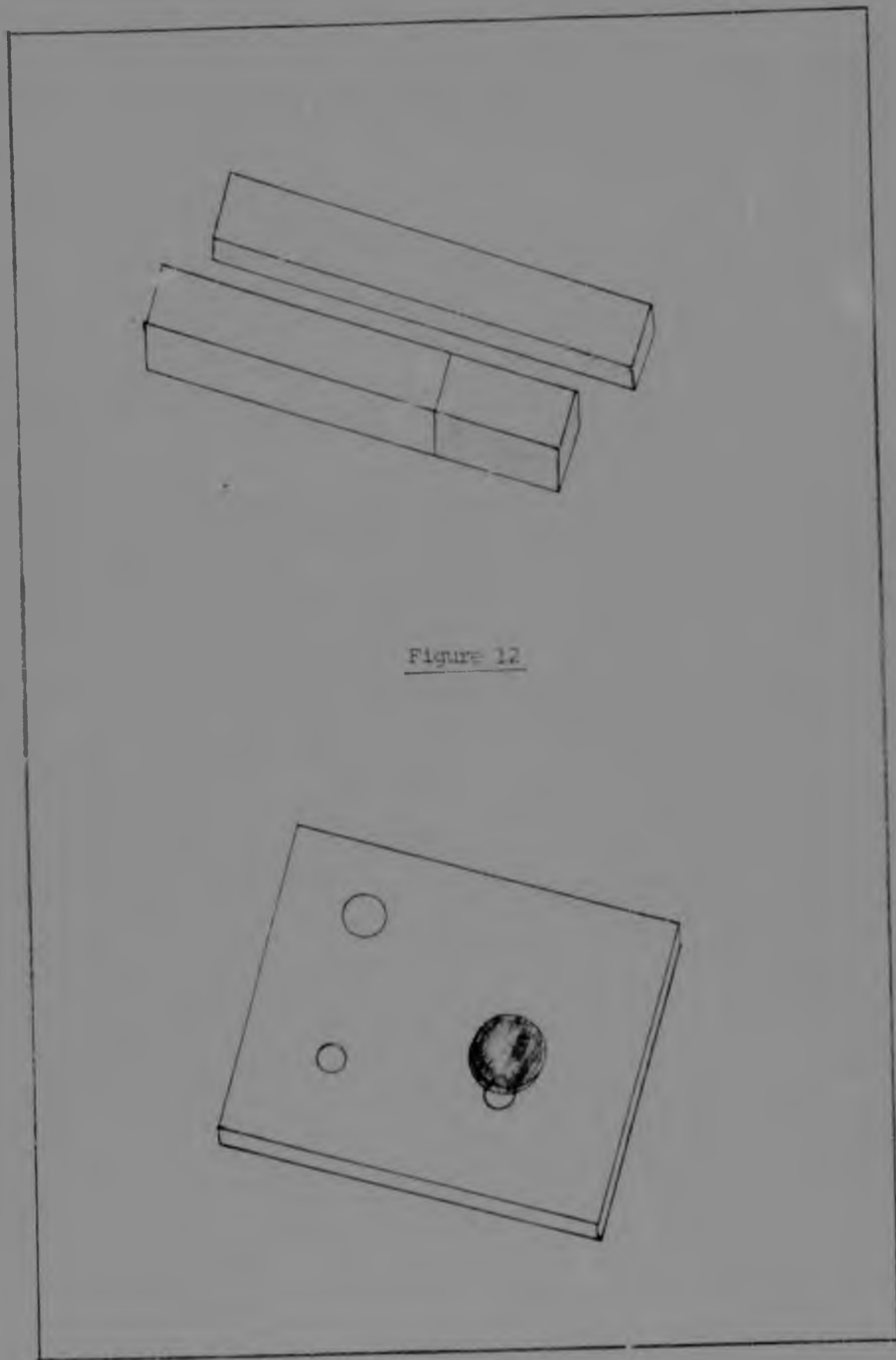

Figure 12

33. STATIC ELECTRICITY

33.1. Abstract

This section has been prepared to provide a basic understanding of static electricity, some of the problems it causes industry and to discuss the Spengler Ionisor.

33.2. The Product Requirement

Static charges are prevalent throughout most plants or laboratories where synthetic or raw materials produce friction during production or where the material is changed from cold to hot or hot to cold, or is under pressure. Most materials are generally subject to very high electrostatic charges and their surfaces are soiled by dirt and impurities attracted by electrostatic forces.

It is important to treat the material by some form of ionisation coupled with some form of surface cleaning. The inability to control static can be very expensive. Although static has always been a problem, the magnitude of this problem has increased by giant steps with the advent of more and more industrial processing of plastics, synthetics and volatile materials.

Costs have been increased through the expense of fire and explosion repairs and the attendant loss of materials and production. In our application we had to look for a unique device which would eliminate the static from the sheets when processed in the horizontal mode. The spengler product appeared to be clearly the best choice and approach for this particular problem. The product is expensive in relation to alternate products, but provides results which can justify the expense.

The test method used to determine the percent of moisture is by drying the sample and determining the weight loss.

Chemical analysis also can be used to determine the percent of moisture present. The amounts of moisture present in powder can vary between 0,1 and 3%.⁷⁵ Some powders can tolerate more moisture than others but amounts over 1% usually show up as bubbles in the coating when it is heat fused, particularly if the material cures very fast, when trapping bubbles are formed by moisture.

The hardness of thick powder coatings can be determined by measuring the indentation of a weighted ball. This method is not satisfactory for thin coatings as is the case here, but conventional hardness methods can be used for most thin coatings.

The resistance to cut through of powder coatings at elevated temperature is an important method for evaluation of quality. At present no standard test procedure has been adopted but the methods being used by various industries are being evaluated to determine the one best suited for our purpose.

Some of these methods are as follows:-

A weighted chisel point against a heated panel, a wire or knife edge against a heated bar and deformation of the film under varying loads. The latter has been used repeatedly in this project with good indications about the quality of the coating which were confirmed by verification on different devices such as a seamer. An impact test is used to determine the toughness or brittleness of powder coatings. This test consists of dropping a weighted ball onto a coated panel against a solid anvil from various heights until the coating fractures. It is necessary to develop more severe tests to provide a means of evaluating all powder coatings.



DEFORMATION EDGE

The adhesion and mar resistance of coatings are evaluated with scrape adhesion testers. The test consists of drawing a weighted anvil along the surface with increasing loads until the coating is penetrated.

Other test methods that would be useful for evaluating powder coatings are : hiding powder, coating porosity, accelerated aging of powder, acceptance of electrical charge and safety characteristics. At present the powder coating industry is going through a period of rapid changes and improvements in the materials available and in the equipment available for applying these materials. It is just as important that the methods of evaluation and determination of the quality of these materials and coating keep pace with the rest of the industry.

31. ELEMENTS OF E/S POWDER COATING SYSTEM

The three major elements of an electrostatic (E/S) powder spraying system can be listed as :

- a) powder delivery apparatus
- b) powder gun
- c) object to be coated

In an ideal system the coating concept is simple. The powder delivery apparatus delivers powder to the powder gun at a constant known flow rate with particles well dispensed.

Uniform charging of the particles at the gun by unipolar ions causes them to remain dispersed as they are guided to the substrate by the electric field. At the substrate the charged particles form a deposited layer of uniform thickness, which adheres to the substrate by E/S attraction. The so called 'self limiting' build up characteristic tends to make the deposited layer quite uniform, to provide good edge coating and to enhance the wrap around of powder on the coated object.

In actual practice, coating performance may be inadequate for E/S or other reasons. Definition of problems is made easier if the performance of each of the major elements of the spraying system can be evaluated.

In the following discussion the E/S behaviour of particles is examined as they proceed through four major zones of interest. Powder delivery apparatus, charging zone, spray zone and deposit layer. The influence of the various system parameters on E/S performance can be assessed and possible sources of coating difficulties can be identified.

31.i. Powder Delivery Apparatus

The delivery of powder to a powder gun, under well dispersed conditions and at the desired flow rate, may involve problems other than electrostatics. Present concern, however, is about the triboelectric charging of the powder particles, which occurs in the powder delivery apparatus.

NOMENCLATURE

a	=	radius of particle
d	=	specific gravity of powder dimensionless
e	=	electrostatic charge, coulomb
j	=	current density in deposited layer, amp/m ²
m	=	mass of particle, Kg
q	=	charge on particle, coulomb
t	=	time, seconds
u	=	mobility of ions, m ² /volt - sec
w	=	migration velocity, m/sec
A	=	surface area of particle m ²
C	=	capacitance, (farad)
Ed	=	electric field intensity in deposited powder, layer volts/m
Eo	=	electric field intensity which is effective in charging a particle, volts/m
Ep	=	electric field intensity at point (p) in spray zone volts/m
F	=	electrostatic force on particle, Newton
N ₀	=	unipolar ion concentration in particle charging region ions/m ³
V	=	voltage, volts
w	=	Energy in a single spark, joule
e ₁	=	dielectric constant of powder particle, dimensionless
e _o	=	constant 8,85 x 10 ⁻¹² farad/m
r	=	bulk resistivity of deposited powder, time constant of particle charging, sec
n	=	viscosity of air, 1,8 x 10 ⁻⁵ Kg/m-sec
Microcoulomb μC	=	unit of charge = 10 ⁻⁶ Coulomb
KV	=	unit of voltage = 1000 volts
pf	=	unit of capacitance = 10 ⁻¹² farad

The present knowledge of triboelectric charging is not adequate to let one predict how much of this type of charging will take place as the particles rub along various surfaces in the fluidizing and transport sections of the apparatus. The reason for the importance of tribocharging as a possible problem is that its magnitude can be as large or larger than the magnitude of the corona charge that is applied by the powder gun. Polarity of tribocharging is sometimes positive and sometimes negative depending upon the specific powder and delivery apparatus. Coating difficulties can occur if the corona charging system cannot properly re-charge particles that carry a large tribocharge of opposite polarity.

In instances where the magnitude of the tribocharge is large and of opposite polarity to the gun potential, it is tempting to spray the powder with no high voltage on the powder gun.

This generally results in poor adhesion of the powder to the substrate perhaps due to non uniform powder charging. Since particle charge level is an important factor in E/S powder spraying it is useful to be able to determine its value. With no voltage on the powder gun, the magnitude and polarity of the net tribocharge can be measured by the faraday pail technique, wherein the charged particles are collected in a conductive insulated container. If gun potential is not zero, it is necessary to collect the free ions by a suitable electrode such as a grounded open mesh screen, so that these ions do not contribute charge to the Faraday pail. By measuring the voltage (V) of the Faraday container and the mass of the collected particles, the charge per unit mass (q/m) can be calculated as follows:-

$$\frac{q}{M} = \frac{CV}{M}$$

It is convenient to convert (q/m) to charge per unit area (q/A) in order to compare actual charge levels to the 'theoretical saturation value!

This is done by assuming spherical particles and an average particle radius (a) and using the relationship

$$\frac{q}{A} = \frac{q}{M} \times \frac{10^3 a.r.}{3}$$

values of 3 - 9 Microcoulomb/m² of tribocharge were measured on sprayed powders used. Corona charge levels tend to be in the same range. (Ref. 10 - 27 used throughout this chapter).

More sophisticated techniques can be used to measure charge distribution in powders and to detect the presence of both polarities of charge. Turner, for example, described a method which employs a transverse electric field to deflect charged particles and a multiple Faraday pail unit to classify particles according to charge level.

31.2. Powder Gun

As the powder particles move from the powder delivery system through the gun, they are charged by ions that flow from the corona electrodes to the object to be coated.

Some of the ions impinge on powder particles and are carried by these particles to the grounded object. The remaining ions flow as 'free ions' to the grounded object. This method of particle charging is known as field charging and the charge (q) on the particle can be calculated by Pauthenier's expression.

$$q = 12 \frac{e_1}{e_1 + 2} \pi e_0 a^2 E_0 \frac{t}{t + \tau}$$

The time constant (τ) of charging is given by $\tau = \frac{4e_0}{\text{No.} \cdot e \cdot \mu}$

Normally the concentration of unipolar ions (No) is sufficiently large that the charging time constant (τ) is in the order of a few milliseconds. The factor $\frac{t}{t + \tau}$ is then approximately equal to unity and the charging equation can be simplified to express the saturation charge per unit area $\frac{q_s}{A}$ on the particle as :

$$\frac{qS}{A} = 3 \frac{e_1}{e_1 + 2} e_0 E_a$$

For particles of a given dielectric constant (e_1) it is evident that the maximum attainable charge density on the particle is proportional to the magnitude of the externally applied field (E_0) at the point where charging occurs. This point differs for different particles in the spray. The magnitude of the electric field (E_0) is maximum near the corona electrode and decreases rapidly and non linearly as distance increases toward the grounded object. Because the ions must follow the electric field lines from the gun to the substrate, charging difficulties arise when some of the particles are shielded by other particles in the high field region.

When this occurs, the particles receive less charge because of the lower value of (E_0) in charging regions remote from the corona electrode. This lower charging can be expected to occur when powder flow rate is increased, or when average particle size is decreased at a given flow rate. Powder agglomerates charge poorly owing to their low surface area to mass ratio. Likewise, small particles can be charged to a higher (q/m) ratio than larger particles.

This can be an advantage in situations where aerodynamic forces assist E/S forces in deposition -

A negative polarity on the powder gun is usually superior because, as in most corona charging applications, this polarity on the active electrode offers better stability of ion flow and less arcing tendency than does positive polarity.

31.3. Movement of Charged Particles in Electric Field

As the charged particles leave the powder gun and proceed toward the grounded substrate, the two primary forces acting on them are electrostatic and viscous forces.

Gravitational and inertial forces can be presumed to be small. The E/S force (F) can be expressed as $F = q E_p$

This force causes the charged particles to move along the electric field lines which diverge from the corona electrode to the substrate. Where electric field lines terminate on corners, edges and the rear surface of a grounded object, powder will be deposited in these locations. On locations where E/S forces must oppose viscous forces to cause deposition it is ideal to analyse the E/S problem by referring to the expression for the steady state migration velocity for field dependent charging in E/S precipitation.

$$w = \frac{2e_0 E_0 E_{pa}}{n}$$

A higher migration velocity for particles results in more powder on the coated object and less overspray. In this situation a larger particle diameter can be advantageous. (Ref. to bibliography).

On certain occasions the particle - guiding forces produced by the electric field become a disadvantage, by creating what is known as the, 'Faraday Cage' effect. This effect produces unusual difficulties in getting powder to deposit in deep, narrow, concave surfaces and crevices on objects, because the electric field lines do not project into the deep recesses and powder is not guided into these regions. Viscous forces can sometimes be used to carry charged powder into Faraday cage regions, but the proper balance of forces is rather delicate.

31.4. Particle Deposition

Getting powder particles to the desired location on the substrate is only part of the job. These particles must adhere to the substrate until baking can be accomplished. E/S forces of adhesion are derived from two sources: Charge carried by the particles to the substrate, and free ion flow which further charges the deposited particles. Most organic coating powders have a high electrical resistivity ($r > 10^{12}$ ohm - m) and show a self limiting build up during E/S spraying. This is usually attributed to a redistribution of electric field lines to the substrate as particle build up raises the potential of the surface of the deposit.

The thickness of the build up is influenced by the magnitude of the free ion current as would be expected.

In view of the high resistivity of these particles, free ion currents, in passing through the deposit, develop an electric field intensity (E_d) expressed by the equation

$$E_d = rj$$

When E_d exceeds about 6×10^6 volts/m, dielectric breakdown occurs in the deposit and the resulting ionisation is called 'back corona.'

This ionisation produces ions of a polarity opposite to that of charges on the particles. These new ions neutralise the charges on approaching particles so that little additional deposition is likely to occur at sites of back corona. Back corona can assume several forms and can cause severe coating difficulties such as cratering under certain conditions.

It should be noted that powder resistivity is an important parameter mainly in the deposit layer where, for most organic powders, electric field intensity is near or at the breakdown value.

If a powder has a resistivity sufficiently high to exhibit self limiting build up during E/S spraying it is probable that the actual value of resistivity is not critical to coating performance. It is normally assumed that the object to be coated is conductive and grounded. This provides a path to ground for free ions so that the substrate will remain at ground potential and allow charges to be induced as the substrate adjacent to the powder coating. These induced charges assist in binding the charged powder to the substrate.

31.5. Adhesion

One of the purposes of E/S charging is to cause the powder particles to adhere to the coated object by E/S attraction until baking is accomplished. If one calculates or measures the time constant of charge decay for the charged layer, however it is apparent that the E/S forces can exert an influence for only a short time (in the order of a few minutes).

The long term adhesion of unbaked powder coatings is attributed to Van der Waals forces.

Much remains to be learned though, about adhesion phenomena in powder coatings.

31.6. Electrical Safety Considerations

Fire and dust explosion hazards must be guarded against during E/S spraying of organic powders. Two precautions should be taken:-

- a) good practice dictates that the concentration of powder in air be kept below the minimum explosive limit by providing sufficient air dilution. A good rule is to keep the powder concentration less than 20 Kg/l 000m³ of air (ref1). The second precaution is to limit the energy in possible sparks to a value below the minimum ignition energy for the powder dispersed in air.

This value will vary from one powder to another, but the lowest value reported to date for commonly used organic powders is 10 mJ. To obtain 10 mJ of spark energy it is necessary for a conductive ungrounded object, acting as a capacitor to become charged and to dissipate that charge in a spark.

This capacitor can be part of the spray gun or its high voltage supply, an object in the spray booth, or even the operation.

In view of the squared relationship between voltage and energy $w = \frac{1}{2} CV^2$

the capacitance of an ungrounded object need not be large at the usual values of gun voltage to store 10 mJ of energy.

33.9. Operation

Theoretically, the objects carried into the spray booth should be grounded through the hangers, so that the SR ionisors are only needed to provide contactless earthing in cases where the flow of electrons in the hanger is blocked either partially or completely. But the SR ionisor is capable of assuring the grounding of the objects regardless of the condition of a particular hanger.

This fact opens up an entirely new approach to electrostatic powder coating.

The objects are introduced to the booth deliberately insulated. The grounding effect provided by the SR ionisor can be increased or decreased at will by adjusting its distance to the object. The air between object and ionisor which is made conductive by ionisation, has an electrical resistance that varies with this distance. Changing the distance, then, slows down or speeds up the rate of removal of the electrons induced on the object by the spray gun.

This effect makes it possible to coat more evenly because ideal powder envelopment is assured. The speed of the powder cloud can be matched to this conductive effect so that just the desired type of finish is obtained. If desired, a grounding monitor can be incorporated in the control unit to provide a continuous reading of ignition energy and to shut down the entire coating installation should a certain limit (normally * 5 MJ) be exceeded. This monitoring attachment can either be installed stationary or supplied as a mobile unit. The necessary SR ionisors can be mounted on an adjustable frame. The powder supply and self monitoring are taken care of by a control unit in a dust proof enclosure.

SR ionisors are approved and certified for use in explosive gas atmospheres, thus providing a maximum of safety.

The long term adhesion of unbaked powder coatings is attributed to Van der Waals forces.

Much remains to be learned though about adhesion phenomena in powder coatings.

31.6. Electrical Safety Considerations

Fire and dust explosion hazards must be guarded against during E/S spraying of organic powders. Two precautions should be taken:-

- a) good practice dictates that the concentration of powder in air be kept below the minimum explosive limit by providing sufficient air dilution. A good rule is to keep the powder concentration less than 20 Kg/1 000m³ of air (ref1). The second precaution is to limit the energy in possible sparks to a value below the minimum ignition energy for the powder dispersed in air.

This value will vary from one powder to another, but the lowest value reported to date for commonly used organic powders is 10 mJ. To obtain 10 mJ of spark energy it is necessary for a conductive ungrounded object, acting as a capacitor to become charged and to dissipate that charge in a spark.

This capacitor can be part of the spray gun or its high voltage supply, an object in the spray booth, or even the operation.

In view of the squared relationship between voltage and energy $w = \frac{1}{2} CV^2$

the capacitance of an ungrounded object need not be large at the usual values of gun voltage to store 10 mJ of energy.

At 60 KV for example a charged capacitance of only 5,5 pf (App. 2) is hazardous. To protect against the static ignition hazard, all conductive surfaces and objects in and near the spray booth should be grounded.

Current limiting resistors should be used in the spray guns. These resistors should be located as close to the corona electrode as is feasible so as to minimise surge capacitance in the electrode circuit.

31.7. Back Ionisation

Back ionisation is effectively the electrical breakdown of the powder layer resulting from the electrical field across the layer exceeding breakdown conditions. At the onset of this discharge, a high density of positive and negative ions are created within the layer. For a negative charged system the newly created negative ions are collected by the workpiece while the positive ions move towards the gun and discharge further oncoming powder. Deposition efficiency immediately deteriorates, leading eventually to zero deposition or self limiting.

Back ionisation behaves differently for negative and positive charge powder.

For negative charging, the layer discharge is a bulk phenomenon which completely penetrates the powder layer generally leaving a pin hole. If the powder flow characteristics are not chosen carefully, this pin hole may persist after curing. Generally negative charging gives smoother finish but it is prone to pin holing.

31.8. Air vs Electrostatic Forces

The development of a laser doppler anemometer¹ system has enabled precision tracking of particle trajectories under realistic gun/workpiece arrangements. Effects of gun air and ion concentration on coating behaviour have been identified by controlling each variable independently. An airless gun eliminated the effects of gun air on powder trajectories.

For standard commercial corona charged gun systems the gun air predominates in conveying the powder to within a few centimetres from the workpiece surface. Near the workpiece, electrostatic forces take over in directing the particles and retaining them on the substrate.

As a result of their greater mass and lower mobility, the larger particles are more responsive to electrostatic forces than the fine.

For this reason, a certain degree of particle size separation occurs between the front and back face of a workpiece.

There is usually a predominance of larger particles on the back face compared to the front.

31.9. Powder Feed Rate

The effect of powder feed rate on coating efficiency has been clarified from extensive tests of coating efficiency vs gun voltage for different powder feed rates. At a feed rate of 5 gram/sec, the maximum coating efficiency possible is about 60%. On reducing the feed rate to the low value of 0,2 grams/sec the coating efficiency can be as high as 90%. * In order to maintain a constant coating efficiency the powder feed rate must be controlled and maintained. In the commercial systems available, maintenance of constant powder feed rate is not possible.

31.10. Areas for Further Work and Future Trends

The newer types of coating systems that are now being introduced appear to go a long way towards improving many of the limitations of standard gun systems. These next generation, tunnel type systems overcome the inherent low charging characteristics of old gun systems in two important ways.

1. The powder feed rate per gun is very much reduced hence instantly improving charging efficiency at the gun.
2. Uncharged or oversprayed particles are offered additional opportunities of being charged by post charging electrodes situated downstream in the booth.

1. The powder feed rate per gun is very much reduced hence instantly improving charging efficiency at the gun.

2. Uncharged or oversprayed particles are offered additional opportunities of being charged by post charging electrodes situated downstream in the booth.

32. GUN PERFORMANCE

32.1. Abstract

This section will discuss the several parameters by which powder gun performance is defined and their inter-relationship from a theoretical viewpoint. The discussion will then show what the practical limits on each parameter are, which are most important from a user standpoint and how variations in each parameter affects system design and performance in an actual coating system.

32.2. Discussion

There has been a considerable amount of rhetoric by the equipment manufacturers on the performance of their powder spray guns, principally in the areas of transfer efficiency and flow rate. Since there are no standardised tests for these parameters, each manufacturer has devised tests which he feels are representative and will give meaningful data to be used in product development and ultimately in advertising. As in all properly designed experiments, these performance tests require close adherence to the test procedure to assure repeatability and validity of data comparisons. This means that the object being coated is closely controlled, a situation that does not occur in a production plant. One would therefore have to establish the difference between field performance of powder equipment and laboratory testing.

The two laboratory parameters which are most often used as figures of merit are :

32.2.1. Transfer Efficiency

Defined as the percentage of total powder sprayed which remains on the target. It is affected by powder flow rate, pattern, target geometry, spacing and ground powder chemistry, humidity and particle size, conveyor speed, ratio of powder to air and electrostatic voltage.

32.2.2. Flow Rate

Defined as the weight flow of powder per unit time usually expressed as Kg/hr. It is affected by ejector pressure, air dilution of the powder, feed tube diameter, length and routing and the chemistry and humidity of the powder. (App. 113)

In the production field things are different, however and the two parameters that the production people are interested in are :-

32.2.3. Production Rate

Expressed as pieces per shift, it is a function of part size, method of transporting, conveyor speed and reject rate.

32.2.4. Cost

The cost to coat one piece. Can production be met on one shift? What is the reject rate? How high are maintenance costs? How much material is lost? In the production environment the powder gun becomes a tool. Powder guns from all the major manufacturers have a number of common features. They all have variable voltage, means to adjust the spray pattern, variable powder flow, a provision for controlling the air dilution of the powder and all are fed from a remote feeder by a flexible hose and a jet pump. There are as many differences as similarities, but in terms of those factors which affect production and cost, all are similar.

With recycling of powder the rule in large systems and very common in small systems, transfer efficiency very definitely becomes a secondary consideration to flow rate.

It should be noted that transfer efficiency does not drop off nearly as fast as flow increases so that more powder will be deposited per unit time and the production rate will be up if flow is increased. There are, however, some practical upper limits beyond which increased flow buys nothing.

Variables which have been encountered and dealt with while experimenting and their effects are listed below :-

TABLE 7

Effect of Variables on Transfer Efficiency

Variable	Effect
Flow rate	Increased flow generally decreases transfer efficiency
Pattern	Broader patterns show high efficiency unless the pattern is larger than the target
Target spacing	On a conveyor test widely spaced targets will show lower efficiency than if closely spaced.
Target Geometry	Larger, flatter, more regular parts show better efficiency while small highly irregular parts or parts with large open spaces show lower efficiencies.
Target Ground	Poor ground will reduce efficiency.
Air Dilution	More diffuse pattern improves charging and improves efficiency.
Powder Chemistry	Much data is proprietary. Powder can be 'doctored' increasing conductivity and reducing efficiency.
Power Humidity	Higher moisture content reduces efficiency
Particle size	Principle effect is through effects on flow rate and pattern. Smaller particles have higher ratio of aerodynamic to electrostatic forces. Larger particles have higher ratio of inertial to electrostatic forces.
Conveyor Speed	Some motion reduces self limiting effects, high speeds create aerodynamic disturbances - also true of reciprocator
Voltage	High voltage improves efficiency.

TABLE 8

Variable	Effect
Ejector pressure	Higher pressure raises flow
Air dilution	More dilution air reduces flow
Feed tube diameter	Larger tube increases flow
Feed tube length	Longer tube decreases flow
Feed tube routing	More bends decrease flow
Powder chemistry	Flow is adversely affected by a tendency to agglomerate - can also be due to triboelectric charging which is also affected by chemistry.
Powder Humidity	Higher moisture content reduces flow

33.3. Technical Basis for Product Requirement

Although the Spengler line of products includes a number of devices, the primary product is an ionisor bar which is used to eliminate static.

Understanding it, as well as the other products, requires some knowledge of the cause of the problem. Static is caused by the interaction of a material and the machine which processes the material. Both are composed of atoms each consisting of a positively charged nucleus around which negatively charged electrons are turning. In a neutral state, the charges are compensated. As a result of friction, pressure, changes in temperature, electrons may be added or become detached. The equilibrium is lost and the body shows an electrostatic charge. A surplus of electrons creates a negative charge and a lack of electrons creates a positive charge. Unavoidable accompaniments of the static are magnetism, the safety hazard of shock and trouble. Neutralisation can only take place if the electrons are added or led away. In the case of electrically conductive material, this can be achieved by grounding the material. The neutralisation of non conductive (dielectric) materials is, however, considerably more difficult and represents the greatest part of the need for ionising devices.

Static is always caused by non conductive equipment and the amount of the static charge is based on the dielectric content of the material. Synthetic materials have a high dielectric content than natural materials such as pure cotton. So called surface charges, which are mainly generated by friction, can partially be eliminated with grounded conductors if the charged bodies are thin. Bodies which are heated and then cooled off during the working process, however, develop a high static charge generated by the intermolecular friction which cannot be simply eliminated by surface contact.

Some form of ionising device must be employed to lead off the charge. There are two kinds of ionising devices : active and passive. Active refers to the neutralisation of the electrostatic charge, and passive refers to the elimination only of the safety hazard of shock.

All grounded conductors for example are passive ionisers. Active ionisers in addition produce an ionisation effect near, in or around the material to lead off the charge.

33.4. The Spangler (SR) Ionisor

This is the only known one in the United States which is both active and passive. It can be attached to nearly any static producing process and creates a strong concentrated electrostatic field aimed at the charged material. It is able to produce several active fields with the same equipment so that any desired neutralisation effect can be achieved. It is completely shock proof and spark free and is strongly built to last indefinitely.

It can be built in any size and comes with a range of peripheral products to solve virtually any static problem.

33.5. Some of the facts and Characteristics of Ionisation

Passive ionisation is accomplished by placing grounded points in the immediate area of the charged material.

Active ionisation may be accomplished by placing high voltage points (AC or DC) in the immediate area of the charged material. This has the effect of neutralising medium voltage electrical charges. Unfortunately this type of device has exposed high tension and will cause electrical shock upon contact. Even with capacitive coupling, there is no assurance that the unit will be shock proof. Most manufacturers place this high tension field behind metal guards with slits, holes or open channels.

These shields create an opposing polarity screen and in spite of the high voltage, they reduce the power of the neutralising field being emitted as well as the distance in which it can be effective. These devices are not spark free. The ideal situation would be to have a combination of passive and active ionisers making use of both qualities. This has been accomplished in the S.R. ionisers.

33.6. Description of the SR Ionisor

The SR Bars provide a strong vertical and active field applied at grounded points, whose polarity changes with the frequency of the alternating current. Two high tension poles (wires embedded in insulating epoxy) have been moved upward and inward (relative to previous techniques) which results in a more active field with only an 18° open angle (see figure 13). The system, with exception of the tungsten steel alloy ground pins, is embedded in insulating epoxy resin. This design is the basis of the SR ionising system. Another great value of this system is its ability, through its unique radiator design, to be expanded from a type I (single power bar) to a type IV (quadro power bar).

As speed increases the air flow tends to bend the static field in the direction the material is running. With a single bar producing an ion field at the rate of 60 positive (+) and 60 negative (-) per second, there are many situations where the field will completely cover the material passing through it. For example : too far away as in Fig 13 passing at too high speed so that the ion fields produced per second are not sufficient. In addition, if the voltage is very high it will take a larger more powerful field than a single bar can produce with the ability to increase the number of active fields from I to IV (figure 14). So speed voltage and distance from the web (material) determine which number SR bar to be used.

These shields create an opposing polarity screen and in spite of the high voltage, they reduce the power of the neutralising field being emitted as well as the distance in which it can be effective. These devices are not spark free. The ideal situation would be to have a combination of passive and active ionisers making use of both qualities. This has been accomplished in the I.P. ionisers.

33.6. Description of the SR Ionisor

The SR Bars provide a strong vertical and active field applied at grounded points, whose polarity changes with the frequency of the alternating current. Two high tension poles (wires embedded in insulating epoxy) have been moved upward and inward (relative to previous techniques) which results in a more active field with only an 18° open angle (see figure 13). The system, with exception of the tungsten steel alloy ground pins, is embedded in insulating epoxy resin. This design is the basis of the SR ionising system. Another great value of this system is its ability, through its unique radiator design, to be expanded from a type I (single power bar) to a type IV (quadro power bar).

As speed increases the air flow tends to bend the static field in the direction the material is running. With a single bar producing an ion field at the rate of 60 positive (+) and 60 negative (-) per second, there are many situations where the field will completely cover the material passing through it. For example : too far away as in Fig 13 passing at too high speed so that the ion fields produced per second are not sufficient. In addition, if the voltage is very high it will take a larger more powerful field than a single bar can produce with the ability to increase the number of active fields from I to IV (figure 14). So speed voltage and distance from the web (material) determine which number SR bar to be used.

Figure 13

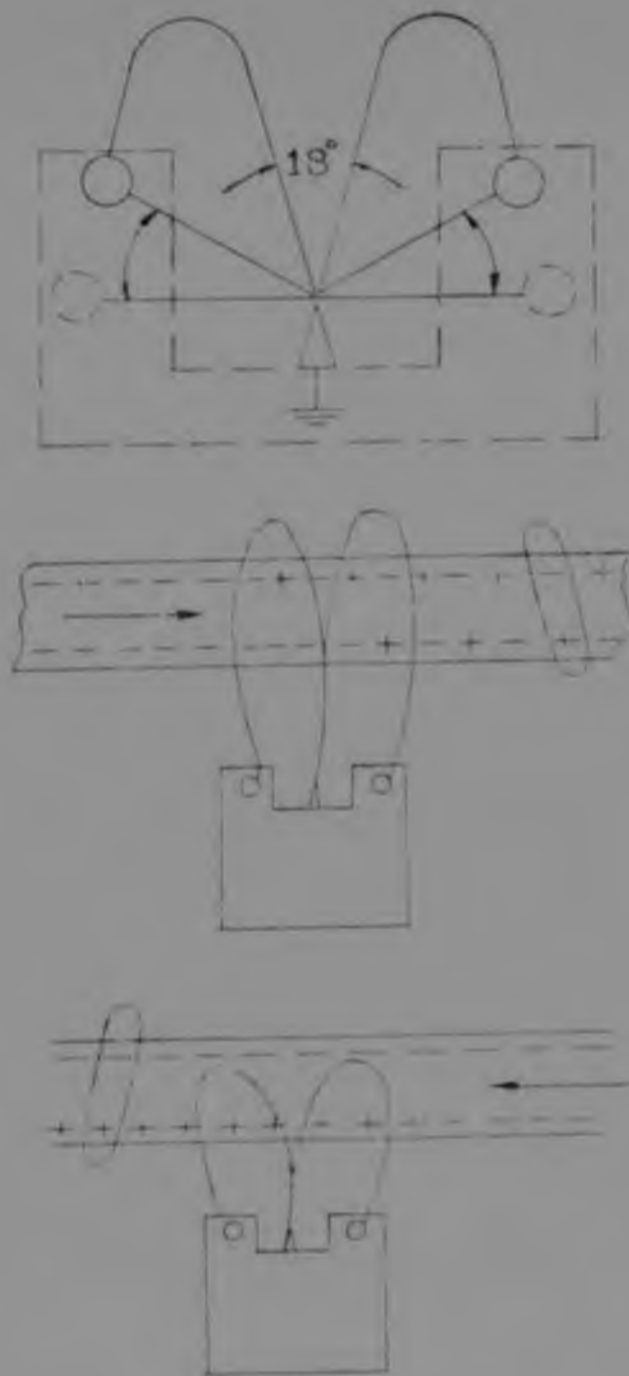

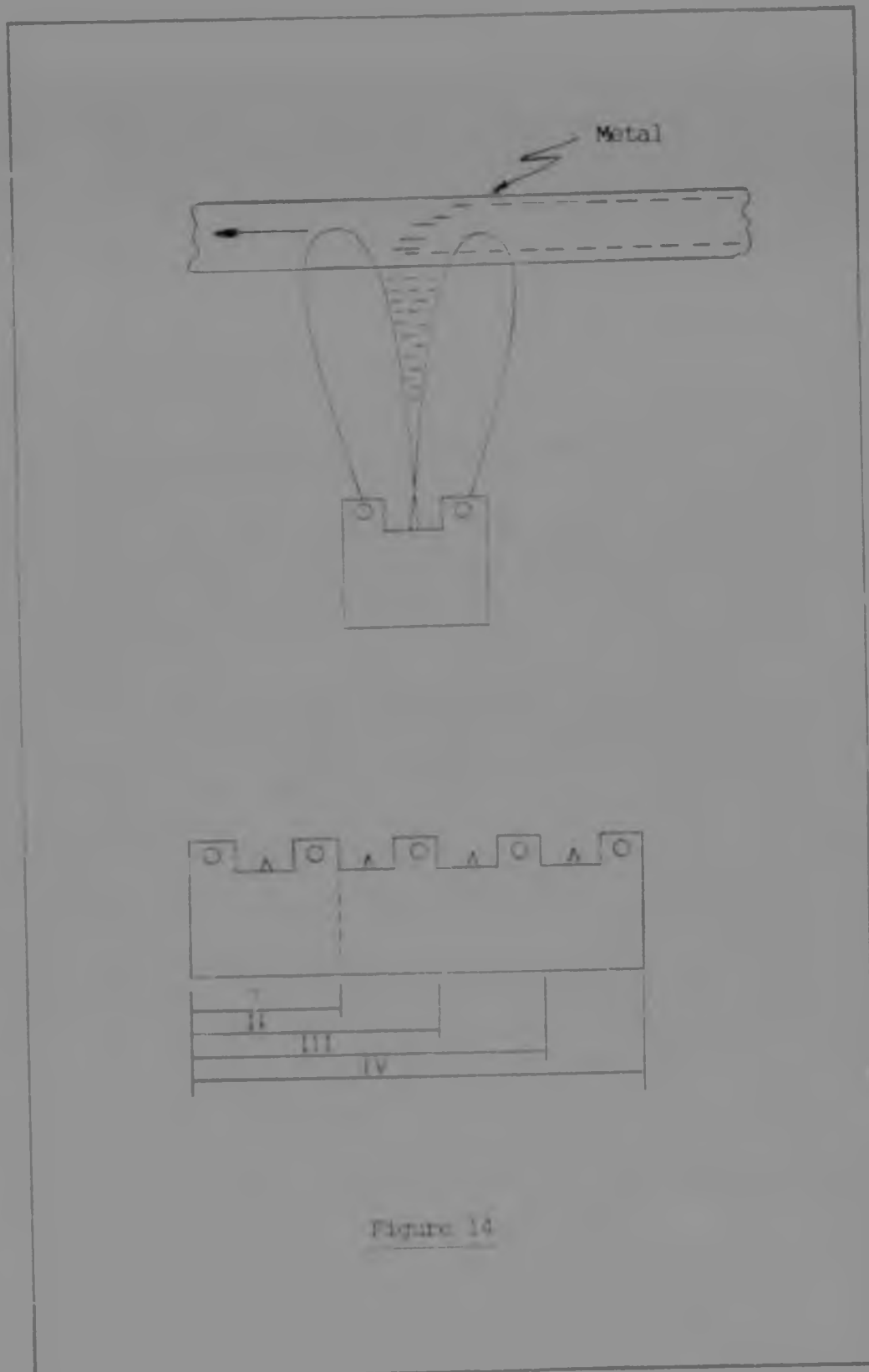

Figure 14

As it can be noted in Figure 13 it is best to place the bar as close as possible to the web keeping in mind the optimum distance is between 19mm and 40mm (ref *).

From an operational standpoint, SR bars perform at their peak efficiency on 8300 volts. The transformers have several settings to achieve this voltage. If the voltage on the line is to be measured it is done with all bars 'on line' because the voltage output on the secondary side of the transformer increases as the length of bar attached increases and vice versa. Therefore, the only true reading is with the whole system in operation.

33.7. Information About the SR System

1. The needles, made of a special tungsten steel alloy, are long lasting and maintenance free with the exception of periodic cleaning.
2. These needles are placed only 9,5mm apart and, therefore cover the total field, both longitudinal as well as transversal positions.
3. The power field of the SR ionisor is approximately 8 500 volts.
4. The SR system can penetrate material up to 4mm thick and may, therefore, be positioned on either side of the material and remove the static from both sides with a single bar.
5. This system is effective at both short and long distances from the material (up to 250mm).
6. The SR bar is rust and corrosion proof.

7. The SR system provides an actively open end directed field of ionisation with an open angle of only 18° .
8. The system combines the advantages of active and passive ionisation.
9. The ion field produced by the SR bars neutralises the problem area static field by producing sufficient positive and negative ions to match up with their opposites with those going to ground.

33.8. Electrostatic Grounding

The objects to be coated are carried into the spray booth on a grounded conveyor chain. There an electrostatic spray gun is used to coat them with powder. Even assuming the object is properly enveloped in powder, the following conditions have to be met to obtain a uniform coat.

- a) The direction and strength of the electrostatic field have to be properly adjusted.
- b) The powder feed rate must be suitably metered.
- c) The powder cloud has to move at the right speed
- d) The object being coated has to be hung from the conveyor chain in such a way that it is properly grounded.

As the overhead conveyor passes continuously through the spray booth, each hook receives layer after layer of powder, which means there is no longer any assurance that the objects will be properly grounded.

If they are not the powder cloud can become irregular and the coating uneven. Moreover the danger of an explosion cannot be ruled out. The performance proven SR ionisor is capable of solving this grounding problem.

Function of the SP Ionizer

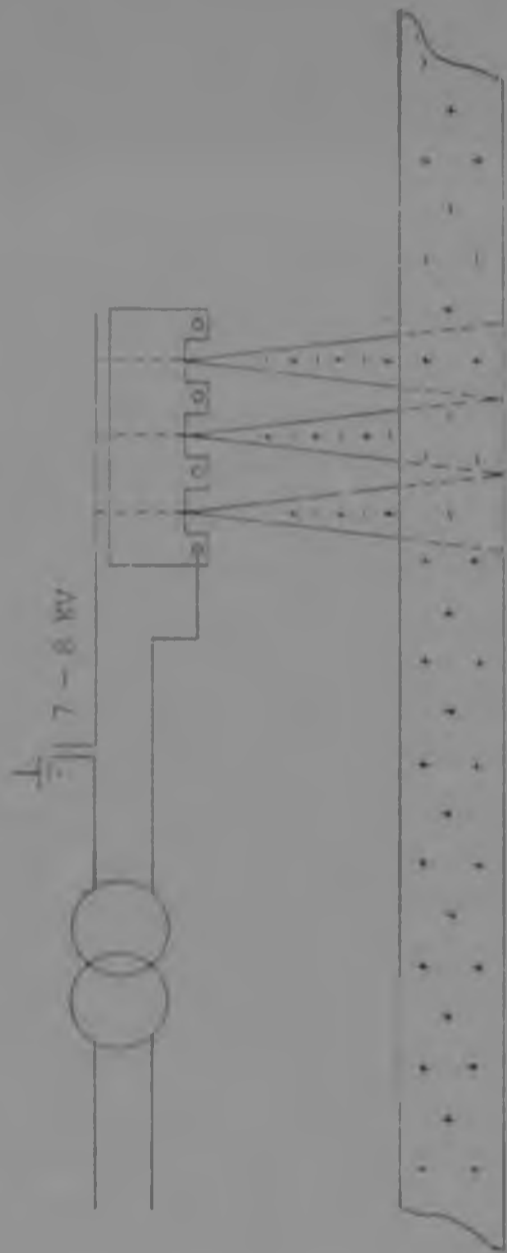

Figure 15

Function of the SR Ionisor

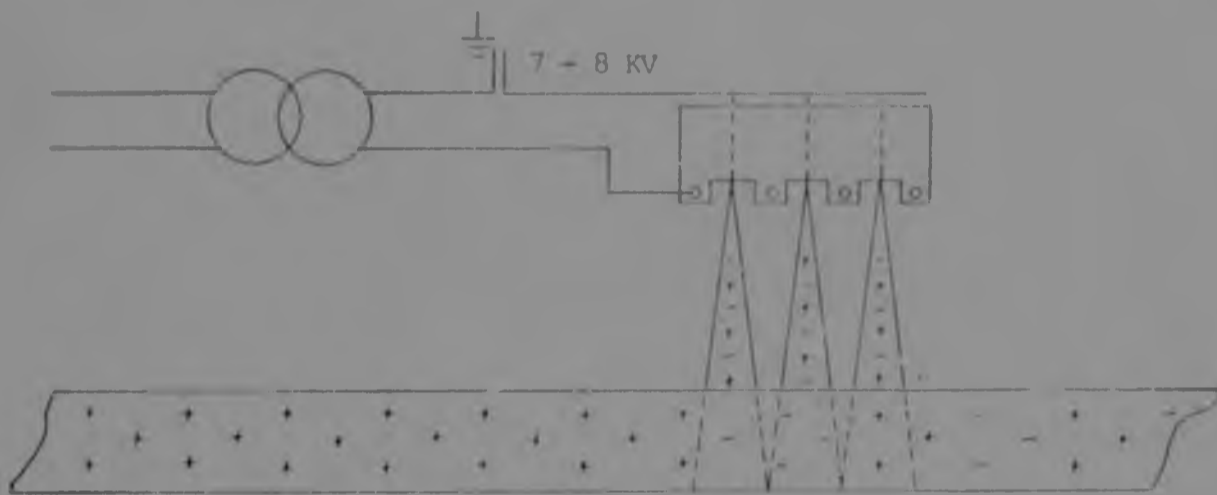

Figure 15

33.9. Operation

Theoretically, the objects carried into the spray booth should be grounded through the hangers, so that the SR ionisors are only needed to provide contactless earthing in cases where the flow of electrons in the hanger is blocked either partially or completely. But the SR ionisor is capable of assuring the grounding of the objects regardless of the condition of a particular hanger.

This fact opens up an entirely new approach to electrostatic powder coating.

The objects are introduced to the booth deliberately insulated. The grounding effect provided by the SR ionisor can be increased or decreased at will by adjusting its distance to the object. The air between object and ionisor which is made conductive by ionisation, has an electrical resistance that varies with this distance. Changing the distance, then, slows down or speeds up the rate of removal of the electrons induced on the object by the spray gun.

This effect makes it possible to coat more evenly because ideal powder envelopment is assured. The speed of the powder cloud can be matched to this conductive effect so that just the desired type of finish is obtained. If desired, a grounding monitor can be incorporated in the control unit to provide a continuous reading of ignition energy and to shut down the entire coating installation should a certain limit (normally 5 MJ) be exceeded. This monitoring attachment can either be installed stationary or supplied as a mobile unit. The necessary SR ionisors can be mounted on an adjustable frame. The powder supply and self monitoring are taken care of by a control unit in a dust proof enclosure.

SR ionisors are approved and certified for use in explosive gas atmospheres, thus providing a maximum of safety.

33.9. Operation

Theoretically, the objects carried into the spray booth should be grounded through the hangers, so that the SR ionisers are only needed to provide contactless earthing in cases where the flow of electrons in the hanger is blocked either partially or completely. But the SR ioniser is capable of assuring the grounding of the objects regardless of the condition of a particular hanger.

This fact opens up an entirely new approach to electrostatic powder coating.

The objects are introduced to the booth deliberately insulated. The grounding effect provided by the SR ioniser can be increased or decreased at will by adjusting its distance to the object. The air between object and ioniser which is made conductive by ionisation, has an electrical resistance that varies with this distance. Changing the distance, then, slows down or speeds up the rate of removal of the electrons induced on the object by the spray gun.

This effect makes it possible to coat more evenly because ideal powder envelopment is assured. The speed of the powder cloud can be matched to this conductive effect so that just the desired type of finish is obtained. If desired, a grounding monitor can be incorporated in the control unit to provide a continuous reading of ignition energy and to shut down the entire coating installation should a certain limit (normally* 5 MJ) be exceeded. This monitoring attachment can either be installed stationary or supplied as a mobile unit. The necessary SR ionisers can be mounted on an adjustable frame. The powder supply and self monitoring are taken care of by a control unit in a dust proof enclosure.

SR ionisers are approved and certified for use in explosive gas atmospheres, thus providing a maximum of safety.

34. CHARGE DECAY

Powder coating by the electrostatic spraying technique involves corona charging of powder particles followed by transport and deposition of the charged particles onto an electrically grounded surface. As long as the deposited particles retain their charge, oncoming particles will be deflected by the repulsive potential established by the deposited particles, and deposit in areas of lower potential or areas which are not yet coated.

This enhances the uniformity of particles deposition (10), but reduces the deposition efficiency (11) (12). The residual charge on the particles also assures that the particles will remain deposited for sometime, thus minimising loss of powder during the transport of the coated substrate to the baking oven. For polymers the rate of charge decay is influenced by the chemical composition (13), temperature (14) and relative humidity (15). In most powder coating spraying facilities the temperature and relative humidity are not controlled. Hence if the effects of temperature and relative humidity on the rate of charge decay are significant, periodical adjustments of the operating conditions of the spray guns will be required to compensate for changes in the ambient conditions and obtain proper particle deposition. The purpose of this section is to determine to what extent do the temperature and relative humidity influence the rate of charge decay of powders and what are the implications of the results with regard to the electrostatic spraying technique.

34.1. Review of Charge Decay

For a film of an ideal dielectric the decay of the surface voltage, V , which is proportional to the surface charge density by volume conduction is given by (16).

$$V = V_0 \exp (-t/\tau) \quad - (1)$$

where t is time and τ is the relaxation time of the decay process.

This mode of charge decay was observed by Shoshona for the decay of charge from rectangular polymeric sheets (13).

Several other researchers, however, did not observe a simple exponential decay. (17,18,19).

From a review of the literature it appears that the mode of charge decay depends on the mechanism of charge transfer, the geometry of the sample and the initial boundary conditions (20).

For powder coatings the decay of charge was studied recently by Cheever, who observed that the decay can be described by two exponential terms (21). The dependence of the rate of charge decay on temperature is given by (14)

$$\tau = \tau_0 \exp (E/K) - (2)$$

where E is the activation energy of the charge decay, K is Boltzman's constant and T is the absolute temperature. For most polymers the activation energy is the range of 0,4 to 2,7 electron - volts and is independent of temperature (22,23,24)

The effect of humidity on the rate of charge decay can be described by (13, 17, 25)

$$\tau = \tau_0 \exp (- b \cdot RH) - (3)$$

where RH is the relative humidity and b is a parameter which depends on the chemical composition of the polymer. Values of b, as reported by Shashona ranged from 0,004 to 0,3 for various polymers.

34.2. Experimental

34.2.1. Description of the Apparatus

The rate of charge decay was measured by continuously monitoring the decay in the surface voltage induced by the charged powder particles.

SURFACE CHARGE TESTER

Aluminium Box

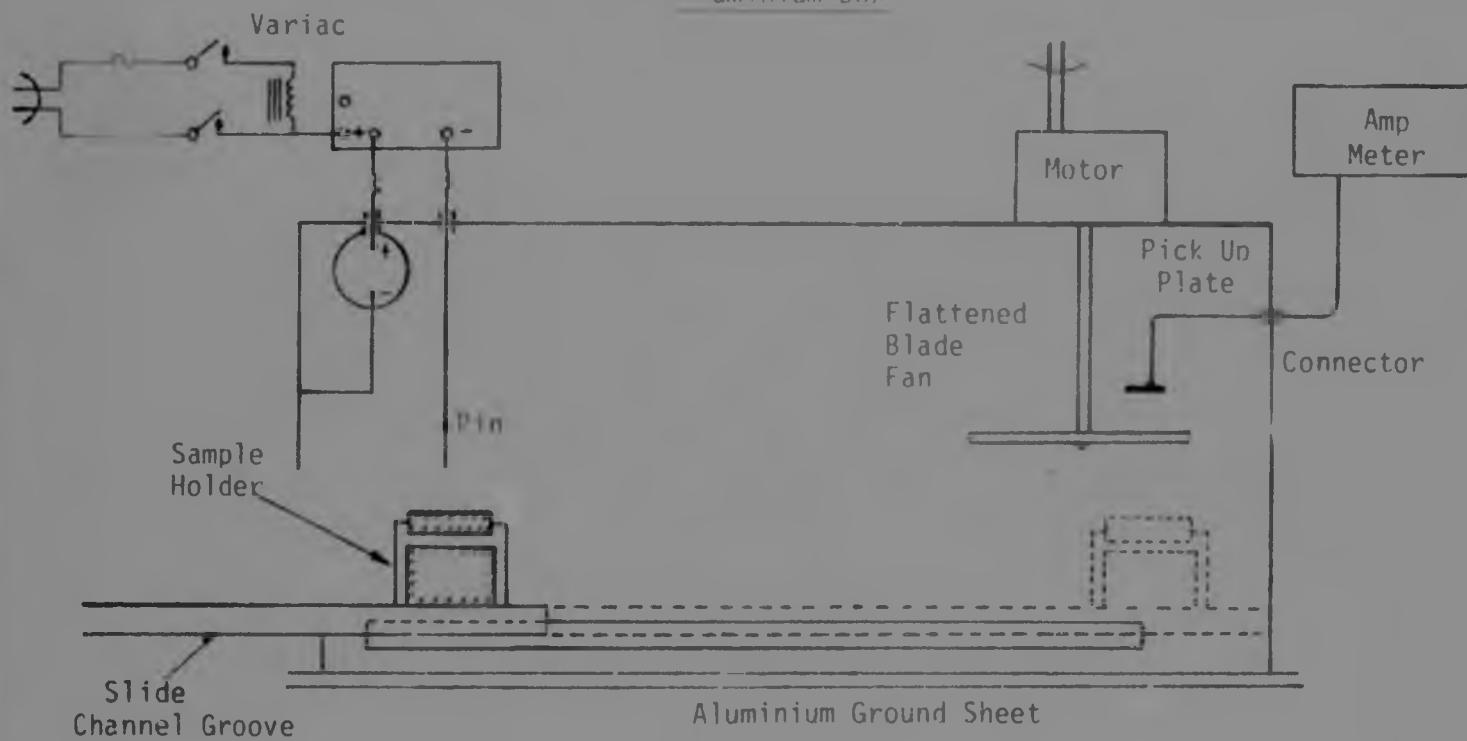

Figure 16

A schematic diagram of the apparatus for charging a powder sample and measuring the decay in the surface voltage is shown in figure 16. The apparatus has two stations. In the first station the powder which is placed in a grounded metal cup, 25mm in diameter and 1mm deep, is charged by a negative corona from a variable dc power supply. The corona needle is approximately 6mm above the powder sample.

After charging the sample is moved to the second station where the decay in the surface voltage is measured by a chopper technique: a flattened fan blade repeatedly shields a pick up plate from the charged powder sample; this converts the d.c. signal to an ac signal. The chopper frequency is 250 Hz. The capacitive current in the pick up plate is amplified, displayed on a meter and recorded. Calibration is achieved by replacing the powder with a metal surface of a known d.c. voltage.

To measure the decay in surface voltage under controlled temperature and relative humidity the apparatus was placed in an enclosed chamber. The temperature in the chamber could be varied between 0 to 54°C with an accuracy of $\pm 0,5^\circ\text{C}$. The relative humidity could be varied between 12 to 90% with an accuracy of $\pm 3\%$.

Epoxy polyester and polyester powders supplied by AECI were used in this study.

34.2.2. Procedure

Samples were prepared by filling the cup and leveling the powder surface without pressurising the powder. The sample was then placed inside the chamber and exposed to the present conditions in the chamber for 12 hours prior to testing. (Research Inc. U.S.A. facilities).

To charge the powder sample the corona voltage was monitored at 5KV. Too high corona voltage resulted in arcing and powder blow off. The corona current varied between 20 to 50microA depending on the temperature and relative humidity in the chamber. The charging time was approximately 0,5 seconds. This was found to be sufficient time to obtain saturation charge on the powder. After charging the sample was moved to the second station in about 1 second and the decay in the surface voltage continuously monitored for three hours. During that period the powder to the corona wire was disconnected since the presence of air ions influences the rate of charge decay.

34.3. Results and Discussions

34.3.1. Charge Decay of Various Powders

Semilographic plot of a typical decay of the surface voltage with time for an epoxy polyester coating is shown in figure 17 by the solid line.

From this decay curve it is seen that equation (1) may be used to describe the long term decay but not the initial decay.

It was found that the initial and the long term decay can be described by a combination of two exponential terms.

$$V = V_1 \exp(-t/\tau_1) + \frac{1}{2} \exp(-t/\tau_2)$$

The first exponential term represents a fast decay process which dominates the initial charge decay. The second exponential term represents a slow decay process which dominates the long term charge decay. The contribution of the fast decay process to the overall charge decay is determined by extrapolating to $t = 0$ the slow decay process, then subtracting the extrapolated values from the observed values of the surface voltage.

To charge the powder sample the corona voltage was monitored at 5KV. Too high corona voltage resulted in arcing and powder blow off. The corona current varied between 20 to 50microA depending on the temperature and relative humidity in the chamber. The charging time was approximately 0,5 seconds. This was found to be sufficient time to obtain saturation charge on the powder. After charging the sample was moved to the second station in about 1 second and the decay in the surface voltage continuously monitored for three hours. During that period the powder to the corona wire was disconnected since the presence of air ions influences the rate of charge decay.

34.3. Results and Discussions

34.3.1. Charge Decay of Various Powders

Semilogarithmic plot of a typical decay of the surface voltage with time for an epoxy polyester coating is shown in figure 17 by the solid line.

From this decay curve it is seen that equation (1) may be used to describe the long term decay but not the initial decay.

It was found that the initial and the long term decay can be described by a combination of two exponential terms.

$$V = V_1 \exp(-t/\tau_1) + \frac{1}{2} \exp(-t/\tau_2)$$

The first exponential term represents a fast decay process which dominates the initial charge decay. The second exponential term represents a slow decay process which dominates the long term charge decay. The contribution of the fast decay process to the overall charge decay is determined by extrapolating to $t = 0$ the slow decay process, then subtracting the extrapolated values from the observed values of the surface voltage.

Epoxy Polyester 45°C
14% Relative Humidity

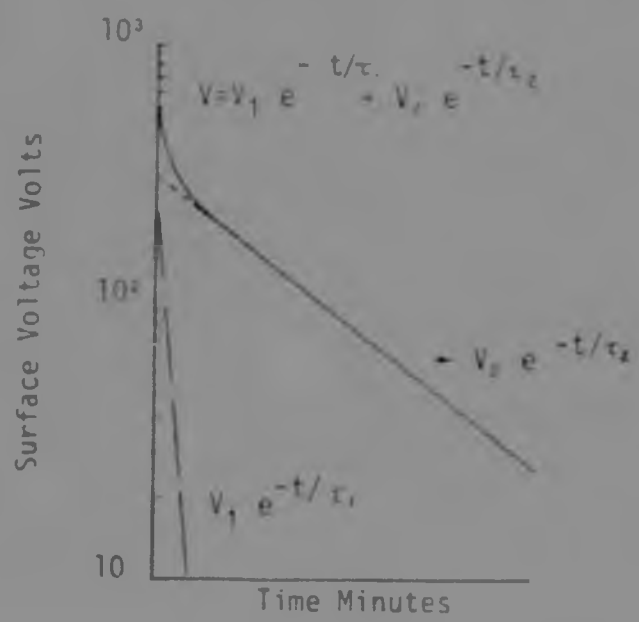

Figure 17

Epoxy Polyester
 14% Relative Humidity

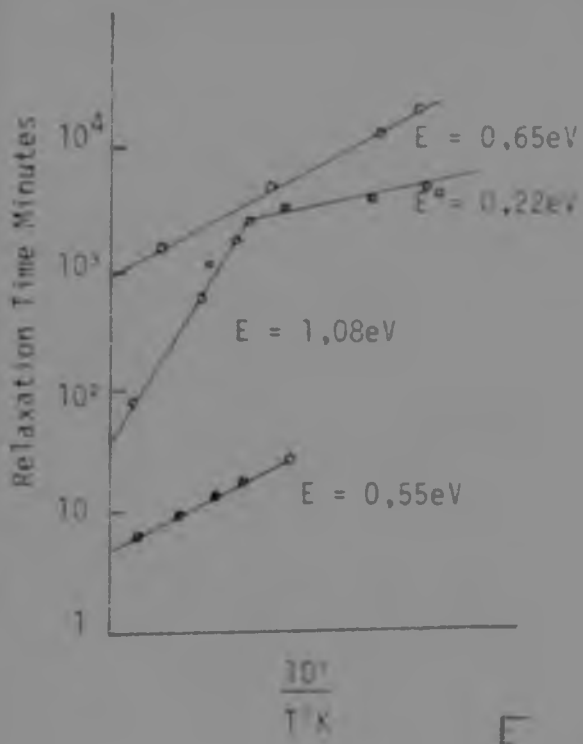
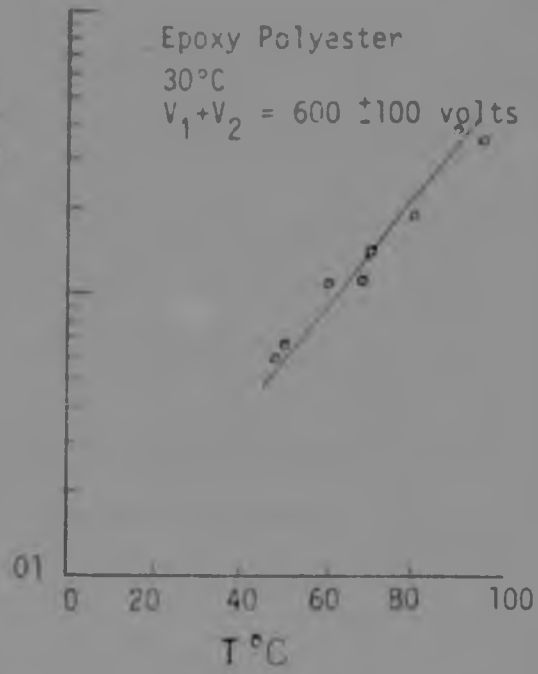

Figure 18

Figure 19



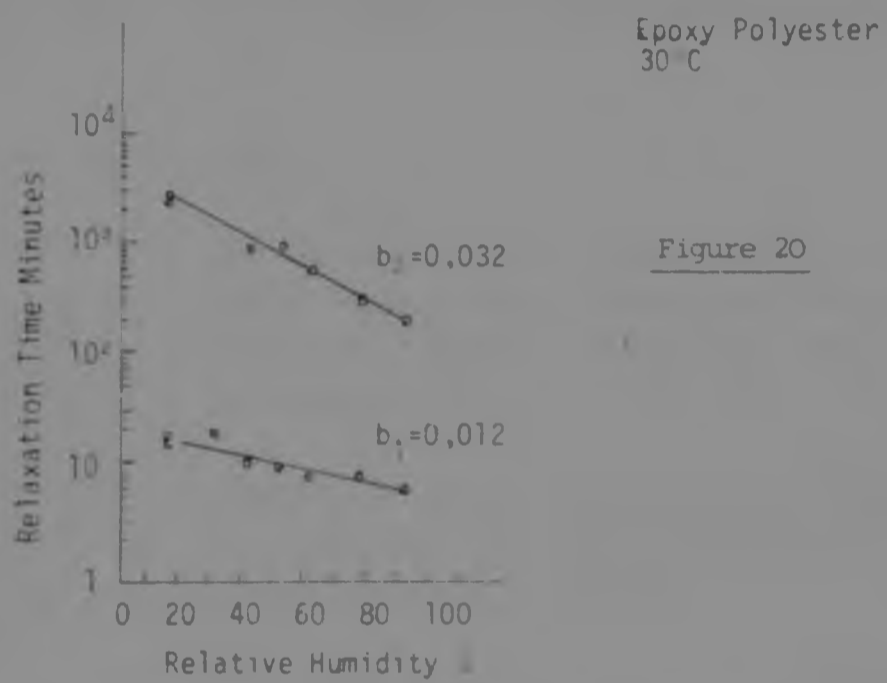

Figure 20

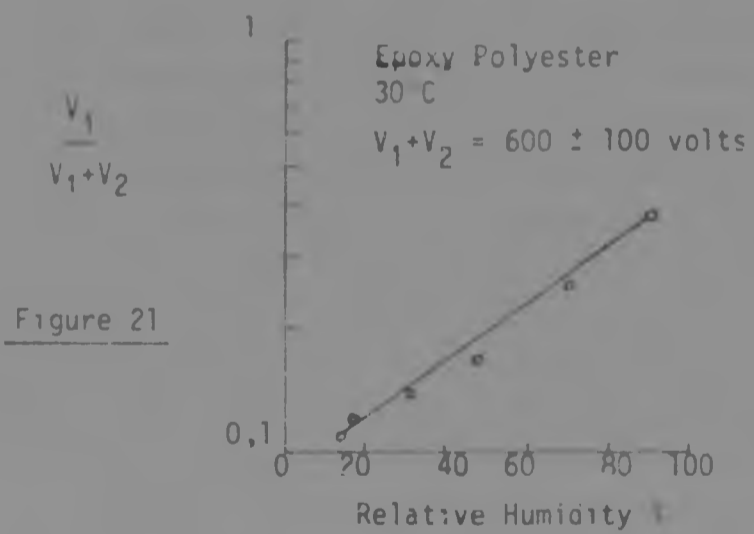

Figure 21

This mode of charge decay was observed also by Cheever (22). The same mode was also observed for the decay of charge from polyester powder. The relaxation times and the initial voltages for the decay of charge from these powders are listed in table

34.3.2. Temperature

The influence of temperature, between 0 and 50°C on the relaxation times of epoxy powders is shown in figure 18. Line A is a plot of τ_2 of a pure powdered epoxy polyester polymer versus $1/T$.

Lines B and C show, respectively the dependence of τ_2 and τ_1 of a fully formulated epoxy polyester powder coating on temperature.

The influence of temperature on τ_1 of the pure powdered polymer and on that of the fully formulated powder coating below 25°C is not shown because V_1 , the voltage corresponding to the fast decay process, was too small to be detected with sufficient accuracy. The activation energies corresponding to Lines A and C are 0,65 and 0,55 ev respectively.

In line B two activation energies are observed, below about 30°C the activation energy is 0,22 ev and above that temperature it is 1,08 ev. Since the activation energy of pure polymers is independent of temperature, it is believed that the change in the activation energy of the fully formulated powder with temperature is due to the presence of low molecular weight additives in the powder.

The same temperature dependence was also observed when low molecular weight additives, but not pigments were added to the pure polymer. As the temperature is increased above approximately 35°C, a larger fraction of these additives melt. Upon melting, they may migrate and form distinct phases of low electrical resistivity on the surface and/or in the bulk of the particles.

The formation of such phases is supported by the fact that the rate of charge decay at room temperature of a powder which has been exposed to elevated temperature is markedly faster than that of an unexposed powder. For example, at 25°C the values of T_1 and T_2 of a powder which was exposed to a temperature of 50°C for one hour are 7 and 250 minutes, respectively compared with 25 and 3300 minutes for the unexposed powder.

The temperature also influences the relative values of

$$V_1 \text{ and } V_2 .$$

A semilogarithmic plot of $V_1/V_1 + V_2$ vs temperature is presented in figure 19. As can be seen, the relative contribution of the fast decay process to the total charge decay increases with temperature. Between 25 and 50°C, the relationship between $V_1/V_1 + V_2$ and temperature is given by $\log \frac{V_1}{V_1 + V_2} = a_1 T + a_2$ - (5)

where a_1 and a_2 are constants. From figure 19 we obtain that $a_1 = 0,085^\circ\text{C}^{-1}$ and $a_2 = -4,5$

4.3.3. Relative Humidity

Figure 20 shows the influence of relative humidity between 14 and 90% on T_1 (line A) and T_2 (line B) of a fully formulated epoxy - polyester powder.

Both τ_1 and τ_2 decrease exponentially with relative humidity according to equation (3).

The value of the parameter b corresponding to τ_1 is 0,012 and that of b_2 corresponding to τ_2 is 0,032.

These values are in good agreement with values reported in the literature for polymers of similar chemical composition. Based on data reported recently by Cheever (22) we calculated the parameter b_2 , corresponding to the slow decay process, to be in the range of 0,02 to 0,04, in good agreement with the value of 0,032 found in this study. The influence of relative humidity on is shown in figure 21. As can be seen the contribution of the fast decay process to the total charge decay increases with relative humidity.

The functional relationship is given by :

$$\log \frac{V_1}{V_1 + V_2} = a_1 (RH) + a_2 \quad (6)$$

where a_1 and a_2 are constants. Based on the data in figure 21 we obtain that $a_1 = 0,017$ and $a_2 = -2,47$

34.3.4. Charge Decay and Particle Deposition

When one is concerned with the practical significance of the influence of the rate of charge decay on particle deposition, most important is the initial rate of charge decay since in practice the substrate is usually coated within a few seconds.

The long term decay becomes important when one is concerned with the electrostatic adhesion of the particles to the surface after spraying and prior to baking. It has been shown that the deposition of electrostatically sprayed powders can be assessed by the coefficient of deposition b (10,28).

This co-efficient is given by :

$$b = b_0 (1 + C_4 W V^2)^{-1}$$

where b_0 can be approximated by :

$$b_0 = C_1 \frac{aV^4}{dZ_0^2}$$

In these equations C_1 and C_4 are parameters which depend on type of equipment (28) and powder characteristics. W is the weight of the deposited powder, a is particle radius as obtained from number average particle size, V is charging voltage, Z_0 is spraying distance and d is the deceleration of the velocity of the carrying air toward the surface.

Of particular interest to the present discussion on the influence of chemical composition, temperature and relative humidity on particle deposition is the parameter C_4 . The term $(1 + C_4 W V^2)^{-1}$ is a dynamic term which reflects the increase in the amount of charges on the surface as more powder is being deposited. The value of C_4 is influenced by the initial charge on the deposited particles and by the rate at which the charge is being dissipated. Values of C_1 and C_4 for epoxy, polyester and epoxy polyester powders are given in table 10.

As can be seen the values of C_1 of these powders are about the same. This means that under equivalent spraying conditions the initial deposition pattern of these powders will be similar (10).

Despite the difference in the initial rate of charge decay of the various powders tested (table 9) there is no significant difference in their C_4 values. These powders behaved similarly when sprayed under the same conditions.

It was also found that when the epoxy polyester powder was sprayed at various ambient temperatures ranging from 24 to 33°C and corresponding to a change in T_1 from 27 to 14 minutes and in the relative contribution of V_1 from 6% to 12%, there was no significant change in the value of C4.

Similarly, variation in the relative humidity between 45 to 63%, which correspond to a change in T_1 from 11 to 9 minutes and in the relative contribution of V_1 from 18% to 25%, did not affect C4. These results suggest that when T_1 is of the order of several minutes a change by a factor of 3 to 4 in it would not have a pronounced effect on particle deposition during electrostatic spraying. This is not surprising if one considers the fact that the spraying process is completed within a few seconds which is not sufficient time for substantial charge dissipation. Calculated results of the surface voltage after 15 seconds assuming initial surface voltage of 600 volts are shown in table 11.

As can be seen, the change in the surface voltage under various ambient conditions is quite small. From the results of this study it is expected that seasonal variations in temperature and relative humidity would not have a pronounced effect on particle deposition of epoxy polyester powder. This conclusion is further strengthened by the fact that during spraying the powder is exposed to the ambient conditions for a very short time.

Although the above study has proven the foregoing some plants have claimed finding difficulties when operating at about 80% R.H. and specifically the one which is operational in the Ansul Company in America.

Specifically, the group production manager of the company claims that in the successful operation of a powder line humidity control is as important as cleanliness and at the present time, this is their most pressing problem. At the high R.H. they have found that powder is absorbing moisture and it begins clinging and caking. It agglomerates in the dust collector and will not pass through the screen in the vibrator screener. It hangs up in the dust collector and comes loose in chunks blocking the rotary valve and stops the return flow of the powder.

It is true though that problems of the severity mentioned above are a rarity and one could experience 6 or 7 operating days a year that are that severe.

Nevertheless their experience is something to keep in mind at this stage and to try and design for a dry air system in our plant.

TABLE 9

Charge Decay of Powder Coatings

(30°C - 40% R.H.)

<u>Type of Powder</u>	<u>t, Min</u>	<u>t, Min</u>	<u>V₁Volts</u>	<u>V₂Volts</u>	$\frac{V_1}{V_1+V_2}$
Epoxy Polyester	11	970	50	570	0,08
Epoxy	3	370	130	550	0,19
Polyester	3	600	40	640	0,06

TABLE 10

<u>Powder</u>	<u>C₁ KV⁻² sec⁻¹ cm⁻¹</u>	<u>C₂ g⁻¹ KV⁻²</u>
Epoxy Polyester	33	2,8x10 ⁻⁴
Epoxy	31	2,5x10 ⁻⁴
Polyester	33	2,7x10 ⁻⁴

TABLE 11

Surface Voltage after 15 Seconds

(V₁ + V₂ = 600 volts)

<u>Ambient Conditions</u>	<u>Epoxy Polyester</u>	<u>Epoxy</u>	<u>Polyester</u>
25°C, 14% R.H.	600	-	-
30°C, 14% R.H.	599	-	-
40°C, 14% R.H.	596	-	-
30°C, 40% R.H.	597	588	597
30°C, 80% R.H.	593	-	-

35.0 SYSTEM RELIABILITY

One could refer to reliability as being the quality the installation has to ensure reproductivity of the results for which it is started up and to guarantee continuous obtaining of these results.

It is one of the main qualities of an installation and the one which conditions its efficiency.

Reliability is a function of:

- Conception of the installation itself
- The reliability of the equipment forming the installation

The conception of the installation should respect the following criteria:

- Determination on the object to be coated, of the area to assign to each spraying nozzle in function of the thickness to be deposited and the advancement speed of the conveyor.
- Careful choice of the type of powder distributor hopper in function of the margin on the thickness to be deposited.
- Simplicity and clearness in positioning the various sprayers, in the movements to give these through the reciprocators.
- Control of the surrounding conditions under which the various equipments of the installation will have to operate.

In general, reliability depends on

- a) quality of elements used to manufacture the equipment.
- b) the interaction of the product to be applied and the equipment itself.
- c) the surrounding conditions.

35.1 Synthesis

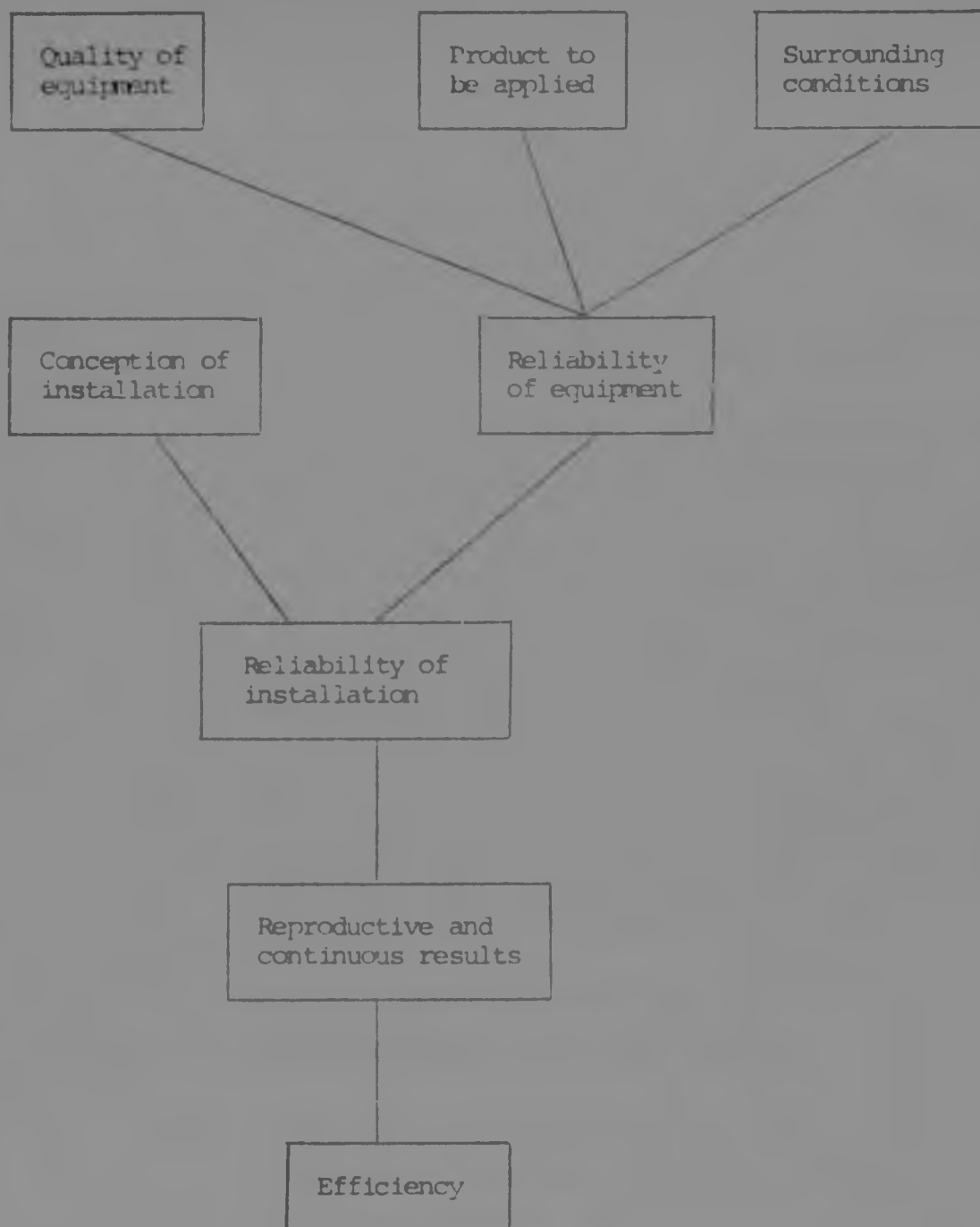

To elaborate extensively ...

35.2 Reliability

Interaction between the product to be applied and the equipment comes in two stages, one static and the other dynamic. If we take a chronological order to follow the way covered by the powder particles during an electrostatic application, we find successively:

- (1) A stocking period in the distributor tank : period with static prevalence.
- (2) A time of passing through a dosing device : dynamic period.
- (3) A time of transport in a hose : dynamic period.
- (4) A time of passing through a spraying nozzle where the particles collect their charge : dynamic period.
- (5) A time of "open air" transport between the spraying nozzle and the part to be coated : dynamic period, not the contact between the equipment and the product intervene, but the surrounding conditions.
- (6) Deposit on the part to be coated, very short time which stops the particle moving, or scattering of the particles in the atmosphere if they are not deposited on the part : period with dynamic prevalence.
- (7) Transport of the particles from the booth to the powder recovery unit : dynamic period.
- (8) Time of passing through the powder recovery unit : dynamic period when the particles are in contact with the recovery equipment and the booth ventilation air.
- (9) Recycling which sends the powder recovered into the distribution : dynamic period.

- (10) Mixing of the recovered powder and the new powder :
dynamic period where there is interaction of two
products which can be considerably different.

This enumeration shows off the fact that the particle of powder is successively under conditions which have an influence on its initial characteristics. Any alteration carried out during one of the phases of the installation operating will have an effect on the following phase.

For the reliability to be guaranteed, it is absolutely essential to be able to control the interactions between the product and the equipment, placed under set surrounding conditions, during each phase of the operating, and to see that these interactions do not cause alterations in the main characteristics of the paint in powder form used.

It is of first importance to study in a detailed way the restraints of all kinds that the particles of powder undergo during an application, restraints which can alter the fundamental characteristics of the product, and therefore perturb the operating of the installations. It is not possible to study all the restraints in the scope of this account but only the ones which are particularly important.

35.2.1 Time of passing through the dosing device

The powder contained in the hopper, fluidized or not, is sucked up in the venturi and then driven back into the transport hose. The injection air output speed can easily reach 800 Km/hr (222 m/s) for an injector with a diameter of 2mm, operating with an amount of 4 m³/hr. In the immediate proximity of the injector, a particle of powder can therefore reach a very high speed. If this particle meets the walls of the dosing device, there is an energy clearance of $\frac{1}{2} eV^2$, e being the earth of the particle and of its speed at the time of the collision. This energy clearance is sufficient to melt the particle

of powder on part of its surface. There can follow fixation of this particle of powder on the wall of the dosing device.

After operating time which can vary in function of the powders and of the dosing devices, these can be completely blocked up.

The powder output at the spraying nozzle is no longer ensured. There is no reliability. Even giving all the necessary care to realising the venturi, experience proves that the good operating of a venturi depends on the characteristics of the powder : softening point and granulometrical graph.

35.2.2. Time of Passing Through the Spraying Nozzle

The particles of powder take their charge in, or in the immediate proximity of the spraying nozzles. If the charge taking phenomenon is well known in the case of more or less conductive liquids such as paints, it is otherwise in the case of powders generally very insulating and the influence of the charge on the quantity deposited.

However, experience has proved that the thickness deposited on the part to be coated, with an equal powder output, with equal intensity and high voltage, for a set time, varied for a set powder epoxy resin based, in function of the temperature and the relative humidity in the powder coating booth.

One can see the great importance of controlling the surrounding conditions to obtain reliability of an installation by electrostatic powder coating.

35.2.3. Time of Transport Between The Spraying Nozzle and the Substrate

During the journey from the spraying nozzle to the part to be coated, the particles of powder are subject to the action of three main forces.



Figure 22

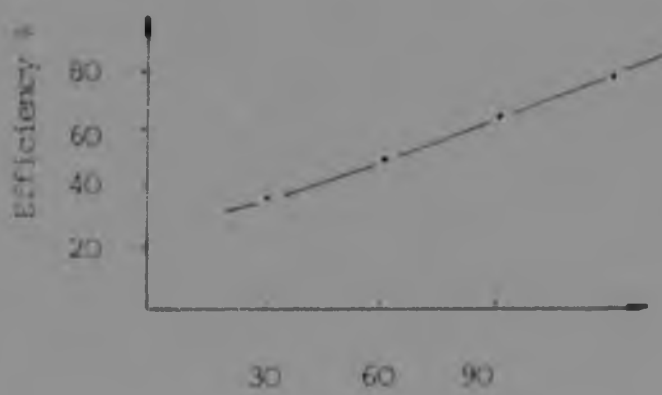

(kV) High voltage

Figure 23

- 19 -
- a) Action of the gravity : $F_1 = mg$
 - b) Action due to the current of transport air and to the ventilation of the booth : F_2
 - c) Action of the electrical field E created between the spraying nozzle and the part to be coated
 $F_3 = qE$, q being the charge of the particle.

One cannot act on F_1 and force F_2 is very badly known.

There is a general interest for it to be as low as possible. On the other hand, F_3 depends on the electrical field E , itself a function of the high voltage applied to the nozzle. Experience proves that the more one works with high voltage, the higher the efficiency that is the weight deposited/weight sprayed ratio and therefore the higher the reliability.

Conditions for Test

Epoxy	=	polyester clear powder
Output at the nozzle	=	210 g/min
Target	=	sheets of 500 x 500mm
Speed of the conveyor	=	2,5m/min
Distance between nozzle and target	=	300mm

36.0 PILOT PLANT DESIGN

Having examined the various parameters involved in a powder coating system, we felt in a position to be able to introduce our own conception of the process, as applied to our hardware range components, in the form of a pilot plant.

The following discusses the activities involved in installing such a plant, considerations and assumptions made, and the construction of the plant.

36.1 List of parameters for laying out a powder coating line

- 1) Details of product to be coated
- 2) Purpose of coating
- 3) Type of coating material
- 4) Production rate
- 5) Fixturing of articles
- 6) Type of surface preparation
- 7) Coating thickness
- 8) Application method
- 9) Type, number and requirements of ovens
- 10) Powder exhaust and recovery methods
- 11) Conveying mechanism and electrostatic grounding
- 12) Automatic coating application devices
- 13) Number of colours and colour changes required
- 14) Cool down time
- 15) Air replacement needs
- 16) Powder storage areas
- 17) Air requirements
- 18) Parts loading and unloading
- 19) Floor space and ceiling height available
- 20) Parts inspection and touch-ups
- 21) Stripping or repair of rejects
- 22) Applied coating costs
- 23) System cost
- 24) Justification for system
- 25) QC - quality control

36.2 Breakdown of activities involved in the installation of a powder coating line

- (1) Details of product to be coated (App. 11)
 - a) Sheet sizes
 - b) No. of different sheet sizes. Total no.
 - c) Scheduling for production of different sizes
 - d) Adjustments needed to be made when processing different sheet sizes
 - e) Time variation in curing different sheet sizes
 - f) Stacking and destacking - according to thickness or design or sheet size or type of product (tray - big etc).
 - g) Time variation in spraying different sheet sizes.

- (2) Purpose of coating
 - a) Resistance to wear and anti-corrosion
 - b) Further potential considerations
 - c) Cost consideration.

- (3) Type of coating material
 - a) Powder coating
 - b) Different types of powder
 - c) Curing time - optimum
 - d) Film thickness - optimum
 - e) Deposition efficiency - particle size.

- (4) Production rate
 - a) Exact time requirements per sheet size processed
 - b) Time allocation/day/size
 - c) Change-over time
 - d) Spraying time - optimum

- (5) Fixturing of articles
 - a) Feed rate synchronisation
 - b) Belt components
 - c) Stacking and destacking

- (6) Type of surface preparation
 - a) Effects on quality of spraying

- (7) Coating thickness
 - a) Effect on curing time
 - b) Calculation of spraying time and voltage of gun
 - c) Reciprocation of guns

- (8) Application method
 - a) Details of electrostatic spraying equipment, no. of guns

- (9) Type, number and requirements of ovens
 - a) Selection of oven (IR, gas)
 - b) Length and no. of lamps, transportation method
 - c) Energy consumption

- (10) Powder exhaust and recovery methods
 - a) Recycling
 - b) Belt cleaning
 - c) Filter bags, cyclones
 - d) Colour change effects

- (11) Conveying mechanism and electrostatic grounding
 - a) Electrostatic earthing positioning
 - b) Units required
 - c) Distance and length effects and size effect
 - d) Adjustment on conveying mechanism for different sizes
 - e) Speed of conveyor - hangover - size and oven speed

- (12) Automatic coating application devices
 - a) Automation and electrics.
 - b) Supports and controls

- (13) Number of colours and colour changes required
 - a) White and clear.
 - b) Application and sequence method
 - c) Hoppers for different colour powders
 - d) Shielding required.

- (14) Cool-down time
 - a) Intervals before handling
 - b) Stacking and destacking organisation

- (15) Air replacement needs
 - a) Filters
 - b) Cyclone
 - c) Air speed in booth - max and min requirements
 - d) Dust concentration

- (16) Powder storage areas
 - a) No. of hoppers - supply line

- (17) Parts loading and unloading
 - a) Stacking and destacking method - no damage - design
 - b) Sheet sizes - time calculation

- (18) Floor space and ceiling height available
 - a) Wynberg workshop
 - b) Calculations as to size of equipment

- (19) Parts inspection and touch-ups
 - a) When, where along line, how, how often
 - b) Touch-ups required

- (20) Fixtured and Conveying mechanism clean-up
 - a) Discussion with suppliers
 - b) Normal check-up - maintenance

- (21) Stripping or repair of rejects
 - a) Observation points
 - b) Safety stop - spray booth
 - c) When - interval for repairs.

- (22) Applied coating costs
 - a) Powder costs
 - b) Recycling costs
 - c) Cost-quality as optimum film thickness

(23) System cost

- a) Spray booth
- b) Electrostatic guns - reciprocators - hoppers
- c) Conveyor system
- d) Oven cost
- e) Feeding system
- f) Stacking and destacking
- g) Operators' costs
- h) Electrostatic grounding
- i) Cyclone, filters, recycling equipment
- j) Compressor

(24) Justification for system

- a) Cost and payback.

(25) Quality control

- a) Film thickness constant detection
- b) Deposition of powder and curing
- c) Discolouration
- d) Impact tests.

36.3 Pilot plant design considerations

Our objectives for a new finishing method are:

- (1) Reduce rejection rate (App. 7)
- (2) Retain or improve our quality reputation
- (3) Ensure availability of capacity to satisfy possible future requirements.

To achieve these objectives, we clearly needed to substantially look into developing our operation.

Some work had been previously carried out by one of our Development engineers in U.K., solely for the purpose of experimenting with a new product.

When MBSA decided to look into this alternative, material suppliers were advocating powder coating as a relatively simple application process which might meet our needs.

We began a serious evaluation of the possibilities of the powder coating process and powders as a solution to our own particular problems. Application of powder did seem amazingly simple. As we moved on from Powder Supplier's laboratory demonstrations to work with Equipment Suppliers' larger scale demonstration facilities our problems arose. There appeared to be very little knowledge or experience of powders and applications. It was now necessary to proceed on three fronts: (1) Development of the "best" powder for the job in clear colours

(2) Internal selling

(3) Design of a plant to apply powder, including finding somewhere to put it.

36.3.1 Powders

What we wanted was fairly clear - a rich, smooth, clear finish, without any pronouncement of orange peel, reproducible between 25 and 40 microns, usable in any mix of virgin and reclaim material, totally consistent from batch to batch, consistent appearance on different substrates.

It was also highly desirable we have two suppliers whose materials should be capable of intermixing.

It took at least 7 months, with many dissappointments, before a satisfactory powder was offered, which would offer very good all-round characteristics. The materials currently in use satisfy our requirements, with reservations on reproductivity at low film thickness.

We are continuing to seek a lower curing temperature material to save energy.

36.3.2 Internal selling

To ensure the success of the changes that were coming, we needed the co-operation and support of the shop floor personnel, who whilst prepared to accept the change, felt afraid of the unknown. To give us all the opportunity to find out about the realities of powder coating and strengthen our conviction, we bought a pilot installation - gun, booth, oven. This was invaluable to everyone involved and additionally enabled us to get a "feel" of the process.

We ran the plant for about a year, during which time we pursued main plant design.

36.3.3 Plant design

From components, quantity required, possible jiggling and spraying configurations, together with visits to other people's plants and plant manufacturers' demonstrations, we concluded that there is a need for a "continuous process" type plant.

Various considerations revealed that automatic application was suitable. The final layout sets the plant out in a straight line along one wall which allows the main area of the shop to be used for loading and unloading.

37.0 PILOT PLANT DESCRIPTION

Going through the facility, we see that the spray gun is mounted onto a reciprocating pneumatic cylinder transverse to the motion of the substrate.

A conveyor is provided to carry simulated workpieces lying flat on the heat-resistant belts, below the front of the spray gun. This conveyor is equipped with an accurate variable speed control to allow adjustment of the time the workpiece is exposed to the spray gun and the oven.

A spray booth is provided equipped with an air outlet.

Electrostatic grounding bars have been positioned below the conveyor belts so as to earth the substrate and prevent wrap-around of powder. Also some other target configurations are used for "eyeball" evaluation of such behavioural characteristics.

A laboratory balance is used to determine any weights required in this procedure.

An infrared oven is used to fuse the powder onto the sheets. The test procedure calls for a clear statement of the required conditions under which the determination is to be made. (App. 4,5)

The actual delivery rate through the gun is confirmed by collection and weighing of a sample.

Solids (non-volatile coating content) are determined by weighing a sample of the coating material in the condition received, baking it to drive off volatiles, and then re-weighing.

Actual voltage available at the spray gun is determined by measurement with an electrostatic kilovolt meter.

The foil to be used on the test sheets for collection of the coating is weighed very accurately and the weight recorded.

The powder flow through the gun is then started and the test workpieces are carried in front of the gun by the conveyor.

Substrate time of exposure to the gun as measured by the stop clock is then recorded. By using this time and the powder delivery rate previously determined, the actual amount of powder delivered during the workpiece exposure can be calculated.

The sheet is then moved on into the oven for fusing of the powder. After thorough bakeout and cooling, the foils are removed from the workpiece, carefully folded to avoid loss of coating and again weighed at the analytical balance.

Transfer efficiency is calculated from the data gathered above.

Typical test results in graphic form can show several relationships. We have, up to this point, found that:

- (a) Efficiency goes up as voltage is increased
- (b) Differences do exist in the behaviour of different powders
- (c) Transfer efficiency decreases as the spray gun delivery rate increases
- (d) Distance between spray gun and target was varied to evaluate effect upon transfer efficiency. Test was conducted at two different voltages and showed, at least for the spray gun and powder evaluated here, that an optimum spray distance exists somewhere in the range of 300 mm.



LAYOUT



VARIABLE SPEED CONVEYOR

KNOB READING

VELOCITY METRES/MINUTE

11	2,6
10	2,4
9	2,1
8	1,8
7	1,6
6	1,3
5	1,1
4	0,8
3	0,5
2	0,2

OLD SET UP

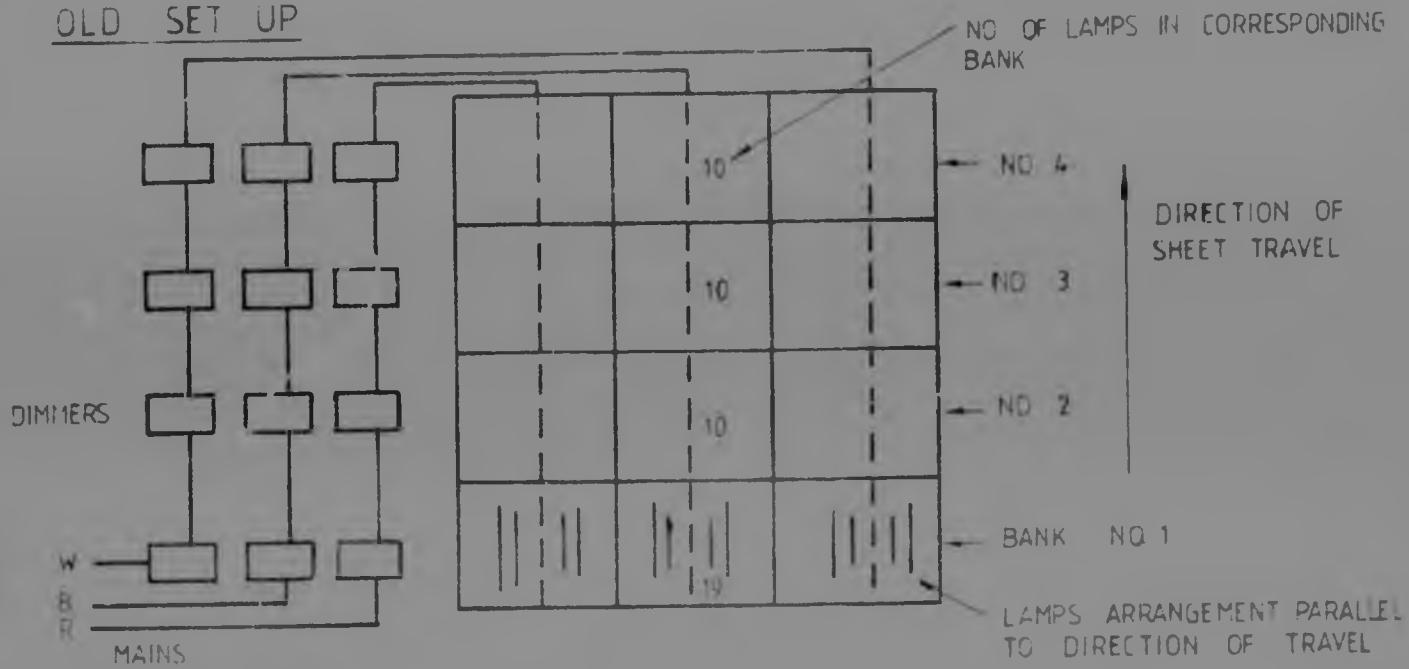

NEW SET UP

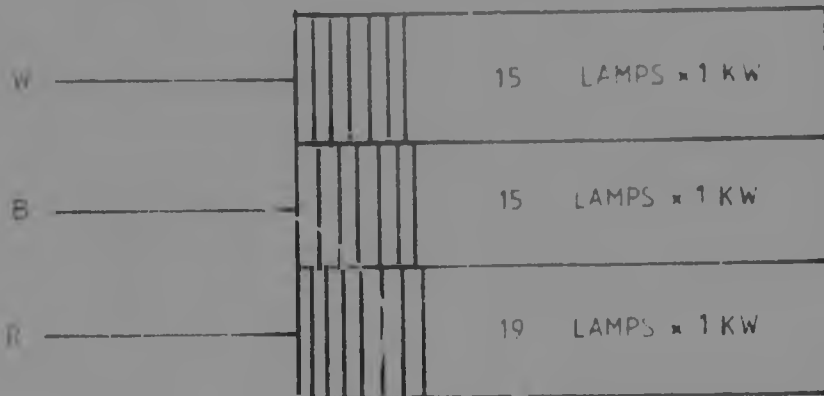
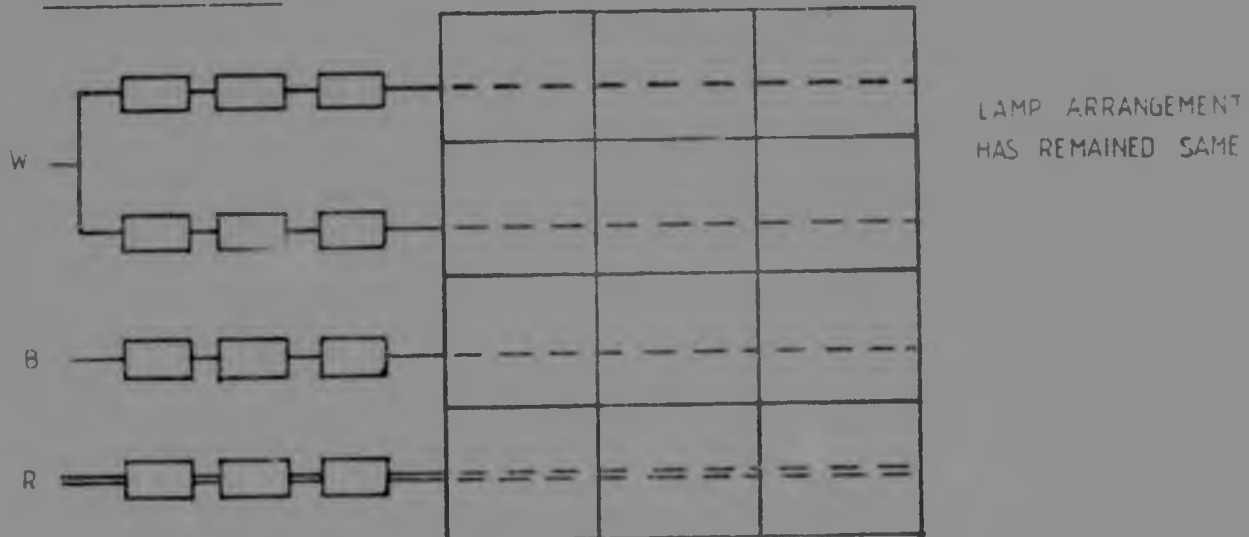

W = WHITE PHASE
 B = BLUE PHASE
 R = RED PHASE

TOTAL CAPACITY - AMPS AND KILOWATTS FOR INFRA HEATERS TO CONTROL
BANKS 1 to 4 AT TAPPINGS 4 to 10

BANK NO:1

Bank No:1 at Tapping No:4

	<u>Amps</u>	<u>kw</u>
Red Phase	10	2,2
White Phase	8	1,76
Blue Phase	8	1,76
<u>TOTAL</u>	<u>26</u>	<u>5,72</u>

Bank No:1 at Tapping No:5

	<u>Amps</u>	<u>kw</u>
Red Phase	11,5	2,53
White Phase	9	1,98
Blue Phase	9	1,98
<u>TOTAL</u>	<u>29,5</u>	<u>6,49</u>

Bank No:1 at Tapping No:6

	<u>Amps</u>	<u>kw</u>
Red Phase	12,5	2,75
White Phase	10	2,2
Blue Phase	10	2,2
<u>TOTAL</u>	<u>32,5</u>	<u>7,15</u>

Bank No:1 at Tapping No:7

	<u>Amps</u>	<u>kw</u>
Red Phase	14	3,08
White Phase	11	2,42
Blue Phase	11	2,42
<u>TOTAL</u>	<u>36</u>	<u>7,92</u>

TOTAL CAPACITY - AMPS AND KILOWATTS FOR INFRA HEATERS TO CONTROL
BANKS 1 to 4 AT TAPPINGS 4 to 10

BANK NO:1

Bank No:1 at Tapping No:4

	<u>Amps</u>	<u>kW</u>
Red Phase	10	2,2
White Phase	8	1,76
Blue Phase	8	1,76
<u>TOTAL</u>	<u>26</u>	<u>5,72</u>

Bank No:1 at Tapping No:5

	<u>Amps</u>	<u>kW</u>
Red Phase	11,5	2,53
White Phase	9	1,98
Blue Phase	9	1,98
<u>TOTAL</u>	<u>29,5</u>	<u>6,49</u>

Bank No:1 at Tapping No:6

	<u>Amps</u>	<u>kW</u>
Red Phase	12,5	2,75
White Phase	10	2,2
Blue Phase	10	2,2
<u>TOTAL</u>	<u>32,5</u>	<u>7,15</u>

Bank No:1 at Tapping No:7

	<u>Amps</u>	<u>kW</u>
Red Phase	14	3,08
White Phase	11	2,42
Blue Phase	11	2,42
<u>TOTAL</u>	<u>36</u>	<u>7,92</u>

Bank No:1 at Tapping No:8

	<u>Amps</u>	<u>kW</u>
Red Phase	14,5	3,19
White Phase	11,5	2,53
Blue Phase	11,5	2,53
<u>TOTAL</u>	<u>37,5</u>	<u>8,25</u>

Bank No:1 at Tapping No:9

	<u>Amps</u>	<u>kW</u>
Red Phase	15,8	3,48
White Phase	13	2,86
Blue Phase	13	2,86
<u>TOTAL</u>	<u>41,8</u>	<u>9,2</u>

Bank No:1 at Tapping No:10

	<u>Amps</u>	<u>kW</u>
Red Phase	16,5	3,63
White Phase	13,2	2,90
Blue Phase	13,2	2,90
<u>TOTAL</u>	<u>42,9</u>	<u>9,43</u>

BANK NO:1, 2 & 3 ARE THE SAME

BANK NO: 4

Bank No:4 at Tapping No:4

	<u>Amps</u>	<u>kW</u>
Red Phase	14,8	3,26
White Phase	17,5	3,85
Blue Phase	14,1	3,10
<u>TOTAL</u>	<u>46,4</u>	<u>10,21</u>

Bank No:4 at Tapping No:5

	<u>Amps</u>	<u>kW</u>
Red Phase	17,0	3,74
White Phase	19,8	4,36
Blue Phase	16,5	3,63
<u>TOTAL</u>	<u>53,3</u>	<u>11,73</u>

Bank No:4 at Tapping No:6

	<u>Amps</u>	<u>kW</u>
Red Phase	19,0	4,18
White Phase	21,8	4,80
Blue Phase	18,5	4,07
<u>TOTAL</u>	<u>59,2</u>	<u>13,05</u>

Bank No:4 at Tapping No:7

	<u>Amps</u>	<u>kW</u>
Red Phase	20,8	4,58
White Phase	20,5	4,51
Blue Phase	20,2	4,44
<u>TOTAL</u>	<u>61,5</u>	<u>13,53</u>

Bank No:4 at Tapping No:8

	<u>Amps</u>	<u>kW</u>
Red Phase	22,8	5,016
White Phase	25,5	5,610
Blue Phase	22,0	4,840
<u>TOTAL</u>	<u>70,3</u>	<u>15,466</u>

BANK NO: 4

Bank No:4 at Tapping No:4

	<u>Amps</u>	<u>kW</u>
Red Phase	14,8	3,26
White Phase	17,5	3,85
Blue Phase	14,1	3,10
<u>TOTAL</u>	<u>46,4</u>	<u>10,21</u>

Bank No:4 at Tapping No:5

	<u>Amps</u>	<u>kW</u>
Red Phase	17,0	3,74
White Phase	19,8	4,36
Blue Phase	16,5	3,63
<u>TOTAL</u>	<u>53,3</u>	<u>11,73</u>

Bank No:4 at Tapping No:6

	<u>Amps</u>	<u>kW</u>
Red Phase	19,0	4,18
White Phase	21,8	4,80
Blue Phase	18,5	4,07
<u>TOTAL</u>	<u>59,2</u>	<u>13,05</u>

Bank No: 4 at Tapping No:7

	<u>Amps</u>	<u>kW</u>
Red Phase	20,8	4,58
White Phase	20,5	4,51
Blue Phase	20,2	4,44
<u>TOTAL</u>	<u>61,5</u>	<u>13,53</u>

Bank No:4 at Tapping No:8

	<u>Amps</u>	<u>kW</u>
Red Phase	22,8	5,016
White Phase	25,5	5,610
Blue Phase	22,0	4,840
<u>TOTAL</u>	<u>70,3</u>	<u>15,466</u>

Bank No:4 at Tapping No:9

	<u>Amps</u>	<u>kW</u>
Red Phase	24,5	5,39
White Phase	27,5	6,05
Blue Phase	23,2	5,10
<u>TOTAL</u>	<u>75,2</u>	<u>16,54</u>

Bank No:4 at Tapping No:10

	<u>Amps</u>	<u>kW</u>
Red Phase	24,5	5,39
White Phase	27,8	6,12
Blue Phase	23,5	5,12
<u>TOTAL</u>	<u>75,8</u>	<u>16,68</u>

38.0 SURFACE FINISH CONSIDERATIONS

After establishing the desired characteristics of the coating, the difficult challenge remaining was to attain a good surface finish, eliminating what is known as orange peel.

One of the challenges was trying to define surface finish. We minimized the psychological factors involved by limiting or controlling human judgement bias as much as possible. No one factor controls the level of orange peel. Some of the variables that affect the level are:

- (a) Properties of the polymer
- (b) Filler content
- (c) Particle size of the powder
- (d) Cure characteristics and time-temp rate at which the coating is cured
- (e) Thickness of the coating
- (f) Application equipment to a small degree
- (g) Position of the coated panel during cure (degree of tilt from horizontal).

Each of these factors had to be studied, one at a time, while controlling all others.

One by one, an optimum number for each variable was established.

NOTE :

Numerous tests have been performed to establish the effects of various parameters on strength and appearance of cured powder coating films but only significant ones have been listed.

All of the standard operations referred to in chapter six have been performed on powder coated panels, to examine the performance and appearance of post formed components.

At present we have been using decorated unvarnished sheets of different product destination produced at our Vanderbijlpark plant and powder coated at our Wynberg Workshop.

Ideally what we are looking at for the future is as per Chapter 1 (a continuous operation.)

39.0 POWDER EVALUATIONS

Powder evaluation was carried out in a pilot operation set up in the MB laboratory at Wynberg. Many powders were sprayed, cured and the coatings evaluated. Most of the powders tested were clear epoxies and clear epoxy-polyesters because of their availability.

Powders from the same supplier were tested several times to check the reproducibility of their properties from batch to batch.

Reproducibility of colour, gloss and lack of orange peel were checked particularly closely. Other properties examined included: edge coverage, ability to withstand clamping and tooling, drilling from the underside and adherence of film.

The tests indicated that levelling of a powder coating is a function of particle size. The smaller the particles the better the flow and levelling.

As a result, the powder required for use should be ultrafine.

The powders ultimately selected give a 48 to 52 percent 60° photo-volt gloss. The powder must handle well in the application and overspray recovery equipment.

Some powders were found to have a tendency to clog. The powders initially selected were epoxies capable of meeting our rather difficult requirements. However, powder evaluation continues as more and better powders become available.

It was found that the thermosetting epoxy-polyester powder provided better colour retention and did not discolour when accidentally subjected to excessive heat during curing. Although the epoxy-polyester will cost more per Kg., its lower specific gravity means greater coverage per Kg., and its applied cost per square metre at equivalent thickness may be lower than that of the epoxy.

39.1 Mechanical Properties

One of the major advantages of epoxy powder coatings is their ability to develop films with mechanical properties far superior to those produced by most other organic coatings. Typical mechanical test results obtained with epoxy powder applied at a film thickness of 100 microns on 0,7mm cold rolled steel panels (AECI Laboratory Durban) are shown below.

<u>Test</u>	<u>Results</u>
Direct Impact	10 Joules
Reverse impact	10 Joules
Flexibility	No failure on conical mandril
Scratch hardness	4 000 grams

The mechanical performance of epoxy powder coatings is influenced to a large extent by film thickness and stoving schedule. (App. 12)

a) Film Thickness

As it has been clearly demonstrated that the protection against corrosion using epoxy powder coatings increases with increasing film thickness, it would appear logical to apply as thick a coating as possible. Unfortunately as the applied film thickness is increased a point is reached at which any further increase in film thickness will result in a drop off of the mechanical properties of the film.

The precise stage at which this drop off begins depends on the object being coated, the stoving schedule used and on the powder itself.

It can be demonstrated by applying epoxy powder at various thicknesses to similar panels and then after stoving all the panels at the same schedule, subjecting them to impact and flexibility tests. (AECI lab).

<u>Film Thickness</u>	<u>Impact</u>	<u>Flexibility</u>
50 - 60 microns	Direct - Pass Reverse - Pass	Pass 6,4mm mandril Pass 3,2mm mandril
60 - 75 microns	Direct - Pass Reverse - Pass	Pass 6,4mm mandril Pass 3,2mm mandril
145 -160 microns	Direct - Pass Reverse - Pass	Pass 6,4mm mandril Pass 3,2mm mandril
195 -200 microns	Direct-slight Cracking Reverse - Pass	Pass 6,4mm mandril Fail 3,2mm mandril

The above tests were performed on 0,7mm cold rolled steel panels, stoved for 10 minutes at 180°C.

On deciding therefore on the optimum film thickness to be used on any particular application, both the degree of corrosion protection and mechanical properties required must be taken into consideration.

b) Stoving Schedule

The stoving schedule used with an epoxy powder can be regarded as by far the most important factor in determining the performance of the coating. Unlike conventional stoving enamels which remain tacky and cheesy, if insufficiently stoved, epoxy powder coatings remain hard and brittle, exhibiting poor adhesion until fully cured.

The only satisfactory method of ensuring that the oven temperature time schedule is correct is to test the epoxy powder film for full cure. This is done by testing its mechanical properties.

BREAKDOWN - REASONS

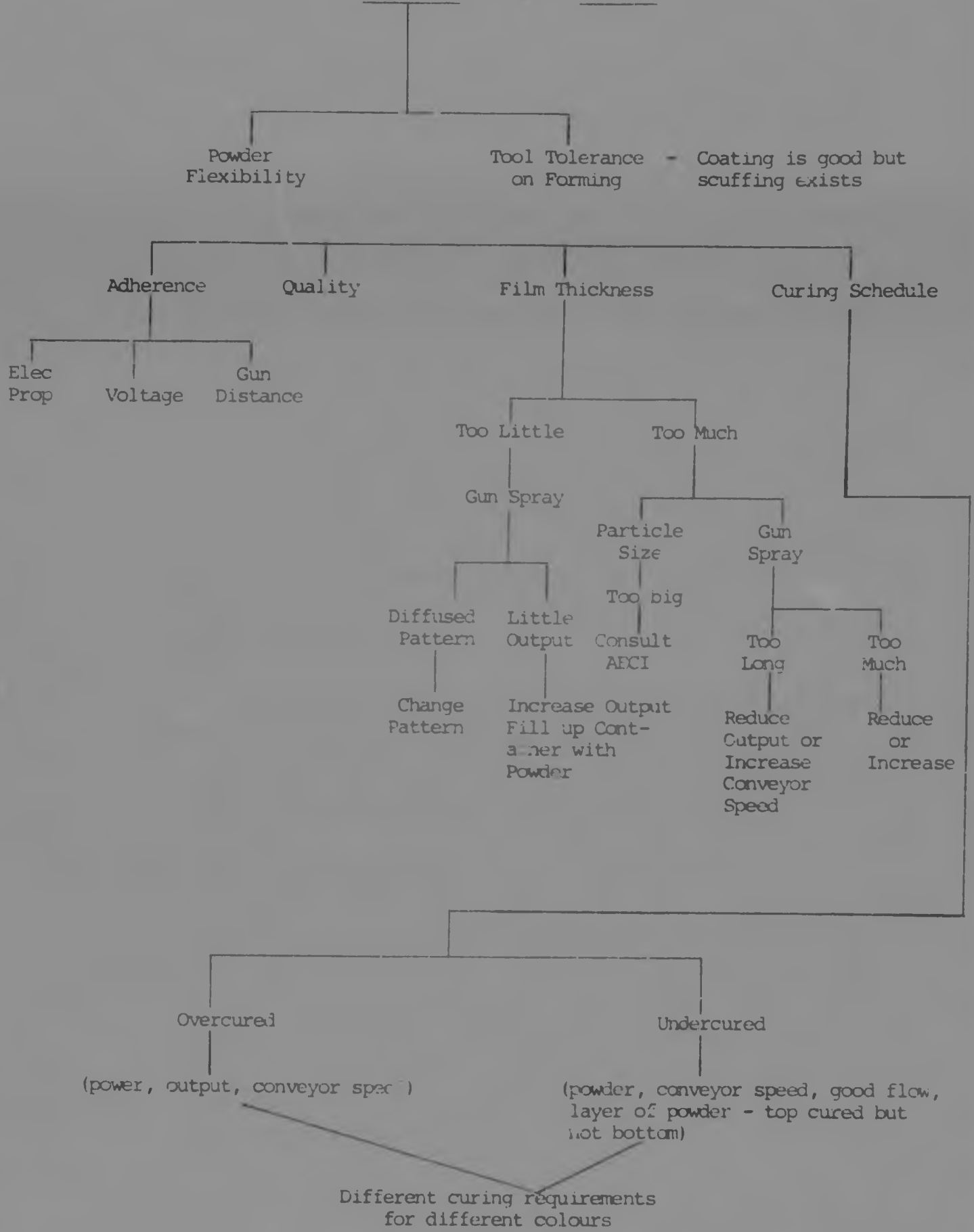

Impact and flexibility tests are used for this purpose, which give absolutely reliable and conclusive results.

Tests have shown that with a well formulated epoxy powder, there is virtually no fall off in the mechanical properties even with 100% overbake.

39.2 Reduction in Gloss by Blending Powders with Different Activities

When a fast curing epoxy resin based powder of high reactivity is mixed with a slower curing powder of low reactivity, and the resulting physical mixture is sprayed electrostatically and cured, two phases are in effect formed; these are a continuous phase attributable to the slower reacting material and a disperse phase of the faster reacting material. The reason for this is that the more reactive powder cures so rapidly that diffusion into the continuous phase is retarded and so the final cured film has a reduced gloss.

The greater the difference in reactivity between the two powders blended together the greater the reduction in gloss. This technique can be used for epoxy powder coatings with specular reflectances in the eggshell to semi gloss range.

39.3 Powder Coating Materials

At this point in time seven different powder coating materials have been tried and tested. To date we have limited our tests to two resin types, namely epoxy and polyester. Some beautiful acrylic finishes have been tested but in physical properties we have yet to find one that will match the epoxys and polyesters. They appear to be more brittle and fracture lines appear on bend testing and impact test.

While the powder vendors we have dealt with have taken steps to control their product quality closely, we have received material whose particle size differs largely.

40.0 EQUIPMENT EVALUATION

Almost every type of available electrostatic powder spray equipment was examined so that we could select that which best met our requirements effectively, efficiently and reliably.

Maximum transfer efficiency was of particular concern so as to minimise overspray. Although overspray can be reclaimed, excessive recycling through the recovery system tends to degrade the properties of the virgin powder. To determine transfer efficiency, parts were weighed before spraying, sprayed with powder holding application parameters constant, and weighed after coating.

The ability to apply a uniform film thickness was considered, with maximum uniformity sought. Of course, this is also a function of the powder being applied. Other factors examined were the ability to handle powder without clogging and the ease of cleaning and maintaining the gun and related equipment. Spray guns arrangements, conveyor designs and transporting patterns were evaluated.

Various types of curing ovens were examined and consideration was given to the parameters involved. As a result of this study we believe we selected the best equipment which is available for our specific application.

41.0 ULTRA-THIN POWDER COATING CAPABILITIES

41.1 Abstract

Clear epoxy powder coatings have been developed which can produce continuous 15 microns pinhole-free films using electrostatic spray applications.

The ability to produce ultra-thin coatings permits consideration of powder coatings for applications which were prohibited by the thicker coatings previously available.

The chemical resistance and mechanical integrity and appearance of these ultra-thin film coatings are equal or superior to that of the thicker coatings previously developed. Clear coatings permit greater latitude in post forming pre-coated metal.

41.2 Discussion

Clear epoxy and epoxy-polyester powder coatings have been developed which will produce continuous 15 microns pinhole-free films using electrostatic spray applications.

Pigmented epoxy coatings can be produced at the same thickness, however, hiding powder is not adequate except in the high optical density coatings such as black or deep-toned colours. Thin films with adequate hiding and high gloss can be produced in the 15-35 microns coating range.

The early powder coating markets were based upon thick coatings utilising fluidized bed and produced 200 microns or thicker coatings. Subsequently, the thin film markets developed in the range of 50-75 microns, using spray guns. The development of ultra-thin epoxy and epoxy-polyester powder coatings, to produce coatings which are pinhole-free in the range of 15-25 microns, is the development that is under discussion.

Up to this time, however, it has not been possible on a production basis to prepare these thin coatings.

Continuous pinhole-free coatings of 15-25 microns have been applied with clear materials. Pigmented coatings which would give corrosion resistance and hiding can be prepared in this range with a black pigment.

However, it is necessary to go up to 20-35 microns to get adequate hiding with materials other than black while maintaining the higher gloss.

The high hiding pigments will produce pinhole-free coatings with adequate hidings at this range.

The lighter colours with poorer hiding pigments usually require 30-45, or in some cases up to 50 microns to obtain adequate hiding.

We have developed coatings which are unique relative to their fine particle size, resin structure and modifying agents.

The coatings are laid down by means of an electrostatic spray to form a layer of powder and air which is comprised of an irregular temporary structure made up of powder particles resting on each other with air spaces in between the powder particles. As heat is applied there is an initial polymer deformation which due to the surface tension forms spherical particles and consequently causes the small particles to decrease forming larger void areas.

These larger voids tend to expand rapidly as the polymer particles tend to flow out and rise to the surface, leaving the material as a continuous film. It is necessary to control the rate of curing and the rate of flow to permit the air to leave the film and to give us a void free film. By control of the variable mentioned this is possible.

The mathematics relative to the formation of thin films has been studied in detail by W.M. Rodgers of the Goodyear Tire and Rubber Company and C.C. Furmas, formerly of the Cornell Aeronautical Research Laboratory.

They have shown that initial void content can range up to 60% and only with an extremely wide range of particles are the number of voids limited.

The flow out of the particles in order to obtain a 15 microns coating necessitates the particle sizes to be in the range of 18-20 microns. When this size is available, then it is possible to control the thickness by building up multiple layers one upon the other. By maintaining the proper flow additive these can be fused into a continuous void free film.

The question of the performance of these ultra-thin coatings has been answered by a series of laboratory and end-use testing.

A summary of the types of tests performed is given in (Appendices 6 and 12).

The adhesion as tested by cross hatch is excellent. Shear and tension values have been determined. The abrasion resistance far exceeds that of most commercial cross-linked coatings. The impact resistance exceeds 20 in Newtons both direct and reverse. Pencil hardness is greater than 5H. The continuity of film is checked using a pinhole tester.

Formability has been shown to be excellent by the mandrel bend test.

Corrosion resistance has been excellent as has been solvent resistance to common chemicals, such as bases, acids and chlorinated solvents. The gloss can vary depending upon the composition.

It is necessary to maintain the powder dry, since moisture will tend to cause agglomeration and increase the thickness as well as causing poor spraying and possible pinholing. The small particles accentuate the problem. The powder should be stored below 25°C to prevent premature curing and loss of flow out during the curing operation. Normal safety precautions used in powder handling as with wheat, flour, cement must be practised.

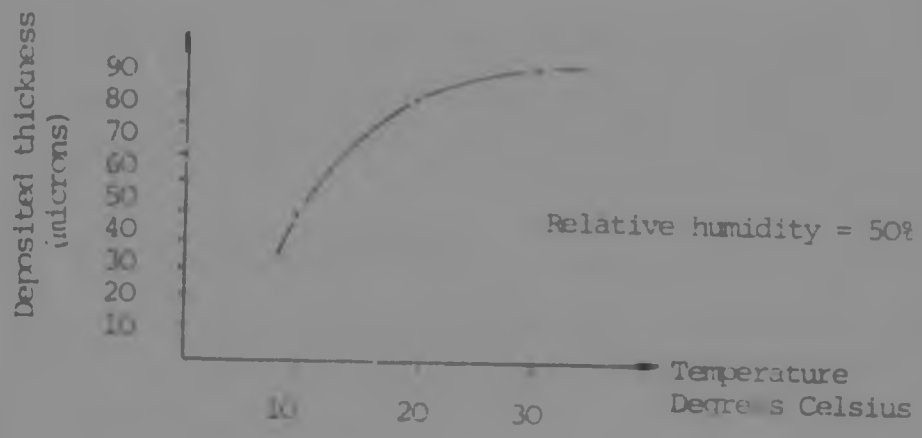

Figure 24

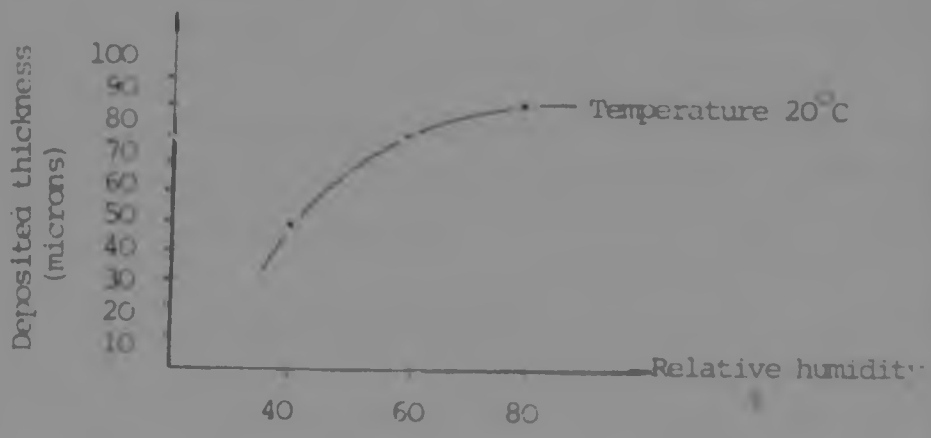

Figure 25

42. Transportation of Sheets

Initially various proposals were explored and discussed on the subject of possible handling mechanisms for the transportation of sheets such as :

1. Hanging vertically
2. Vertically transported by exercising pressure on the sheets trim area.
3. Horizontally transported on belt conveyor

After a thorough evaluation of each, more emphasis was placed on the last of the abovementioned modes of transportation. The final configuration is shown on page as per photo.

42.1 Vertical Hanging

This involves the piercing in two points of the sheets and their manual hanging on hooks supported by an overhead conveyor.

Although this method did not deviate from existing standard procedures in powder coating applications, it was felt that the two extra operations of piercing and hanging were undesirable. A simpler and if possible automatic process had been envisaged from the conception of the project.

42.2 Gripper Edge Pressure

The handling of the sheets by exercising pressure on their perimeter trim area was technically and financially checked. From a technical point of view, it was rather critical because of the variation in size and the limitation in magnitude of the trim area by which the process would be governed.

We then had to consider the enlargement of the sheet in one direction only, in order to have a larger working and gripping area. This alternative did not affect the price of the raw material significantly but the idea was left aside on the grounds of being laborious to construct and expensive to install. In the writer's opinion, it is still very valid and worth looking at in final design stages.

42.3 Horizontal Conveyor

Handling the sheets on the flat, resting on conveyor belts of suitable nature seemed the best solution at least for the time being with some restriction though as to the curing process selected, which had to be in suit of our conveying mechanism. This mode of processing the sheets on the flat led us to choose an infrared oven which would straddle over the belt conveyor and cure our product as a sequential step to powder coating it. This configuration gave us the opportunity to have a continuous process of variable speed for the coating and curing cycle and adjustable over workpiece distance.

Placement of Sheets

During the experimenting period, the sheets would be manually loaded and unloaded. At a later stage we would consider automatic loading and unloading, probably by using pneumatic arms to collect the sheets from a stacking support and place them on the belt synchronically.

43. Anticorrosion and Chemical Resistance

In the difficult field of anti corrosion, adhesion is playing an important role, one should say the most determining. Powders are not carried by a solvent which helps normally for the peaks and valleys. Lack of adhesion is the main disadvantage of powder coatings, which makes its utilisation on smooth substrates very delicate in particular cases.

Of course we are speaking here about the intrinsic adhesion of cured thermosetting powders. Surface preparation by chemical conversion, or the use of primers prior to powder application enhance the high performance of thermoset powders.

These comments are not pessimistic but we must admit that the solution of the adhesion problem in powder coatings would help to solve a lot of problems we have encountered and answer questions we will be confronted with in the near future when the research schedules will be directed to more sophisticated developments.

44. Forming and Drawing of Tinplate

Over the years, the main research and development in press forming, have taken three directions.

1. Tests to determine properties of material which will indicate their press performance.
2. Improve materials available, provide greater uniformity within each grade and develop grades for specific types of pressing.
3. Improve processes including toolmaking and setting, improving presses and press control and increasing knowledge of lubrication.

During pressing, tinplate is subjected to a series of complex deformation which include stretching, drawing bending and unbending and seldom is any one deformation mode operating alone.

However, whatever the deformation mode or the pressing method used, there are criteria for distinguishing success or failure of a pressing.

Success Requires :

1. Absence of metal fracture (failure).
2. Absence of visible necking.
3. Satisfactory forming to shape and retaining shape without undue springback.
4. Satisfactory surface after pressing. If the component is exposed to view in service it would require freedom from stretcher strains and orange peel effects.
5. Freedom from wrinkling.
6. Freedom from undue earing.

When a pressing fractures during forming the tear is the visual indication that the metal has been worked beyond its prevailing formability limit and to make the part without failure what is needed is either :

1. A more formable metal or possible increased thickness (supply expense).
2. Different lubrication (supply and production expense).
3. Modified tooling to alter the strains imposed (production expense).

In many practical cases, however, the sheet metal does not tear, although some points on the pressing are close to failure and many components are rejected for visible thinning or 'necking' where the strain has been greatest.

Whether or not a particular sheet of metal can be formed into a specific part without breakage depends on :

1. Material properties
2. The surface conditions
3. The blank size and shape
4. Lubrication
5. Press speed to blank holder pressure
6. Punch and die design
7. Possibly a number of other factors which are not yet fully understood.

These are the parameters that are presently under close examination.

In order to determine their relative contribution to the failure modes observed, other than the ones originating from the properties of the powder coating itself, one would have to get involved into a different area altogether. At this point in time it has been decided to only make tentative tooling modifications on equipment available at our development workshop, to try and alleviate any problems encountered. Nevertheless some points which are thought to bear significant importance are :

The amount and type of deformation determines when a sheet will fail on pressing and therefore the practical operator is interested in the properties of the material which :

1. Determine the amount of deformation it can withstand
2. Determine the geometry and metal flow of the pressing which determine the amount and type of deformation that will be required.

In technical departments concern is partly with testing procedures to determine as well as possible the properties of the metal when subject to complex deformation process and partly with determining the state of complexity of the total deformation required in the commercial operation.

44.1 Forming Mode

Forming operations can be considered as being made up from various proportions of stretching and deep drawing on the basis that blanks are transformed through the stretching and drawing action of the dies to the required shapes. Stretch forming and deep drawing in their ideal form can be separately identified.

44.2 Ideal Stretching

A blank is held tightly around the edge between the dies such that there is no movement over the die rings. As the punch descends, deformation occurs only in the area of the blank over the die openings. Thinning occurs only in the deformed area under the punch nose.

44.3 Ideal Drawing

In this case the blank holder pressure is less and will allow controlled movement of the blank into the die as the punch descends.

Deformation occurs mostly in the outer position of the blank with only a little over the punch head. In this case the punch load increases rapidly to a maximum value before very much punch travel and drawing begins at maximum load with the load decreasing steadily to zero when draw through occurs.

The deformation pattern of a pressing can be readily determined by the use of circular grid patterns imprinted on the component before test. During deformation the circle is deformed to a larger circle or an ellipse and the regions of greatest deformation as percent engineering strain, can be determined from measurements of the major and minor axes of the ellipses e_1 and e_2 respectively. When the material is subjected to stretching, both major and minor axes will be greater than the initial circle diameter, that is, there are tension-tension strains in the surface plane.

On the other hand, when drawing has occurred the major axis will be greater but the minor axis will be less than the original circle diameter, that is there are tension compression strains in the sheet plane.

From measurement of the ellipse axes, it is possible to determine quickly the amount of deformation both in relation to the direction of principle strain e_1 , that is the strain parallel to the major axis and in relation to the minor strain, e_2 or that parallel to the minor axis.

From a large number of laboratory and production experiments initially introduced by Keeler and Goodwin and where the major and minor strains at different points on a pressing have been measured, particularly up to the point of failure, it has been found that, when these are plotted on a graph with major strains as ordinate and minor strains as abscissa, the rupture points form a locus which separates failure areas from safe areas.

This information becomes the basis of a forming limit diagram (FLD).

44.4 Wrinkling

Strain limits for local necking and fracture have been discussed and the tool setter has certain rules which allow him to modify conditions to reduce critical strain severity. One common control factor is blank holder pressure, the reduction of which may allow more flange material to flow into the part.

However, if the blank holder pressure is reduced too greatly a new defect, wrinkling, may appear. Wrinkles may occur in flange areas due to the high compressive stresses or they may occur in unsupported stretched areas where a die cavity is considerably greater than the drawing punch.

44.5 Lubrication

The effects of lubricants have a number of points which must be considered.

1. ease of application and film forming properties
2. ease of removal
3. corrosion protection
4. lubricating properties at the working strain rates

The type of lubricant, the punch speed and the blank holding load all affect the frictional forces that are generated between the material and the tooling. Friction forces in the blank holder region increase the radial force required to draw the blank to the smaller diameter.

Friction around the drawing die radius causes a tension loss between that existing in the cup wall and that transmitted to the flange in a manner similar to that observed when a belt is pulled over a fixed pulley.

Therefore, the die radius friction acts as a multiplying factor increasing the force required to deform the flange.

45. Gel Time Procedures

A small quantity of powder is placed on the hot cure surface and the stop watch is started. Specimen volume is about equivalent to that of a medium sized pea. The melted powder is gently stirred until it begins to solidify. Stop-watch is stopped. The gel time is the time elapsed from the instant the powder touches the cure plate surface until it begins to solidify. An average of five determinations is recorded as the gel time, to the nearest second. Cure plate was fitted with self adhesive temperature tape. Cure plate surface is maintained at such a temperature, so that no tin flow or discolouration is evident.

46. Appearance of Cured Films

The phenomenon of flow has been carefully considered. In powder technology, melt viscosity, reactivity and special flow promoters are the tools to obtain good flow, whilst manageable curing schedules are being maintained. As can be expected the flow of a powder coating becomes poorer as the speed of cure increases, or more correctly, the faster the initial gelation of the powder. The proper balance between flow and reactivity had to be established for the application considered. The use of lower melting point resins is another way of increasing the flow, although blocking of the powder on storage can result. Extensive development work carried out during the last four years by raw material suppliers and powder manufacturers has resulted in the production of special additives which improve the flow properties of the ultimate powder coating system.

47. Ultra Thin Powder Coatings

Clear powder coatings have been developed during this Research period, which will produce continuous 30 microns pinhole - free films using electrostatic spray. They have been tested by being dipped into a solution of copper sulphate which corrodes tin coating when latter is exposed.

Thin films can be produced in the 18 - 32 microns range. This ability to produce ultra thin coatings permits consideration of powder coatings for applications which were prohibited by the thicker coatings.

The chemical resistance, electrical and mechanical integrity and appearance of these ultra thin film coatings are equal and superior to that of the thicker coatings (50 microns) previously developed.

It has been found that clear coatings permit greater latitude in post forming precoated metal.

47. Ultra Thin Powder Coatings

Clear powder coatings have been developed during this Research period, which will produce continuous 30 microns pinhole - free films using electrostatic spray. They have been tested by being dipped into a solution of copper sulphate which corrodes tin coating when latter is exposed.

Thin films can be produced in the 18 - 32 microns range. This ability to produce ultra thin coatings permits consideration of powder coatings for applications which were prohibited by the thicker coatings.

The chemical resistance, electrical and mechanical integrity and appearance of these ultra thin film coatings are equal and superior to that of the thicker coatings (50 microns) previously developed.

It has been found that clear coatings permit greater latitude in post forming precoated metal.

48. The Importance of Opacity in Thin Film Coatings

It has been seen that the time cost of a finish goes well beyond the cost/kg of powder. The specific gravity of the coating material must be taken into account and can have quite an effect on the cost.

Thus the following theoretical coverage is obtainable for coatings of various specific gravities.

TABLE 13

Theoretical coverage of coating material at various Sp. Gr.
(Dry Film basis) (App. 3)

<u>Specific Gravity</u>	<u>Coverage - m²/Kg/25 microns</u>
1,0	40
1,1	36,4
1,2	33,3
1,3	30,8
1,4	28,6
1,5	26,7
1,6	25,0
1,7	23,5
1,8	22,2
1,9	21,0
2,0	20,0

Similarly for various film thicknesses of 20,30,35,40,45,50 microns the following tables are constructed.

Thickness	Specific Gravity										
	1,0	1,1	1,2	1,3	1,4	1,5	1,6	1,7	1,8	1,9	2,0
20 microns	Coverage										
	50	45,5	41,7	38,5	35,7	33,3	31,3	29,4	27,8	26,3	25

	1,0	1,1	1,2	1,3	1,4	1,5	1,6	1,6	1,8	1,9	2,0
30 microns											
	33,3	30,3	27,8	25,7	23,8	22,2	20,8	19,6	18,5	17,5	16,7

	1,0	1,1	1,2	1,3	1,4	1,5	1,6	1,7	1,8	1,9	2,0
35 microns											
	28,6	26,0	23,8	22,0	20,4	19,0	17,8	16,8	15,9	15,0	14,3

	1,0	1,1	1,2	1,3	1,4	1,5	1,6	1,7	1,8	1,9	2,0
40 microns											
	25	22,7	20,8	19,2	17,8	16,7	15,6	14,7	13,9	13,2	12,5

	1,0	1,1	1,2	1,3	1,4	1,5	1,6	1,7	1,8	1,9	2,0
45 microns											
	22,2	20,2	18,5	17,0	15,9	14,8	13,9	13,0	12,3	11,7	11,1

	1,0	1,1	1,2	1,3	1,4	1,5	1,6	1,7	1,8	1,9	2,0
50 microns											
	20	18,2	16,7	15,4	14,3	13,3	12,5	11,8	11,1	10,5	10

Figure 26 gives a general relationship between specific gravity of the coating, film thickness and coverage in the 20 - 50 microns thickness range. Using a straightedge, the specific gravity of the coating is located in the left hand scale and caused to intersect with the appropriate film thickness on the center scale at the same specific gravity. The average is read on the right hand scale.

As an example three lines are drawn showing the coverage of

- a) 20 microns film of a coating with specific gravity of 2,0.
- b) 30 microns film with a specific gravity of 1,5
- c) 20 microns film with a coating of a specific gravity 1,4.

From this point, two other factors are taken into consideration:

1. The transfer efficiency which is the amount of material sprayed toward the part compared to the amount actually applied to the part. Transfer efficiency varies depending on the configuration of the article being coated ranging from a high of about 90% for flat sheets to about 50% for various configurations.

In the case of electrostatic powder spray it is possible to approach 100% total efficiency if all powder is reclaimed and recycled. A figure of 95% is used here in cost calculations for electrostatic powders, which degree is realised because of only one colour application.

2. The material cost calculation can stop at this point that is

$$\text{Cost Rand/m}^2 / 25 \text{ microns} = \frac{\text{Cost/Kg}}$$

$$\text{Coverage m}^2/\text{kg} \times \text{application effic.}$$

FIGURE 26

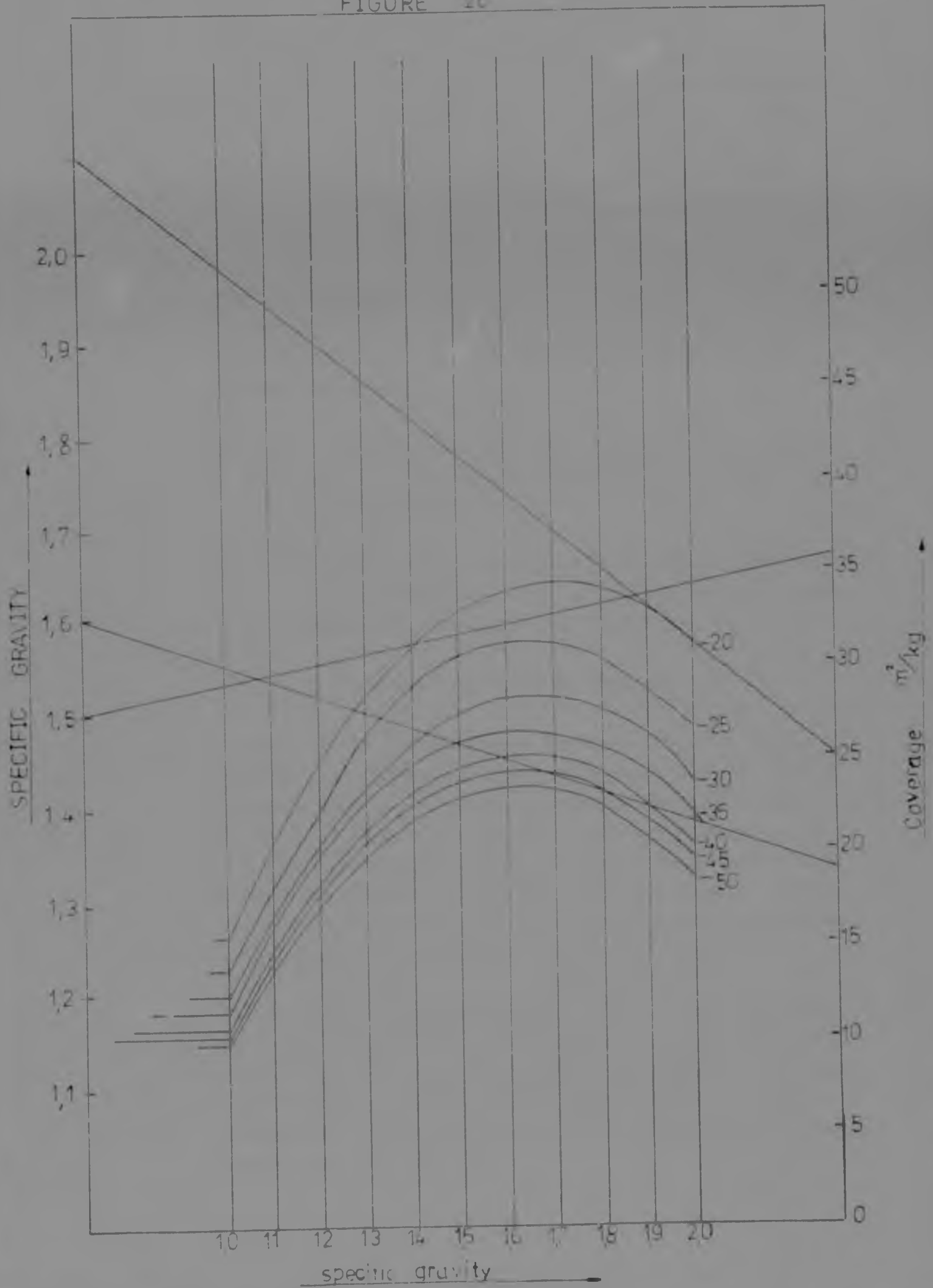

However, the fact is that until now, powders are generally applied at 50 microns or greater thickness, but in our case the practical application of nominal 25 microns films by electrostatic powder spray techniques is imminent and fractional of 25 microns coatings are in the writer's opinion less than one year away.

48.1. Coating Procedure

In the M.B. application of powder coating materials we had various options open to us.

1. To powder coat unvarnished flat sheets before tooling, with clear thermosetting powders so as to protect the printed design.
2. To powder coat the underside of the sheet either by a clear thermosetting powder or by a colour resin powder which would match the overall appearance.
3. To powder coat the finished components.

Option three presented numerous problems due to the variety of the existing products and consequently due to the difficulty one would have in handling and powder coating the different products. Since therefore most of our products were round built up, containers and were consequently almost impossible to powder coat in the finished stage we opted to develop a system which would withstand the metal deformation normally encountered in canmaking.

The decision had to be made whether we would powder coat both sides of the sheet at the same time using a clear powder, or powder coat the printed side with a clear powder first and then the underside with a colour based resin. This could only be decided once the effect of hiding power on cost and the coating implications were examined.

Coating difficulties would prevail in the sense that one would not like the spraying of the one powder to influence the application and register area of the other, due to 'wrap around' adhesion properties of powder and if solved this problem how reliable and consistent would the solution be on a full production basis.

48.2 Effect of Hiding Power on Cost

The hiding power of a coating is that property which enables it to obliterate beyond recognition any background over which it may be spread. At film thicknesses of 50 - 75 microns or greater, the hiding power of the coating is generally of little consequence. At low film thicknesses of about 25 microns or less the nature of the substrate can affect the appearance of the film. If the film does not have sufficient hiding power, it appears 'splotchy' or to vary in colour.

One way to correct the problem is to increase the thickness until the coating appears uniform. This will, of course, result in a higher material cost. Another method is to increase the hiding power of the coating by increasing the amount of opacifying pigments, decreasing the brightness or both. Increasing the quantity of opacifying pigment results in an increase in specific gravity and a decrease in coverage. Therefore a quantitative method is required for calculating the true cost of the coating material as a function of the hiding power.

48.3 Measuring Hiding Power

A detailed method for determining hiding power is given subsequently to this section. This method, a modification of procedures generally established in the paint industry, is based on a measurement of contrast ratio and the scattering co-efficient S of the coating. The scattering co-efficient is dependent on the quantity, type, particle size, and degree of dispersion of the pigments.

It can be determined from the contrast ratio using the mathematical relationship developed by Kubelka and Munk. Contrast ratio can be considered as the ratio of the light reflected by the coating over a black substrate (R_b) to the light reflected by the coating over a white substrate (R_w). At complete hiding $R_b = R_w$ and the contrast ratio is unity.

To determine contrast ratio, the test coating is applied over a white substrate and a black substrate at the intended end use thickness. The reflectance of the coating over each of the substrates is measured using a calorimeter vs a barium sulphate or magnesium oxide control. Coating thickness is determined from the weight of the coating and its specific gravity rather than by direct measurement since the weight method is more accurate and the contrast ratio is sensitive to film thickness.

Using the contrast ratio determined and the value obtained for R_b , the scattering co-efficient S is found using the graph in figure by locating the scattering power SX and dividing by the film thickness.

48.4 Experimental

Two powders were prepared by AECI at different levels of opacity.

Powder 'A' is similar to many powders currently being sold commercially. Powder 'B' was a high opacity material. Using the procedures described, the contrast ratio and coverage for each coating was determined and the data summarised in Table. After reviewing the data it was found that the high opacity material, powder 'B' gives the same degree of opacity at approximately a 20% lower film thickness but the specific gravity is higher and the coverage only slightly better. There is though, a much higher reflectance (90, 25% vs 83,3) and scattering co-efficient (4,21 vs 2,76) of powder 'B'.

This means that the higher opacity material can be applied at a lower thickness and still give the same appearance as the standard material.

The significance of these data are summarised in Table 16. If powder 'A' and powder 'B' are compared only on the basis of specific gravity and coverage, powder 'B' is about 12,5% more expensive to use than powder 'A', all other things being equal. When compared on the ability to hide the substrate, powder 'B' is 36% lower in cost on a use basis.

48.5 Theory

The following definitions are in order :-

- | | | |
|----------------|---|------------------------------------------------------------------------------------------------------------------------------------|
| Coating System | : | The combination of a coating material applied to a substrate. |
| Hiding Power | : | The ability of a coating system to obliterate beyond recognition any background over which it is applied. |
| Reflectance | : | The ratio of light diffused by a coating system to the light diffused by a near perfect diffuse reflector such as magnesium oxide. |
| Scattering | : | The cumulative effect of reflection, diffraction and refraction from a coating system on the incident light. |
| Absorbance | : | That part of incident light not scattered by a coating system. |
| Coverage | : | The area which can be hidden by a coating system at a specified contrast ratio per unit weight or volume of coating material. |

The ratio of light absorbed to light scattered K/S is dependent upon the specific pigments and their concentration in the medium. Scattering efficiency of a pigment can be measured according to the well known Kubelka - Monk equations :-

$$\frac{K}{S} = \frac{(1 - R_{\infty})^2}{2 R_{\infty}} \quad - (3)$$

$$S = \frac{2,303}{d} \cdot \frac{R_{\infty}}{1 - R_{\infty}^2} \cdot \log \frac{R_{\infty} (1 - R_0 R_{\infty})}{R_{\infty} - R_0} \quad - (4)$$

where R_{∞} = diffuse reflectance for the coating system at infinite thickness such that a further increase in thickness does not appreciably affect the K/S ratio.

R_0 = diffuse reflectance for the coating system over a black substrate of which reflectance $\rightarrow 0$

d = film thickness

Consequently, a method is needed to measure diffuse reflectance, R and the scattering co-efficient S . Diffuse reflectance can be easily measured with any number of colourimeters or spectrophotometers. To determine the scattering co-efficient, S the coating is applied over a white substrate (reflectance about 80%) at sufficient thickness to hide the substrate and over a black substrate ($R \rightarrow 0$) at the normal thickness range. The reflectance is measured for each versus a near white diffuse reflector. The ratio of reflectance over black (R_b) to reflectance over white (R_w) is known as the contrast ratio. It should be noted that R_w is approximately equal to R_{∞} and R_b is approximately equal to R_0 . Using graphs derived from equation 4 and the measured contrast ratio, the scattering co-efficient, S can be determined.

48.6 Procedure

In order to determine the contrast ratio and subsequently the scattering co-efficient two types of substrate are required.

The ratio of light absorbed to light scattered K/S is dependent upon the specific pigments and their concentration in the medium. Scattering efficiency of a pigment can be measured according to the well known Kubelka - Monk equations :-

$$\frac{K}{S} = \frac{(1 - R_{\infty})^2}{2 R_{\infty}} \quad - (3)$$

$$S = \frac{2,303}{d} \cdot \frac{R_{\infty}}{1 - R_{\infty}^2} \cdot \log \frac{R_{\infty} (1 - R_0 R_{\infty})}{R_{\infty} - R_0} \quad - (4)$$

where R_{∞} = diffuse reflectance for the coating system at infinite thickness such that a further increase in thickness does not appreciably affect the K/S ratio.

R_0 = diffuse reflectance for the coating system over a black substrate of which reflectance $\rightarrow 0$

d = film thickness

Consequently, a method is needed to measure diffuse reflectance, R and the scattering co-efficient S . Diffuse reflectance can be easily measured with any number of colourimeters or spectrophotometers. To determine the scattering co-efficient, S the coating is applied over a white substrate (reflectance about 80%) at sufficient thickness to hide the substrate and over a black substrate ($R \rightarrow 0$) at the normal thickness range. The reflectance is measured for each versus a near white diffuse reflector. The ratio of reflectance over black (R_b) to reflectance over white (R_w) is known as the contrast ratio. It should be noted that R_w is approximately equal to R_{∞} and R_b is approximately equal to R_0 . Using graphs derived from equation 4 and the measured contrast ratio, the scattering co-efficient, S can be determined.

48.6 Procedure

In order to determine the contrast ratio and subsequently the scattering co-efficient two types of substrate are required.

White - flat white gloss plate which is opaque and reflects 80% of a light striking the surface can be used.

Black - conventional paint test panels coating with a flat black lacquer (R → O) can be used.

For each coating system to be analysed one white panel and three black panels are required. After the panels have been prepared they are weighed to the nearest milligram and the weights recorded. The powder coating is then applied keeping the back of the panel covered to allow powder deposition only on the front of the panel.

White Panel

Spray one panel to a depth of 100 microns or greater keeping the coating as uniform as possible. Fuse the coating long enough to achieve full fusion and flow of the film. After cooling to room temperature, the panel is re-weighed and the coating weight determined.

Black Lacquered Panel

The three panels are carefully sprayed so that the thickness of the electrostatically applied coating when fused is in the normal range of 20 - 50 microns. Powder deposition on the back side of the panels must again be avoided. The coated panel is placed in the oven and the powder is fused to the finished film. The panels are carefully reweighed and the coating weight determined.

The coating thickness can then be determined based on the weight and specific gravity of the film.

$$X \text{ microns} = \frac{10^4 \times \text{film weight}}{\text{surface area} \times \text{specific gravity}} \quad - (5)$$

KUBELKA-MUNK OPACITY CHART

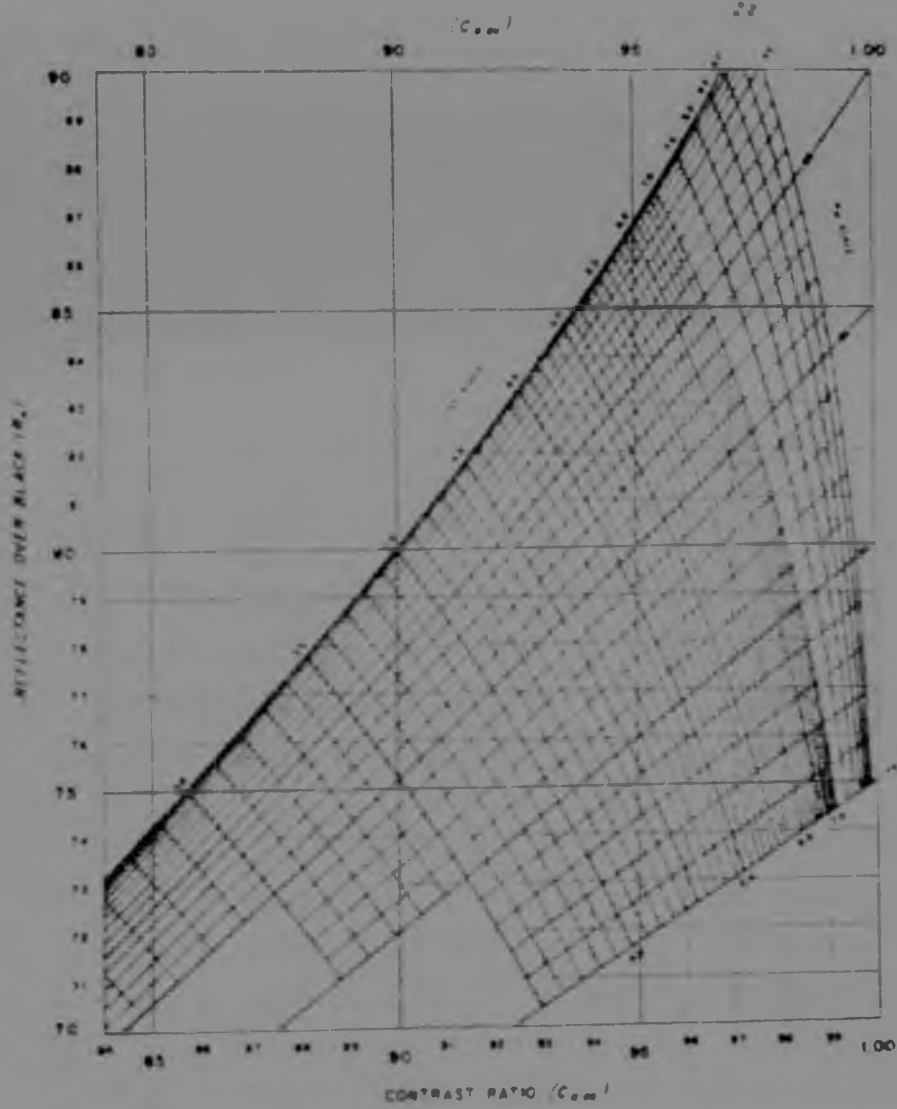

Figure 27

The reflectance is measured and recorded for each of four specimens versus barium sulphate or magnesium oxide using the Y tristimulus filter of a colourimeter. The contrast ratio (CR) is then calculated for each black panel using the following equations:-

$$CR = \frac{R_o}{R_{oo}} = \frac{R_B}{R_W} \quad - (6)$$

After the contrast ratios for each black panel have been calculated, their respective scattering co-efficients can be determined. These can be calculated using equation (4) or, more easily, determined through the use of the same equations in the form of a graph (See figure 27) Scales provided in Figure 27 include :

- | | | | |
|----|------------------------|---|-----------------------------------|
| 1. | Reflectance over black | - | R _B or R _o |
| 2. | Contrast ratio | - | CR |
| 3. | Reflectance over white | - | R _w or R _{oo} |
| 4. | Scattering Power | - | SX |

Any co-ordinates can be used for determining the scattering power, SX but R_o and CR will be used here. Whatever values are used to determine SX, whether R_o and CR, R_o and R_{oo}, or CR and R_{oo} the same should be used for all determinations. Small differences arise due to nonideal coating surface characteristics which can introduce an error if the same procedure is not followed in all cases.

Determination of the SX value is made by locating the horizontal line representing R_o on Figure 27 and the intersection of that line with the calculated C.R. that point is interpolated using the near vertical SX lines and recorded for each black panel. After the scattering power, S_i has been determined the scattering co-efficient is easily determined as follows :

$$S = \frac{SX}{X} \quad - (7)$$

From the values of R_{00} or R_w and S , the expected coverage can be calculated for specified contrast ratios. Complete hiding of the substrate is at $CR = 0,98$. Previous publications (2,7) provide equations relating to hiding ability as a function of R_{00} or R_w .

White panel area	=	5 100mm ²
Black panel No. 1 area	=	5 800mm ²
Black panel No. 2 area	=	5 800mm ²
Black panel No. 3 area	=	5 800mm ²

TABLE 14

	White Panel 72 x 72mm	Black Panel (4) 76 x 76mm	Black Panel (2) 76 x 76mm	Black Panel (3) 76 x 76mm
Initial weight	40,0980	10,4146	10,5160	10,318
Weight and Coating	<u>41,3855</u>	<u>10,9395</u>	<u>11,0822</u>	<u>10,875</u>
Coating weight	1,2875	0,5253	0,5662	0,5057
R _b (Colorimeter)		80,9	80,9	81
R _w (Colorimeter)	83,4			
CR (R _b /R _w)		0,970	0,970	0,971
X (microns) calculation below	7,107	2,565	2,774	2,478
SX (From figure 27)		6,3	6,30	6,39
S (SX/X)		2,456	2,271	2,579

Average S = 2,435

Calculations for film thickness :

Sp. Gravity = 1,383

$$X \text{ (microns)} = \frac{10^6 \text{ (film WT in Grams)}}{\text{(Area) (Sp. gravity)}}$$

$$X \text{ (Black 1)} = (124,65) (0,5253) = 65,48 \text{ microns}$$

$$X \text{ (Black 2)} = (124,65) (0,5662) = 70,58 \text{ microns}$$

$$X \text{ (Black 3)} = (124,65) (0,5057) = 63,04 \text{ microns}$$

$$X \text{ (White glass)} = (144,59) (1,2875) = 186,16 \text{ microns}$$

Surface area = 5 800 mm² for black panels
Surface area = 5 000 mm² for white glass

Using the values from the preceding

$$\begin{aligned} R_w &= 83,4 \\ S_{av} &= 2,43 \\ \text{Sp.Gr} &= 1,383 \end{aligned}$$

$$S = \frac{SX}{X} = \frac{6,3}{2,6} = 2,43$$

The average characteristics are then determined using Figure 28 for C.R. = 0,98.

Coverage rate in square meters per kilogram = 9,5. Film Thickness to coverage rate is 74,95 microns.

If no consideration is given to scattering as is frequently the case in the powder coating trade as it is today, the coverage for this material based solely on specific gravity would be quoted as 28 m²/Kg at 25 microns thickness.

$$\left(x \text{ microns} \frac{4893}{\text{sp. Gr. (Coverage in m}^2\text{Kg)}} \right) - (8) \text{ref } \dots$$

FILM THICKNESS TO COVERAGE

AT CONTRAST RATIO = 0.98

Coverage M ² / Kg	Film Thickness Microns
6,1	163,1
7,1	139,8
8,1	122,3
9,1	108,7
10,1	97,9
11,1	89,0
12,1	81,6
13,1	75,3
14,1	69,9
15,1	65,2
16,2	61,2
17,2	57,6
18,2	54,4
19,2	51,5
20,2	49,9

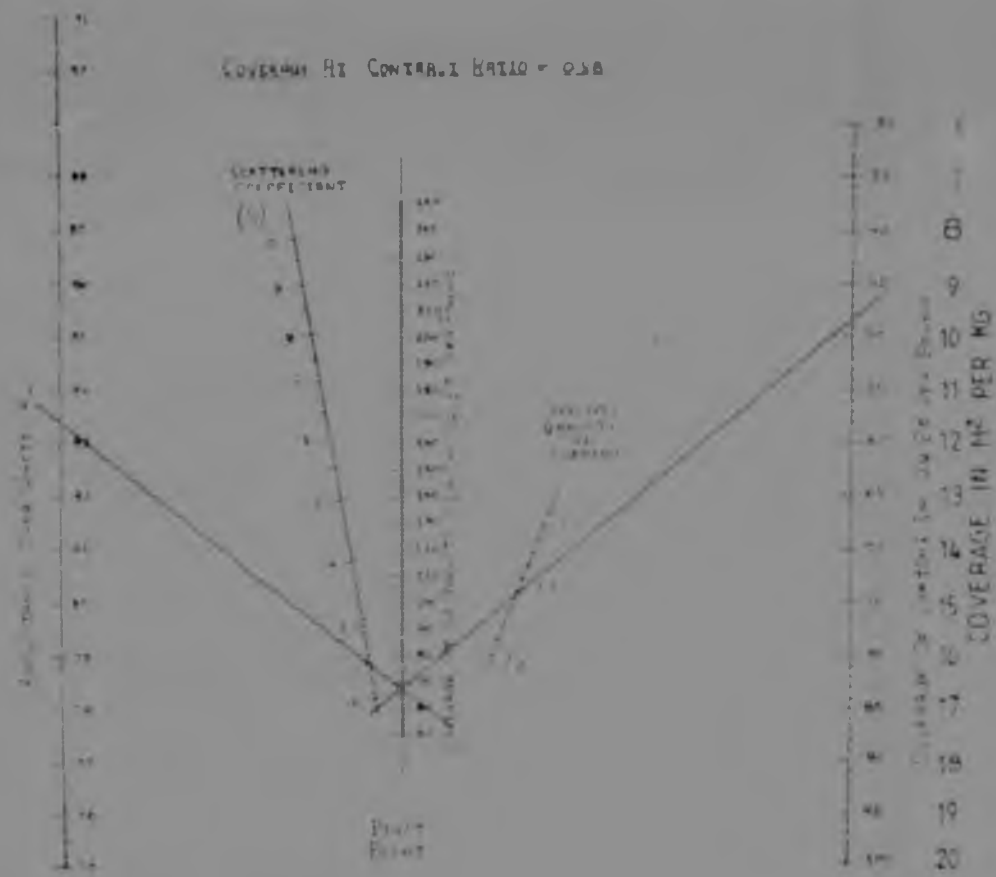

Figure 28

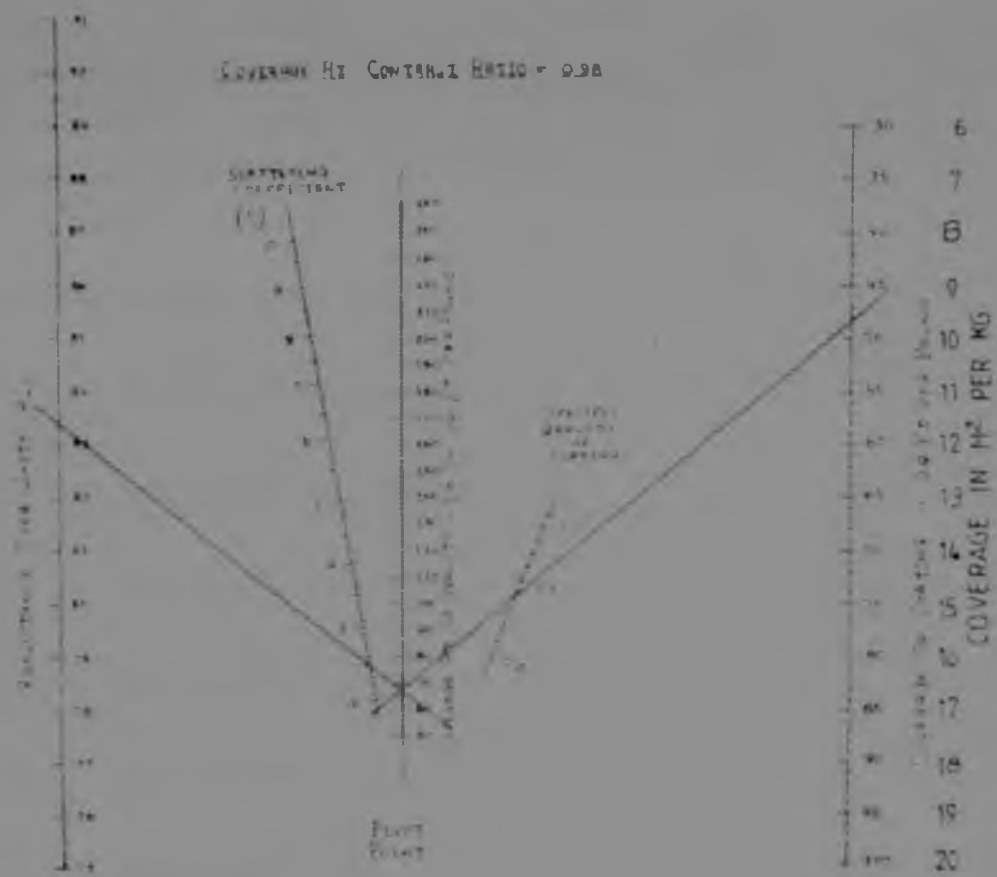

Figure 28

TABLE 15

DETERMINATION OF THE HIDING POWER OF SEVERAL POWDER COATINGS

	Powder 'A' (S.G. 1,54)		Powder 'B' (S.G. 1,74)	
	White Substrate	Black Substrate	White Substrate	Black Substrate
Coating Thickness ⁽¹⁾	73 microns ²	2,21-2,31 ³	92 microns	1,54 - 2,30
% Reflectance	83,3 ²	80,36-81,10 ²	90,25 ²	87,82 - 88,93 ³
Contrast ratio		0,970 ⁴		0,971 ⁴
S (5)		2,76 ⁴		4,21 ⁴
Coverage at C.R. = 0,98 ⁽⁶⁾		9,4m ² /Kg		10,2m ² /Kg
Thickness at C.R. = 0,98 ⁽⁷⁾		66 microns		56 microns

1. Calculated from equation 5
2. Average of three panels
3. Data from five panels
4. Average of five panels
5. From figure 27
6. From figure 28
7. Equation 8

TABLE 16

Effect of Hiding Power on the True Cost of A Coating

	<u>Powder 'A'</u>	<u>Powder 'B'</u>
Specific gravity	1,54	1,74
Coverage m ² /kg	25	22,5
Approx. selling price	R3,65/kg	R3,65/kg
Cost/m ² /25 microns	R2,96	R3,35
Difference - %	-	+13%

ASSUME that complete hiding is necessary for powder 'A' in the intended application.

Coverage m ² /kg	9,5	13,1
Thickness (2)	66 microns	43 microns
Cost to give equivalent appearance	R7,81	R5,76
Difference - %	-	- 35,6%

1. Equation 2
2. Equation 11

NOTE :

To decide now what powder should be used (clear or pigmented) would be impractical.

Consideration of the whole system should apply (systemic approach)

48.7 Cost of Coating

An average film thickness of 30 microns has been recorded throughout the experiments using clear film powders with average specific gravity of 1,6. For an average size sheet of 0,5m² we have $p = \frac{m}{v}$ but

Area x thickness x density = mass

$0,5 \times 30 \times 10^6 \times 1,6 \times 10^4 = \text{mass in Kg}$

$m = 24 \times 10^{-3} \text{ kg/sheet powder used}$

At approximately R4/kg of powder we get R0,096/sheet or 10 cents per sheet.

Costing structure within M.B. company would determine selling price.

Assuming, at this stage a 5c increase due to overheads and labour the induced cost/sheet would amount to R0,15/sheet.

48.8 Energy Consumption Analysis and Cost

The following presentation calculates an energy cost/ton based on the line parameters given before.

- * Line speed 500 sheets/hr = 500m/hr
- * Average sheet size 0,5m²
Must be noted that sheets would be passing through the oven with the smallest dimension running parallel to the conveyor direction.
- * Powder coating film thickness = 30 microns = $30 \times 10^6 \text{m}$
- * Specific gravity of powder = 1,6
- * Scale of simulation line to production line 1:4.
- * Recorded cure time per average size sheet = 1,1mins
- * Weight per sheet 2kg.

For a production rate of 500 sheets/hr weight amounts to 1 ton/hr.
Energy consumption as recorded approximately 43 Kw hr.

$$\text{Therefore} \quad \frac{43 \text{ Kw hr/hr}}{4 \text{ ton/hr}} = \frac{43 \text{ Kw hr}}{\text{ton}}$$

At an electric cost of Rx/Kw hr this translates to R 43x/ton.
Assuming an 8 hr shift at 43 Kwh/hr the total consumption
amounts to 344 Kwh/day. At a cost of approximately 1,2 cents
for the first 300 Kwh and at 1,02/Kw for amounts consumed above
300 Kwh the daily power cost would be approximately R405/day
or $\frac{R405}{8 \text{ tons}}$ or $\frac{R51}{\text{ton}}$

which when simplified relates to 1c/sheet processed.

The comment has been made that because of the ability to drop
the oven to an idle condition during line stoppage, no burned
product results. Line stoppages of this sort are frequent.

The control package has shown that the continual on and off
requirement can be accommodated by the power controllers.

49. Coating Thickness Measurement

The requirement to control the thickness of coatings grows at the same rate as the requirement to coat a material in order to enhance its appearance, improve its performance and change its characteristics.

As traditional materials become scarce or costly it becomes more economic to cover one material by another to achieve the required result. Because there is no truly universal method of measuring the thickness of coatings, various international, national and company internal specifications have been evolved, in an endeavour to standardise test procedures and so enable good correlation to be obtained between producer and customer. Coating thickness test methods may be divided into two sections, each section then sub-divided into the actual technique used. Therefore tests may be destructive and non destructive.

The major destructive tests are sub divided into microscopy and coulometric while the major non destructive techniques are eddy current, magnetic and beta backscatter.

49.1. Measurement Accuracy and Product Variation

Coated products contain thickness variations both across each single product and between products, thus, measuring the thickness it is necessary to know whether the figure quoted refers to a single product or to a product batch and in the case of the latter, where a product batch is large, sampling plans must be devised.

The classic illustration of a spread of results (or products) is via the Gaussian distribution.

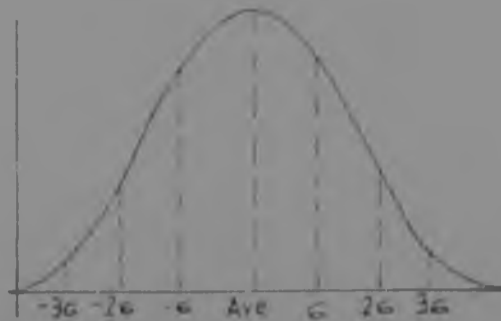

This curve shows that a range of thicknesses occurs either side of an average figure. (Curve not necessarily symmetrical). The distribution can be separated into 'four bands' below the average value and four bands above. The bands are separated along the x-axis by a value 6, the standard deviation.

$$\sigma = \sqrt{\frac{\sum (x_i - \bar{x})^2}{n-1}}$$

Mathematically, it can be calculated that 68,3% of the products lie between ± 6 , 95% between ± 26 and 97,5% between ± 36 . In practical terms, an average thickness value obtained from a product or group of products is of little use unless accompanied by its accuracy limits or tolerance under stated terms of security or confidence level.

In production of coating products it is uneconomic to produce to be '100% sure' that all the components satisfy a thickness limit, since the average figure at which the producer must aim his process would be disproportionately high. However, if the 'spread' of the process was reduced the average target figure is lower.

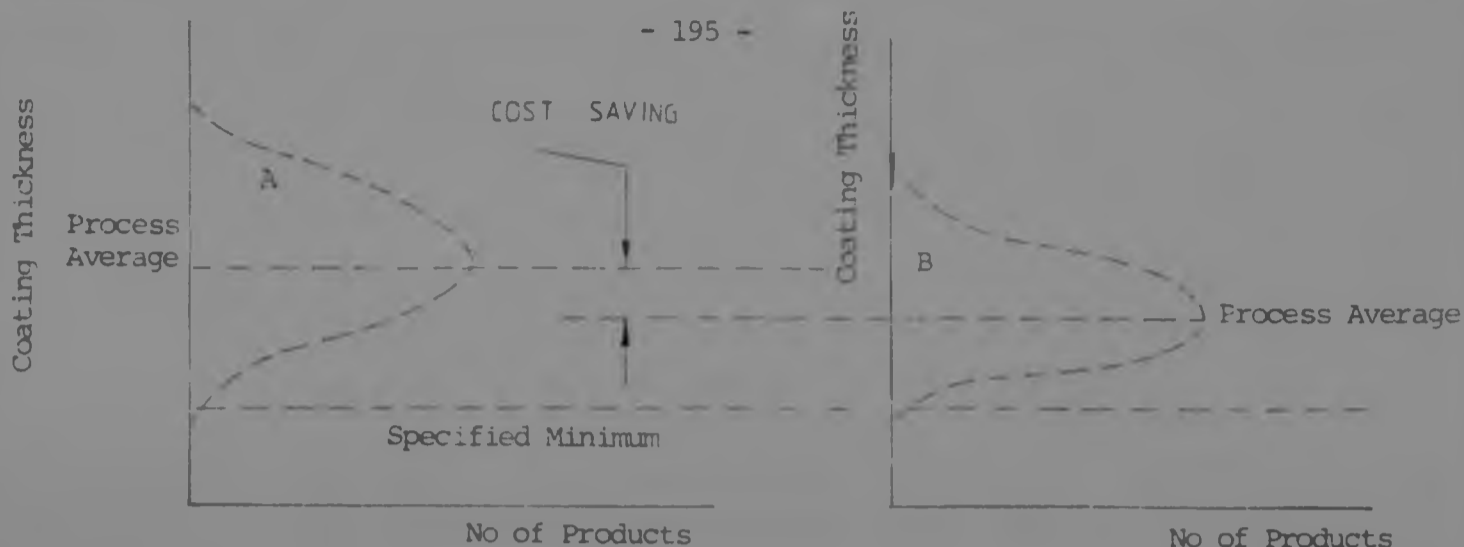

A manufacturer who quotes a coating thickness of 5 microns $\pm 5\%$ is not better than one who quotes $\pm 15\%$ if the first is given with a security of only 68,3% while the latter is quoted for 97,5%.

49.2 Different Test Areas

Test area delineation is probably the greatest single source of error in testing. The larger the test area used, the smaller becomes the error due to area, since for a given test cell, distortion introduces errors in dimensions which becomes proportionally less as test cell diameter increases.

49.3 Non Destructive Measurement of Coating Thickness

National specifications are dividing this principle into two parts : the instrument using magnetic fields derived from permanent magnets and those derived from electromagnetically stimulated sources. The latter method is the one now highly developed since the introduction of the first transistor, the integrated circuit and now the microprocessor. Electro-magnetic thickness gauges are equipped with either a single contact tip or a twin contact type of probe and a great deal of discussion has taken place in the past as to the merits of each one.

A popular misconception with the single pole probe is that it measures only where it touches ie at a point. This is not true since a magnetic field 'radiates' around the point.

In general terms, the smaller the area of probe influence, the better is the probe design. The twin pole probe, on the other hand, generates a strong magnetic field between the tips. This field is largely unaffected by influences outside the small area between the probe tips.

Although one should calibrate the electromagnetic thickness gauge by using a sample of the uncoated iron or steel, a technique now exists for some instruments by which the calibration can be confirmed and modified, without the existence of such a sample. This is of particular importance to those buying in coated components that have been processed by an outside company.

NOTE :

Single pole probe has been used throughout this experimental stage of producing thin film powder coatings.

In general terms, the smaller the area of probe influence, the better is the probe design. The twin pole probe, on the other hand, generates a strong magnetic field between the tips. This field is largely unaffected by influences outside the small area between the probe tips.

Although one should calibrate the electromagnetic thickness gauge by using a sample of the uncoated iron or steel, a technique now exists for some instruments by which the calibration can be confirmed and modified, without the existence of such a sample. This is of particular importance to those buying in coated components that have been processed by an outside company.

NOTE :

Single pole probe has been used throughout this experimental stage of producing thin film powder coatings.

50. Concluding Remarks

It is interesting to note that radical changes in powder application systems have only recently been introduced into commercial equipment. Coating efficiency and a true appreciation of back ionisation are now being seriously tackled and some of the latest equipment has been designed with these parameters very much in mind. In reality the likelihood of a gun system being capable of giving 100% coating efficiency must be very remote. Accepting this as a fact of life, then the obvious development route must be the optimisation of gun charging systems coupled with efficient reclamation of the overspray. Perhaps the most unpalatable comment which, nevertheless has to be made is the apparent reluctance of equipment manufacturers to adopt and innovate from some of the new ideas that have come from in depth research programmes. Very fundamental ideas are rapidly developed and commercial exploitation follows with equal rapidity.

This basic appreciation of fundamental research coupled with the ability to identify its commercial implications appears to be a characteristic sadly missing in many industries. It goes without saying that the quality of both pure and applied research carried out around the world is of the highest standard, but the responsibility for commercial exploitation lies fairly and squarely in the industrialist's court.

50. Concluding Remarks

It is interesting to note that radical changes in powder application systems have only recently been introduced into commercial equipment. Coating efficiency and a true appreciation of back ionisation are now being seriously tackled and some of the latest equipment has been designed with these parameters very much in mind. In reality the likelihood of a gun system being capable of giving 100% coating efficiency must be very remote. Accepting this as a fact of life, then the obvious development route must be the optimisation of gun charging systems coupled with efficient reclamation of the overspray. Perhaps the most unpalatable comment which, nevertheless has to be made is the apparent reluctance of equipment manufacturers to adopt and innovate from some of the new ideas that have come from in depth research programmes. Very fundamental ideas are rapidly developed and commercial exploitation follows with equal rapidity.

This basic appreciation of fundamental research coupled with the ability to identify its commercial implications appears to be a characteristic sadly missing in many industries. It goes without saying that the quality of both pure and applied research carried out around the world is of the highest standard, but the responsibility for commercial exploitation lies fairly and squarely in the industrialist's court.

50.1. Powder Recovery

Consideration has been given to the powder recovery systems existing in industry and the selection techniques involved for cyclones and dust collectors are mentioned.

However, to set up a complete powder coating system for production requirements, we would have to calculate -

1. Production requirements
2. No of spraying guns to be used
3. Type of conveyor
4. Powder flow rate Kg/hr
5. Powder consumption/day

For our purpose it was good enough to establish the basic design of the fundamental components involved in producing samples, which were tested.

51. CYCLONES

Abstract

Cyclone theory and its application to scale up from pilot test data is discussed. A test programme on various types of powders used in dry electrostatic spray coating is described, the results reviewed and the application of scale up technique to the test data to determine the performance of full scale cyclones is outlined.

The result, a complete selection of cyclones grouped by powder type with capacities ranging from 28 to 425 m³/min with pressure drops and collection efficiencies is presented in tabular form. Finally, cyclone features and accessories required for this application are described.

51.1. Introduction

The cyclone is one of the oldest most widely used and in its finished form one of the simplest pieces of equipment used in industrial processes. However, the accurate prediction of its performance is a highly complex problem in the fields of three dimensional, two phase fluid flow and the aerodynamics of fine particles. The first and basic principle of cyclone design and performance prediction is that the performance of a cyclone is determined, under a particular set of operating conditions, solely by the geometric configuration of the cyclone. The second principle is that a family of cyclones is defined when each member of the family is geometrically proportional to all other members. A given manufacturer's line of cyclones can therefore be completely defined by a number, N for each cyclone comprising the family. N for each cyclone in the family will generally be equal or related to (1) key cyclone dimension and is generally referred to as the cyclone size.

Cyclone performance is defined in terms of pressure drop and % collection efficiency by weight. Cyclone pressure drop is given by :

$$P = \frac{K_1 Q^2}{N^4} \quad - \quad (1)$$

P = Pressure drop

K_1 = An empirical constant including cyclone friction co-efficient
gas density and gas viscosity.

Q = Actual gas flow rate at cyclone inlet

N = Cyclone size

Cyclone efficiency is a complex function of:

1. The centrifugal acceleration acting on each particle.
2. The shape and mass of each particle, which can be expressed as Stokes equivalent diameter by measuring the terminal velocity of each particle in still air.
3. The density and viscosity of the gas.
4. The size and configuration of the cyclone.

A simplified version of the cyclone efficiency equation is

$$E = 1.0 - e^{-K_2 (a \cdot D_p)^{K_3}} \quad - \quad (2) \quad \text{where}$$

E = mass fraction collected at any particle size

K_2 = an empirical constant containing particulate density,
gas density and viscosity and cyclone size.

K_3 = an empirical constant

a = the centrifugal acceleration acting on each particle,
and,

D_p = particle sizes in Stoke's equivalent diameters.

The acceleration, a, in equation (2) can be expressed by :

$$a = K_4 \frac{Q^2}{N^5} \quad - \quad (3) \quad \text{where}$$

K_4 = an empirical constant for a particular family of cyclones.

$$P = \frac{K_1 Q^2}{N^4} \quad - \quad (1)$$

P = Pressure drop

K_1 = An empirical constant including cyclone friction co-efficient
gas density and gas viscosity.

Q = Actual gas flow rate at cyclone inlet

N = Cyclone size

Cyclone efficiency is a complex function of:

1. The centrifugal acceleration acting on each particle.
2. The shape and mass of each particle, which can be expressed as Stokes equivalent diameter by measuring the terminal velocity of each particle in still air.
3. The density and viscosity of the gas.
4. The size and configuration of the cyclone.

A simplified version of the cyclone efficiency equation is

$$E = 1.0 - e^{-K_2 (a \cdot D_p)^{K_3}} \quad - \quad (2) \quad \text{where}$$

E = mass fraction collected at any particle size

K_2 = an empirical constant containing particulate density,
gas density and viscosity and cyclone size.

K_3 = an empirical constant

a = the centrifugal acceleration acting on each particle,
and,

D_p = particle sizes in Stoke's equivalent diameters.

The acceleration, a, in equation (2) can be expressed by :

$$a = K_4 \frac{Q^2}{N^5} \quad - \quad (3) \quad \text{where}$$

K_4 = an empirical constant for a particular family of cyclones.

By substituting equation (3) in (2), fractional efficiency is expressed by :

$$E = 1,0 - e^{-K_2 \cdot K_4 \frac{(Q^2 \cdot D_p)^{K_3}}{N^5}} \quad - (4)$$

Referring to equations (1) and (4), the following classical cyclone performance characteristics are apparent:

1. Pressure drop varies directly with the square of the gas flow rate and inversely with the fourth power of the cyclone size.
2. Efficiency increases as a function of the square of gas flow rate and decreases as a function of cyclone size.
3. Because the efficiency equation for any cyclone in a family is similar, determination of efficiency in one cyclone permits scale up to any other member of the same family. Stated another way, if in two different cyclones of the same family there is the same acceleration, as given by (3), then, in each cyclone a particle having a given Stoke's diameter will reach the same terminal velocity. The difference in collection efficiency for that particle in each cyclone will vary only by difference in cyclone size as included in constant K_2 .

51.2 Purpose and Description of Test Programme

In 1980 Fisher-Klosterman, Inc. undertook to determine the collection efficiency and scale up relationship in high efficiency cyclones on typical powders used in dry electrostatic spray coating. Four commercial powders were tested abbreviated as 1, 2, 3, 4.

For each powder the test set up and test procedure were identical.

Author Kyriakou P

Name of thesis Investigation into the various parameters affecting the application of clear thermosetting powders by electrostatic spraying onto decorated tinplate and its ability to withstand tooling deformation without any noticeable breakdown. Included in the investig 1981

PUBLISHER:

University of the Witwatersrand, Johannesburg
©2013

LEGAL NOTICES:

Copyright Notice: All materials on the University of the Witwatersrand, Johannesburg Library website are protected by South African copyright law and may not be distributed, transmitted, displayed, or otherwise published in any format, without the prior written permission of the copyright owner.

Disclaimer and Terms of Use: Provided that you maintain all copyright and other notices contained therein, you may download material (one machine readable copy and one print copy per page) for your personal and/or educational non-commercial use only.

The University of the Witwatersrand, Johannesburg, is not responsible for any errors or omissions and excludes any and all liability for any errors in or omissions from the information on the Library website.