

SOME ASPECTS OF NAPPE OSCILLATION

by

Henry Ivan Schwartz

Thesis presented for the degree of Doctor of Philosophy in Engineering to the Faculty of Engineering, University of the Witwatersrand, Johannesburg, Republic of South Africa.

September, 1966

DECLARATION BY CANDIDATE

I hereby declare that the subject matter contained in this thesis is entirely my own work and has not previously been incorporated in a thesis for a degree at any other University

... *H. Ivan Schwartz* ...

H. Ivan Schwartz

Department of Civil Engineering
University of the Witwatersrand
Johannesburg
September, 1966

ACKNOWLEDGEMENTS

I am deeply grateful to Dr. D.C. Midgley, Professor of Hydraulic Engineering at the University of the Witwatersrand not only for initiating the project on which this thesis is based but also for valuable guidance and untiring assistance throughout the course of the work. My colleagues, Louis P. Nutt, Karl Posel and Ronald H. Mills are thanked for helpful discussions and ready assistance.

Special thanks are accorded to Dr. Eduard Naudascher of the Iowa Institute of Hydraulic Research who has shown continued interest in the work and was responsible for drawing to my attention associated researches into the mechanics of jet edge systems.

The assistance of the Director and staff of the University Computing Centre is much appreciated.

Finally, heartfelt thanks are due to my wife, Allison, to whom I owe so much for her patience and understanding.

ABSTRACT

The phenomenon of nappe oscillation has been actively studied for about thirty-five years without the emergence of an adequate explanation for its mechanism. In this work various aspects of nappe behaviour are investigated; the conclusion reached is that under certain circumstances a freely falling nappe can act with its air environment as a non-linear oscillating system consisting of an amplifier, a delay and a limiter. Amplification comes about because of the spread of nappe elements under the influence of transverse pressure variation, the delay is a function of the time of fall and the limiting action results from natural and self-actuated leakage of air.

Certain similarities between the phenomenon of nappe oscillation and that of edge tones are considered and some light is thereby thrown on the associated problem of jet-edge systems which has intrigued physicists for more than a century.

In the course of the investigation some interesting features of an applied mathematical nature emerge - for instance it is demonstrated mathematically that a body moving in a fixed direction and subjected to sinusoidal variation of transverse force would be deviated further from the original line of travel if the initial force were zero than if,

as at first sight might appear likely, the force were a maximum or a minimum. This curious fact is believed to have important implications in the fields of acoustics and hydrodynamics.

The research has also led to design recommendations for the spacing of splitters or nappe interruptors on dams (such as those raised by stressing cables) where the onset of nappe oscillation might be undesirable.

Some features of the phenomenon, such as the influence of boundary layer instability, remain unresolved and suggest promising topics for future research.

TABLE OF CONTENTS

ACKNOWLEDGEMENTS	(ii)
ABSTRACT	(iii)
LIST OF TABLES	(ix)
LIST OF FIGURES	(x)
I : INTRODUCTION AND REVIEW OF LITERATURE	
1.1 Introduction	1
1.2 Existing theories	4
1.3 Research in South Africa	11
1.4 State of knowledge in 1961	12
1.5 Recent publications	15
II : THE INFLUENCE OF STEADY DIFFERENTIAL PRESSURE ACROSS THE FACES OF PROJECTED SHEETS OF WATER	
2.1 Approach to problem	17
2.2 Projected nappes	18
2.3 "Water-bells"	19
2.4 Derivation of differential equation for trajectory of two dimensional nappe sub- ject to steady transverse pressure	20
2.5 Some observations on the curvature equation	23
2.6 Numerical solution	24
2.7 Typical values	25

2.8	Estimation of errors	26
2.9	Experimental corroboration	26
2.10	General solution for steady pressures	32
2.11	Comments on solution for steady pressures	36
III : THE EFFECTS OF HARMONIC PRESSURE ON FALLING SHEETS OF WATER		
3.1	Extension of analysis for steady pressures	38
3.2	Development of differential equation for nappe element subjected to harmonic pressure differentials	38
3.3	Establishment of the nappe form	39
3.4	Numerical solution	40
3.5	Check on cumulative errors	40
3.6	Compilation of computer program	43
3.7	Typical results and nappe profiles	43
3.8	Comment on results	44
IV : THE ' $K + \frac{1}{4}$ ' CRITERION		
4.1	Ratio of possible frequencies	50
4.2	Comparison of theory with nappe oscillation frequencies determined by Kemp and Pullen	50
4.3	Comments on ' $K + \frac{1}{4}$ ' criterion	52
4.4	Prediction of actual frequencies	53

4.5	Recorded frequencies	54
4.6	Effect of varying fall height	55
V	THE ENERGY BUDGET	
5.1	Energy absorption theory	60
5.2	Effective oscillation of nappe	60
5.3	Calculations for absorption	68
5.4	Effect of damping	70
5.5	Energy balance	71
5.6	Publication of energy absorption theory	73
VI	'LEAKAGE' THEORY	
6.1	Introduction to theory	74
6.2	Non-linearity of the system	74
6.3	Leakage analysis for cylinder	78
6.4	Typical numerical example	80
6.5	Application of leakage analysis to nappe oscillation	81
VII	ANALYSIS OF SYSTEM BEHAVIOUR	
7.1	Preliminary considerations	83
7.2	Retarded action	87
7.3	Non-linearity of the system	90
7.4	Time lag	91
7.5	Electrical analogue	92
7.6	Interpretation of analogue	96
7.7	Publication of delay theory	100

VIII : EDGETONES AND NAPPE OSCILLATION

8.1	A review of the literature on edgetones	102
8.2	Comparison between the edgetone and nappe oscillation phenomena	105
8.3	Trajectories of elements of a submerged jet	106
8.4	Publication on edgetones	108

IX : SUMMARY AND CONCLUSIONS

9.1	Self-excitation	113
9.2	The 'dynamical personality' of nappes	114
9.3	Conclusions and recommendations for further research	116

APPENDIX I	: Notation	120
------------	------------	-----

APPENDIX II	: Typical FORTRAN program for computer	124
-------------	--	-----

REFERENCES		126
------------	--	-----

LIST OF TABLES

Table Ref. No.		Page
2.1	Computed values of standard trajectory	27
4.1	Nappe oscillation frequencies determined experimentally by Kemp and Pullen	51
8.1	Analysis of observations taken from tables II and III of reference 56	111

LIST OF FIGURES

Fig. No.		Page
1.1	Oscillating nappe from model of raised spillway in transparent flume	5
1.2	Model showing effect of splitter on nappe	13
1.3	Nappe splitters on dam - design developed from hydraulic model study	14
2.1	Definition diagram showing co-ordinate system	22
2.2	Theoretical trajectories for various values of pressure difference across nappe	28
2.3	Effect on typical trajectories of doubling the unit discharge	29
2.4	Effect on standard trajectory of eliminating surface energy from the governing equation	30
2.5	Trajectories for fixed unit discharge at various values of initial velocity, v_0	31
2.6	Deflection versus pressure diagram	33
2.7	Diagram showing variation of 'stiffness modulus' with unit discharge	33
2.8	Nappe trajectories for various values of transverse pressure factor 'a'	35

3.1	Comparison of trajectories for discrete particle (as calculated by numerical analysis) with exact solution	41
3.2	Applied pressure	45
3.3	Trajectories of elements	45
3.4	Trajectories and nappe profiles for 8 c/sec	46
3.5	Trajectories and nappe profiles for 10 c/sec	46
3.6	Enlarged detail of trajectories near origin for 8 c/sec	47
3.7	Diagrammatic nappe profiles showing positions of particles at two selected intervals within a cycle	48
4.1	Frequencies computed by use of equation 4.1 for successive values of the integer K showing observed data from several sources (natural scales)	56
4.2	Frequencies computed by use of equation 4.1 for successive values of the integer K showing observed data from several sources (logarithmic scales)	57
4.3	Variation of frequency with fall distance exhibiting hysteretic behaviour	59

5.1	Computed profiles of typical nappe subject to sinusoidal pressure variation: f = 454 c/min	61
5.2	Simplified diagrammatic representation of lowermost five quarter periods of nappe showing pumping and absorption zones	62
5.3	Diagrammatic nappe showing force, displacement and damping relationships at selected elevations	65
5.4	Typical computed values of final quarter wave-length and its product with frequency	66
6.1	Nappe exhibiting oscillation at a frequency of 460 cycles per minute	75
6.2	Nappe exhibiting oscillation at a frequency of 600 cycles per minute	76
6.3	Definition sketch for leakage analysis	77
7.1	Circuit diagram for non-linear oscillator with delay	93
7.2	Diagram illustrating the mode of establishment of a quasi-stable amplitude	95
7.3	Diagram illustrating the degree of sensitivity of nappes subject to various times of fall	99

I. INTRODUCTION AND REVIEW OF LITERATURE

We must "look upon all jets
as musically-inclined"

John LeConte

1.1 Introduction

Four years ago the author embarked upon a study of an imperfectly understood hydro-elastic vibration, nappe oscillation - a phenomenon in which thin sheets of water discharging freely from long weirs appear to fluctuate violently at a particular frequency that remains virtually constant as long as the water continues to flow at a steady rate.

In this thesis the course of the investigation is traced and it will become evident that although the primary objective of the research was confined to determination of the mode of action of water oscillating in an air medium the findings may well provide a pointer to the understanding of the behaviour pattern of several other obscure oscillatory phenomena.

Nappe oscillation has been encountered on several dams raised by the stressed cable technique, on drum gates fitted on weir crests and occasionally on natural waterfalls. Alarming movements of air accompany the oscillations and the noise generated by the intense vibration can be extremely trying. Although the motion broadcast is small it can be magnified by resonance with the result that windows at distances of up to half a mile from the source of the oscillations have been known to rattle and even shatter under the influence of the radiated pressure waves.

It is usually considered that the oscillations of water overflowing solid weirs are unlikely to lead to structural failure and that the phenomenon merely constitutes a profound nuisance. Natural frequencies of dams in bending and compressional modes may, however, be of the same order^{1*} as, or harmonics of, the oscillation frequencies and the possibility of dangerous resonating conditions should therefore receive the serious consideration of dam designers. Manufacturers of drum crest-gates generally take special precautions to suppress oscillations since there exists the very real danger that vibrations would result in damage to mechanical appurtenances under resonance conditions.

*References are listed on pages 126 et. seq.

In recent years intensified research effort has been directed towards the problems of vibration associated with hydraulic structures²; nappe oscillation in particular has been studied for more than three decades, although mainly as an incidental study, by research workers primarily concerned with the effect of vibration on crest gates. The French hydraulician Pierre Danel relates that the noted aerodynamicist Theodor von Kármán, whilst visiting his laboratories at Grenoble in 1946, stood fascinated before a model of an oscillating nappe for more than two hours after which he said that he could offer no rational explanation for the phenomenon.

Nature's ways are rarely simple. So complex are the underlying causes of nappe oscillations that several widely differing theories, some based on pure conjecture, have been advanced. Not one has adequately accounted for all the observed facts pertinent to the problem.

Reasonably effective means of suppressing or even eliminating the oscillations have been found, but the measures employed have been established mainly on an empirical basis because incomplete knowledge of the mechanics involved has precluded the formulation of reliable design criteria. It has been found possible to reproduce nappe oscillation on a comparatively small scale in the

laboratory, but it is clear that without proper understanding of the basic mechanics hydraulic engineers would be unable to interpret satisfactorily the results of such model tests.

Ordinarily, oscillations cannot be established with the limited heights of fall available in conventional laboratory flumes, but some years ago it was found by the writer that if the air current generated by a fan were directed on to a steady nappe in a model, oscillations would often be induced where none previously existed. The frequency of such oscillations is too high for the eye to distinguish the curvaceous form of the water so apparent on a short-duration ($1/1000$ second or less) photographic exposure (see, for example, Figure 1.1). Close examination of Figure 1.1 reveals that not only do horizontal corrugations appear but that ribs of water with axes in the direction of the stream are present, thus indicating the existence of some secondary phenomenon. The regularity of the ribs and furrows is noteworthy and the spacing of the ribs appears to be a function of the frequency of oscillation.

1.2 Existing theories

A comprehensive survey of the literature revealed that fairly considerable study had been devoted to the theory of nappe oscillation, particularly by research

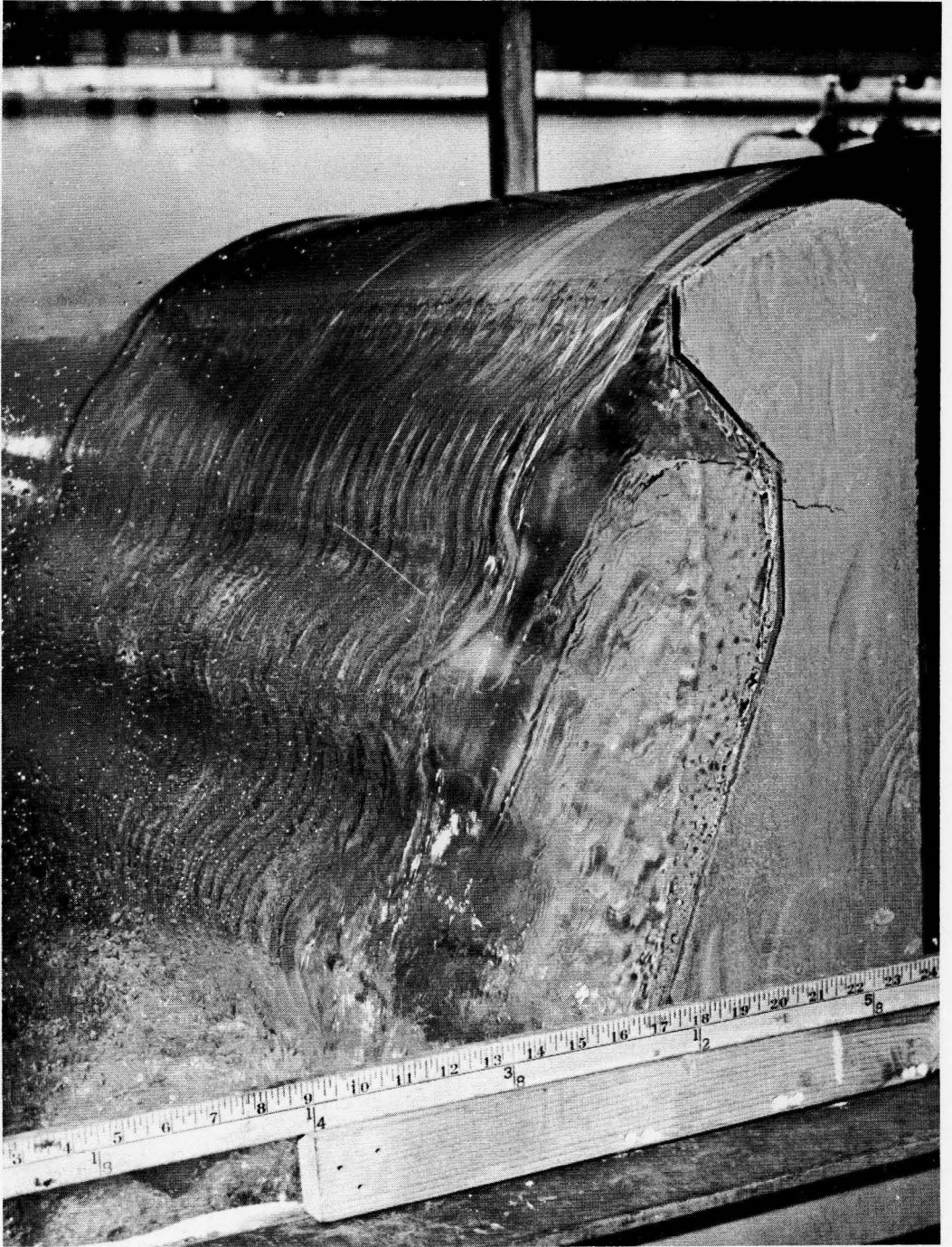

FIGURE 1.1

OSCILLATING NAPPE FROM MODEL OF RAISED
SPILLWAY IN TRANSPARENT FLUME
(FLASH DURATION 1/1000 SEC)

workers in Germany and France. Some studies had been carried out in the United States of America before World War I and more recently attention had been given to the problem in South Africa.

In the early thirties German research workers contended that noise generated by the water falling on the apron or tailwater was fed back to the crest in the form of pressure pulsations in the air space beneath the nappe. Other investigators believed that changes in the volume of the trapped air caused the vibration. Several theories involving surface tension forces, roll waves, resonance of the air space and organ pipe effects were advanced and in 1934 Fuhrmann³ suggested a formula based on the physics of sound tubes which seemed plausible but which was subsequently shown by Pariset⁴ to be unrealistic for the practical cases considered.

Dr. Otto Müller⁵ treated the problem of nappe vibrations by analogy with those generated by radio transmitters and reed pipes but his theories did not accord fully with experimental evidence.

Kurt Petrikat⁶, at present Professor at the Technische Hochschule in Stuttgart but at one time chief engineer of a large industrial organization that manufactures crest gates for dams, made a detailed study of oscillations produced by the elasticity of flap-gates.

Fixed weirs were considered by Petrikat to be a special case in application of formulae derived for movable flaps and as an example a particular masonry weir at Hameln (where oscillation was referred to as "weir flutter") was cited. Whilst correctly attributing the cause of the phenomenon of oscillation to variations in pressure in the air space beneath the nappe, Petrikat stated that the frequency, n , was determined by the thickness of the jet and the air volume according to the expression

$$n = \frac{1}{2\pi} \left(\frac{d_1}{m}\right)^{\frac{1}{2}} = \text{approx. } 3 \text{ to } 5 \text{ sec}^{-1},$$

where d_1 denotes the 'elasticity coefficient' of the air space and m the mass of the falling water.

The wave length for the weir at Hameln was stated to be given by $\frac{v}{n} = 0.5 \text{ to } 2.0$ metres, where v is undefined but is presumably a velocity and n is the frequency of the oscillation. "As a result", it was stated, "2 to 4 undulations depending on the head will be seen moving downward at the speed of free fall."

In 1940, Seifert⁷ summarized the state of knowledge on the subject and discussed various types and arrangements of splitters developed in his laboratories. These splitters, it was reported, worked fairly well in suppressing vibrations of flap gates; yet it was acknowledged that under certain conditions the splitters proved ineffective.

Fischer⁸, Peters⁹ and others studied various aspects of the problem and Peters, by isolating the apron from the body of the weir, demonstrated that the feed-back system sustaining oscillations did not occur through the medium of the structure itself.

The phenomenon of oscillation associated with drum gates at Black Canyon Dam was investigated by Glover et al¹⁰ of the United States Bureau of Reclamation and it was reported that vibration was eliminated by aerating the space under the nappe by means of a log attached to the piers by cables.

Several pressure readings were taken with carefully calibrated carbon-pile and moving-coil pressure cells; the maximum pressure recorded was about 8.7 lb/sq. ft. and the frequencies ranged from 7 to 18 cycles per second.

A tentative theory based on fluctuations in air pressure caused by air flowing in at the ends of the nappe at a variable rate following variations in air entrainment efficiency was advanced by Glover and his associates. It was realized that the theory was totally inadequate and recommendations were made to the effect that the causes of vibrations be further investigated.

Campbell² reported that Bruno Leo had carried out extensive tests on the subject but difficulty was experienced in procuring a copy of the reference cited.

A copy of the text (without diagrams which, as a result of war damage, were not fit for reproduction) was eventually received in November 1964 direct from the Waterways Experiment Station of the U.S. Army Corps of Engineers.

Dr. Leo¹¹ recognised that the problem of gate (or shutter) vibrations differed in many respects from that of nappe vibration. He developed a mathematical expression for the nappe configuration at any chosen instant of the cycle. Unfortunately, pressure effects on water elements after they had detached themselves from the weir lip were neglected and this omission led to certain inconsistent conclusions regarding the behaviour of the nappe. Leo realised that there was an unexplained difference of about half a cycle between his mathematical prediction and experimental evidence and he offered an ingenious explanation to account for the discrepancy.

Leo also distinguished between ordinary slow vibrations and 'acoustic vibrations' which, he claimed, produce the so-called humming of weirs. On the three types categorised - shutter vibration, nappe vibration and air vibration - Leo felt that the shutter vibrations were most important from the engineering viewpoint but that the difficulties encountered in computing the processes involved in nappe vibration were much greater than in the other two cases.

One of the most comprehensive analyses of the problem was presented in 1955 at the sixth general meeting of the International Association for Hydraulic Research by Pariset⁴ who reviewed the state of knowledge existing at that time and then advanced a theory based on the fact that the air space beneath the nappe acted as a link which sustained the phenomenon. It was contended that the waviness was due to changes in direction with which the sheet of water left the weir and that the condition was similar to that which obtains when the jet of a garden hose is periodically agitated by keeping the position of the discharge end fixed and wagging the nozzle.

Pariset reasoned that the number of periods, "a", would be some integer K plus $\frac{3}{4}$ plus ' a delay due to inertia' and that self-sustained oscillations would occur only when variations in pressure at the foot of the nappe arrived at the weir in phase with movement from the top of the nappe. Experiments showed, it was claimed, values of "a" to lie between 0.52 and 0.95, the error being attributed to the lack of precision with which the frequency could be measured. Pariset reported that in general the value of "a" was about 0.85. It does not seem feasible, however, for him to have determined accurately the number of periods either by observation under stroboscopic light or by examination of photographs.

Further work by Pariset included investigations into the influence of aeration and into the effect of placing a castellated sill along the apron with the stated objective of cancelling volume changes in the lowermost half-wave.

In his conclusion Pariset stressed that the mathematical formulae presented were based on intuitive reasoning rather than on rigorous calculation and that he was fully aware that the basis for his computations for spacing of splitters was not strictly correct; his presentation was intended as a partial explanation of the phenomenon and as a guide to further studies.

1.3 Research in South Africa

Whilst visiting Europe in 1957 Professor D.C. Midgley of the University of the Witwatersrand discussed the problem of oscillation with several research workers. In 1960 he was asked to examine a dam which had recently been raised by stressed cables and upon overflowing exhibited troublesome nappe vibration. He recommended decreasing the spacing of nappe interruptors to overcome the immediate difficulty but encouraged the writer to undertake an intensive study of the phenomenon. Some months later Professor Midgley and the writer were called upon for advice when another dam was to be raised by the use of stressed cables. By this time it had become possible to reproduce the phenomenon of oscillation in a laboratory flume with

the aid of a fan and the writer was able to evolve a new design of splitter from model tests.

Figure 1.2 illustrates the mode of behaviour of the improved splitter on model scale and Figure 1.3 is a photograph of the raised dam fitted with the recommended splitters which later proved to be effective in suppressing oscillations.

Under the direction of the author several final year civil engineering students at the University of the Witwatersrand constructed models and carried out various experimental investigations. Among these were Carman¹³ (1960) and Kemp and Pullen¹⁴ (1961). General agreement on the validity of Pariset's theory was not reached but despite the lack of conclusive findings the studies were invaluable because several reliable frequency observations were placed on record.

Students at the University of Stellenbosch investigated the problem, and the overflowing nappe on a model of Tweerivieren Dam near Port Elizabeth constructed by engineers of the Department of Water Affairs was known to have exhibited tendencies towards instability.

1.4 State of knowledge in 1961

By the end of 1961 the nature of the mechanism of oscillation had not been established although it did

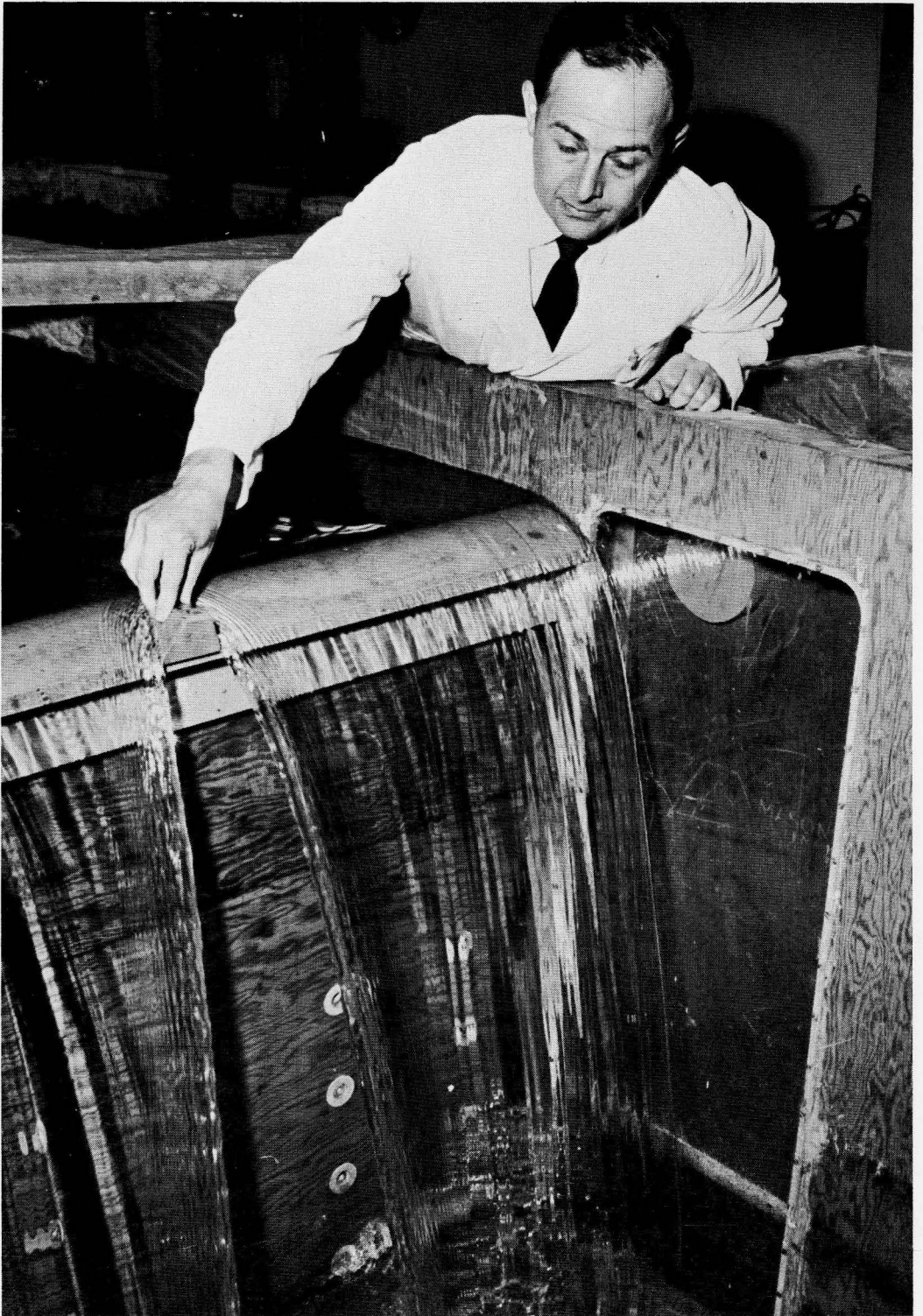

FIGURE 1.2

MODEL SHOWING EFFECT OF SPLITTER ON
NAPPE

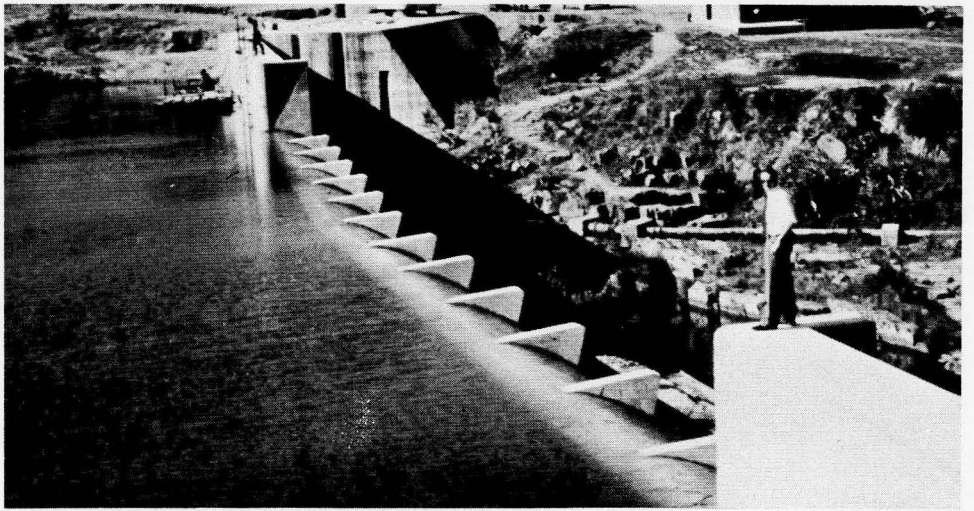

FIGURE 1.3

NAPPE SPLITTERS ON DAM — DESIGN
DEVELOPED FROM HYDRAULIC MODEL STUDY

seem reasonably certain that the air space beneath the nappe was in some way responsible for the hydro-elastic vibrations.

Petrikat, in a private discussion with Professor Midgley in 1961, stated that he felt that his early researches were not altogether correct and that he had come to believe that the onset of the phenomenon was analagous to the incipience of wave formation in the ocean.

Examination of publications listing research projects in almost all the major hydraulic institutions of the world revealed that although a fair amount of attention was being devoted to hydraulic oscillations, it was only at this University that nappe oscillation was being actively studied. The writer was accordingly prompted to embark upon the intensive investigation which led ultimately to presentation of this thesis.

1.5 Recent publications

In September 1963, the tenth congress of the International Association for Hydraulic Research was held in London and at special sessions devoted entirely to the topic of hydro-elastic vibrations twenty-six papers were submitted. Although several authors referred to the work of Petrikat and Pariset no original contribution on the subject of nappe oscillation was presented.

The Soci  t   Hydrotechnique de France, at a

conference held at Lille in June 1964, also discussed instability in several fields and one of the papers 'Etude en laboratoire de la vibration des lames déversant' by J. Rigard¹⁵ summarised the investigations undertaken at the SOGRÉAH laboratory in the nine-year period following Pariset's report of the problem at the 1955 IAHR Congress. Rigard recapitulated the work of Pariset without any significant additions and stated that periodic phenomena in spillway overflow sheets still lacked satisfactory explanation.

In July 1965, in a paper by Simmons¹⁶, the work reported by Glover et al in 1939 was restated, also without any notable advances.

II. THE INFLUENCE OF STEADY DIFFERENTIAL PRESSURE ACROSS THE FACES OF PROJECTED SHEETS OF WATER

2.1 Approach to problem

At the outset, several months were spent by the author in observing various characteristics of nappe oscillation in the laboratory and in delving into the literature on such unrelated but seemingly fruitful subjects as acoustics, the physics of organ pipes and loud speaker cabinets, surface tension effects, boundary layer oscillations, instability in curvilinear flows, aeronautics (with special reference to wing flutter) and others.

The effect of roughening the weir crest on a model was investigated and it was found that the trajectory of the falling water was steepened appreciably and that oscillations were suppressed.

This led to the speculation that the mechanism of nappe oscillation was governed by boundary-layer instability and an award-winning short paper¹⁷ based on these experiments was published in the Transactions of the South African Institution of Civil Engineers in July 1962.

The measurement of the small and rapidly varying pressures involved could not readily be accomplished by the use of existing techniques and as investigations proceeded

it became increasingly evident that nappe oscillation was so complex that further accumulation of empirical data would be of little help and that only a thorough analytical investigation of the mechanics of the phenomenon would reveal which factors were important and which could safely be ignored. Accordingly, the author decided to carry out a systematic mathematical analysis of the effects of air pressure, gravity and surface tension forces on a falling sheet of water.

For preliminary study the simplest case of steady air pressure was selected.

2.2 Projected nappes

A paper by Blaisdell¹⁸ (1954) in the Proceedings of the American Society of Civil Engineers included results gathered from various sources for nappe trajectories of projected water not subject to transverse pressure and equations for the trajectories were given.

Woronetz¹⁹ (1954) published equations which took account of the effect of steady transverse pressure on nappes projected horizontally but surface tension was not included among the variables in his solution. For the study of nappe oscillation, however, it was felt that neglect of surface tension could not be justified until the relative influence of surface tension and transverse pressure forces had been established.

Accordingly, further research was carried out into the mathematical basis of surface tension determinations. This work led to the realization that nappes from dams were the two-dimensional counterpart of "water-bells". It may be of interest to record here that two years later N. Porter²⁰, an undergraduate student in the Department of the Mechanical Engineering at this University, had observed and studied oscillations on water-bells.

2.3 "Water-bells"

A search of the literature revealed that as early as 1833 Savart²¹ had described the behaviour of the liquid film produced when a vertical jet of water impinges upon a horizontal circular disc.

About one hundred years later several physicists used the theory of water-bells to determine the surface tension of certain liquids but the method fell into disfavour when inconclusive results were obtained. The fact that results were not reproducible is not surprising when, as is proved later, it is appreciated that minute pressure differences following upon air entrainment cause significant deflections in the trajectory of a thin sheet of water.

Hopwood²² (1952) revived interest in studies of water-bells when at a *Conversazione* of the Physical Society of London he demonstrated some of the remarkable shapes -

both stable and unstable - that could be produced with simple apparatus. He recalled the expressions that had been derived by Boussinesq²³ (1869, 1913) for determination of surface tension by means of liquid bells.

Lance and Perry²⁴ (1953) recast the equations of motion derived by Boussinesq and by a process of numerical integration, based on Euler's polygon method, calculated bell shapes for specific values of various parameters.

Later, Lance and Deland²⁵ (1955) presented further results obtained with the aid of a mechanical differential analyser. An interesting feature of these solutions is that under certain conditions of pressure difference the nappe should theoretically "loop-the-loop". Since this is not physically possible an angular cusp is formed as can be verified experimentally with water-bells.

2.4 Derivation of differential equation for trajectory of two-dimensional nappe subject to steady transverse pressure

Application of the principle of continuity and the equations of motion in directions normal and tangential to the trace of an element of falling water leads to a second order non-linear differential equation which describes the trajectory of each particle. An outline of the analysis follows:-

Consider a small element of length δs and width

b as shown in Figure 2.1. The co-ordinate system is chosen with origin at the line or source of free discharge and positive directions as shown. For an incompressible fluid application of the principle of continuity results in the following relationship:-

$$Q = qb = bhv^* \quad \dots \quad 2.1$$

The equation of motion in the tangential direction is

$$g \sin \phi = v \frac{dv}{ds} \quad \dots \quad 2.2$$

which by substitution of the equation

$$dy = ds \sin \phi$$

and integration, gives

$$v^2 = v_0^2 + 2gy \quad \dots \quad 2.3$$

The equation of motion in the normal direction is

$$2\sigma b \, d\phi + \gamma \, ds \, h \, b \, \cos\phi + (P-p)b \, ds = \frac{\gamma}{g} \, bhv^2 \, \frac{d\phi}{ds} \, ds$$

$$\text{or} \quad \frac{2\sigma}{R} + \gamma h \cos\phi + (P-p) = \frac{\rho h v^2}{R} \quad \dots \quad 2.4$$

$$\text{where} \quad R = \frac{ds}{d\phi}$$

$$\text{Let the pressure factor } \alpha = \frac{(P-p)b}{Qv_0}$$

$$\text{and the surface energy factor } \beta = \frac{2\sigma b}{Qv_0}$$

*For notation see Appendix 1.

Initial angle ϕ_0

Initial velocity v_0

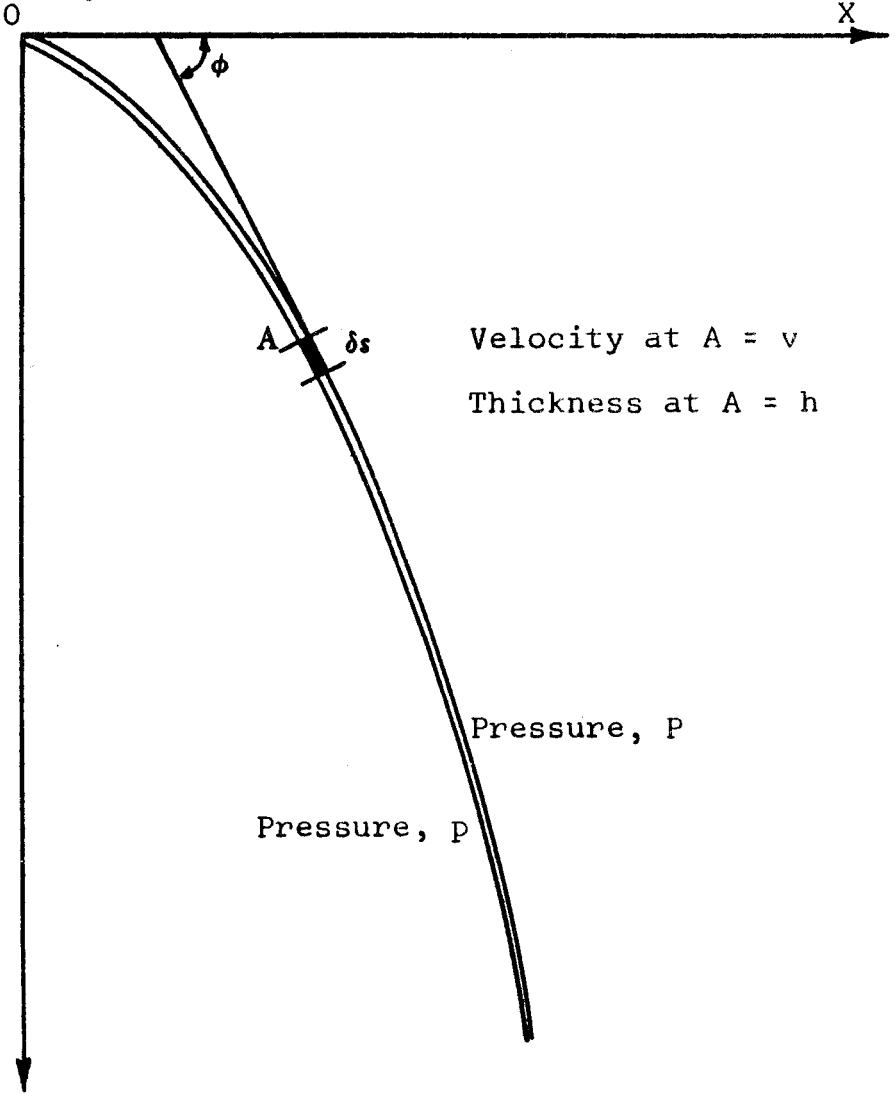

Velocity at A = v

Thickness at A = h

Pressure, P

Pressure, p

FIGURE 2.1

DEFINITION DIAGRAM SHOWING CO-ORDINATE SYSTEM

Then equation 2.4 reduces to

$$\frac{\beta}{R} + \frac{\gamma \cos \phi}{v v_0} + \alpha = \frac{\rho v}{R v_0}$$

By putting $\lambda = \frac{v_0^2}{2g}$ and using equation 2.3 the velocity can be expressed as

$$v = \{v_0^2 + v_0^2(y/\lambda)\}^{\frac{1}{2}} = v_0 \epsilon$$

where $\epsilon = \{1 + \frac{y}{\lambda}\}^{\frac{1}{2}}$

By substitution the following expression for the curvature may be obtained:-

$$K = \frac{1}{R} \frac{\alpha + \frac{\rho \cos \phi}{2\epsilon \lambda}}{\rho \epsilon - \beta} \quad \dots \quad 2.5$$

The equation can be re-written thus:-

$$y'' \{ \rho (1 + y/\lambda)^{\frac{1}{2}} - \beta \} = (1 + y'^2)^{3/2} \left\{ \alpha + \frac{\rho}{2\lambda (1 + y/\lambda)^{\frac{1}{2}} (1 + y'^2)^{\frac{1}{2}}} \right\} \quad \dots \quad 2.6$$

2.5 Some observations on the curvature equation

Equation 2.6 was clearly not amenable to analytical solution but inspection revealed that an approximate solution involving the expression for radius of curvature, R, in equation 2.5 could be obtained by relatively straightforward numerical methods.

When $y = 0$ it can be seen that the value of the denominator of the curvature equation is $(\rho - \beta)$ and that

unless the product of q and v is of the same order as the value of surface energy the influence of the surface energy factor is comparatively minor. As y increases the influence is further reduced.

It thus became possible to determine the relative importance of surface energy in comparison with the effects of differential pressure which, as is evident from the equation, exerts considerable influence on both the magnitude and sign of the curvature.

In order that the relative effects of the various parameters might be examined the numerical solution was programmed in the FORTRAN language for the IBM 1620 model I electronic computer at this University. Several typical solutions were evaluated and are reproduced in section 7 of this chapter.

2.6 Numerical solution

The numerical method of analysis adopted is based on the method suggested by Lance and Perry²⁴ and consists fundamentally in following the curve from known co-ordinates and projection angle along small increments such that the differential equation is satisfied at all stages.

The required equations are derived from trigonometrical relationships and are as follows:-

$$X_{n+1} = X_n + 2R_n \sin \theta \cos(\phi_n + \theta)$$

$$Y_{n+1} = Y_n + 2R_n \sin \theta \sin(\phi_n + \theta)$$

$$\text{and } \phi_{n+1} = \phi_n + 2\theta$$

where 2θ equals the angle subtended by the incremental arc.

2.7 Typical values

At first the angle θ was held constant but for small values of curvature the increments of arc became excessive. The program was accordingly adjusted to permit a constant value of increment to be chosen while the angle was allowed to vary.

All results presented in this section are based on increments of arc of 0.01 ft. Standard values of parameters chosen as a basis for comparison were as follows:-

$$\text{Unit discharge } q = 0.025 \text{ cusec/ft width}$$

$$\text{Initial velocity } v_0 = 3.00 \text{ ft/sec}$$

$$\text{Surface energy } \sigma = 0.005 \text{ lb.ft/ft}^2$$

$$\text{Specific weight } \gamma = 62.4 \text{ lb/ft}^3$$

$$\text{Gravitational constant } g = 32.2 \text{ ft/sec}^2$$

$$\text{Angle of projection } \phi_0 = 38^\circ \text{ downward from the horizontal}$$

$$\text{Pressure difference (P-p)} = 0.0 \text{ lb/ft}^2$$

The computed values for this standard condition are listed in Table 2.1.

The trajectories plotted on Figures 2.2 to 2.5 show the relative influences of changes in the various parameters. It was immediately evident from these results that small pressures not easily detected on ordinary pressure measuring devices could appreciably alter the trajectory of falling water.

2.8 Estimation of errors

At this stage of the investigation it was difficult to estimate the degree to which errors in the trajectories could be attributed to uncertainties in the numerical solution but a check made on the standard trajectory using an increment of 0.005 ft throughout yielded a result but little different from that computed with an increment of 0.01 ft. This lent confidence to the use of the procedure but, since the computer calculation time for each trace was lengthened from about forty minutes to seventy-five minutes by employment of the smaller increment, the increased accuracy was considered to be not warranted.

2.9 Experimental corroboration

The results of the analysis described in this chapter were presented in a paper²⁶ to the South African Institution of Civil Engineers published in January 1963 and in discussion of the paper Kilner²⁷ described an experimental investigation that had been carried out under

Table 2.1 - Computed values of standard trajectory

x co-ordinate ft	y co-ordinate ft	Radius of curvature* ft	Angle θ Degrees
0.0000	0.0000	0.330	38.00
0.0702	0.0708	0.632	51.04
0.1276	0.1526	0.106 x 10	58.23
0.1766	0.2397	0.159 x 10	62.74
0.2199	0.3299	0.221 x 10	65.85
0.2588	0.4220	0.291 x 10	68.14
0.2946	0.5154	0.369 x 10	69.90
0.3277	0.6097	0.454 x 10	71.32
0.3588	0.7048	0.545 x 10	72.48
0.3880	0.8004	0.643 x 10	73.45
0.4158	0.8965	0.746 x 10	74.29
0.4422	0.9929	0.856 x 10	75.01
0.4676	1.0896	0.969 x 10	75.64
0.4919	1.1866	0.109 x 10 ²	76.20
0.5153	1.2839	0.121 x 10 ²	76.70
0.5379	1.3813	0.134 x 10 ²	77.16
0.5597	1.4789	0.147 x 10 ²	77.57
0.5809	1.5766	0.161 x 10 ²	77.94
0.6015	1.6744	0.175 x 10 ²	78.28
0.6216	1.7724	0.190 x 10 ²	78.60
0.6411	1.8705	0.205 x 10 ²	78.89
0.6601	1.9687	0.220 x 10 ²	79.16
0.6787	2.0669	0.236 x 10 ²	79.41
0.6969	2.1653	0.252 x 10 ²	79.65
0.7146	2.2637	0.268 x 10 ²	79.87
0.7320	2.3621	0.286 x 10 ²	80.07
0.7491	2.4607	0.303 x 10 ²	80.27
0.7658	2.5593	0.321 x 10 ²	80.45
0.7823	2.6579	0.338 x 10 ²	80.63
0.7984	2.7566	0.357 x 10 ²	80.79
0.8142	2.8553	0.375 x 10 ²	80.95
0.8298	2.9541	0.394 x 10 ²	81.10
0.8452	3.0529	0.414 x 10 ²	81.24
0.8603	3.1518	0.433 x 10 ²	81.38
0.8751	3.2507	0.453 x 10 ²	81.59
0.8898	3.3496	0.473 x 10 ²	81.63
0.9042	3.4485	0.494 x 10 ²	81.75
0.9185	3.5475	0.514 x 10 ²	81.86
0.9325	3.6465	0.535 x 10 ²	81.97
0.9464	3.7455	0.557 x 10 ²	82.08
0.9601	3.8466	0.578 x 10 ²	82.18
0.9736	3.9437	0.600 x 10 ²	82.28
0.9870	4.0428	0.623 x 10 ²	82.37
1.0001	4.1419	0.645 x 10 ²	82.46
1.0132	4.2411	0.668 x 10 ²	82.55
1.0261	4.3402	0.691 x 10 ²	82.63
1.0388	4.4394	0.714 x 10 ²	82.71

*Radius of curvature was actually calculated to 8 significant figures

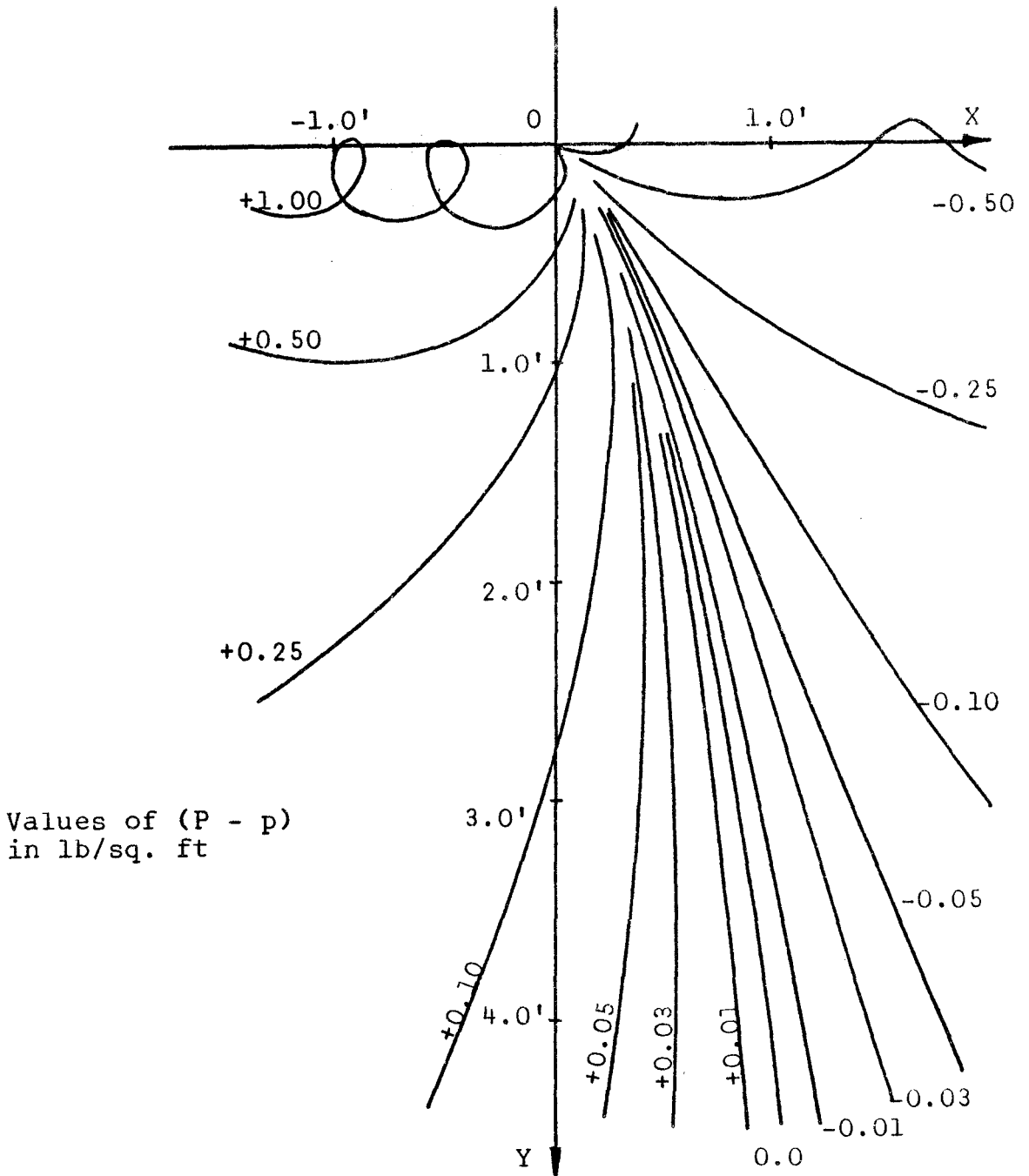

FIGURE 2.2

THEORETICAL TRAJECTORIES FOR VARIOUS
VALUES OF PRESSURE DIFFERENCE ACROSS
NAPPE

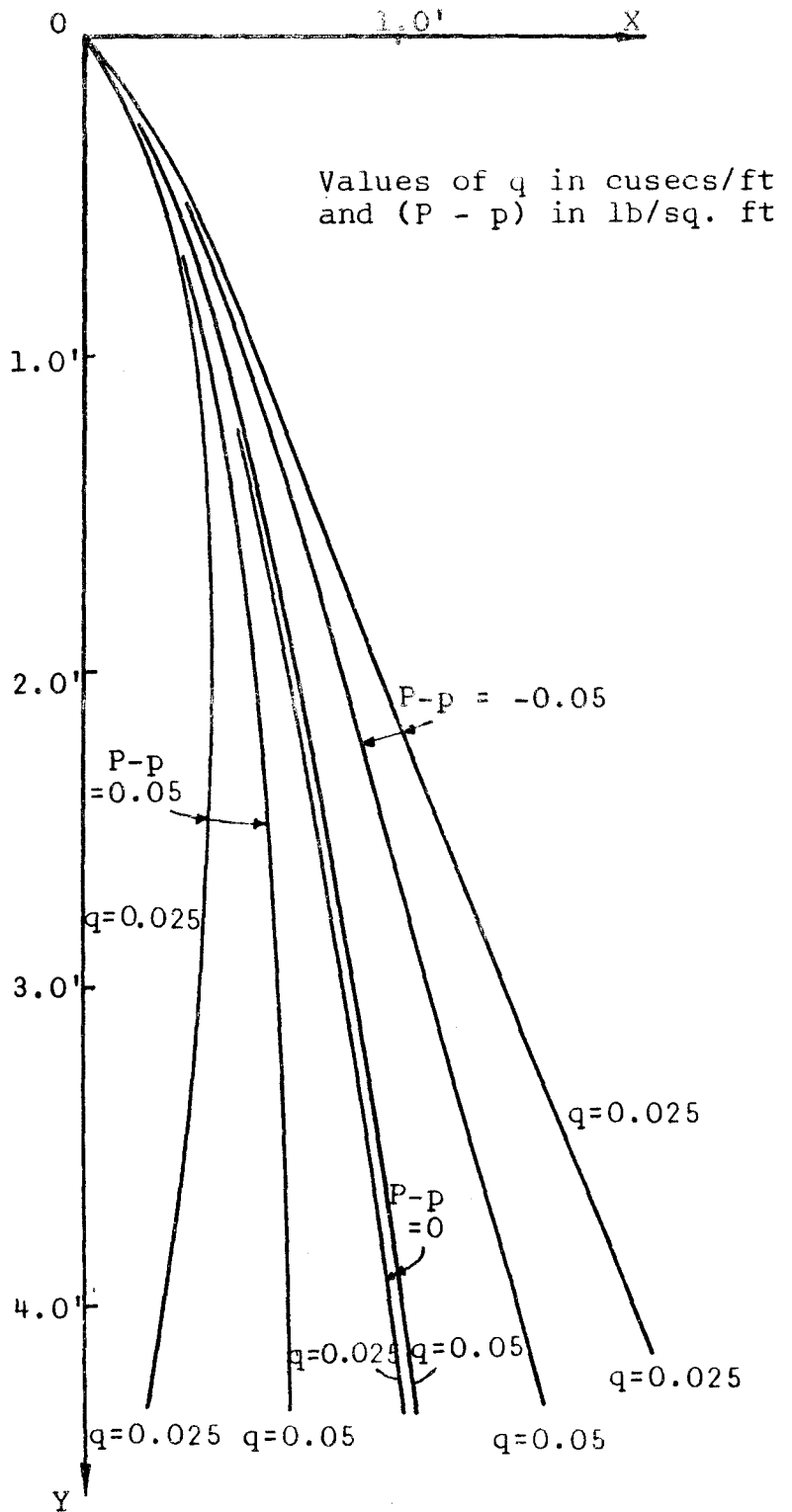

FIGURE 2.3

EFFECT ON TYPICAL TRAJECTORIES OF
DOUBLING THE UNIT DISCHARGE

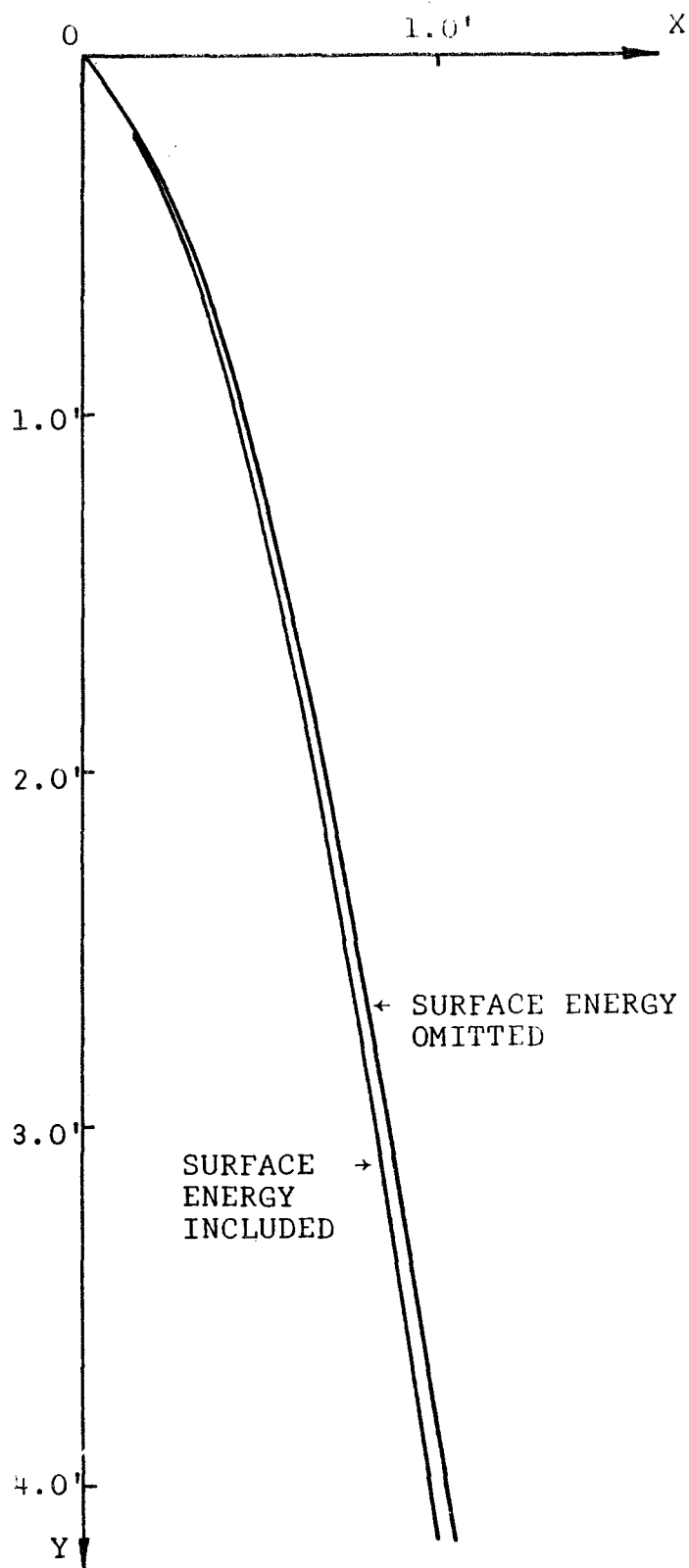

FIGURE 2.4

EFFECT ON STANDARD TRAJECTORY OF
 ELIMINATING SURFACE ENERGY FROM THE
 GOVERNING EQUATION

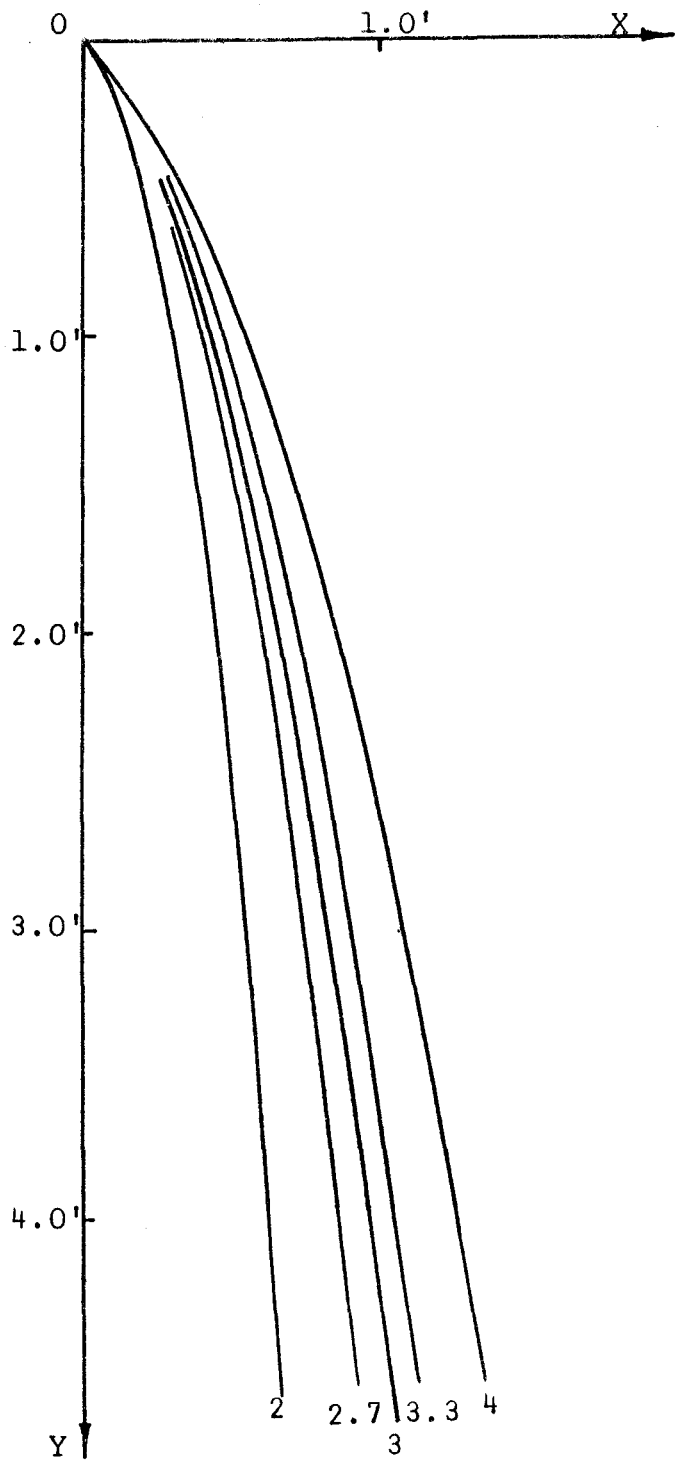

FIGURE 2.5
 TRAJECTORIES FOR FIXED UNIT DISCHARGE AT
 VARIOUS VALUES OF INITIAL VELOCITY, v_0

his supervision by civil engineering undergraduates at the University of Cape Town. Experimental evidence was adduced for verification of the writer's analytical solution, because Kilner stated that certain numerical comparisons with the theory were possible and produced a graph which showed reasonably good agreement with the theory.

Kilner's figures are reproduced as figures 2.6 and 2.7. Figure 2.6 represents the differential pressure plotted against nappe deflection 2 ft below crest level for experimental unit discharges of 0.07 and 0.129 cusecs and for theoretical unit discharges of 0.025 and 0.05 cusecs. It should be mentioned that the height difference between crest level and the lip was not taken into account by Kilner but this distance is in point of fact only a small percentage of the total height of fall and can safely be neglected. Figure 2.7 shows the "stiffness modulus" defined by Kilner as "the pressure differential per unit horizontal deflection at the chosen reference level" based on the positive values in Figure 2.6. It is evident from Figure 2.7 that the theoretical calculations and his experimental evidence are in reasonable agreement.

2.10 General solution for steady pressures

Subsequent to the foregoing presentation of the numerical solution the writer went on to recast the equations of motion in an attempt to find an analytical solution.

ALL DEFLECTIONS
MEASURED AT LE-
VEL 24 INCHES
BELOW WEIR CREST

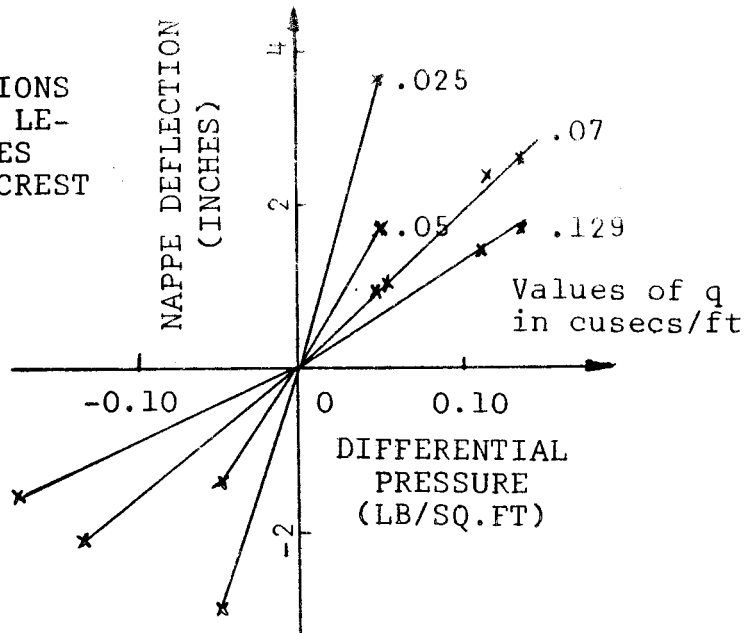

FIGURE 2.6

DEFLECTION VERSUS PRESSURE
DIAGRAM (AFTER KILNER)

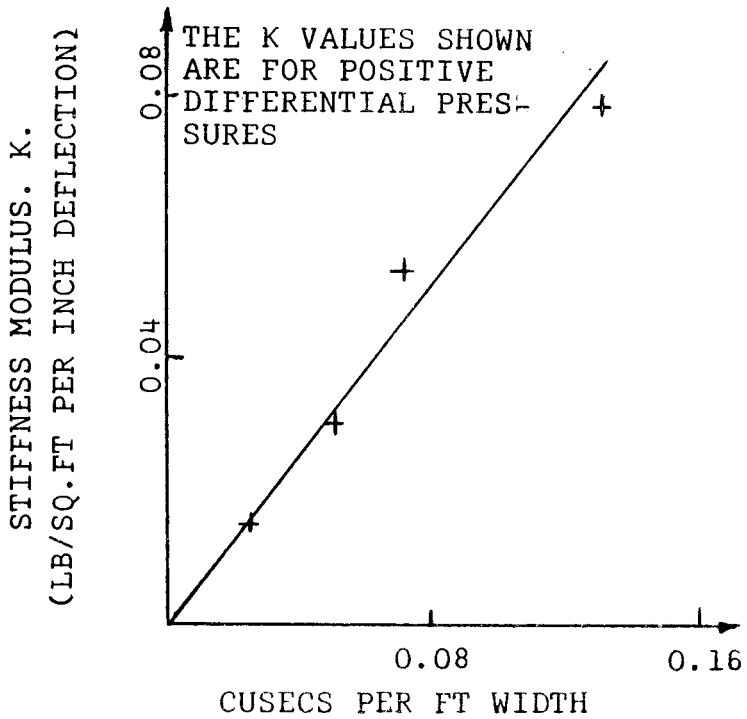

FIGURE 2.7

DIAGRAM SHOWING VARIATION OF
'STIFFNESS MODULUS' WITH UNIT
DISCHARGE (AFTER KILNER)

Since it had been established that the influence of surface energy was indeed negligible it became possible to extend the work of Woronetz¹⁹ (1954), who had developed a solution for horizontal projection, to the less restricted case of projection at any other angle.

The differential equation formulated by the writer was solved by a colleague, L.P. Nutt, and a joint paper²⁸ on the solution was published by the American Society of Civil Engineers in July, 1963.

In this analysis the y-axis is horizontal and the x-axis vertical. The final equations, in nondimensional form, can be written as follows:-

$$\frac{x}{h_0} = \frac{c \sin \theta_0}{a \sin \alpha} \{ \cos \alpha - \cos \left(\frac{V_0 a t}{c h_0} + \alpha \right) \}$$

and
$$\frac{y}{h_0} = - \frac{V_0 t}{a h_0} - \frac{c \sin \theta_0}{a \sin \alpha} \left\{ \sin \left(\frac{V_0 a t}{c h_0} + \alpha \right) - \sin \alpha \right\}$$

where
$$a = \frac{P-p}{\gamma h_0}, \quad c = \frac{V_0^2}{g h_0} \quad \text{and}$$

$$\alpha = \arctan \left\{ \frac{a \sin \theta_0}{a \cos \theta_0 + 1} \right\}$$

The general solution confirmed the accuracy of the earlier numerical solution and a comparison of results obtained from the two methods is presented in Figure 2.8 in which the lines denote trajectories yielded by numerical analysis and the dots represent check determinations by the analytical solution.

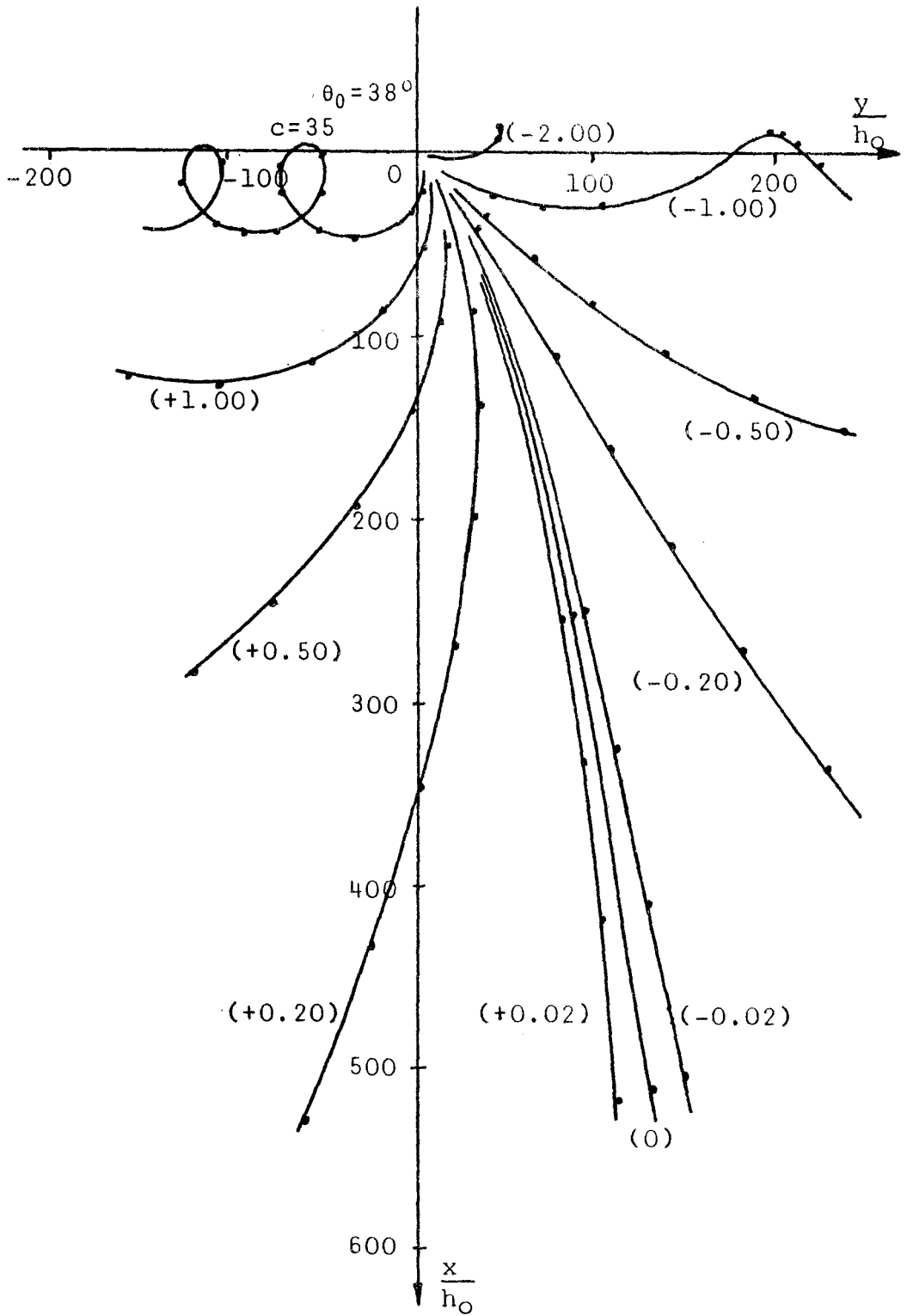

FIGURE 2.8

NAPPE TRAJECTORIES FOR VARIOUS
 VALUES OF TRANSVERSE PRESSURE
 FACTOR 'a'

It should be noted that in the numerical analysis increments of 0.01 ft were used for a nappe 0.008 ft thick at the origin and that the results were then converted to non-dimensional form.

It should also be noted that for zero pressure difference the equations become indeterminate so that for the trajectory marked zero small finite values were in fact employed.

2.11 Comment on solution for steady pressures

The work done on the simple case of steady pressure revealed quite clearly the following facts:

- a) that except for extremely thin nappes the part played by surface energy forces could safely be ignored (although it should not be forgotten that the continuity of the nappe depends on surface tension), and
- b) that the trajectory of a relatively thin sheet of water is extremely sensitive to difference of pressure across the nappe.

It was considered that establishment of these facts in a quantitative manner had constituted an advance in the understanding of the problem of nappe oscillation and that the next logical step would be to extend the analysis to the much more complex problem of determining the effects of harmonic differential pressures as an approximation to

the somewhat irregular but distinctly periodic pressure records taken by Petrikat⁶. The analysis developed is described in some detail in the next chapter.

With respect to conclusion (a) above it should be noted that Petrikat had investigated the effects of surface tension experimentally by introducing ether into the overflowing water. The result was that vibrations were eliminated. However, according to Leo¹¹, cessation of oscillation resulted from the fact that the jet had become roughened and had disintegrated.

Leo concluded that a smooth jet was required for vibrations to develop but that the possibility that surface tensions constituted the restoring forces which control frequency of oscillation did not necessarily follow.

In September 1965 Dr. G.N. Lance visited South Africa and drew to the author's attention a paper²⁹ on a two-dimensional nappe written by him in 1955. In his paper differential analyser solutions of the governing equations were given for certain typical cases.

III. THE EFFECTS OF HARMONIC PRESSURE ON FALLING SHEETS OF WATER

3.1 Extension of analysis for steady pressures

The effects of harmonic pressure could not be determined directly by any known mathematical process so it was decided to extend the analysis of the effects of steady pressure differentials in the knowledge that the solution could at best be an approximation to the truth but might nevertheless yield valuable information.

In contrast to the steady flow situation it was found that a rapidly varying pressure causes a falling sheet of water to take up a sinuous profile which varies from instant to instant within a certain fixed "spread" on either side of the trajectory associated with zero pressure difference across the faces of a nappe. The analysis described in this chapter was submitted in December 1962 to the London Institution of Civil Engineers in a paper³⁰ which was published in the Proceedings of the Society in July 1964.

3.2 Development of differential equation for nappe element subjected to harmonic pressure differentials

The development of the differential equation follows that described in Chapter II with the exception that the pressure factor α is re-defined as

$$\alpha = \frac{F + P \cos(\omega t)b}{Q V_0} \quad \dots \quad 3.1$$

where F is any steady pressure and $P \cos (\omega t)$ is a pressure which varies cosinusoidally with time, t , and has peak minimum and maximum values, P .

3.3 Establishment of the nappe form

The equation previously developed then assumes the following form with α defined as in equation 3.1:-

$$y'' \left\{ \rho \left(1 + \frac{Y}{\lambda} \right)^{\frac{1}{2}} - \beta \right\} = (1 + y'^2)^{3/2} \left\{ \alpha + \frac{\rho}{2\lambda \left(1 + \frac{Y}{\lambda} \right)^{\frac{1}{2}} (1 + y'^2)^{\frac{1}{2}}} \right\}$$

..... 3.2

This second order, nonlinear, differential equation describes the motion of a nappe element that is projected from the origin under certain conditions and thereafter is acted upon only by the force of gravity, transverse pressure and surface energy. Using the equation successive traces for elements that depart under different initial conditions of pressure and rate of change of pressure can be computed by numerical analysis.

To determine the approximate form of the nappe at any particular instant it was found expedient to make certain simplifying assumptions that were known to be not strictly valid. For instance, it was assumed that the applied pressure acted in a direction normal to the path of the trajectory of each element whereas this would be true only for nappe elements of the extreme traces. Similarly, except at the extreme traces the resultant of the tangential surface

energy forces would not act normally to the trace as implied in the development of the equation. The nappe shape at any given instant can be approximated by plotting traces of particles leaving at selected intervals and joining appropriate computed points; unless the form of the nappe is inordinately tortuous it is believed that the effects of the simplifying assumptions are of secondary importance and that the analysis gives a fairly good representation of the nappe profile at any selected instant.

3.4 Numerical solution

Typical nappe traces were determined on the IBM 1620 electronic computer at this University using the numerical method of analysis described in Chapter II with lengths of incremental arc of 0.01 ft or less. The FORTRAN program developed for the solution is reproduced in Appendix II.

3.5 Check on cumulative errors

Because of the inherent difficulty of establishing the magnitude of possible error implicit in iterative methods of solution, a special computer program was devised for finding the path of a discrete particle using a numerical technique similar to that used for the nappe; the results for various values of increment were then compared with known exact values and the trajectories yielded are depicted on Figure 3.1.

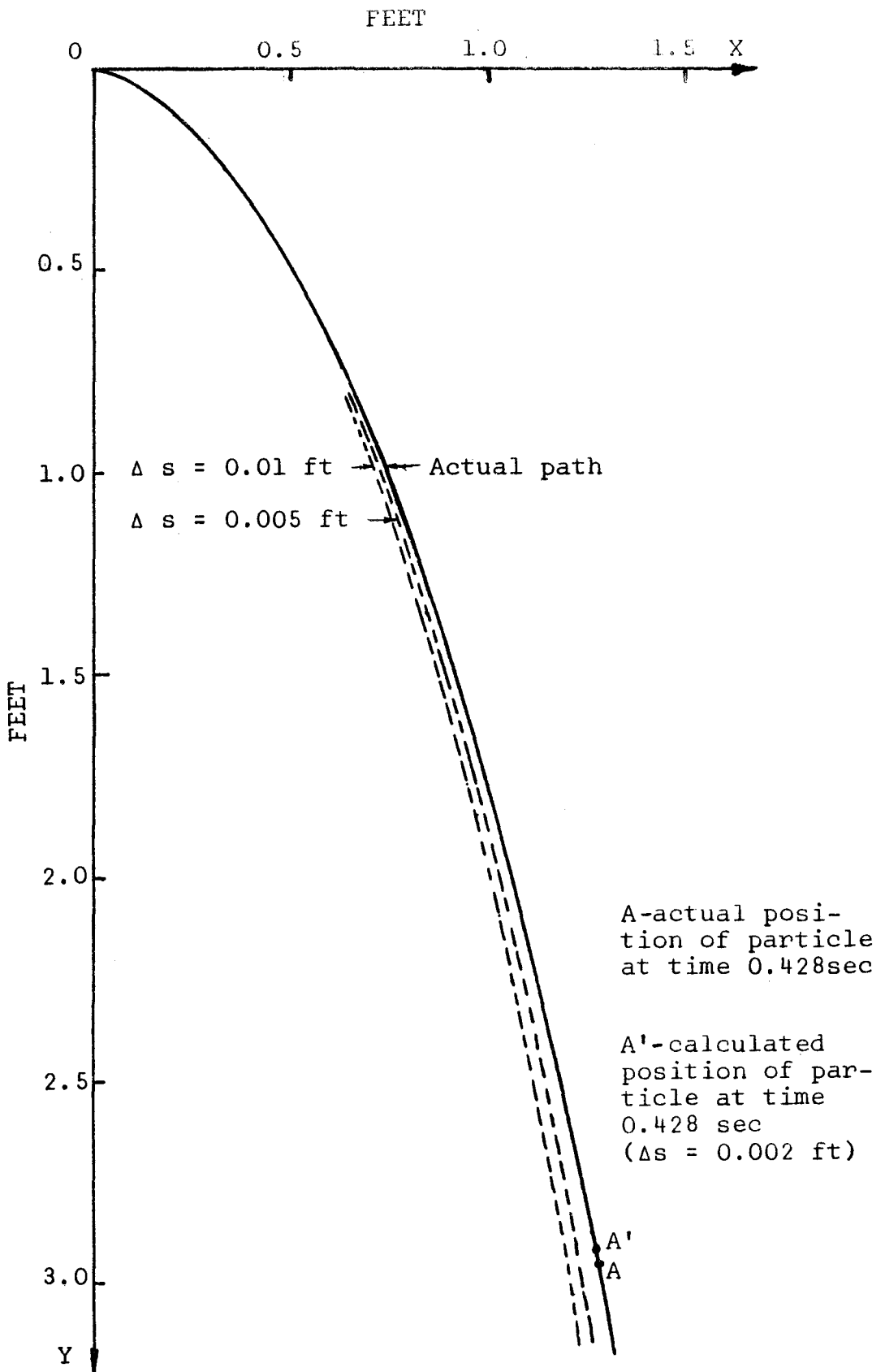

FIGURE 3.1

COMPARISON OF TRAJECTORIES FOR DISCRETE PARTICLE (AS CALCULATED BY NUMERICAL ANALYSIS) WITH EXACT SOLUTION

It will be seen that errors are not inappreciable for an incremental arc of 0.01 ft but that accuracy can be improved as desired by reducing the size of increment. With the Model I computer the time required to trace a $4\frac{1}{2}$ ft long trajectory in increments of 0.002 ft was about 80 minutes but only 20 minutes for increments of 0.01 ft.

To check the error involved with rapidly varying pressures some trajectories were computed in increments of both 0.005 and 0.01 ft. It was found that the maximum difference in x-coordinate was negligible and it would thus appear that the accuracy of the numerical analysis is greater for rapidly fluctuating pressures than for steady pressure where errors would tend to be cumulative. Indications were that for rapidly fluctuating pressure the method adopted gave reasonably satisfactory results provided the increment did not exceed about 0.02 ft.

In November 1964 an IBM Model II computer with high speed printing facilities became available at this University and a check on the accuracy of the numerical solution was made using an increment of only 0.001 ft. Although improved accuracy was thereby achieved the changes necessary to correct the earlier profiles were insignificant. For example in $3\frac{1}{2}$ ft of fall the more accurate position of a particle was 0.025 ft lower than, and had a lateral displacement of less than 0.015 ft from the position previously computed with an increment of 0.01 ft.

3.6 Compilation of computer program

To save machine time the instructions given in the program were such that except for values near the origin only every tenth set of computed values was typed out. At each selected printing interval the following data were tabulated:-

- a) x and y coordinates
- b) Radius of curvature R
- c) Angle ϕ
- d) Velocity V
- e) Time t
- f) Volume of space between nappe and y-plane

Some flexibility was introduced into the program to permit control of certain parameters by use of selector switches which could be reset at any desired stage of computation.

3.7 Typical results and nappe profiles

Typical trajectories are presented in this section to illustrate some of the more important findings.

In the computations certain "standard" values were chosen to accord with measurements on model spillways in the hydraulic laboratory at which nappe oscillations were known to have occurred. The discharge per foot width of crest was taken as 0.025 cusec and the angle and velocity of projection

were fixed at 38° below the horizontal and 3.00 ft/sec respectively. For these trajectories the steady pressure, F , was equated to zero and the variation of pressure difference was thus as shown in Figure 3.2.

Contrary to expectation and indicative of the fallaciousness of Pariset's "garden hose" analogy, it was found that the trajectory of particles leaving when pressure difference was a maximum (+P) followed a slightly oscillating path close to the trajectory appropriate to zero pressure difference; similarly, the trajectory of elements departing when pressure difference was a minimum (-P) intertwined with the previous trajectory as shown in full lines on Figure 3.3. The trajectory of elements which departed when the pressure was zero (shown dotted) lay well outside the other trajectories (except, significantly, near the origin) and for a given value of peak pressure, the spread was found to increase as frequency was reduced.

Typical traces with appropriate points joined to depict the nappe profile at selected instants of time are shown in figures 3.4 and 3.5. Figure 3.6 is an enlarged detail of Figure 3.4 to illustrate clearly the trajectories near the origin.

3.8 Comment on results

A study of typical nappe profiles revealed that a sinusoidal pressure variation, with $P = 0.5$ lb/sq. ft. and

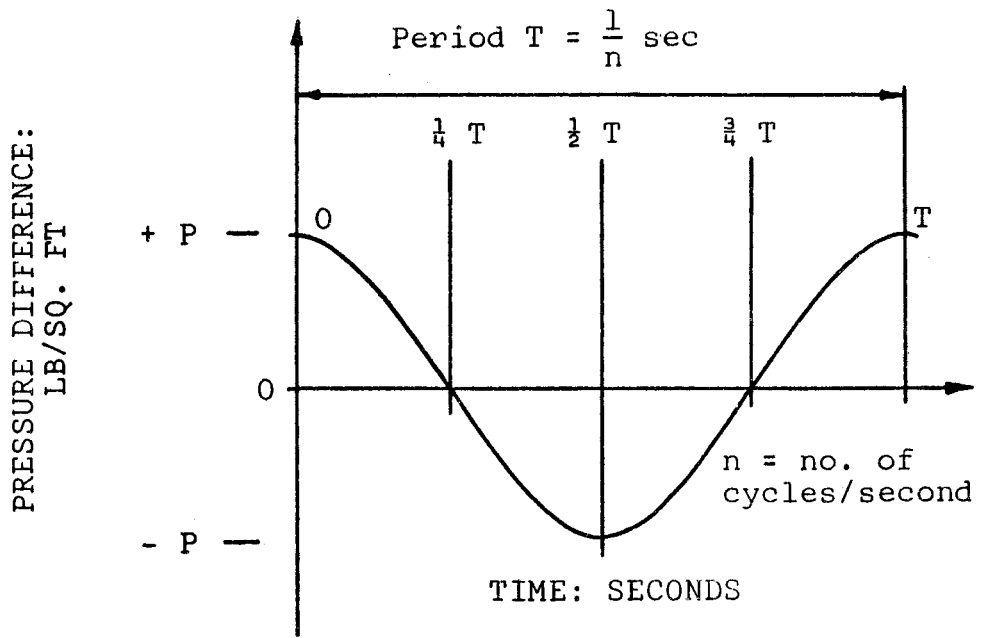
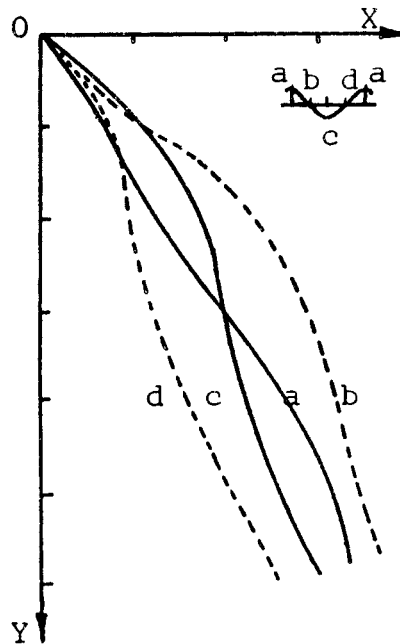

FIGURE 3.2
APPLIED PRESSURE



- (a) Path of elements leaving at time zero, time T , or integral multiples thereof
- (b) Path of elements leaving at time $\frac{1}{4}T, 1\frac{1}{4}T, 2\frac{1}{4}T, \dots$
- (c) Path of elements leaving at time $\frac{3}{4}T, 1\frac{3}{4}T, 2\frac{3}{4}T, \dots$
- (d) Path of elements leaving at time $\frac{1}{2}T, 1\frac{1}{2}T, 2\frac{1}{2}T, \dots$

FIGURE 3.3
TRAJECTORIES OF ELEMENTS

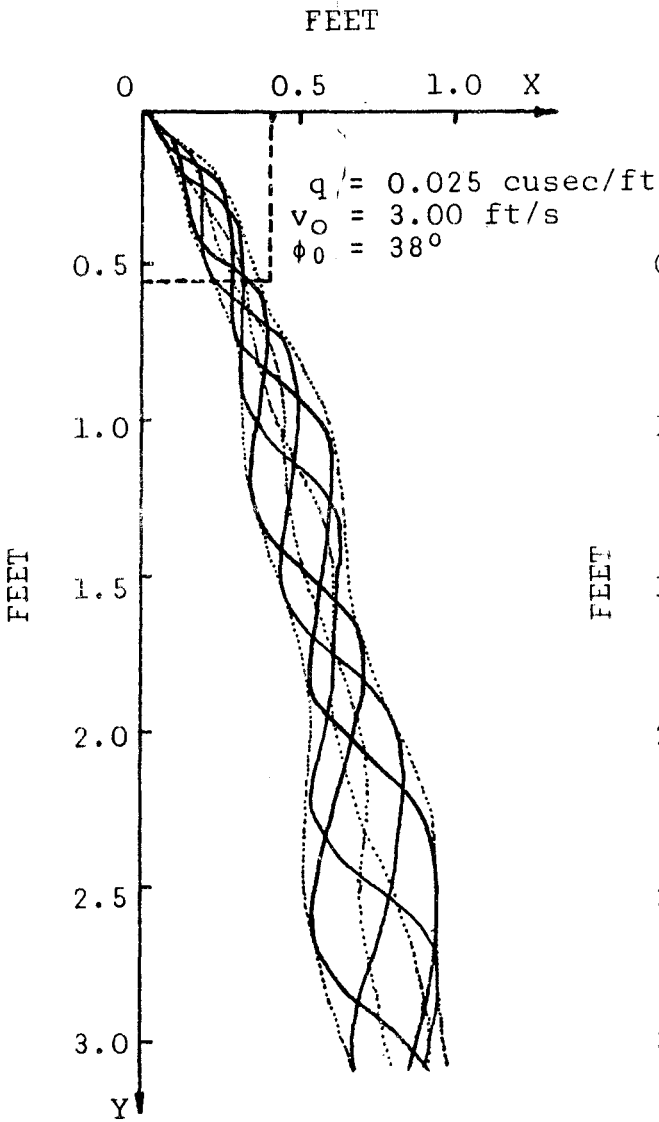

FIGURE 3.4

TRAJECTORIES AND NAPPE
 PROFILES FOR 8 C/SEC

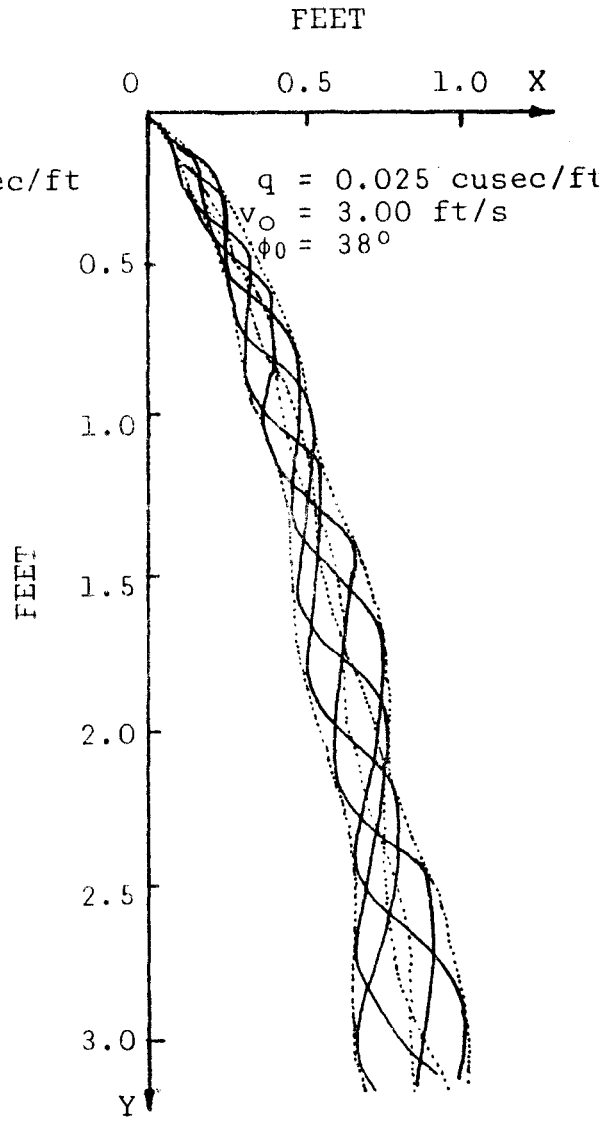

FIGURE 3.5

TRAJECTORIES AND NAPPE
 PROFILES FOR 10 C/SEC

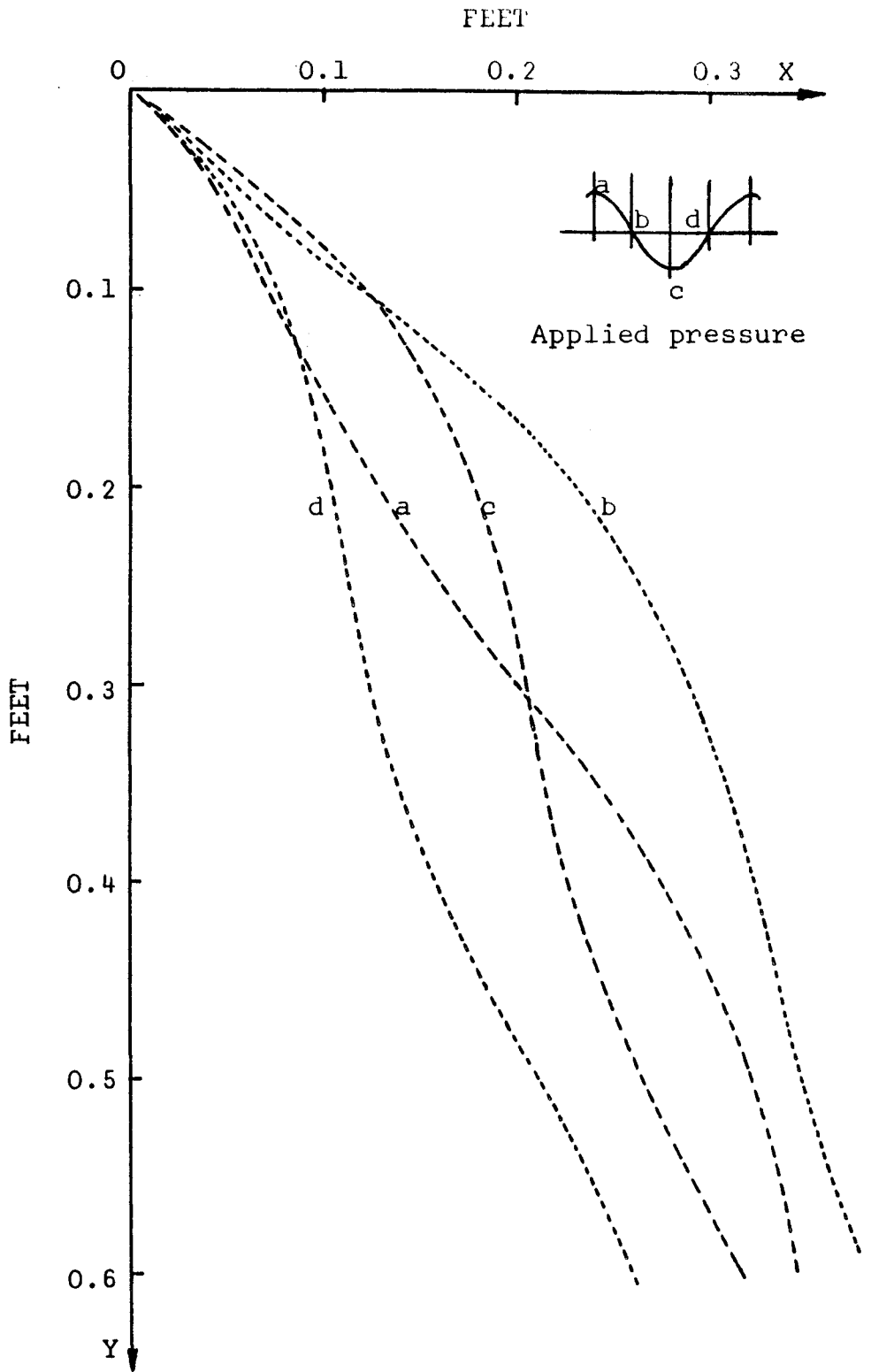

FIGURE 3.6

ENLARGED DETAIL OF TRAJECTORIES NEAR
ORIGIN FOR 8 C/SEC

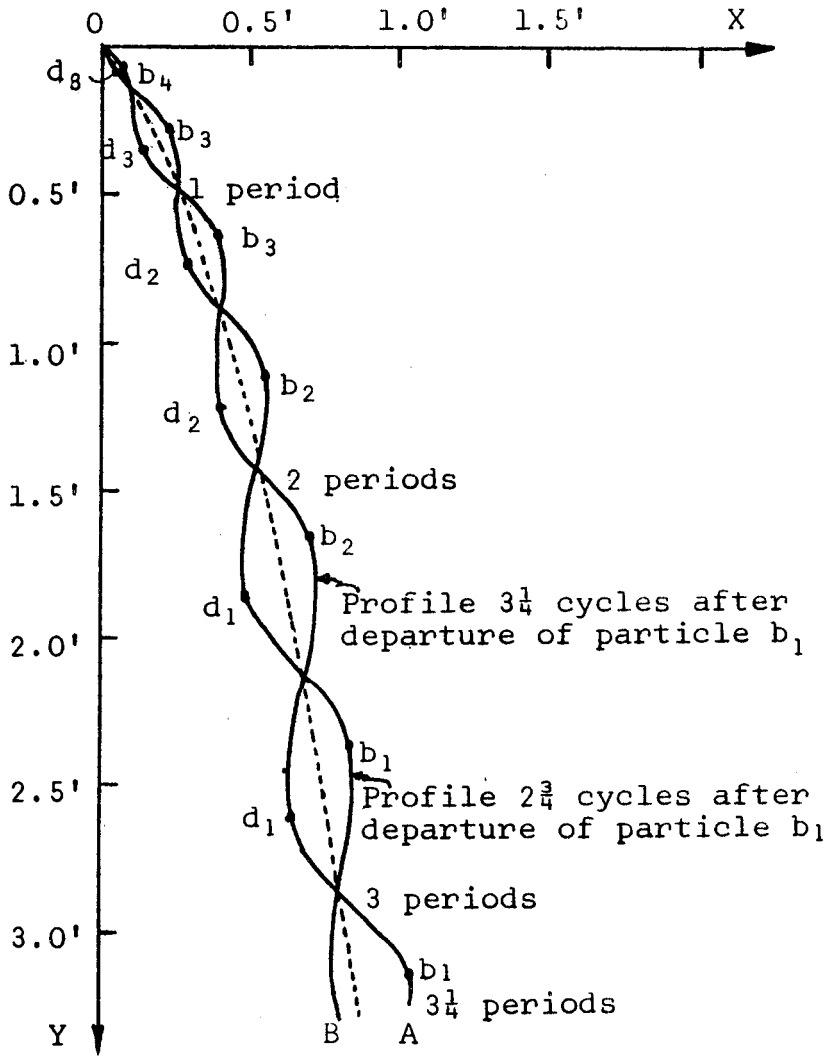
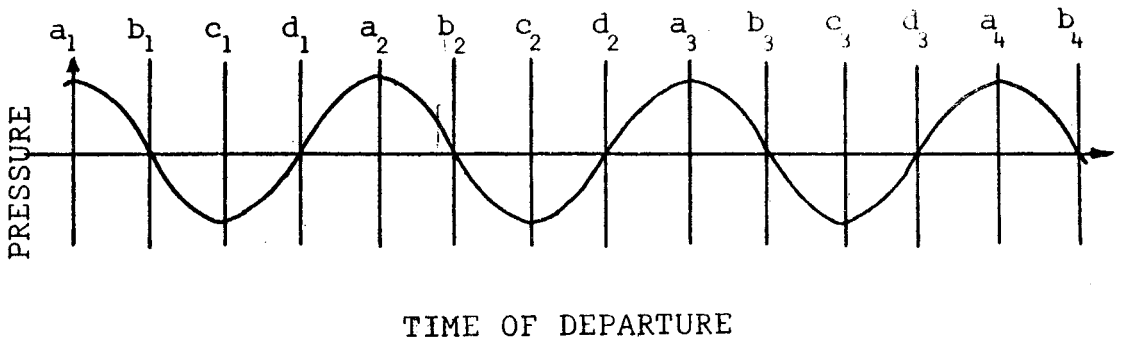

FIGURE 3.7
CALCULATED NAPPE PROFILES

frequency 8 cycles per second, would generate a peak volume change between the nappe and the vertical plane of about ten percent of atmospheric pressure (i.e. 10 percent of about 1,750 lb/sq. ft.). In an attempt to explain this incompatibility with the almost insignificant experimental values of pressure the author was led to the realization that the number of periods in an oscillating nappe must be approximately equal to an integer plus one quarter. The indication is that the nappe is automatically in a state of resonance and the wide implications of the mathematical solution are described in Chapter IV and V. For further clarification of the analysis an arbitrary set of results is shown in Figure 3.7 which illustrates the positions of particles leaving at different times of a sinusoidal pressure variation at two selected intervals within a cycle.

IV. THE 'K + $\frac{1}{4}$ ' CRITERION

4.1 Ratio of possible frequencies

The key to deeper understanding of the mechanism of nappe oscillation came in the realization that if the time taken for redistribution of pressure was neglected the number of wave-lengths contained in an oscillating nappe could only be an integer plus one-quarter.

It followed that the ratio of possible frequencies would be approximately

$$\begin{array}{cccccc} 1\frac{1}{4} & : & 2\frac{1}{4} & : & 3\frac{1}{4} & : & 4\frac{1}{4} & : & 5\frac{1}{4} & \dots \\ \text{or} & & 5 & : & 9 & : & 13 & : & 17 & : & 21 & \dots \end{array}$$

and this contention was checked against a set of experimental results that had previously been obtained in undergraduate studies conducted under the direction of the author.

4.2 Comparison of theory with nappe oscillation frequencies determined by Kemp and Pullen

Table 4.1 shows a set of recorded nappe oscillation frequencies observed in a model in the civil engineering laboratory by Kemp and Pullen¹⁴.

The frequencies were determined on the model in the 6 ft wide flume shown in Figure 1.2 with the aid of a General Radio stroboscope (Type 1531-A) which, when in adjustment, gives results to an accuracy of about one percent.

Table 4.1 - Nappe oscillation frequencies determined
experimentally by Kemp and Pullen

Head on crest: ft	Height of fall: in.	Frequency in cycles per minute (values in parentheses are the measured frequencies reduced by a scale factor)		
		Range 1	Range 2	Range 3
0.041	37.2	350 (8.8)	515 (12.9)	678 (17.0)
	38.7		498 (12.9)	656 (17.0)
	40.7		481 (12.9)	635 (17.0)
	41.7		471 (12.9)	623 (17.0)
	42.7		462 (12.9)	611 (17.0)
0.046	37.2	344 (8.9)	518 (13.1)	674 (17.0)
	38.7		504 (13.0)	
	42.4		470 (12.9)	621 (17.0)
	45.0		450 (12.9)	592 (17.0)
0.056	36.4	360 (9.0)	521 (13.0)	
	37.2	361 (9.0)	527 (13.1)	684 (17.0)
	38.7		513 (12.8)	684 (17.0)
	42.7		475 (13.0)	621 (17.0)
	45.0		462 (13.0)	605 (17.0)
0.064	36.4	376 (9.2)	529 (13.0)	
	37.2	370 (9.1)	528 (13.0)	
	45.0		470 (12.9)	618 (17.0)
0.071	36.4	372 (9.0)	535 (13.0)	
	45.0		480 (13.0)	630 (17.0)

Data selected are those where two or more frequencies were measured for given initial conditions.

The ratio of frequencies can be deduced from the figures given in parentheses where in each instance the highest (or higher) frequency has been taken as a whole number. It is evident that the ratios accord remarkably well with those predicted by the integer-plus-one-quarter theory proposed in Section 4.1. These findings were published³¹ in the Transactions of the South African Institution of Civil Engineers in September 1963.

4.3 Comments on 'K + $\frac{1}{4}$ ' criterion

The excellent correlation between the values predicted and those measured demonstrated that both Petrikat⁵ and Pariset⁴ were correct in their assumption that the air in the space beneath the nappe acted as a link in the "feed-back" mechanism and that theories such as those based on the physics of organ pipes and surface tension effects could justifiably be discarded.

The experimental verification of the 'K + $\frac{1}{4}$ ' criterion establishes the fact that the "feed-back" sustains continuous steady oscillation by virtue of the time-delay of responses to departures of the system from its equilibrium state. The phenomenon exhibited is one of self-excitation where the nappe is automatically in a resonant state.

Certain experimental observations can now be readily explained and further implications of the ' $K + \frac{1}{4}$ ' criterion are discussed in this and in succeeding chapters.

4.4 Prediction of actual frequencies

Since the time taken for a particle (projected at given velocity and in a given direction) to fall from weir lip to apron or tail-water can readily be ascertained and since the number of wave lengths is constrained to be an integer plus one-quarter, it follows that a range of possible frequencies can be determined.

If V_0 represents the velocity of the water leaving the weir lip and V_{0y} the component of velocity in the vertical direction then the frequency, f , can be calculated from the expression

$$f = \frac{K + \frac{1}{4}}{\frac{V_{0y}}{g} + \left\{ \frac{(V_{0y})^2}{g^2} + \frac{2H}{g} \right\}^{\frac{1}{2}}} \quad \dots \quad 4.1$$

where H is the height of fall from the crest lip to the apron or tail-water, g the gravitational acceleration and K an integer.

The value of V_0 for any given discharge is determined by the shape of the weir and may be found by calculation or from model tests. The thickness of nappe at the point of free discharge on dams raised by stressed cables is

generally only a small fraction of the head of water on the crest.

The question immediately arises as to which particular value of K to adopt and consideration of this matter will be deferred to Chapter V. Generally, however, K lies between 1 and 5 although it may be greater than 5 in certain circumstances.

4.5 Recorded frequencies

Figure 4.1 shows a plot of frequency against height of fall for various values of the integer K . To obtain a set of curves it was found necessary to assume a value of V_{0y} for use in equation 4.1. The value chosen was 2.12 ft/sec which seemed a reasonably realistic value for laboratory models. As the height of fall increases the value of V_{0y} becomes relatively less important so that the curves for $H = 20$ ft or more become virtually independent of the value of V_{0y} .

Recorded frequencies from various sources were superimposed on the lines and these demonstrate the validity of the ' $K + \frac{1}{4}$ ' criterion. It should be noted that many of the frequencies quoted by Pariset are integral numbers of cycles per second and may thus be subject to appreciable error when converted to cycles per minute. Account should be taken also of the fact that in the case

of large dams determination of frequency is relatively difficult.

As can be seen from Figure 4.1, only for falls greater than about 2 ft does the nappe appear to set up spontaneous vibrations unless additional energy is introduced by means of a fan or by wind blowing in an upstream direction.

The pronounced kink in the curves seems to demarcate the height of fall at which oscillations can occur spontaneously. This limitation is possibly attributable to the fact that the rate of change of frequency increases rapidly with decrease in height on the left-hand side of the kinks.

The same data have been replotted to logarithmic scales on Figure 4.2. The fact that the resulting curves are nearly straight indicates that for any given value of K the frequency varies approximately as some power of fall distance. The exponent is one-half which differs from that of one-sixth in the formula derived by Pariset⁴.

4.6 Effect of varying the fall height

Experiments on a model show that if the apron or tail-water is gradually lowered the frequency of nappe oscillation will diminish inversely as the square root of the fall distance. At a particular juncture, however, the

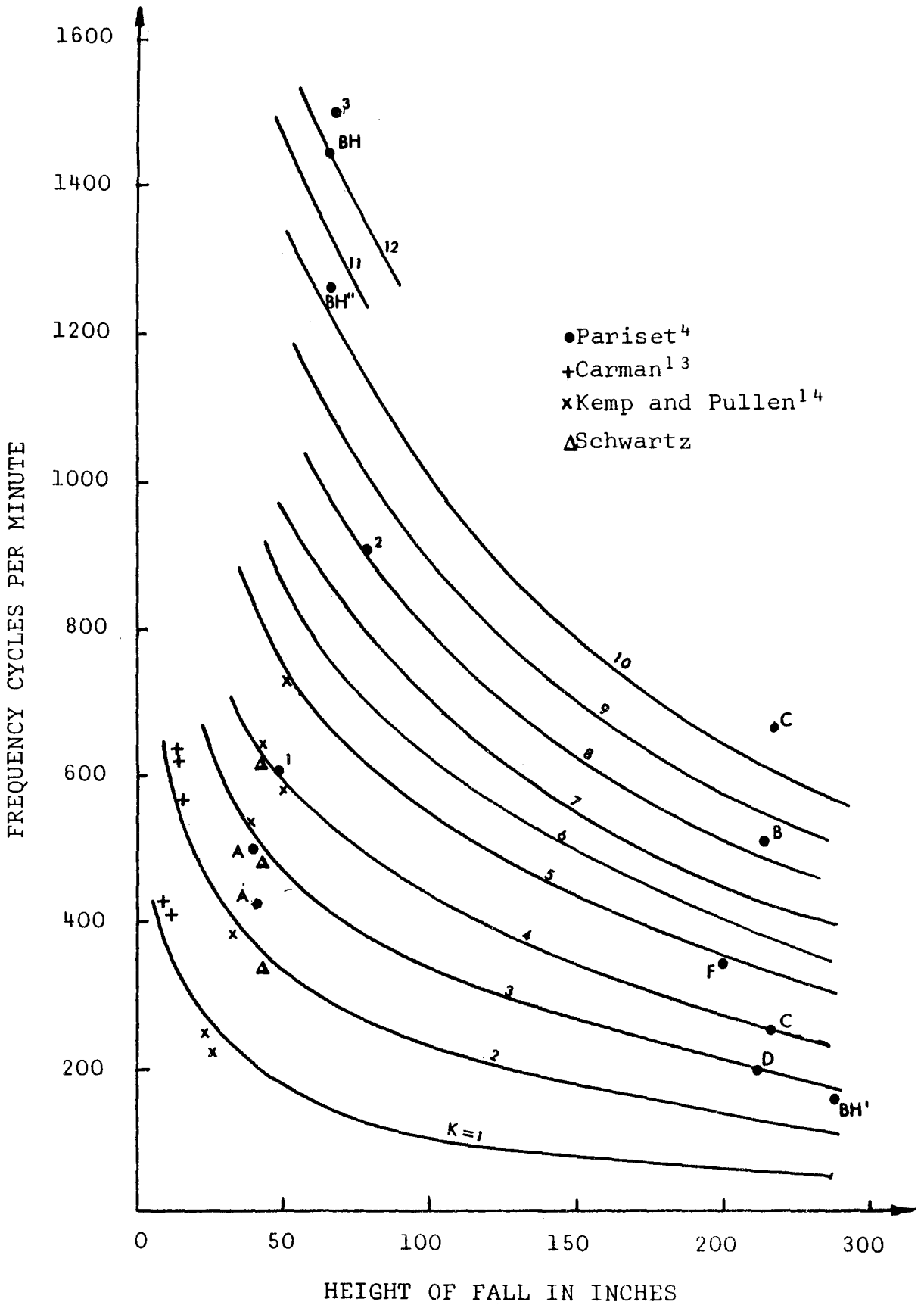

FIGURE 4.1

FREQUENCIES COMPUTED BY USE OF EQUATION 4.1 FOR SUCCESSIVE VALUES OF THE INTEGER K SHOWING OBSERVED DATA FROM SEVERAL SOURCES (NATURAL SCALES)

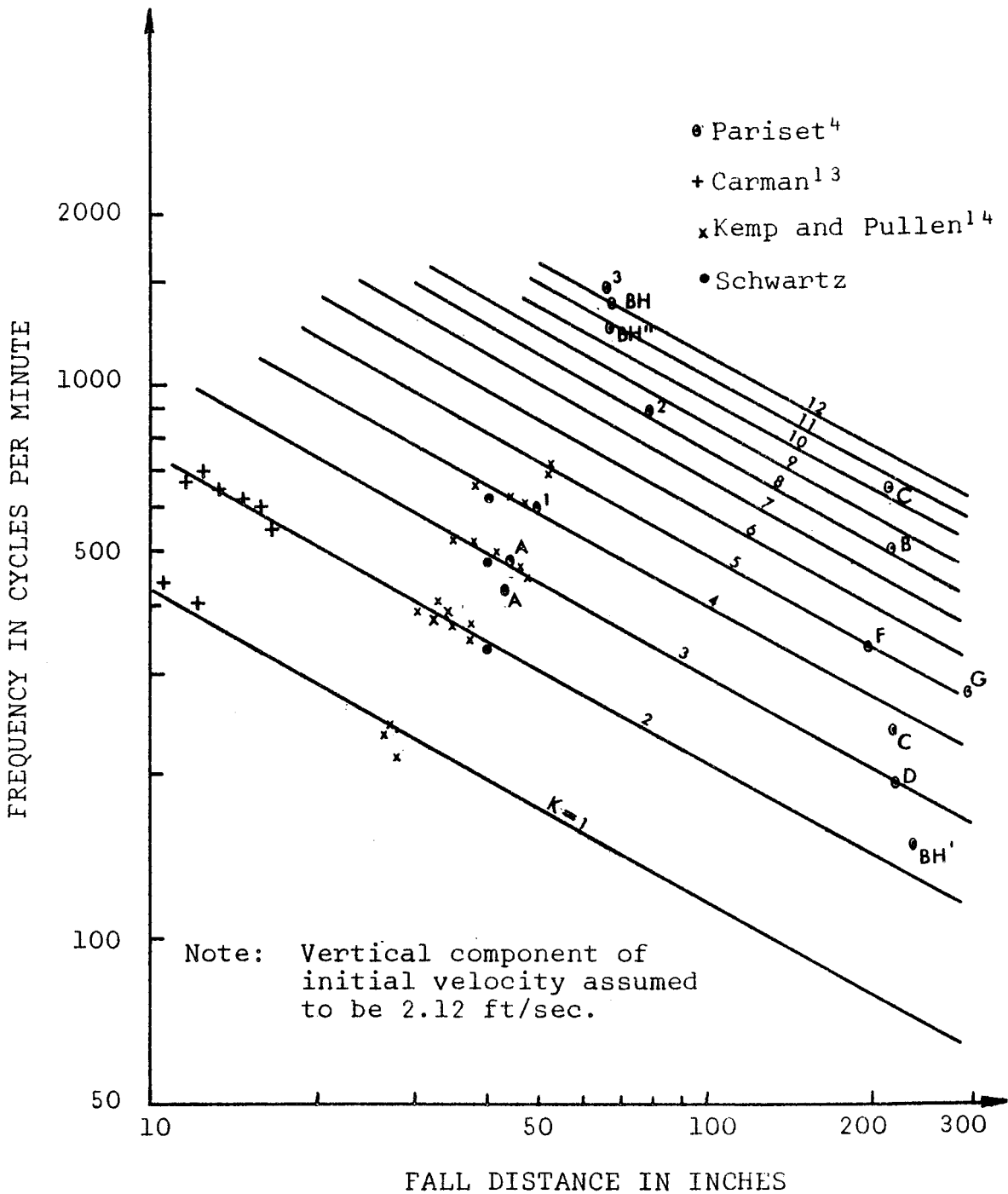

FIGURE 4.2

FREQUENCIES COMPUTED BY USE OF EQUATION 4.1 FOR SUCCESSIVE VALUES OF THE INTEGER K SHOWING OBSERVED DATA FROM SEVERAL SOURCES (LOGARITHMIC SCALES)

frequency will rise suddenly as the next higher value of the integer, K, becomes operative and thereafter the frequency will diminish gradually as before.

If the apron is then gradually raised to decrease the fall the frequency will rise to a value higher than that at which the previous discontinuity occurred whereupon there will be a sudden decrease in frequency to the value appropriate to the original value of K. The cycle which resembles the familiar hysteresis loop is illustrated in Figure 4.3 adapted from the results of experiments carried out by Carman¹³.

The foregoing experimental evidence points to the fact that with variation of fall distance a nappe in oscillation tends to retain an initial existing value of the integer K within a certain band-width.

It should be noted that these experimental findings are in direct conflict with Pariset's published results⁴ which suggest that the frequency rises gradually with increase in fall height. (See Fig 14 of reference 4 and figure 6 of reference 15.)

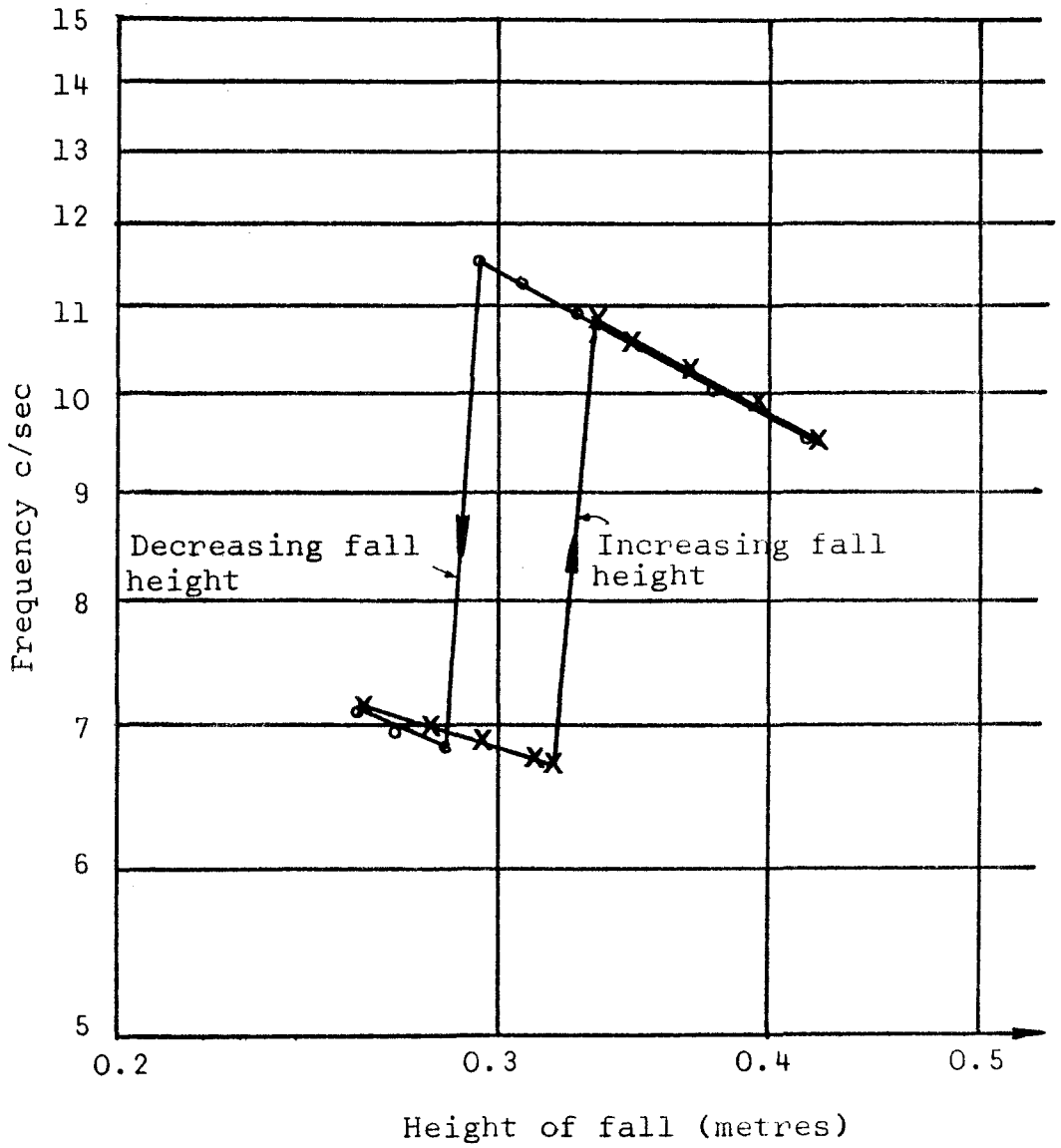

FIGURE 4.3

VARIATION OF FREQUENCY WITH FALL DISTANCE EXHIBITING HYSTERETIC BEHAVIOUR (AFTER CARMAN)

V. THE ENERGY BUDGET

5.1 Energy absorption theory

To gain an even more profound understanding of the basic mechanism of nappe oscillations a study of the inter-relationship between force, displacement and damping was undertaken. Some significant conclusions were reached from examination of the energy absorption characteristics of various portions of a somewhat simplified representation of a typical nappe.

5.2 Effective oscillation of nappe

Only by consideration of the net effect of movement of individual particles can the effective oscillation of the nappe as a whole be described.

In a nappe subject to cosinusoidal pressure variation consider a stage where the pressure in the trapped air is a maximum (position A' in Figure 5.1). If attention is concentrated on the lowermost one and a quarter wave-lengths the situation can, for clarity of development, be simplified if it be imagined that the direction of fall is vertical and that both wave length and amplitude remain constant as shown in Figure 5.2.

From the ' $K + \frac{1}{4}$ ' criterion it is known that the pressure to the left of the nappe will be a maximum when the nappe is in the position indicated by the full line in

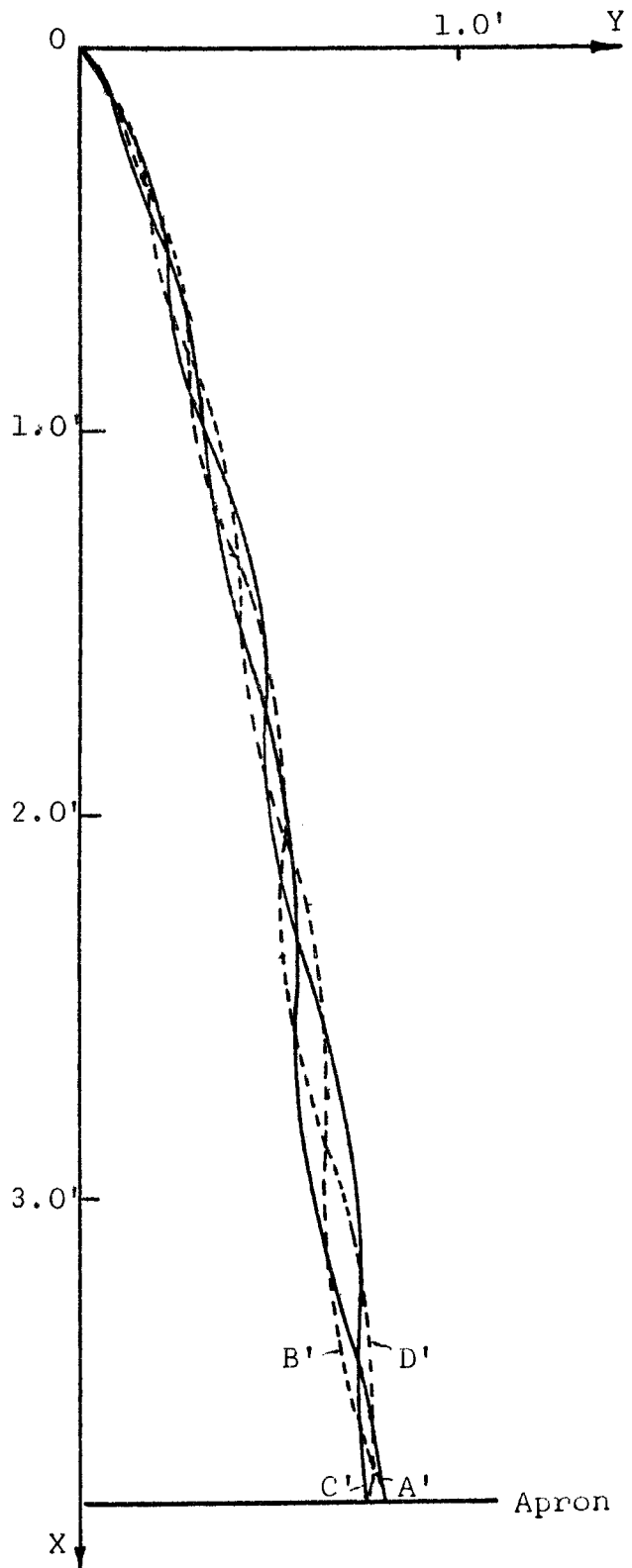

FIGURE 5.1

COMPUTED PROFILES OF TYPICAL NAPPE
 SUBJECT TO SINUSOIDAL PRESSURE
 VARIATION: $f = 454 \text{ C/MIN}$

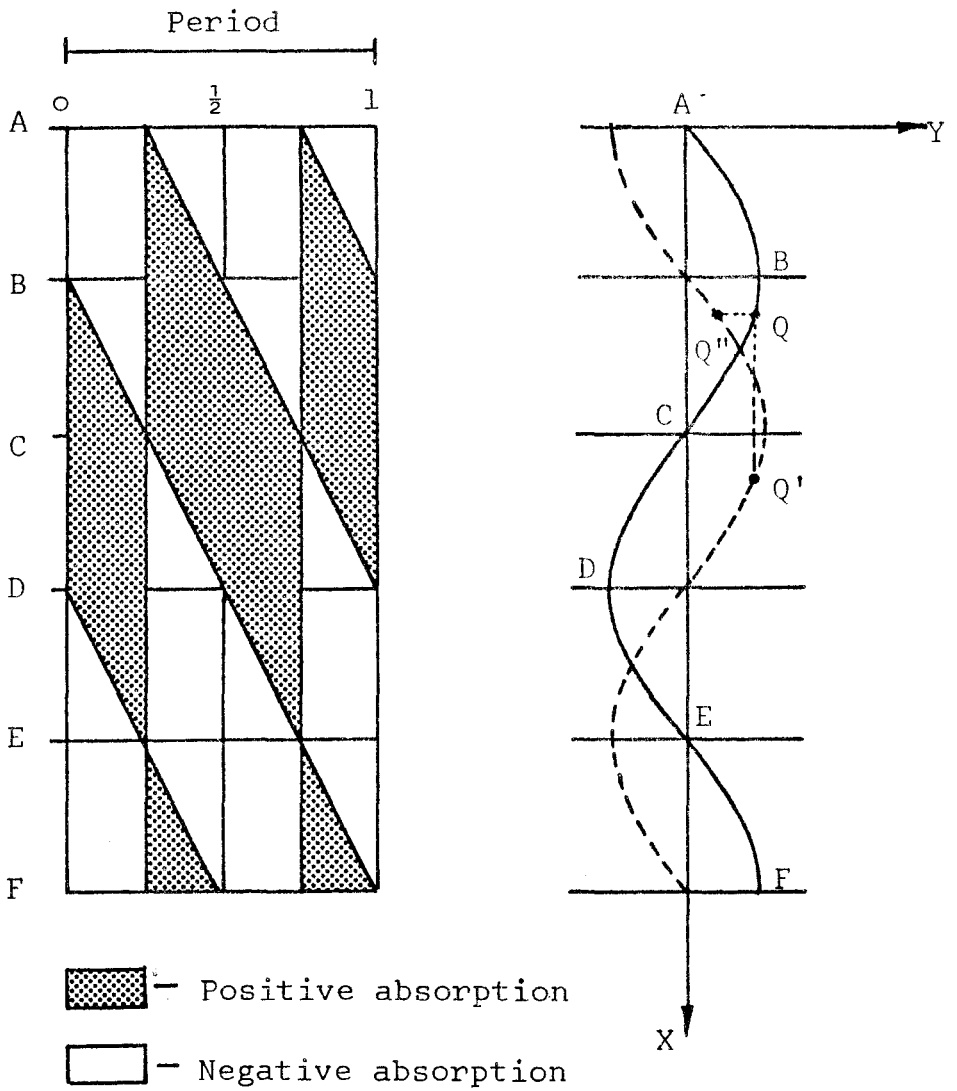

FIGURE 5.2

SIMPLIFIED DIAGRAMMATIC REPRESENTATION
 OF LOWERMOST FIVE QUARTER PERIODS OF
 NAPPE SHOWING PUMPING AND ABSORPTION
 ZONES

Figure 5.2 notwithstanding the fact that it would appear to be a minimum for the simplified case under consideration.

One quarter of a cycle later the nappe will be in the position shown by the dotted line. If for the moment the fact is ignored that each particle travels vertically and it is imagined that a typical particle Q instead of travelling to position Q' travels laterally to position Q" on the dotted line and if similar assumptions are made for all other particles, then it becomes apparent that at each elevation the particles are in effect oscillating to and fro in a horizontal plane. It will be seen that, in effect, some particles move toward the left whilst others move toward the right, the phase relationship differing from particle to particle. If it be imagined that a downward travelling sine wave were being viewed through a series of narrow horizontal slits the movements described could be visualized.

If the effective lateral movement of nappe elements at selected points is examined then the inter-relationship of pressure, lateral displacement and damping (which is assumed to be viscous) can be depicted as in Figure 5.3. It will be seen, for instance, that points A and E are always moving in directions opposing the sinusoidal pressure whilst point C always moves in the direction of the pressure. All other points are at times

moving with the pressure and at other times against the pressure.

Hence it follows that, except for point C, over a full wave length (i.e. the nappe between A and E) the energy absorption is alternately positive and negative and that for the simplified case under consideration the algebraic sum of the absorptions, or work done, over an integral number of cycles is zero. This is illustrated on the left-hand diagram in Figure 5.2 where between A and E the shaded area representing positive absorption equals the unshaded area representing negative absorption.

The additional quarter wave-length (i.e. the nappe between E and F) acts as a pump since, over an integral number of cycles, negative absorption exceeds positive absorption except at elevation F where the overall absorption is zero.

Reverting now to consideration of an actual typical nappe it is evident that, as suggested by Pariset, the lowermost quarter wave-length is an important pumping zone.

The magnitude of the pressure pulse generated near the foot of the nappe is probably reduced considerably because the thin nappe, in moving against the pressure build-up, disintegrates to form characteristic three dimensional jets, similar in shape to the teeth of a rake, spaced at

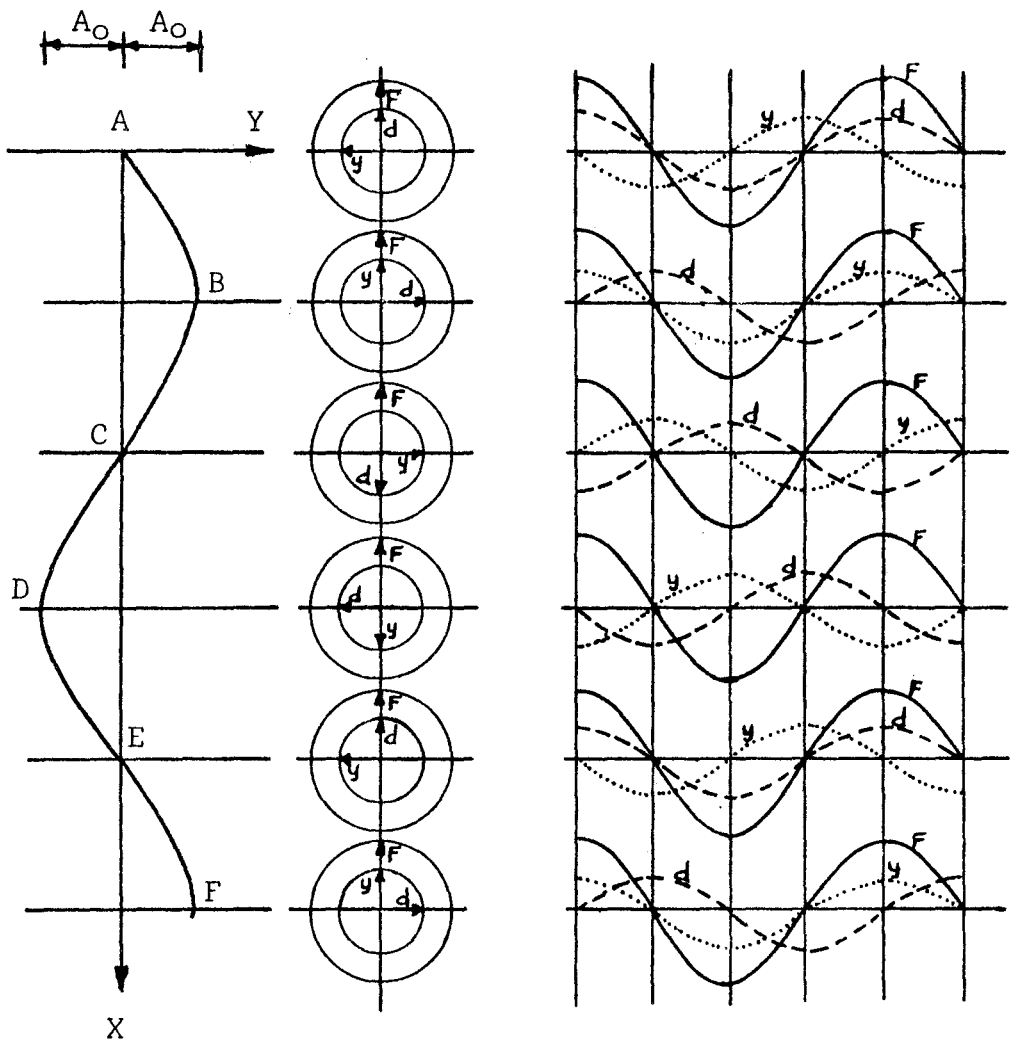

F = driving force
d = damping force
y = displacement

FIGURE 5.3

DIAGRAMMATIC NAPPE SHOWING FORCE,
DISPLACEMENT AND DAMPING
RELATIONSHIPS AT SELECTED ELEVATIONS

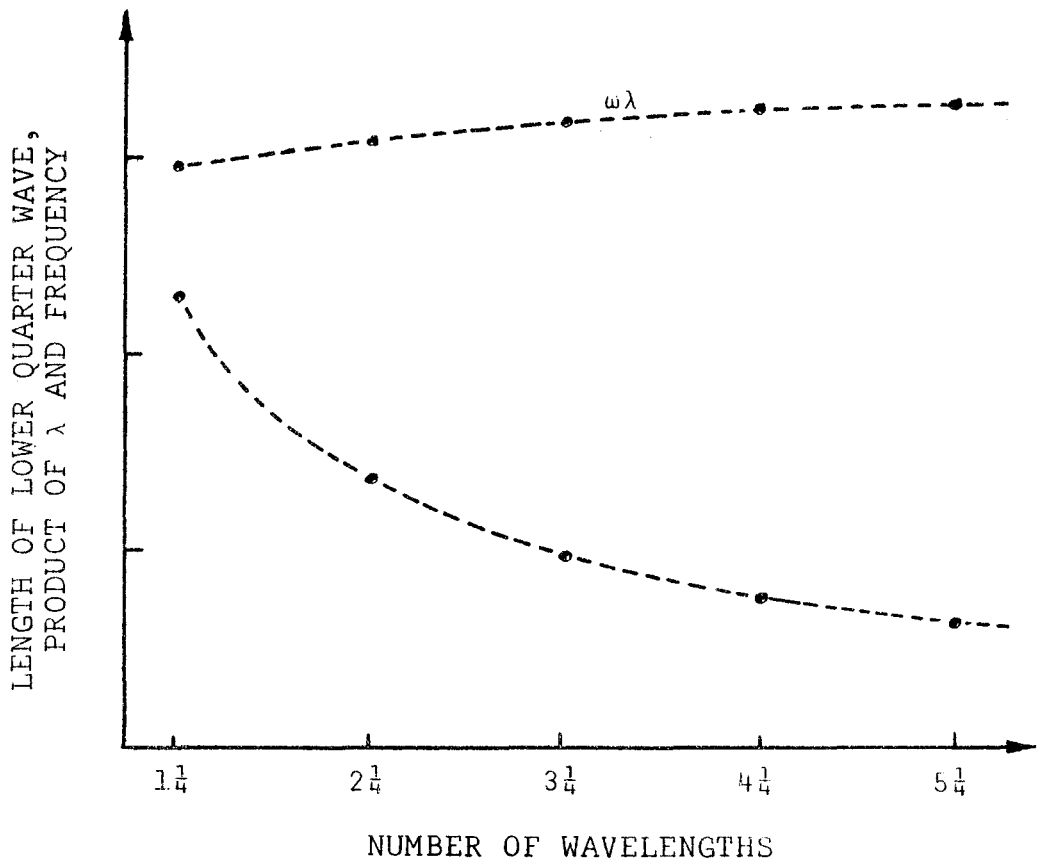

FIGURE 5.4
 TYPICAL COMPUTED VALUES OF FINAL
 QUARTER WAVE-LENGTH AND ITS PRODUCT
 WITH FREQUENCY

regular intervals. When oscillation is initiated the nappe does not break up and so the oscillation builds up rapidly to its sustained maximum amplitude. It is inevitable, too, that whilst traveling behind the nappe to the crest the pressure pulsations generated near the foot of the nappe are modified in magnitude by reflections, amplification and absorption. It should be noted from Figure 5.1 that the absorption areas are attenuated and the pumping areas reduced in size because of the slight waviness of the particle trajectories. Also, the last cross-over point of the A' and C' profiles is not opposite the widest space between the B' and D' curves. Hence the effective length of the lowermost pumping region cannot readily be determined.

Computations for a typical simplified case show that the length of the last quarter wave of the nappe, decreases with increase in the value of K as shown in Figure 5.4, so reducing the effective area of the pumping region. On the other hand, however, the number of pumping strokes per unit of time increases with frequency rise so that the product of λ and the angular frequency, ω , remains approximately constant as shown by the upper line in Figure 5.4.

There exists thus a complex inter-relationship among various factors, some of which can be studied only on an empirical basis. By means of electronic recorders Petrikat has measured pressures beneath and at various distances

from the nappe discharging over an elastic gate. The writer has observed under stroboscopic illumination the behaviour of soap bubbles on the wall beneath the nappe and of soap films in pipes protruding through the nappe. A periodic pressure fluctuation undoubtedly exists but the peak pressures for fixed weirs on models are very small indeed. Nevertheless, these small pressures, acting on large areas, represent appreciable disturbing forces.

On the exterior side of the nappe, energy is radiated into the free air as described by Feather³², and may cause rattling of windows and doors and other troublesome effects even at considerable distances from the source of oscillation.

5.3 Calculations for absorption

- (i) Consider a particle at point A or E on the simplified nappe shown in Figure 5.3

$$\text{Displacement } y = -A_0 \sin(\omega t)$$

where A_0 is the maximum displacement,

ω is the circular frequency of the motion, and

t represents time, which is taken to equal zero

when the nappe is in the position shown on Figure 5.3.

Force exerted on the water element, $F = B \cos(\omega t)$

where B represents the maximum value of the force.

The rate at which work is done on the element by the applied force is given by $F\dot{y}$, which equals

$$-A_0 B \omega \cos^2(\omega t)$$

The work done per period is

$$-A_0 B \omega \int_0^{2\pi/\omega} \cos^2(\omega t) dt$$

and the average rate of work done over a cycle, or energy absorption

$$\begin{aligned} P &= - \frac{A_0 B \omega^2}{2\pi} \int_0^{2\pi/\omega} \cos^2(\omega t) dt \\ &= - \frac{A B \omega}{2} \end{aligned}$$

which, being a negative quantity, shows that the water is doing work on the air.

(ii) For a particle at C the absorption can similarly be shown to be $+ \frac{A B \omega}{2}$

(iii) For a particle at B or E:

$$y = A_0 \cos(\omega t) \text{ and}$$

$$F = B \cos(\omega t)$$

whence the absorption per period is given by

$$\begin{aligned} P &= - \frac{A_0 B \omega^2}{2} \int_0^{2\pi/\omega} \cos(\omega t) \sin(\omega t) dt \\ &= \text{zero.} \end{aligned}$$

(iv) The total absorption per period for a particle at D can similarly be shown to equal zero.

5.4 Effect of damping

If, as an approximation, the damping be assumed viscous (that is, effective damping forces proportional to instantaneous lateral velocity) then at point E the damping is in phase with the driving force due to volume change and reinforces it completely. At point C, on the other hand, damping at all times opposes the disturbing force.

Hence the not entirely unexpected situation exists where damping reinforces the pumping action and opposes absorption. In this respect then increased damping would intensify the motion. As previously mentioned, it was found that by directing the draught from a fan on the lower half of a non-oscillating nappe in a laboratory flume strong oscillations could be induced. The additional pressure from the fan is tantamount to an increase in damping by increased input of energy and the effect tends to confirm the theory presented above.

A fan directed towards a nappe that is already oscillating spontaneously will, in general, merely cause an increase in amplitude but occasionally also a raising of the frequency of oscillation.

5.5 Energy balance

By this stage of the investigation it had become evident that during oscillation a complex inter-relationship exists among the variables discharge, frequency, amplitude, volume of trapped air, damping and egress and ingress of air at the base and sides. An attempt was thus made to discern the overall energy pattern of the phenomenon.

Since steady-state conditions are reached only when the energy input per cycle equals the energy loss per cycle, it follows that if disturbance of a nappe results in a situation where energy input to the trapped air exceeds energy expenditure then, provided that wastage is not excessive, the amplitude will build up rapidly until an energy balance is established, whereupon the thin part of the nappe near the base will probably be split at regular intervals allowing fairly free passage of air inwards and outwards.

Because of leakage the pressure energy available as feed-back would be only a small proportion of the total energy generated and since the movement of air through the nappe would be likely to become more and more restricted with increase in frequency, mainly because of the inertia of air, it was concluded that there must exist a band of frequencies for which the residual energy would be sufficient to sustain oscillation at specific amplitudes.

Should two or three frequencies within the band happen to have approximately equal likelihood of occurrence then the favoured frequency would depend on the nature of the initial disturbance. It was known that one particular frequency would generally predominate over its neighbours in the scale of possible frequencies.

The foregoing hypothesis can be verified to some extent on a model exhibiting nappe oscillation by moving a narrow horizontal baffle held near the tail-water, gradually upstream towards the nappe. Before the baffle reaches the falling water a sudden marked increase in amplitude is observed, evidently attributable to the action of the baffle in inhibiting air from breaking through at the foot of the nappe.

A simple yet instructive demonstration of the effect of air inertia can be carried out in a room which has a light-weight net curtain covering an open window. The door can be completely opened or closed at a rate such that the curtain will not move but rapid oscillation of the door, even through an arc of only a few degrees, will cause the curtain to respond. This effect of the inertia of the air is analagous to that beneath a nappe oscillating at different amplitudes and frequencies.

Parting of the nappe by splitters at intervals along the lip of the crest will obviously reduce the

efficacy with which pressure can be transmitted and if the splitters are spaced closely enough the excess pressure reaching the crest will be evanescent. On the other hand, inertia of the air will also oppose air movement in the direction of the crest and so place a definite limitation on the effectiveness of a splitter which differs for each particular frequency.

Pariset put forward a tentative theory to explain the influence of spacing of splitters. In the light of the analysis in this chapter his theory appears to be correct in principle; more detailed investigation of his approach is, however, considered necessary for determination of practical design rules. It seems clear for instance that the required spacing would be dependent on the height of fall.

5.6 Publication of energy absorption theory

A paper³³ outlining the theory presented in this chapter was submitted to the American Society of Civil Engineers in April 1964 and was published in the journal of their Hydraulics Division in November of that year.

VI. 'LEAKAGE' THEORY

6.1 Introduction to theory

Close observation of the foot of a nappe that is oscillating under stroboscopic illumination reveals that air enters and leaves the nappe at each 'stroke' of the lowermost quarter wave. It was concluded from results of earlier work that the frequency of oscillation is in fact controlled by the leakage rate. To gain further insight into the mechanism of oscillation an analogous system - that of the air in a closed cylinder being compressed by a piston with an orifice in it - was selected for mathematical investigation.

6.2 Non-linearity of the system

The non-linearity of the mechanism governing the motion of an oscillating nappe precludes the possibility of a general solution. There are thus no system roots, the principle of superposition is not valid and it follows that a degree of empiricism must be resorted to in any quantitative study.

The fact that two or more frequencies can be observed for a given set of conditions also implies that the system is non-linear. Figures 6.1 and 6.2 are photographs of a model nappe, the duration of exposure being 30 microseconds, and show the same nappe oscillating at 460 and 600 cycles per minute respectively.

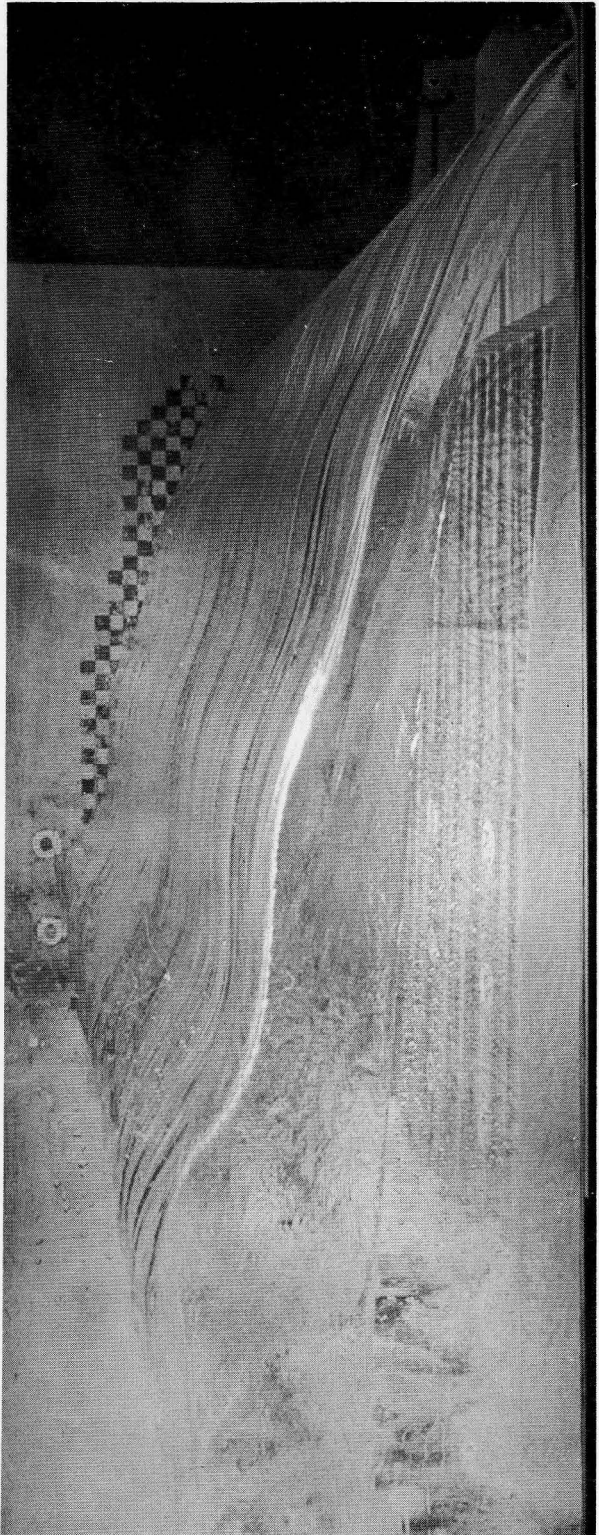

FIGURE 6.1

NAPPE EXHIBITING OSCILLATION AT A
FREQUENCY OF 460 CYCLES PER MINUTE

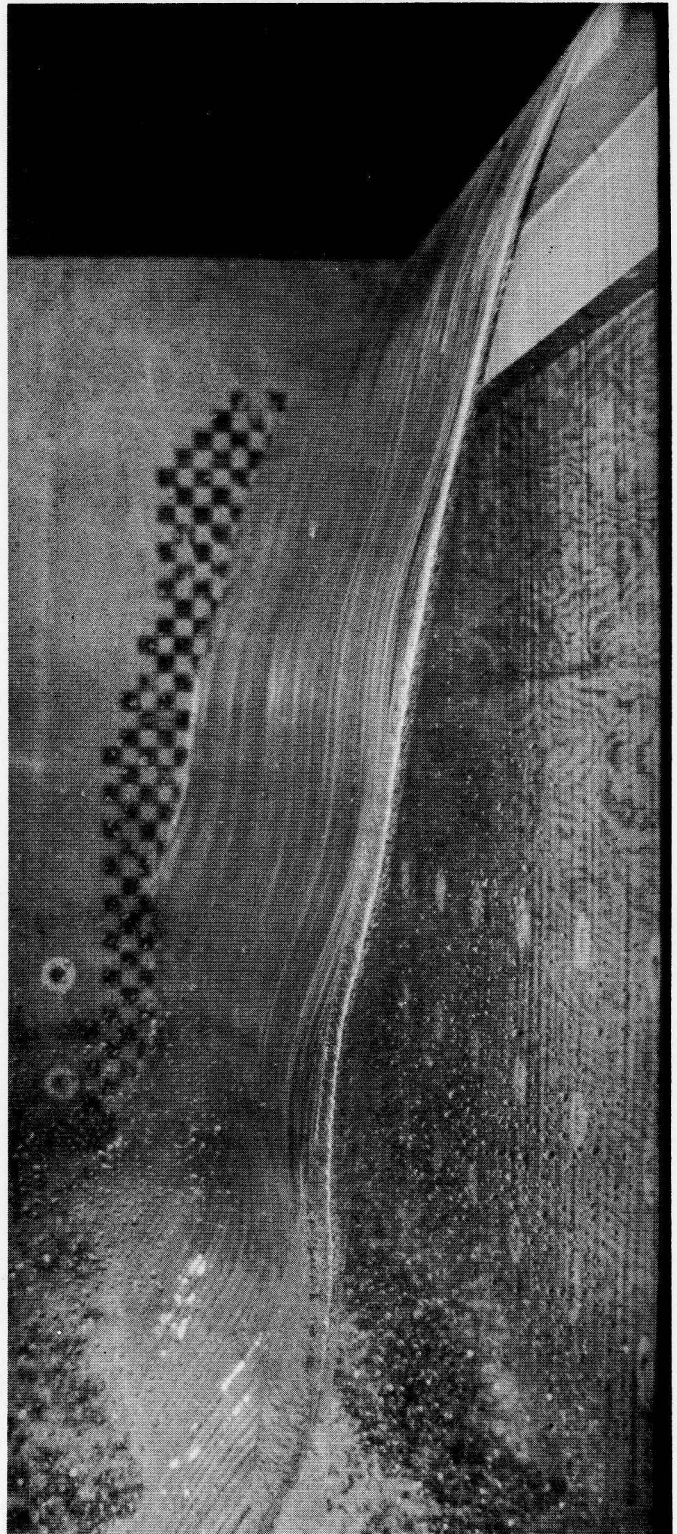

FIGURE 6.2

NAPPE EXHIBITING OSCILLATION AT A
FREQUENCY OF 600 CYCLES PER MINUTE

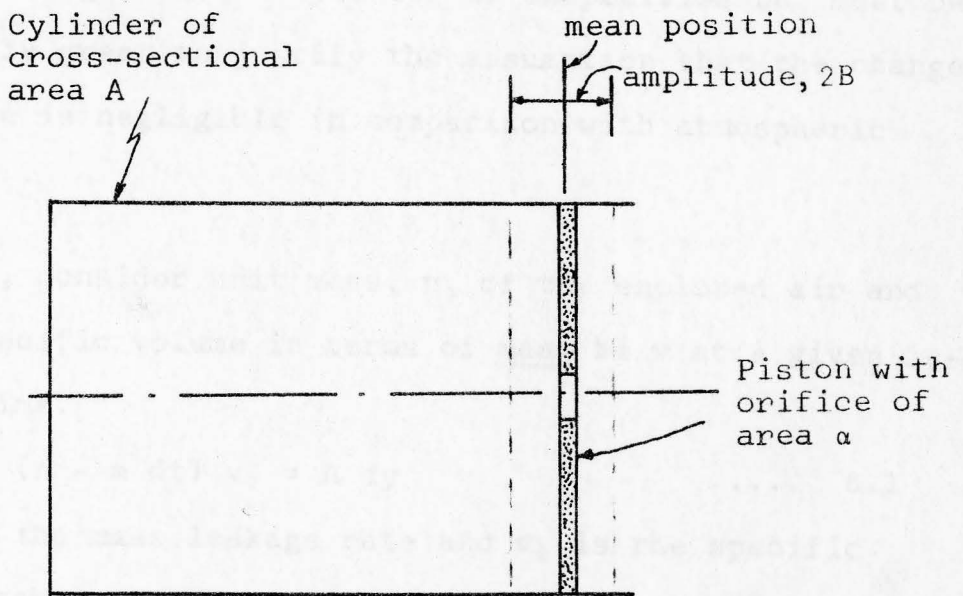

FIGURE 6.3

DEFINITION SKETCH FOR LEAKAGE ANALYSIS

6.3 Leakage analysis for cylinder

Consider a closed cylinder of internal cross-sectional area 'A' as shown on Figure 6.3. A well-fitting piston, in which there is an orifice of area ' α ', is assumed to operate in the cylinder with simple harmonic motion of stroke $2B$.

The length of the cylinder is unspecified but must be sufficiently great to justify the assumption that the change in pressure is negligible in comparison with atmospheric pressure.

Now, consider unit mass, n , of the enclosed air and let the specific volume in terms of mass be v at a given instant of time.

$$\text{Then } nv - (n - \dot{m} dt) v_1 = A dy \quad \dots \quad 6.1$$

where \dot{m} is the mass leakage rate and v_1 is the specific volume in terms of mass an instant later.

For isentropic (i.e. frictionless adiabatic) conditions

$$p(nv)^K = C \quad \text{or} \quad v = \frac{1}{n} \left(\frac{C}{p}\right)^{1/K} \quad \dots \quad 6.2$$

where p is pressure, C is a constant and K is the adiabatic exponent.

Substituting equation 6.2 in equation 6.1

$$\left(\frac{C}{p}\right)^{1/K} - \left(1 - \frac{\dot{m}}{n} dt\right) \left(\frac{C}{p + dp}\right)^{1/K} = (A - \alpha) dy \quad \dots \quad 6.3$$

or, if dp is a negligible proportion of p ,

$$\dot{m} dt = n(A - \alpha) dy \left(\frac{p}{c}\right)^{1/K} \dots 6.4$$

But $dy = B \omega \cos(\omega t) dt \dots 6.5$

$\therefore m = n(A - \alpha) B \omega \left(\frac{p}{c}\right)^{1/K} \cos(\omega t) \dots 6.6$

Now the mass leakage rate \dot{m} is given by

$$\dot{m} = \frac{\alpha}{g} \sqrt{\frac{2 g k}{K-1} p \gamma \left\{ \left(\frac{p_a}{p}\right)^{2/K} - \left(\frac{p_a}{p}\right)^{\frac{K+1}{K}} \right\}} \dots 6.7$$

By rearranging the expression in curly brackets in equation 6.7 and expanding by the binomial theorem a much simplified version of equation 6.7 can be obtained as follows:

The term

$$\left\{ \left(\frac{p_a}{p}\right)^{2/K} - \left(\frac{p_a}{p}\right)^{\frac{K+1}{K}} \right\}$$

can be written thus

$$\left\{ \left(1 - \frac{\Delta p}{p}\right)^{2/K} - \left(1 - \frac{\Delta p}{p}\right)^{\frac{K+1}{K}} \right\} \dots 6.8$$

Binomial expansion of this expression with rejection of second-order and higher terms of Δp yields

$$\left\{ 1 - \left(\frac{2}{K}\right) \frac{\Delta p}{p} \right\} - \left\{ 1 - \left(\frac{K+1}{K}\right) \frac{\Delta p}{p} \right\}$$

which is equal to $\frac{\Delta p}{p} \left(\frac{K-1}{K}\right)$

Hence $\dot{m} = \alpha \sqrt{2 \rho \Delta p} \dots 6.9$

where $\rho = \gamma/g$

Combination of equations 6.4 and 6.9 gives

$$\sqrt{\Delta p} = \frac{n(A - \alpha)B}{\alpha\sqrt{2\rho}} \left(\frac{p}{c}\right)^{1/K} \cos(\omega t) \quad \dots \quad 6.10$$

The peak positive value of Δp occurs when

$$t = 0, 2\pi, 4\pi \dots$$

i.e. when $\cos(\omega t)$ equals unity.

Hence the peak value of Δp , is given by

$$(\Delta p)_{\max} = \left(\frac{A - \alpha}{\alpha}\right)^2 \frac{B^2 \omega^2 \rho}{2} \quad \dots \quad 6.11$$

or if ' α ' is a small proportion of A

$$(\Delta p)_{\max} = \left(\frac{A}{\alpha}\right)^2 \frac{B^2 \omega^2 \rho}{2} \quad \dots \quad 6.12$$

This equation shows that the peak value of pressure generated varies as the square of

- (a) the piston area to orifice area ratio
- (b) the frequency, and
- (c) the amplitude.

It should be noted that the peak value is independent of the volume of the enclosed air in the cylinder as long as the assumptions made are valid - that is, as long as Δp remains a negligible proportion of atmospheric pressure.

6.4 Typical numerical example

Numerical values for a typical oscillating nappe show that the peak value of p is indeed a very small proportion of atmospheric pressure. For example, if

$\alpha = \frac{A}{100}$, $B = 0.01$ ft, $\rho = 0.0025$ slug/cu.ft.

and $\omega = 50$ cycles per second

$$\begin{aligned} \text{then } (\Delta p)_{\max} &= \left(\frac{A}{A/100}\right)^2 \times \left(\frac{1}{100}\right)^2 \times \frac{50^2 \times 0.002}{2} \\ &= 2.5 \text{ lb/sq.ft.} \end{aligned}$$

(i.e. about 0.15 per cent of atmospheric pressure)

This numerical result is of the order expected from recorded measurements of pressure beneath oscillating nappes.

6.5 Application of leakage analysis to nappe oscillation

The first conclusion to be drawn from equation 6.12 is that the volume under the nappe does not control the frequency directly as long as it is sufficiently large to justify the assumptions made in the analysis. By altering the position of a movable backing sheet behind an oscillating nappe on a model the author established that fairly substantial alteration of volume or air trapped does not necessarily change the dominant frequency.

Secondly, since the lowermost quarter wave-length is approximately proportional to the inverse of frequency it follows that the effective open area of the split portions of the nappe probably varies inversely with the frequency, i.e. $\alpha = \frac{K_1}{\omega}$

$$\text{Hence } (\Delta p)_{\max} = \left(\frac{A}{K_1}\right)^2 \frac{B^2 \omega^4 \rho}{2} = K_2 (A^2 B^2 \omega^4)$$

$$= K_3 B^2 \omega^4 \quad \dots \quad 6.13$$

for a given fall distance.

The value of B decreases with increase in frequency and increases with increase in Δp . Hence it follows from equation 6.13 that certain different combinations of Δp , B and ω could satisfy the equation.

Some preliminary tests were carried out using an 8" internal diameter steel pipe, 6 ft long, at one end of which operated a piston driven by a variable-speed variable-stroke motor assembly. In the piston were four holes fitted with removable rubber plugs. At the other end of the pipe, which was closed off by a blank flange, pressure responses observed on a Betz micromanometer, exhibited the expected trends. The manometer, although sensitive, does not, however, respond rapidly enough for the full range investigated and proper verification of the theory awaits the development of suitable electronic pressure recording devices.

VII. ANALYSIS OF SYSTEM BEHAVIOUR

"Detailed studies of the real world impel us, albeit reluctantly, to take account of the fact that the rate of change of physical systems depends not only on their present state, but also on their past history."

R. Bellman and K.L. Cooke³⁴

7.1 Preliminary considerations

Several research workers in the field of nappe oscillation have attempted to set up differential equations to describe in mathematical terms the overall behaviour of the system. None, however, seems to have recognised explicitly the fact that the forces involved at any given instant depend to some extent on part of the preceding motion.

Most dynamic systems are described by ordinary differential equations which may be interpreted as representing systems where interactions are, for all practical purposes, instantaneous. Expressed in another way, it is tacitly assumed that time lags of finite duration are negligible and that the rate of change of the system at any time depends only upon its characteristics at the instant under consideration.

Since external excitation is absent from the nappe

system the oscillation can only be self-sustaining if there is a finite time lag between disturbances of the nappe and its self-correction. The dynamic system is thus not directly describable in terms of a differential equation of finite order and recourse must be had to mathematical techniques developed specifically for representation of system behaviour in situations where hereditary characteristics are of primary concern.

A comprehensive survey of control problems was presented by Minorsky³⁵ in 1941 and his treatment of the subject includes a discussion on stability criteria for retarded actions.

The mathematical techniques available for handling control problems include the use of hystero-differential equations. Equations which depend on the complete past history of the system are generally designated by mathematicians as integrodifferential equations whereas those which depend only on a certain fixed period of the preceding motion are referred to as differential - difference, difference-differential or delay differential equations.

An equation of the form

$$a_0 \dot{x}(t) + a_1 \dot{x}(t - 1) + b_0 x(t) + b_1 x(t - 1) = f(t)$$

is said to be of the neutral type if the coefficients a_0 ,

a_1 , b_0 and b_1 are not equal to zero. It will be seen that when all the coefficients are greater than zero the current rate of change of a quantity depends on the past rate of change as well as on the past and present values of the quantity. Other designations apply when one of the constants has a value zero. For example, the equation is said to be of the retarded type if the coefficient a_1 equals zero, and of the advanced type where the coefficient a_0 equals zero. In the latter case the rate of change of a quantity depends on present and future values of the quantity (or alternatively, the present value depends on the past value and the past rate of change).

Where both a_0 and a_1 equal zero (or b_0 and b_1 equal zero) the equation is referred to as a pure difference equation.

According to Bellman and Cooke³⁴ the description of equations as either retarded, neutral or advanced was used by A.D. Myskic in "Lineare Differentialgleichungen mit nacheilendem Argument" (Berlin 1955 - translation of 1951 Russian edition). Differential-difference equations were first encountered in the eighteenth century and Volterra³⁶, in a paper entitled "Vibration of elastic systems having hereditary characteristics", mentions that Boltzmann used the delay concept in 1876.

7.2 Retarded action

Bateman³⁷ (1945) gave an interesting account of control theory based upon first order perturbation theory. He traced the development of the effect of retarded action from early work on the hunting of governed engines (1894) to the most recent work at the time of presentation of his paper in 1943. He then classified the usual mathematical methods of handling problems in which time lags are significant under the following three headings:-

- (i) by the use of Taylor's theorem and a neglect of small terms so that linear differential equations are obtained,
- (ii) by the use of differential-difference equations or equations of mixed differences and
- (iii) by the use of integral equations of the Poisson-Volterra type.

The rapid growth of automation following World War II gave tremendous impetus to the development of feed-back control techniques and the literature on the subject is now extensive. Minorsky published several additional papers on linear problems as well as a book on non-linear mechanics. In a paper³⁸ published during the war he described an exhaustive investigation into a modified pendulum system for which he took account of retardation in damping in a hystero-differential equation of motion. He regarded the differen-

tial equation as an asymptotic form thereby avoiding the necessity of neglecting terms in an equation of higher order.

Poritsky³⁹, in discussing the paper, showed that to solve the equation set up by Minorsky it was unnecessary to demonstrate that a difference-differential equation was equivalent to a linear differential equation of infinite order since the solution could be obtained directly upon assuming an exponential solution. He commented further: "In general, a linear difference-differential equation admits exponential solutions in a manner quite similar to that of an ordinary linear differential equation, except that, whereas in the latter case the determination of the exponents reduces to an algebraic equation, in the present instance it reduces to a transcendental one."

Collatz⁴⁰ examined the stability characteristics of a difference-differential equation by assuming an exponential solution to obtain a transcendental characteristic equation and Minorsky in a later paper also adopted the direct exponential solution.

Unfortunately the full physical significance of delays in displacement or damping is not easily discernible when the exponential solution is employed. The significance is perhaps more easily grasped if an approximate solution is sought. For example, on expansion of the retarded terms in

a Taylor series it becomes immediately apparent that delayed displacement is equivalent to reduction of the damping coefficient (which signifies the introduction of energy to the system) and that delayed damping effectively reduces the inertial term.

In a mathematical note⁴¹ contained in a comprehensive series of articles by the editorial staff of "The Engineer" (1937) on the principles and practice of automatic control it is shown that the equation

$$\ddot{X} + Q\dot{X} + Nf'(t-h) + Pf(t-k) = 0 \quad \dots \quad 7.1$$

can be approximated by the use of Taylor's expansion for the delay terms as follows:-

$$\left(1 - Nh + \frac{Pk^2}{2}\right) \ddot{X} + (Q + N - PK) \dot{X} + PX = 0 \quad \dots \quad 7.2$$

In the absence of delayed damping (i.e. $N = 0$) it can be seen that the oscillation will not decay if the delay, k , equals or exceeds the ratio of the natural damping coefficient, Q , to the coefficient of the delayed displacement term, P .

Pipes⁴², in a presentation of a mathematical discussion on retarded systems adopts the Laplacian transformation as a means of retaining the physical significance of the solution process.

7.3 Non-linearity of the system

The sheet of water may be looked upon as oscillating because its centre of gravity moves to and fro. The system may perhaps best be regarded as a non-linear oscillator comprising a delay, an amplifier and a limiter.

The non-linear characteristics of the limiter, are difficult to establish experimentally because the dynamic processes involved are so small. However, as no stationary amplitude would be possible in a resonant system were it not for inherent non-linearity, it may be assumed that the splitting of the nappe is such that a certain saturation pressure is reached for each given combination of frequency and spread. It is also assumed that although the distortion introduced by the limiter may be appreciable the wave form of the resulting motion is distinctly periodic.

The energy extracted may be considered to be negligible in comparison with that possessed by the jet. On the other hand, some energy must be absorbed in overcoming the damping.

Since motion is actuated through couplings without the imposition of an external periodic force the oscillating system may be described as being in a state of resonance, with the component parts tuned to a common frequency.

7.4 Time-lag

An analagous mathematical treatment for the system under consideration can be found in the literature on signal transmission systems where fixed time intervals are required for the propagation of a signal from one end of a transmission line to the other.

However, for the nappe the situation is more complex because the time of influence of a sudden change in pressure difference across the nappe varies from zero, for a particle at the junction of the nappe and the tail-water, to the full fall time for a particle about to leave the weir crest. Since, as was shown in Chapter III, the effect of pressure variation on particles near the crest is all-important in establishing the nappe profile pattern, it is proposed that an 'effective retardation' or 'equivalent time lag' (equal to some proportion of the time of fall from weir lip to tailwater) can be invoked. This concept of an equivalent time lag, to account for the influence of heredity, is introduced in the analysis presented later in this chapter.

Although it could be argued that any delay would affect both displacement and damping it will be assumed in the analysis that follows that the coefficient of applied damping is negligible. It seems probable, however, that retarded damping will become a relevant factor in determi-

nation of the stable amplitude of the oscillation.

7.5 Electrical analogue

Taking into account the considerations discussed earlier in this Chapter the author has concluded that an oscillating nappe system can satisfactorily be represented by an equivalent electrical circuit comprising a delay with fixed lag, an amplifier with positive gain and a limiter with non-linear characteristics. The circuit is illustrated in the block diagram, Figure 7.1, where the values of e represent instantaneous voltages and the boxes or sub-assemblies represent circuits defined as follows:-

Box A represents a delay circuit with lag, τ .

$$\text{Hence } e_2(t) = e_1(t-\tau).$$

Box B represents an amplifier with gain, G .

$$\text{i.e. } e_3(t) = G e_2(t)$$

Box C represents a limiter circuit with a saturation relationship which is probably discontinuous in the case of the nappe but is, for convenience, chosen as the continuous function:

$$e_3(t) = p e_4(t) + q \{e_4(t)\}^3$$

The circuit is not a reversible one and current flows in the direction shown. It will be seen that $e_1(t) = e_4(t)$. In all cases the argument at which each term is to be evaluated is denoted in the bracketted portion

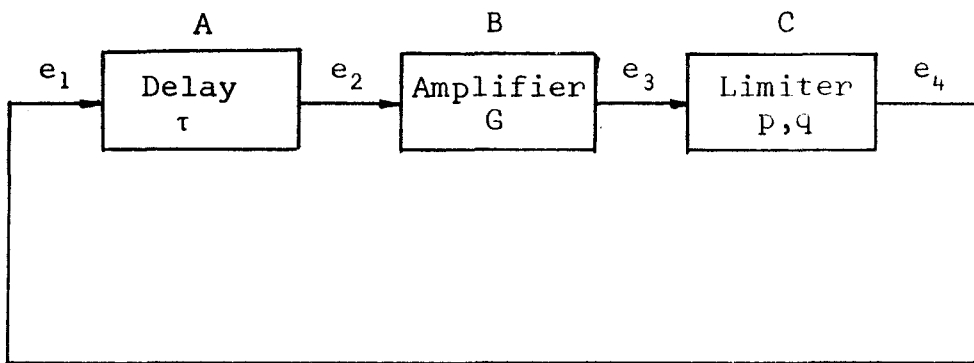

FIGURE 7.1

CIRCUIT DIAGRAM FOR NON-LINEAR
OSCILLATOR WITH DELAY
(AFTER CUNNINGHAM)

of the subscript.

Combining the voltage relationship yields the following non-linear difference equation:-

$$x(t) - Cx_{(t-\tau)} + gx^3(t) = 0 \quad \dots \quad 7.3$$

where $x = e_1$, $C = G/p$ and $g = q/p$

According to Cunningham⁴³ possible oscillation frequencies for the circuit are in the ratio of small integers. The non-linear action of the limiter will generate sum and difference frequencies so that other frequencies will be present when the steady state is reached.

Because of the presence of a delay, discrete initial conditions cannot be applied as in the case of a pure differential equation. In fact, the frequency and waveform generated will depend largely upon the manner by which oscillations in the system are initiated.

The oscillatory system is self-starting in that if conditions are propitious any small perturbation causes oscillation to build up until a steady state is achieved. The behaviour of the system depends upon the ratio of G/p and as can be seen from Figure 7.2 the transition period increases as the absolute value of the ratio G/p decreases towards the value unity.

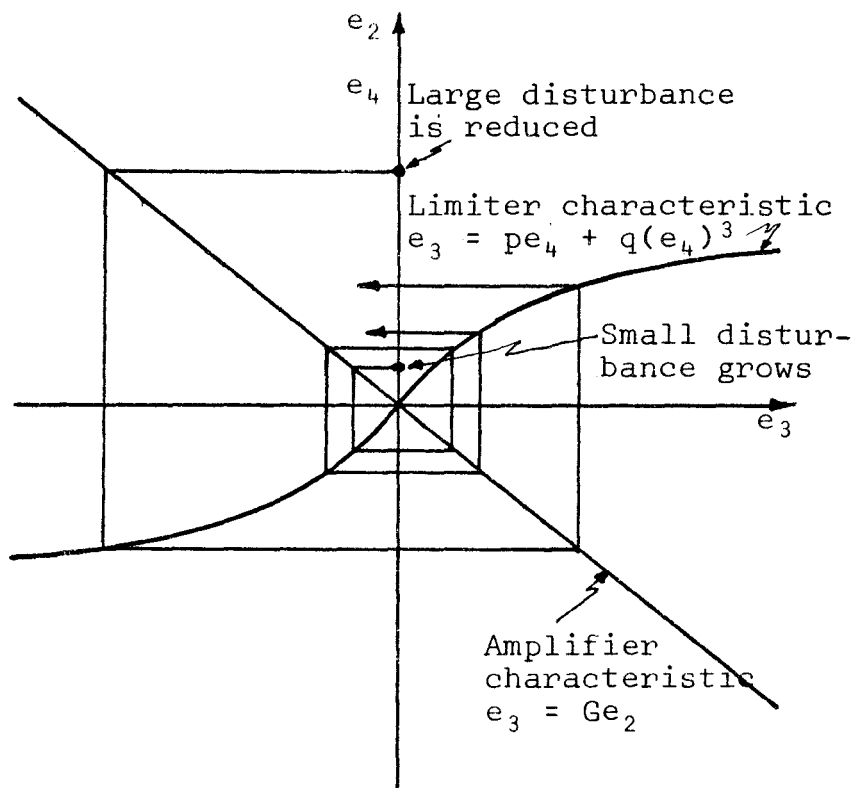

FIGURE 7.2

DIAGRAM ILLUSTRATING THE MODE OF ESTABLISHMENT OF A QUASI-STABLE AMPLITUDE

Small disturbances will grow whereas unusually large disturbances will be reduced by the throttling action of the limiter until what Poincaré calls limit cycles (cycles limités) are reached. It will be clear from a study of the diagram that if the absolute value of the ratio G/p is less than unity any disturbance, no matter how large, will be suppressed. The behaviour of the nappe for the case where the absolute magnitude of the G/p ratio is close to unity may be examined by writing equation 7.3 in the following form:-

$$x(t) - C_0 x(t-\tau) - h C_0 x(t-\tau) + g x^3(t) = 0 \quad \dots \quad 7.4$$

where $C = C_0(1 + h)$ and represents the net amplification around the circuit. C_0 is ± 1 and h is a small positive quantity. The coefficient g is related to the non-linear properties of the limiter.

By assuming that the motion is dominated by a single frequency a steady state amplitude can be calculated using equation 7.4. This would correspond to the amplitude of the centre of gravity of the nappe and not the 'apparent amplitude' or deviation of water particles from the equilibrium trajectory.

7.6 Interpretation of analogue

As shown by the analysis in Chapter III, the delay, τ , is a function of and nearly equal to the fall time.

Also, the amplifier gain, G, depends on the frequency since both the spread and the number of wavelengths are known from mathematical analysis to vary with frequency.

The splitting of the nappe near its foot, together with the nature of defined ventilation points, controls the dynamic pneumatic stiffness as shown by the analysis in Chapter VI and thus determines the numerical values of the constants p and q in the saturation relationship.

If the nappe is relatively thick the net gain will obviously be less than unity. On the other hand, if the nappe is so thin that splitting is appreciable, consequent loss of pressure will also limit the net gain. Hence it follows that for optimum oscillation conditions the nappe should be neither too thick nor too thin. This implies that oscillation will take place only within a certain range of discharge and this indeed is the case in practice.

No special tuning is called for since the nappe can readily adapt itself to oscillate within a wide band of frequencies. The values of angular frequencies that can operate differ from each other by 2π radians and satisfy the relationship

$$\omega \propto (K + \frac{1}{4})$$

The value of K will be a low integer. If the integer is too low for any particular set of circumstances the net pressure feedback may be insufficient to maintain self-

excitation and, depending on the nature of the initial disturbance, one of the next few values of K will establish the actual frequency.

Figure 7.3 shows a plot of frequency against $(K + \frac{1}{4})$, with time of fall as parameter. Several recorded observations from experimental work at the University and from the literature are shown.

Some interesting conclusions can be drawn from examination of the graph. First, it would seem that for small fall distances (say less than two feet) self-sustained oscillation is unlikely to occur because the one or two possible frequencies are ruled out either by excessive leakage or by excessive mass.

Secondly, and perhaps most significant from an engineering point of view, the sensitivity of frequency can be seen to decrease with fall distance so that any of several values of $(K + \frac{1}{4})$ becomes possible. This seems to be the case for fall times of about one to two seconds, corresponding to fall distances of about 16 to 64 ft. Reference to figure 4.2 will reveal that this is borne out in practice. As the fall distance increases, however, the possible frequencies become so low that for small values of the integer, K , oscillation again becomes extremely unlikely.

It would thus appear that for high dams with clear

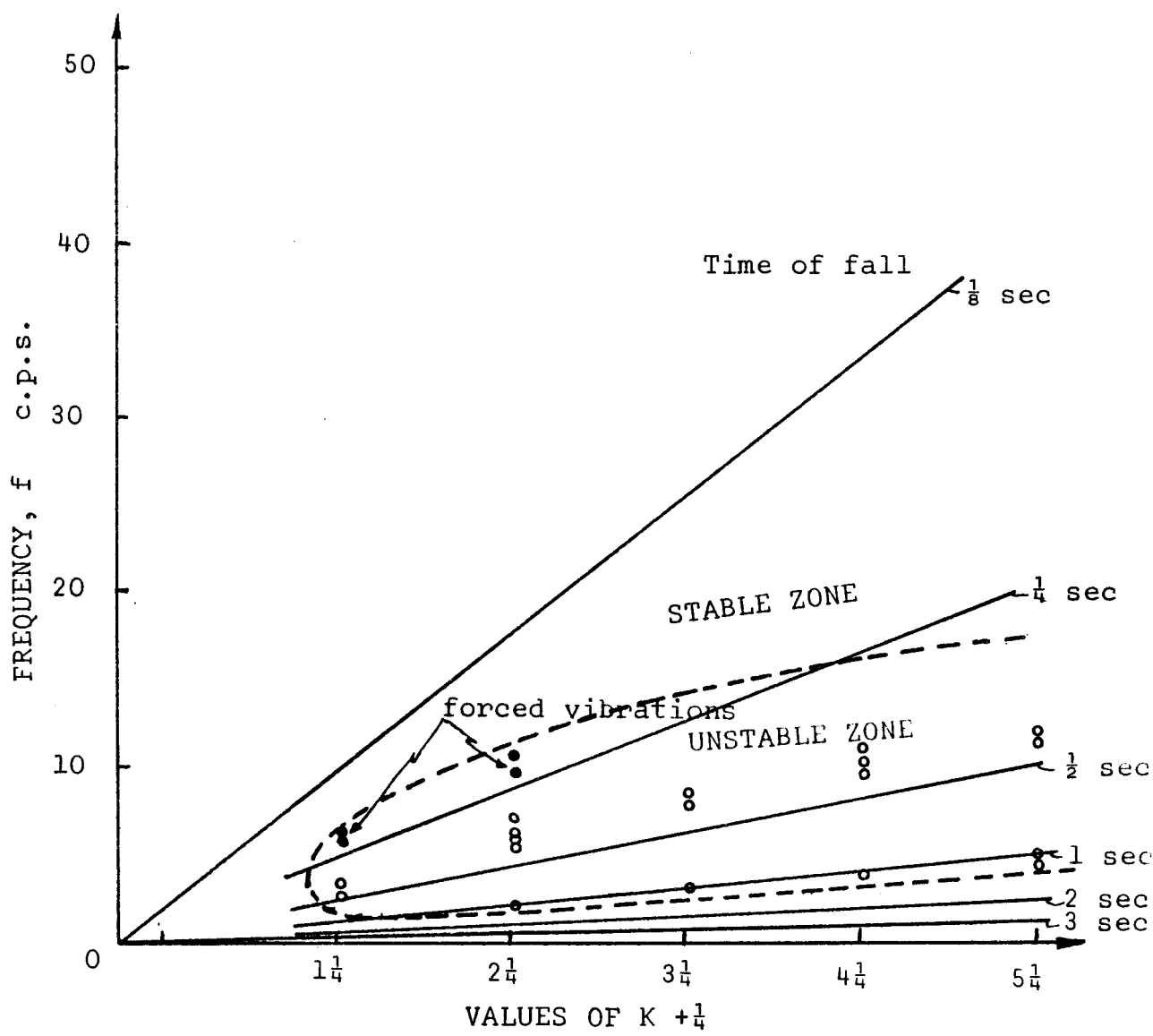

FIGURE 7.3

DIAGRAM ILLUSTRATING THE DEGREE
 OF SENSITIVITY OF NAPPES SUBJECT
 TO VARIOUS TIMES OF FALL

drops in excess of about 150 ft the possibility of quasi-stable oscillation becomes remote. It follows that the necessity for providing nappe interruptors on high dams with a clear drop of 150 ft or more falls away, particularly where the fall height varies across the river section.

A further inference from the results of this study is that nappe oscillation is unlikely to occur on any spillway in which the water leaves a flip bucket at an upward angle of about $\frac{\pi}{4}$ radians because small disturbances applied to the nappe would not then be subject to pronounced negative gain.

7.7 Publication of delay theory

The idea of application of the delay concept to nappe oscillation was contained in the paper³³ entitled 'Nappe Oscillation' published in the Hydraulics Division of the Proceedings of the American Society of Civil Engineers in November, 1964, and developed further in the Author's Closure to the discussion⁴⁴ published in January, 1966. Eduard Naudascher⁴⁵, Associate Professor of Mechanics and Hydraulics at the University of Iowa, in a contribution to the discussion stated that his first reaction to the suggestion made by the author in 1962 (viz. that boundary layer effects play a role in the excitation mechanism of nappe oscillation) had been doubt concerning the relative importance of these effects, but that recently he had come to

realise that the characteristics of boundary-layer instability could indeed be the key to many of the still-unknown aspects of the oscillating nappe phenomenon. He also drew attention to the remarkable similarity between jet-edge and nappe oscillation phenomena.

In a comprehensive discussion of the Author's paper, Professor K. Petrikat and Dr. T.E. Unny⁴⁶ of the Technische Hochschule in Stuttgart, Germany, outlined the theories developed in Germany for the prediction of the initiation of nappe undulation and stated that the treatment of the bottom portion of the nappe acting as a pumping zone feeding energy into the system was excellent and merited appreciation. They then went on to develop a ' $K + \frac{3}{4}$ ' criterion for the ratio of possible frequencies on an elastic crest as a complement to the development of the ' $K + \frac{1}{4}$ ' criterion for rigid crests. They followed this with an analysis for determining the fall heights that would induce self-excited vibration of elastic flaps.

Following on Naudascher's suggestion that jet-edge systems and nappe oscillation had much in common, the author found that many highly controversial aspects of jet-edge theory could readily be resolved using knowledge already accumulated in studies of nappe oscillation. The next chapter is accordingly devoted to a study of the similarities between the respective mechanisms of edgetones and nappe oscillation.

XIII. EDGETONES AND NAPPE OSCILLATION

"The mechanism of edgetones ... has an interest much beyond that which would exist for the subject in itself, because of its bearing on a host of acoustical and hydrodynamical problems."

8.1 A review of the literature on edgetones

The edgetone has been defined by Powell⁴⁸ as "the sound resulting from the action of a jet emerging from a slit orifice and impinging upon a fixed cylinder (traditionally a wedge but called an edge) symmetrically placed and parallel to the length of the slit."

The controversial phenomenon of edgetones or Schneidentöne has been studied by physicists since the middle of the 19th Century^{49,50}.

Considerable research work in this field was carried out by Helmholtz⁵¹, Wachsmuth⁵², König⁵³, Schmidtke⁵⁴, and others but, despite all this, Lenihan and Richardson⁵⁵ stated in 1940 that the problem of edgetones was "one which continues to form a battleground for rival theories".

As in the case of nappe oscillation hysteretic behaviour has been observed for jet-edge systems and the

various possible phases are referred to by Brown^{56,57} as 'stages'.

In a paper on the mechanics of edgetones published in 1953, Curle⁵⁸ drew attention to the fact that the ratio of wavelengths for a given set of conditions appeared from results published by Brown to be an integer plus one-quarter. At about the same time Powell came to a similar conclusion.

No direct reason was advanced by Curle for this contention but he championed the idea that weak vortices were shed on alternate sides of the jet at appropriate intervals. These vortices, it was suggested, developed in strength as they proceeded.

Many attempts have been made to predict mathematically the instability characteristics of potential flow jets by application of small pressure and velocity disturbances but the underlying assumptions are generally far removed from reality and so may give erroneous indications.

Nyborg⁴⁷ sought to explain the feedback by means of a mathematical analysis of the effects of transverse pressures but according to Gross⁵⁹, who investigated underwater edge-tones, did not adequately explain how the pressure arose. Gross concluded, with certain reservations, that Nyborg's theory afforded a valid first approximation to the theory of feedback.

Despite the multitude of papers that have appeared on the subject of edgetones since 1940, it must even now be conceded that the problem has by no means been satisfactorily resolved.

In Powell's comprehensive analysis of the mechanism of edgetones he states that the influence of disturbances can be assumed to be concentrated at the orifice. As shown in Chapter III, however, such an assumption may for nappe oscillation lead to false conclusions.

It should be noted by those who try to interpret Brown's experimental results (Ref. 56, Table II) that it is apparent from the ' $K + \frac{1}{4}$ ' criterion that the value of 1 cm assumed for the wavelength by Brown was incorrect since the slit to edge distance was 1 cm.

Powell concluded that the action of a jet-edge system had non-linear characteristics and that the mechanism could crudely be described as a multimode oscillator with dependent time delay and a limiter of low harmonic distortion, structurally stable except for certain prominent unstable regions. No formal mathematical description was given for his theory; deductions were drawn directly from physical considerations.

In his concluding remarks Powell stated that recognition of the essential non-linear action of established

tone suggested a mechanism of the hysteretic frequency jumps and also made possible a realistic estimate of the upper limit of the edgetone force.

8.2 Comparison between the edgetone and nappe oscillation phenomena

One of the most notable features of the edgetone and nappe oscillation phenomena is that both exhibit hysteretic behaviour and that the number of wavelengths is invariably an integer plus one-quarter. This implies that for a fixed initial velocity a series of stages or eigenfrequencies are possible: up to six stages have been observed for edgetones⁶⁰ and the author³³ has successfully induced up to five stages on a model nappe.

The frequencies induced are such that the integer is a low number, generally below twelve.

For a submerged or homogeneous jet (e.g. air in air or water in water) the effect of gravity can be eliminated from the equations developed in Chapter III for water nappes in air and it can be shown that for a sinusoidally varying pressure difference across the jet the curvature at the origin varies as

$$\alpha \cos (\omega t + \beta).$$

At the origin of the jet the maximum algebraic value of the curvature occurs when the applied transverse harmonic

pressure has its maximum or minimum value; the curvature is zero when the pressure is zero. Despite the fact that the elements that leave when the pressure is zero are not deviated at the orifice it can be shown that these elements eventually deviate further from the equilibrium trajectory than those that leave when the pressure difference is greatest. This analysis is developed in the next section.

8.3 Trajectories of elements of a submerged jet

If it is assumed that the jet velocity remains constant when subjected to sinusoidally varying transverse pressure forces then, because the jet would not be subject to differential gravitational influence, the equations of motion can be written as follows (cf. reference 28)

$$p\dot{y} = \ddot{x} \quad \dots \quad 9.1$$

and
$$p\dot{x} = \ddot{y} \quad \dots \quad 9.2$$

where
$$p = \frac{F \cos(\omega t)}{\rho q}$$

x is the direction of projection,

F is the peak transverse pressure,

ρ is the mass density of the jetted fluid, and

q is the unit discharge.

By differentiation of equation 9.1 and substitution it can be shown that

$$\frac{\ddot{x}}{p} - \frac{\dot{p}}{p^2} \dot{x} + p\dot{x} = 0 \quad \dots \quad 9.3$$

Similarly,

$$\frac{\ddot{y}}{p} - \frac{p}{p^2} \ddot{y} + p\dot{y} = 0 \quad \dots \quad 9.4$$

No general solution to these equations is known and it appears likely that Bessel functions would have to be invoked to yield an approximate solution. Since, however, a reliable numerical method of solution is already available (see Chapter III) it was considered that the mathematical investigation need not at this stage be further pursued.

An alternative approach would be to examine directly the effect on pressure variation of a single particle subject to sinusoidally varying forces.

The effect is proportional to

$$(L - x) \cos (\omega t) dt \quad \dots \quad 9.5$$

where L is the distance from slit to edge, t denotes time and ω is the angular velocity.

It can be shown that if integration is carried out by parts then the effect sought is proportional to

$$\begin{aligned} & (L - V_0 T_2) \sin (\omega T_2) - \frac{V_0}{\omega} \cos (\omega T_2) \\ & - (L - V_0 T_1) \sin (\omega T_1) + \frac{V_0}{\omega} \cos (\omega T_1) \quad \dots \quad 9.6 \end{aligned}$$

where $L = V_0(T_2 - T_1)$ and V_0 is the jet velocity.

Insertion of appropriate values of T_2 and T_1 for a jet oscillating with ' $K + \frac{1}{4}$ ' wavelengths produces curves similar to the dotted lines in Figures 3.4 and 3.5 without, of course, the increase in wavelength due to gravitational acceleration.

For an actual jet it is well established that after the jet has travelled about five slit widths the assumption of constant jet velocity can no longer be substantiated and for a numerical solution suitable modifications would accordingly have to be made to the above analysis.

8.4 Publication on edgetones

In August 1965 a paper entitled "Edgetones and Nappe Oscillation" was submitted by the Author to the Acoustical Society of America with the object of drawing to the attention of research workers in the acoustics field knowledge gained in the studies relating to nappe oscillation. The paper⁶¹ was published in March 1966.

Experimental investigations carried out by researchers in the edgetone field have been confined to jets that are submerged (usually air in air or water in water).

The results of investigations into nappe oscillation (a water jet in air), however, permit clarification of some of the difficulties previously encountered. For instance it becomes quite evident that the vortices photographed by Brown resulted from the oscillation since they

are clearly separation vortices. In addition, further evidence became available for the validity of the integer plus one-quarter criterion for the number of wavelengths contained in the oscillating jet.

Values of $\frac{U}{n\lambda}$ (Brown's notation) calculated from the data in Brown's tables II and III are shown in the last column of Table 8.1.

It would be expected that if the jet velocity were constant the value of $\frac{U}{n\lambda}$ would be unity. However, for all the observations in Table II and the last four of Table III the mean value of $\frac{U}{n\lambda}$ is 2.55; the scatter is not great. Similarly in Table III the first four observations yield a mean value of 4.36 and the next eleven, 3.37.

The difference between these values suggests that the jet width was altered during the experiments.

Several investigators have made extensive use of Brown's results and on the assumption that the jet velocity remains constant have drawn incorrect conclusions. The controversy that has raged on this topic may perhaps be resolved if cognisance is taken of the fact that for a non-oscillating submerged jet the centreline velocity drops appreciably after the jet has travelled a distance of about five times its initial thickness⁶².

For an oscillating jet, break-through of air

from one side to the other will presumably tend to slow down the jet even more than is the case for an undisturbed jet.

The values in the penultimate column of Table 8.1 when compared with the measured wavelengths demonstrate clearly the validity of the ' $K + \frac{1}{4}$ ' criterion but it should be noted that in each instance the wavelength λ probably varied along the jet and was measured where the jet velocity had not been appreciably reduced.

Chanaud & Powell⁶³ recognised that a submerged jet expands rapidly and suggested that there are in fact two types of jet stability, the first being with respect to small disturbances; the second, a stability of apparent vortex rows which result from instability of the original jet flow.

In a more recent paper Powell⁶⁴ comments on some experiments carried out with a hot-wire anemometer in an air jet and suggests that the fraction to be added to an integer for the number of 'cycles of spacewise disturbance of the jet' would not be exactly one-quarter. He advocates further research and avers that better understanding of the complex interactions might lead to modifications to the simple value of one-quarter.

In the case of edgetones it is possible that Powell may indeed be correct but for nappe oscillation

Table 8.1 - Analysis of observations taken from tables II and III reference 56.

	h cm	U cm/sec	λ cm	n cps	Stage	$\frac{h}{K+\frac{1}{4}}$	$\frac{U}{n\lambda}$
Table II	3.5	215	0.85	97	IV	0.83	2.61
	3.0	237	0.90	97	III	0.92	2.72
		248	0.93	97	III	0.92	2.75
		321	0.68	194	IV	0.70	2.63
		253	0.51	194	V	0.57	2.56
	2.5	185	0.75	97	III	0.77	2.55
		210	0.81	97	III	0.77	2.67
		380	0.77	194	III	0.77	2.55
		391	0.56	291	IV	0.59	2.40
		508	0.57	388	IV	0.59	2.30
	2.0	227	0.89	97	II	0.89	2.63
		422	0.57	291	III	0.61	2.55
		550	0.59	388	III	0.61	2.41
1.5	200	0.78	97	II	0.67	2.67	
	345	0.64	194	II	0.67	2.78	
	502	0.64	291	II	0.67	2.69	
1.0	268	1.00*	97	I	0.80	2.76	
	342	0.45	291	II	0.45	2.61	
	517	0.43	485	II	0.43	2.49	
1.17	616	0.36	800	III	0.36	2.14	
Table III	3.50	138	1.51	20	II	1.55	4.56
		142	1.56	21	II	1.55	4.35
		162	1.51	25	II	1.55	4.30
		187	1.50	29.5	II	1.55	4.23
		200	1.55	36	II	1.55	3.59
		140	1.00	36	III	1.08	3.89
		185	1.05	50	III	1.08	3.52
		186	1.02	53	III	1.08	3.44
		210	1.04	58.5	III	1.08	3.44
		212	1.07	59	III	1.08	3.37
		245	1.08	71.5	III	1.08	3.17
		254	1.02	75	III	1.08	3.32
		277	1.11	84	III	1.08	2.97
		271	1.00	84	III	1.08	3.23
		283	1.02	89	III	1.08	3.12
		283	0.90	125	IV	0.83	2.51
		272	0.87	126	IV	0.83	2.48
		305	0.88	143	IV	0.83	2.42
		311	0.81	147	IV	0.83	2.62

*Value assumed by Brown

there can be little doubt that if the time of travel of the disturbance through the air can be neglected, and this is a reasonable assumption for most practical cases, then the value of the fraction would be very close indeed to one quarter.

IX. SUMMARY AND CONCLUSIONS

9.1. Self-excitation

A self-excited system differs from a forced system in that in the former case there is no excitation when there is no vibration. For self-excitation to be continuously maintained in a dissipative system energy must be extracted from some source and Bishop⁶⁵ describes the combination of attributes that decide whether or not energy can be tapped in this way as the 'dynamical personality' of the system made up by "its principal modes, natural frequencies and dampings".

Each problem in self-excitation requires detailed analysis to reveal the facets that go to make up the 'personality' of the system and in this thesis an attempt has been made to lay bare some of the 'personality traits' of overflowing nappes.

Bishop states further that it is not always - nor indeed usually - sufficient to regard self-excitation as simply the nullification of damping. "In effect," he states "mass and stiffness changes can also occur." This may come about by a delay mechanism as outlined in section 7.2 or as a result of the influence of the external forces on the free vibration characteristics of the system.

9.2 The 'dynamical personality' of nappes

If one accepts the fact that a nappe system, being a continuous train of elements, can tune itself to any frequency and that the number of wavelengths contained in an oscillating nappe can be an integer plus one quarter then it becomes clear that, because of the existence of the phase difference of a quarter cycle between the applied force and the displacement near the origin, the transverse motion of the nappe as a whole is stimulated and it follows that the amplitude would increase indefinitely were it not for the fact that splitting of the nappe where it is thinnest limits the amplitude. The unstable system becomes quasi-stable when the energy input per cycle becomes equal to the energy dissipated per cycle.

The actual frequency which obtains must be such that when multiplied by the time of fall the product equals an integer plus one quarter.

Because the spread of the nappe elements varies inversely as the frequency it becomes evident that insufficient gain would be achieved with frequencies that were either too high (because the change in volume on the enclosed side of the nappe would become negligible) or too low (because the nappe would be inclined to split as the length of the last quarter wave and its amplitude increased).

The limiting case of a steady-state nappe may be looked upon as a nappe undergoing oscillation with infinite frequency and zero amplitude.

There exists thus a range of possible frequencies controlled by an intricate inter-relationship among the following factors: the pressure transmitted despite leakage, the initial thickness of nappe, height of fall and associated delay, angle of projection and volume of trapped air. All these facets together go to make up the 'dynamical personality' of the system. A simplified description of the mode of action of the oscillation must suffice until more sophisticated instrumentation can be designed and built than is at present available for the purpose of measuring accurately the rapidly varying pressures and amplitudes of oscillating nappes. Further progress can be made when the wave form generated by the pressures can be analysed and the harmonics generated explicitly defined.

The adage that 'nature is not afraid of analytical difficulties' is particularly applicable to nappe oscillation and the intricacies of the various types of non-linearity involved in the mechanism of operation seem at this stage to preclude a complete solution to this obscure phenomenon. It would appear, however, that by considering the motion 'in-the-small' and by using linear

approximations it may be possible to decide whether or not a particular nappe would be subject to instability.

In particular, it would be an almost impossible task to establish accurately the leakage characteristics and associated pneumatic stiffness of the dynamic system. Also, as pointed out by Glover et al¹⁰, the existence of side-walls makes it difficult to obtain a cinematographic record of a two-dimensional nappe profile. High speed photography was tried by the Author without conspicuous success. Indirect evidence can, however, be obtained by photographing a three-dimensional nappe (i.e. a water bell) undergoing oscillation. An excellent ciné film of an oscillating water bell was made by Porter²⁰ in the Mechanical Engineering Department of this University and, upon viewing the nappe in slow motion bursting of the water nappe is quite apparent.

9.3 Conclusions and recommendations for further research

In this work it has been established that an oscillating nappe system may be described as a non-linear oscillator in which the nappe acts as a pressure generator and amplifier. A delay is associated with the amplification and because the system is in a resonant condition, the amplitude would increase indefinitely were it not for the limiting action of natural and enforced leakage. The term 'relaxation oscillation' is sometimes applied to phenomena of this nature.

Generally a number of possible frequencies exist in a sequential set of values determined by the criterion that the frequency when multiplied by the time of travel of the water elements must equal an integer plus one quarter. The integer is generally 2, 3, 4 or 5, but occasionally 1, 6, 7, 8, 9, 10, 11, or 12.

Occurrence of the phenomenon on dams can readily be avoided by the introduction of efficient splitters at suitable intervals along the lip of the weir crest and it is recommended from experience on hydraulic models in the laboratory that these be placed not further apart than two-thirds of the fall height. Where the water falls against a steeply graded transverse slope, e.g. the sides of a valley, or where the fall is more than about 150 ft, the provision of splitters becomes unnecessary. Experience has further indicated that the splitters need not be more than about three feet high since nappes discharged under a head of $2\frac{1}{2}$ ft or more do not appear to be capable of oscillation. An effective design of splitter is illustrated in Figure 1.3.

Further research into the fascinating and vexed problem of nappe oscillation could well be directed towards reaching a deeper understanding of the associated edgetone phenomenon. Detailed knowledge of the various dynamic characteristics of the system would undoubtedly clarify

the actual controlling mechanism that establishes which of several possible frequencies the system will automatically adopt. In this connection it seems worthy of note that Richardson⁶⁶ has suggested that acoustics and hydrodynamics which until the twentieth century were 'scarcely separated' will again be brought together.

Full knowledge of the system characteristics would also lead to a situation where the interpretation of model behaviour would be placed on a more realistic basis than is at present the case.

Research could also profitably be directed towards determination of the effect of boundary layer instability on the preferred frequency of the system as it is known that roughening of the weir crest markedly alters the nappe trajectory and reduces the likelihood that oscillations will be self-sustaining. Experimental verification of the 'leakage' theory would also be of value in establishing pneumatic stiffness characteristics.

There seems little doubt that as suggested by Nyborg⁴⁷ advances in other fields, perhaps quite remote from nappe oscillation, will follow from advances in knowledge of this curious and fascinating phenomenon. For example, flame stabilization in rocket combustion chambers and turbojets appears to be a field of considerable

conjecture^{67,68} and development of flame-burning devices might well be advanced by application of some of the principles established in this thesis. The present state of knowledge of non-linear control was admirably reported on by Ku⁶⁹ who gives 99 references. Nevertheless, it is clear from Ku's work that, despite advances in recent years, much remains to be done in this field of endeavour.

The outcome of almost any research project is quite unpredictable and in this study it has been remarkable how many apparently diverse fields of knowledge have been drawn upon. It is hoped that the findings of the study will in turn prove of value not only to hydraulicians but also to researchers in other spheres.

A P P E N D I X 1

NOTATION

CHAPTER II - Sections 2.4 to 2.9

b	=	length of weir
Q	=	total discharge along length of weir
q	=	discharge per unit length of weir
h	=	thickness of nappe
v	=	nappe velocity as section considered
v_0	=	initial velocity
g	=	gravitational acceleration
ϕ	=	angle of nappe with x axis
ϕ_0	=	initial angle of projection
δs	=	length of element of nappe along direction of flow
σ	=	surface energy
γ	=	specific weight of fluid
P	=	outer air pressure
p	=	inner air pressure
R	=	radius of curvature
K	=	curvature
θ	=	half angle subtended by incremental arc
y'	=	$\frac{dy}{dx}$
y''	=	$\frac{d^2y}{dx^2}$

CHAPTER II - Sections 2.10 and 2.11

- a = pressure factor, $\frac{P - p}{\gamma h_0}$
- c = square of Froude number
- g = gravitational acceleration
- h_0 = initial thickness of nappe
- P = outer air pressure
- p = air pressure beneath nappe
- t = time
- V_0 = initial velocity
- γ = specific weight of liquid
- θ = angle of tangent to nappe to y- axis
- θ_0 = initial angle of projection to y-axis
- α = arctan $\frac{a \sin \theta_0}{a \cos \theta_0 + 1}$

CHAPTER III

- ω = angular velocity
- F = steady transverse pressure
- P = peak value of sinusoidally varying transverse pressure
- α = pressure factor $\frac{F + P \cos (\omega t) b}{QV_0}$

CHAPTER IV

- K = an integer
- H = height of fall

CHAPTER V

- F = driving force
- d = damping force
- y = displacement
- λ = length of lowest quarter wave
- A_0 = maximum displacement
- B = maximum value of force
- \dot{y} = $\frac{dy}{dt}$

CHAPTER VI

- A = cross-sectional area of cylinder
- α = orifice area
- B = maximum amplitude
- n = unit mass of air
- v = specific volume in terms of mass
- t = time
- \dot{m} = $\frac{dm}{dt}$
- p = pressure
- C = constant
- K = adiabatic exponent
- ρ = mass density
- ω = angular velocity

CHAPTER VII

- Q = natural damping coefficient
- N = applied damping coefficient

P = restoration coefficient

h and k are time lags

\dot{X} is derivative of X with respect to time

\ddot{X} is derivative of \dot{X} with respect to time

τ = lag period

$e(t)$ denotes a voltage; the argument at which the term is evaluated is denoted by the subscript in brackets.

C = constant

G = gain

p and q are constants used in describing the limiter characteristics

K = an integer

CHAPTER XIII

p = instantaneous pressure

F = peak value of pressure

q = unit discharge

ρ = mass density of jet

L = distance from slit to wedge

t = time

T_1 and T_2 are specific times

V_0 = jet velocity

K = an integer

λ = wave length

APPENDIX II

TYPICAL FORTRAN PROGRAM FOR COMPUTER

```

1 PRINT 2
2 FORMAT(40HF1, Q, V, DELTS, P, TIME, CYCLE, F)
ACCEPT 3,F1,Q,V,DELTS,P,TIME,CYCLE,F
3 FORMAT(F6.1,F6.3,F6.2,F7.4,F8.3,F7.5,F7.2,F7.4)
SPRNT=0.
X=0.
Y=0.
S=0.
VE=V
OMEGA=2.*3.1415926*CYCLE
F1=F1/57.296
B=0.01/(Q*V)
D=62.4/32.2
U=V*V/64.4
VOL=0.
4 IF(SENSE SWITCH 1)1,5
5 ESINC=0.1
IF(SENSE SWITCH 2)6,7
6 ESINC=0.01
7 IF(SENSE SWITCH 3)8,9
8 DELTS=0.01
9 IF(SENSE SWITCH 4)10,11
10 ESINC=0.4
11 E=SQRT(1.+Y/U)
RNUME=D*E-B
A=P*COS(OMEGA*TIME)/(Q*V)
RDENO=A+D*COS(FI)/(2.*E*U)
R=RNUME/RDENO
THETA=DELTS/(2.*R)
VEL=E*V
VI=FI*57.296
C=F*Y*COS(OMEGA*TIME+3.1415926)/3.25
XC=X+C
IF(S-SPRNT)14,12,12
12 PRINT 13,X,Y,R,VI,VEL,TIME,VOL,XC
13 FORMAT(F7.4,F8.4,2X,E9.3,F7.2,F8.3,F9.4,F9.4,F8.4)
SPRNT=SPRNT+ESINC
14 DELTX=2.*R*SIN(THETA)*COS(FI+THETA)
DELT Y=2.*R*SIN(THETA)*SIN(FI+THETA)
DETIM=2.*DELTS/(VE+VEL)
VE=VEL
TIME=TIME+DETIM
X=X+DELT X
Y=Y+DELT Y
S=S+DELTS
DEVOL=X*DELT Y
VOL=VOL+DEVOL
FI=FI+2.*THETA
IF(Y-4.5)4,4,1
END

```

SYMBOLS USED IN COMPUTER PROGRAM

FI	---	Angle of projection measured downward from horizontal axis
Q	---	Discharge per unit length of weir
V	---	Initial velocity
DELTS	---	Increment along trajectory
P	---	Transverse pressure
TIME	---	Time
CYCLE	---	Frequency
F	---	Lateral adjustment
R	---	Radius of curvature
VI	---	Angle of path to horizontal axis
VEL	---	Instantaneous velocity
VOL	---	Volume of space between nappe trajec- tory and vertical axis

REFERENCES

1. Guha, S.K. and Luthra, S.D.L., "Hydro-elastic vibrations for dams." Proc. 10th Gen. Mtg., Intern. Assoc. Hydraulic Res., London. Vol. 3 (1963) pp 201 - 212.
2. Campbell, Frank B. "Vibration problems in hydraulic structures." Trans. Amer. Soc. civ. Eng. Vol. 127 (1962) pp 1 - 17.
3. Fuhrmann, O., "Schwingungsuntersuchungen und überströmten beweglichen Wehren." Berlin (1934).
4. Pariset, E. "Étude sur la vibration des lames déversantes." Proc. 6th Gen. Mtg. Intern. Assoc. Hydraulic Res., The Hague (1955).
5. Müller, O., "Das bei Überfall schwingende Wehr als selfsterregtes, gekoppeltes System unter Berücksichtigung gewisser Analogien zum Röhrensender und zur Zungenpfeife." Mitt. Preuss. Ver. Wasserbau und Schiffbau, No. 33, Berlin (1937).
6. Petrikat, K., "Vibration tests on weirs and bottom gates." Water Power, Vol. 10 (1958) pp 52 - 57, 99 - 104, 147 - 148 and 190 - 197.
7. Seifert, R., "Über Schwingungen von Wehren." V. dtsh Ing. Vol. 84, No. 7 (February 1940) pp 105 - 110.

8. Fischer, H., "Die Schwingungen an überstromten Wehren und ihre Beseitigung." Z. Ver. dtsh Ing. Vol. 82, No. 1 (January 1938) pp 27 - 28.
9. Peters, K., 'Mitteilungen des Hydraulischen.' Inst. der Tech. Hochschule - München (1940).
10. Glover, R.E., Thomas, C.W. and Hammett, T.F., "Report on vibration studies made at black canyon dam Boise project." Report Hyd-58 U.S. Bur. of Reclamation, Denver (1939).
(Note work also reported in ref. 16).
11. Leo, B., "Self-excited vibrations at overflow weirs." U.S. Waterways Expt. Stn. Translation No. 55-6, Vicksburg, Miss., June 1955. Original in Veröffentlichungen der Forschungsanstalt für Schifffahrt, Wasser und Grundbau, No. 3 (1954).
12. Midgley, D.C., Report of model investigation to Consulting Engineers (1960). Unpublished.
13. Carman, A., "Report on vibrating nappe." Dept. of Civil Engineering, Univ. of the Witwatersrand, Johannesburg (1961). Unpublished.
14. Kemp, A.R. and Pullen, R.A., "Report on vibrating nappe phenomenon." Dept. of Civil Engineering, Univ. of the Witwatersrand, Johannesburg (1961). Unpublished.

15. Rigard, J., "Etude en laboratoire de le vibration des lames déversantes." Soc. Hydr. de France, 8th Congr., Lille (1964) Report No. 10.
16. Simmons, Walter P., "Experiments with flow-induced vibrations." Jour. of the Hyd. Divn. Proc ASCE, Vol. 91 (1965) pp 185 - 204.
17. Schwartz, H.I., "Some observations on models of oscillating nappes." Trans. S. Afr. Instn. Civ. Engrs. Vol. 4 (July 1962) pp 138 - 139.
18. Blaisdell, Fred W., "Equation of the free-falling nappe." Proc ASCE Vol. 80., separate No. 482 (August, 1954).
19. Woronetz, C., "Sur la forme de la nappe des deversoirs sans aerage." Comptes Rendus de l' Academie des Sciences, Vol. 238 (Apr. 1954) pp 1688 - 1690.
20. Porter, N., "A study of the flapping phenomenon exhibited by water bells." Laboratory report to Dept. of Mech. Eng. Univ. of the Witwatersrand, Johannesburg. (1963). Unpublished.
21. Savart, F., Ann. Chim. Phys. Vol. 54 (1833) p 55, Ibid Vol. 55 (1834) p 257.
22. Hopwood, F.L., "Water bells." Proc. Phys. Soc. (B) Vol. 64 (1952) pp 2 - 5.

23. Boussinesq, J., Comptes Rendus Acad. Sci., Paris, Vol. 69 (1869) pp 45 - 48 and 128 - 131. Ibid, Vol. 157 (1913) pp 89 - 94.
24. Lance, G.N. and Perry R.L., "Water bells." Proc. Phys. Soc. (B) Vol. 66 (1953) pp 1067 - 1072 and plate between pp 1128 and 1129.
25. Lance G.N. and Deland E.C., Letter to editor, Proc. Phys. Soc. (B) Vol. 68 (1955) pp 54 - 55.
26. Schwartz, H.I., "A study of a two-dimensional nappe of projected liquid." Trans. S. Afr. Instn. of Civ. Engrs. Vol. 5 (1963) pp 6 - 11.
27. Kilner, F.A., Discussion on paper, ref. 26 Trans. S. Afr. Instn. of Civ. Engrs. (July 1963) pp 209 - 210. See also (August 1963) p 239.
28. Schwartz, H.I. and Nutt, L.P., "Projected nappes subject to transverse pressure." J. Hyd. Div., Proc. ASCE Vol. 89 (July 1963) pp 97 - 104.
29. Lance, G.N., and Deland E.C., "The shape of the nappe of a thin waterfall." Quart. J. Mech. and Applied Math. Vol. IX Pt. 4 (1956) pp 394 - 399.
30. Schwartz, H.I., "Projected nappes subject to harmonic pressures." Proc. Instn. civ. Engrs. London (July 1964) pp 313 - 326.

31. Schwartz, H.I., "A contribution to the study of nappe oscillation." Trans. S. Afr. Instn. civ. Engrs. Vol. 5 (1963) pp 253 - 254.
32. Feather, N.I., "An introduction to the physics of vibrations and waves." Edinburgh Univ. Press. Edinburgh (1961) p 121.
33. Schwartz, H.I., "Nappe oscillation." J. Hyd. Div., Proc. ASCE, Vol. 90 (November, 1964) pp 129 - 143.
34. Bellman R., and Cooke, K.L., "Differential-difference equations." Academic Press. New York (1963).
35. Minorsky, N., "Control problems." Journal of the Franklin Institute, Vol. 232, Part 2 (1941) pp 451 - 487 and 519 - 551.
36. Volterra, E., "Vibration of elastic systems having hereditary characteristics." J. app. Mech. Vol. 17 (1950) pp 363 - 371.
37. Bateman, H., "The control of an elastic fluid," Bull. Amer. Math. Soc. Vol. 51 (1945) pp 601 - 646.
38. Minorsky, N., "Self-excited oscillations in dynamical systems possessing retarded action." J. app. Mech. ASME Vol. 64 (1942) A65-A71.
39. Poritsky, H., Discussion on ref. 38. Ibid pp A195-A196.

40. Collatz, L., "Über Stabilität von Regelungen mit Nachlaufzeit." Z. Angew Math. Mech. Vol. 25/27 No. 2 (May 1947) pp 60 - 63.
41. Editorial Staff, "The principles and practice of automatic control." The Engineer, Vol. 163 (1937) p 439.
42. Pipes, Louis A., "The analysis of retarded systems." J. app. Phys. Vol. 19 (July 1948) pp 617 - 623.
43. Cunningham, W.J., "Introduction to non-linear analysis." McGraw Hill, New York (1958) p 230.
44. Schwartz, H.I., Closure to paper ref. 33 J. Hyd. Div., Proc. ASCE., Vol. 92 (Jan. 1966) pp 82 - 85.
45. Naudascher, E., Discussion on paper ref. 33 J. Hyd. Div., Proc. ASCE., Vol. 91 (May 1965) pp 389 - 392.
46. Petrikat, K., and Unny, T.E., Discussion on ref. 33, J. Hyd. Div., Proc. ASCE., Vol. 91 (Sept. 1965) pp 223 - 229.
47. Nyborg, Wesley L., "Self-maintained oscillations of the jet in a jet-edge system. I." J. Acoust. Soc. Am., Vol. 26 (1954) pp 174 - 182.
48. Powell, A., "On the edgetone." J. Acoust. Soc. Am., Vol. 33 (1961) pp 395 - 409.

49. Masson, A., Comptes Rendus Vol. 36 (1853) pp 257
and 1004.
50. Sondhaus, C., Ann. Phys. Lpz. Vol. 91 (1854) pp 128
and 214.
51. Helmholtz, H. von., Proc. Acad. Sci. Berlin (1868).
52. Wachsmuth, R., Ann. Phys. Lpz., Vol. 14 (1904) p 469.
53. König, W., Phys. Zeits. Vol. 13 (1912) p 1053.
54. Schmidtke, E., Ann. Phys. Lpz., Vol. 60 (1919) p 715.
55. Lenihan, J.M.A. and Richardson E.G., "Observations
on edge tones." Phil. Mag., Vol. 29 (1940) pp 400 -
406.
56. Brown, G. Burniston, "The vortex motion causing edge
tones." Proc. Phys. Soc., London. Vol. 49 (1937)
493 - 507.
57. Brown, G. Burniston, "The mechanism of edge-tone
production." Proc. Phys. Soc., London. Vol. 49
(1937) pp 508 - 521.
58. Curle, N. "The mechanics of edge-tones." Proc. Roy.
Soc., London A Vol. 216, (1953) pp 412 - 424.
59. Gross, M.J., "Underwater edge tones." Acustica Vol.
9 (1959) pp 164 - 172.

60. Richardson, E.G., "Sound." Arnold, London (1929).
61. Schwartz, H.I., "Edgetones and nappe oscillation." J. Acoust. Soc. Am., Vol. 39 (1966) pp 579 - 582.
62. Albertson, M.L., Dai Y.B., Jensen, R.A., and Rouse, Hunter, "Diffusion of submerged jets." Trans. ASCE., Vol. 115 (1950) pp 639 - 664.
63. Chanaud R.C., and Alan Powell, "Experiments concerning the sound-sensitive jet." J. Acoust. Soc. Am., Vol. 34 (1962).
64. Powell, Alan., "Aspects of edgetone experiment and theory." J. Acoust. Soc. of Amer., Vol. 37 (1965) pp 535 - 536.
65. Bishop, R.E.D., "Vibration." Cambridge Univ. Press. Cambridge (1965) p 64.
66. Richardson E.G., "Relations between acoustics and hydrodynamics." J. Acoust. Soc. Am., Vol. 26, No. 5 (1954) pp 615 - 617.
67. Putman, A.A., and Dennis, W.R., "A study of burner oscillations of the organ-pipe type." Trans. ASME., Vol. 75 (1953) pp 15 - 25. (See also discussion on pp 27 and 28).

68. Kaskan W.E. and Noreen A.E., "High-frequency oscillations of a flame held by a bluff body." Trans. ASME., Vol. 77 (1953) pp 885 - 895.
69. Ku, Y.U., "Theory of non-linear control." Proc. First Cong., Intern. Fedn. of Automatic Control (I.F.A.C.): Butterworths, London (1963).