

punching shear collapse load plotted relative to  $a/d$  ratio. The major influences on this function in this regard are the increase in resistant shear stress with reduction in  $a/d$  ratio, the reduction in available perimeter with reducing  $a/d$  ratio, and the reduction in load which can be deducted from the total load precipitating shear failure with reducing  $a/d$  ratio. This evaluation of the test data of the previous sections results in the curved functions indicated in Figure 4.10. Where these functions give results which are lower than the recommendations of the draft code BS0000, this has been highlighted by vertical hatching of the difference. For the span/depth ratio of 5 there is thus a direct transfer of results from Figure 4.9 to Figure 4.10. It is also evident that there is an approximate coincidence of the minima for the test results and the recommendations of the draft code as the span/depth ratio approaches 7.

The circumstances related to this particular silo floor case study are likely to be relatively rare and it is thus evident that the column face check will suffice in almost all situations. It is of note that the trends depicted in Figure 4.10 are the results of the combined effects of depth and span/depth ratio of the case study under consideration, and are obtained from the consideration of the minimising of the collapse load function for punching shear, considering in particular the variation of resistant shear stress with the independent variable,  $a/d$  ratio. The variation in applied shear force at ultimate with changes in true size of the punching cone also has a major influence on the collapse load function.

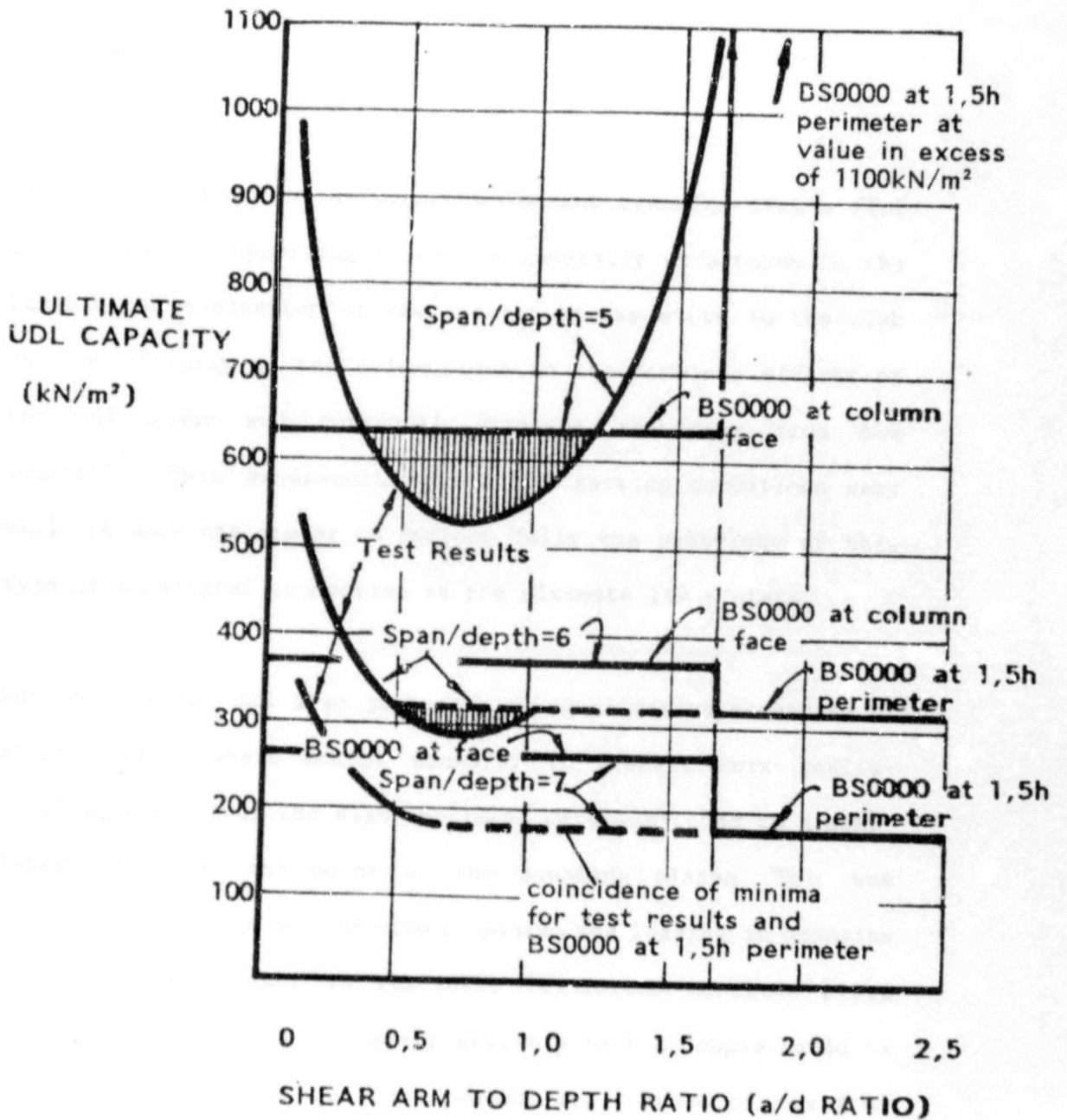

FIGURE 4.10

VARIATION OF ULTIMATE DESIGN UNIFORMLY DISTRIBUTED LOAD CAPACITY FOR 1200mm DEEP SLAB WITH  $a/d$  RATIO, FOR DIFFERENT SPAN/DEPTH RATIOS.

#### 4.5 MOMENT TRANSFER

The assessment of the influence of moment transfer from a flat plate into a supporting column is generally undertaken on the basis of an evaluation of the elastic stress state in the slab in the vicinity of the column, due to the combined effects of vertical shear and torsional stresses resulting from the moments<sup>37</sup>. This assessment models the service conditions very well but does not appear to reflect fully the behaviour of this type of structural connection at the ultimate limit state.

For this reason and also to assess the qualitative mechanism of shear failure where moment transfer is present more realistically, certain of the slab specimens were subjected to a simulated couple at the point of the punching platen. This was achieved by using a reduced size of platen and loading in opposite senses. It is evident in realistic reinforced concrete plate structures that it is extremely unlikely that a couple could be applied to a slab without simultaneous application of vertical load onto the supporting column. The manner in which the vertical load would be combined with the couple in the column is indicated in Figure 4.11 and the tests were conceived on this basis. The transfer of moment from the slab to the support column is dependent to some extent on the presence of vertical column re-

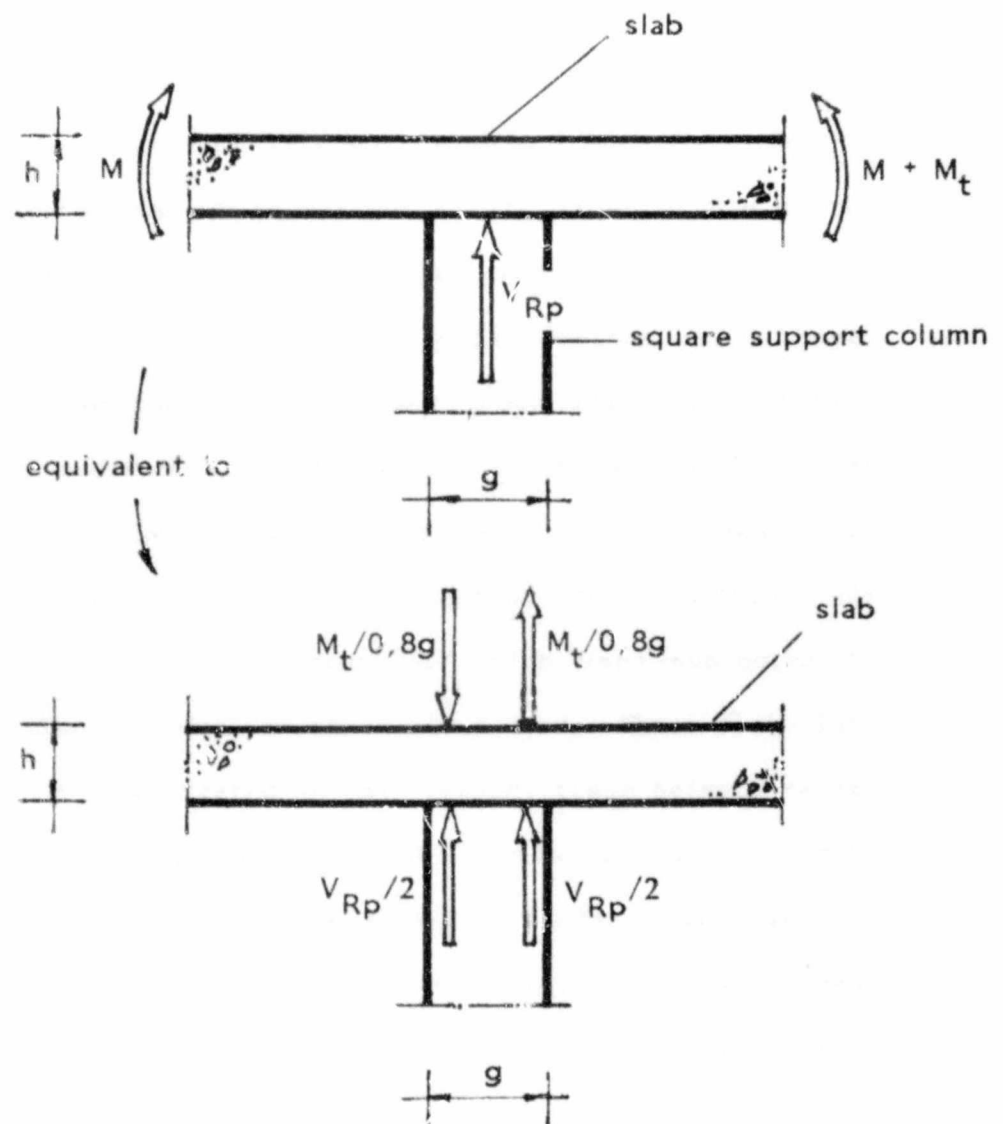

FIGURE 4.11 SKETCH SHOWING LOADING CONDITIONS AT THE ULTIMATE LIMIT STATE IN PUNCHING SHEAR FOR FLAT PLATE STRUCTURES SUBJECTED TO TRANSFER OF MOMENT AT THE SUPPORT COLUMN.

inforcement, particularly if the column does not extend above the floor under consideration. For this reason, the lever arm of the couple inducing this moment transfer is assessed as being approximately the dimension between the main column bars. For an average square column, this will be of the order of 0.8 of the lateral dimension of the column. The even distribution of the column reaction without the moment couple application is based on the assumption that flexural cracking and load redistribution will usually occur over the column head at a considerably lower load than that of the ultimate limit state of punching shear. This assumption is based on observations on prototype structures, either completed or under construction, which were subjected to loads less than or equal to the service loads. Three flat plate structures were investigated in this regard, these being a reservoir roof, a parking garage suspended floor and an office building floor. All were found to have flexural cracks in the vicinity of the column supports under the effect of primarily service dead load only. The extent and magnitude of this flexural cracking increased as the design dead to imposed load ratio for the structure increased. The extent of this flexural cracking at the serviceability limit state is not particularly relevant, but it is clear from the examination of these structures that cracking and load redistribution will generally have occurred prior to the attainment of the ultimate limit state of punching shear.

The test results confirm that the mode of shear failure will generally remain one of punching shear, with the only fundamental change being that the punching platen is effectively reduced in size and subjected to an increased vertical load due to the presence of the couple. Whereas the test results on corbels, where high moments and shears exist in close proximity, indicated that there was no significant ultimate moment-ultimate shear interaction, the simplistic tests undertaken on the slab specimens indicate that moment transfer might influence punching shear performance. The philosophical justification for this divergence in concept is based on the principle that the applied shear in beam elements is a "shear-in-span" phenomenon (specifically in the zone of the shear arm), whereas the applied shear in punching shear evaluation is a "total reaction" phenomenon at the support (column). It is, however, accepted that this is an area requiring further tests on specimens subjected to pure bending before the influence of moment transfer can be assessed at the ultimate limit state in detail.

Another significant mode of failure which occurred in these test specimens and which could realistically occur in practice was that of an inverted fan yield-line flexural failure where there is an absence of adequate bottom steel in the vicinity of the column support. If the slab is not reinforced in this zone this mode of failure will also be non-ductile and the occurrence of this mode of failure is considered to be of greater concern than

reductions in specific punching shear capacity of the slab, but fortunately only occurs at very high moment to column reaction ratios, which are unlikely to occur in practice.

Nevertheless, based on an evaluation of the loading at the ultimate limit state as indicated in Figure 4.11, and on the observed punching failures that occur at ultimate, a set of transfer moment-ultimate shear (or ultimate reaction more correctly) interaction curves have been developed as indicated in Figure 4.12. These interaction curves have thus been derived from the test results of this chapter, and therefore in this figure:

$M_t$  = transfer moment. (N mm)

$V_{Rp}$  = mean ultimate resistant punching shear. (N)

$h$  = overall slab depth. (mm)

$g$  = lateral dimension of square support column. (mm)

$v_R$  = total mean ultimate resistant shear stress  
obtained from test results. (MPa)

These interaction curves indicate that in general there is a range of transferred moment for which reduction in resistant punching shear capacity might not be required. This is somewhat in con-

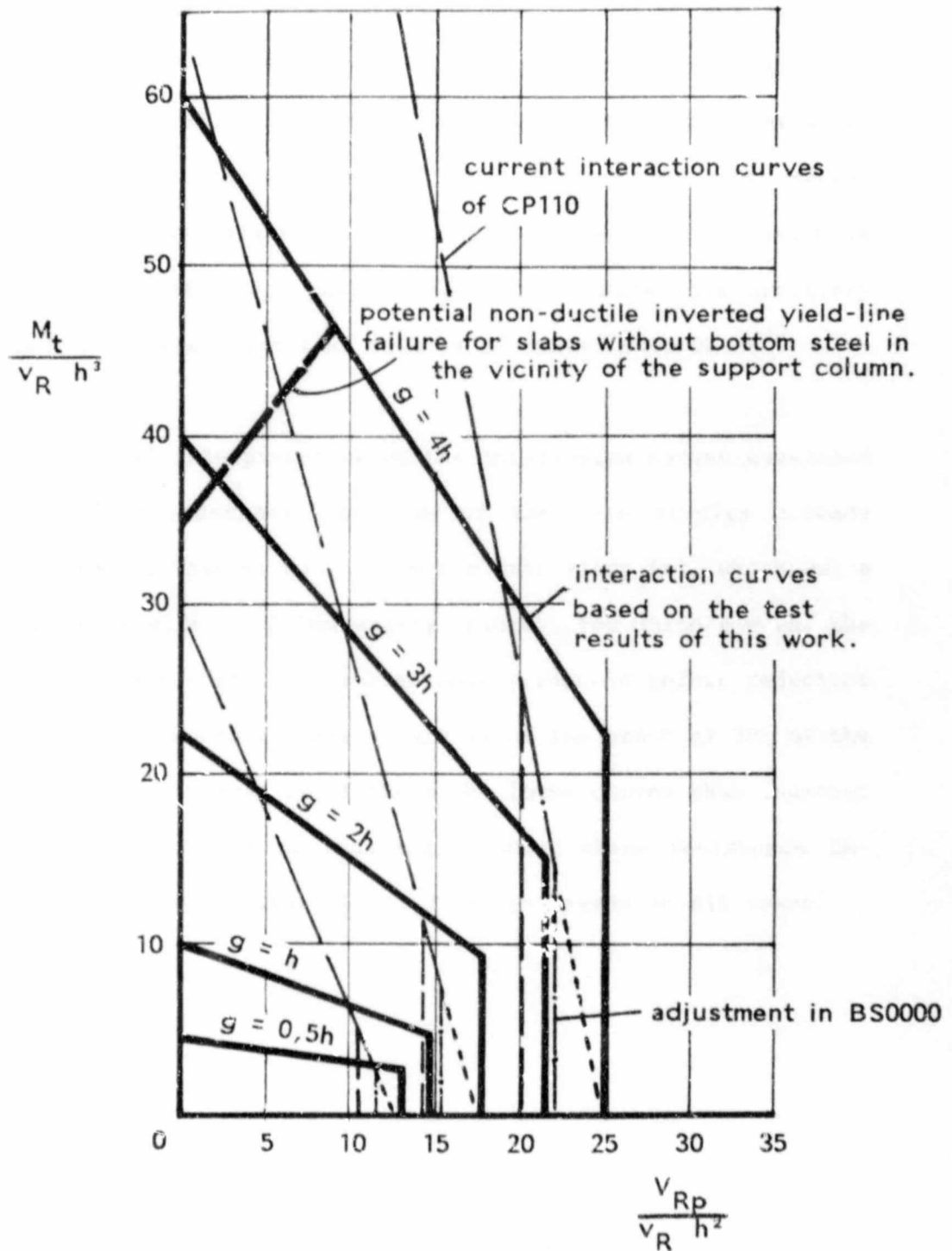

FIGURE 4.12 ULTIMATE PUNCHING SHEAR-TRANSFER MOMENT INTERACTION CURVES FOR TYPICAL FLAT PLATE REINFORCED CONCRETE STRUCTURES.

trast to the current moment-shear interaction equation applicable to CP110, which are also shown on the same axes. The implication of these test results is that the arbitrary reduction in resistant punching shear capacity for all flat plate structures, recommended by CP110, might not be fully justified. This result is consistent with the trend in BS0000 to reduce this arbitrary penalty, and also with test results of other researchers<sup>30</sup>.

The practical interpretation of the interaction curves developed here is best undertaken in terms of the case studies already considered in Chapter 4.4. Thus for case study (a), which was a 150mm thick slab on 300mm square columns, for which  $g = 2h$ , the curves predict that the transfer moment reached before reduction in resistant punching shear occurs is of the order of 30% of the ultimate moment capacity of the slab. These curves thus indicate that the requirement of reducing punching shear resistance because of moment transfer might not be necessary in all cases.

#### 4.6 REINFORCING SLABS FOR SHEAR

All the test results and comparative analyses pertaining to the phenomena discussed in Chapters 4.3 to 4.5 refer essentially to specimens unreinforced for shear. Thus the specimens considered all relied specifically on the contribution to shear resistance capacity of flexural reinforcement only, together with the other parameters affecting the maximum shear stress where appropriate.

A number of slab specimens reinforced for shear with a horizontal layer of reinforcement at mid-depth of the slab were also tested. The performance of vertical links is generally well documented for beam elements, but they are rather difficult to fix in slabs and are also reported as not being particularly effective for slabs thinner than about 200mm. These observations, together with the observed influence of horizontal links in corbels, prompted the investigation into the use of a horizontal layer of isotropic reinforcement in the slabs at mid-height as shear reinforcement. For slabs up to 200mm thick, the inclusion of this reinforcement appeared to enhance the shear resistance rather marginally, particularly for unconstrained punching cone modes of failure. The shear failure mode was non-ductile. The test results for these slabs are tabulated in Appendix B, where the (horizontal) shear reinforcement ratio is denoted by the symbol

μ. The observed rather poor performance of this type of shear reinforcement, particularly for unconstrained punching failures, is not inconsistent with code recommendations<sup>5,13</sup> that shear link reinforcement is neither practical nor particularly effective in slabs thinner than 200mm, and is also consistent with the universal model for shear developed in Chapter 8. As the slab depth increased and the  $a/d$  ratio reduced, this form of horizontal shear reinforcement appeared to show a consistent improvement in the enhancement of the peak punching shear resistance. This trend is evident in Appendix B and is also predicted by the proposed universal model for shear. Although enhanced, the shear failure mode remained distinctly non-ductile. The implications of these simplified tests are that this form of reinforcement could have wide application in deep slabs, pilecaps and other similar structures, where shear resistance needs to be increased to a value greater than the flexural capacity of the structure. The development of a universal model for shear which could quantify the performance of such reinforcement for this variety of structural situations is obviously highly desirable.

## 4.7 EVALUATION OF PRESTRESSED SLABS

Owing to the increased use of post-tensioned flat plate structures and also to determine the parametric trends for prestressed elements in general, a series of tests on post-tensioned slabs was undertaken. The objectives of the test series on the prestressed slab elements were thus to qualify and quantify the parametric trends of the resistant punching shear stress for prestressed slabs but also specifically to consider the influence if any at the ultimate limit state in shear of leaving the post-tensioning bars unbonded for the tests.

### 4.7.1 DESCRIPTION OF THE SPECIMENS

Geometrically, the prestressed slab specimens were similar to the ordinary reinforced concrete specimens evaluated in Chapter 4.2. These were thus again 600mm by 600mm in plan and depths of 100mm and 150mm were considered. All the slabs had a mean cube strength at the time of testing of approximately 30MPa. The specimens were prestressed using a post-tensioning system of high yield bars, of ultimate tensile stress approximately 900MPa, passing through

preformed ducts in the slab. A hydraulic jacking system and an appropriate bridge were designed for the prestressing operation. Load in the prestressing bars was monitored using an annular load cell which passed over the bar. The load cell was designed and calibrated for this specific application. As a check and also to monitor load more rapidly, a conventional dynamometer was included in the hydraulic system. The prestressing operation is shown in Figure 4.13. The load cell on the prestressing bars enabled losses after lock-off to be monitored and the net biaxial prestress in the slab at the time of test could thus be assessed reasonably accurately.

#### 4.7.2 DESCRIPTION OF THE TESTS

Once the slab specimens were biaxially prestressed, they were subjected to punching shear load in a hydraulic testing machine through a punching platen in a manner identical to that for the ordinary reinforced concrete slab specimens. The line support was also identical to that described in Chapter 4.2, and is positioned beneath the specimen shown in the general view of a test in Figure 4.14. Grade of concrete was not varied as a parameter in this test series, as its influence on resistant shear stress was assumed to be well documented<sup>5,10,11,13</sup>. The applied biaxial

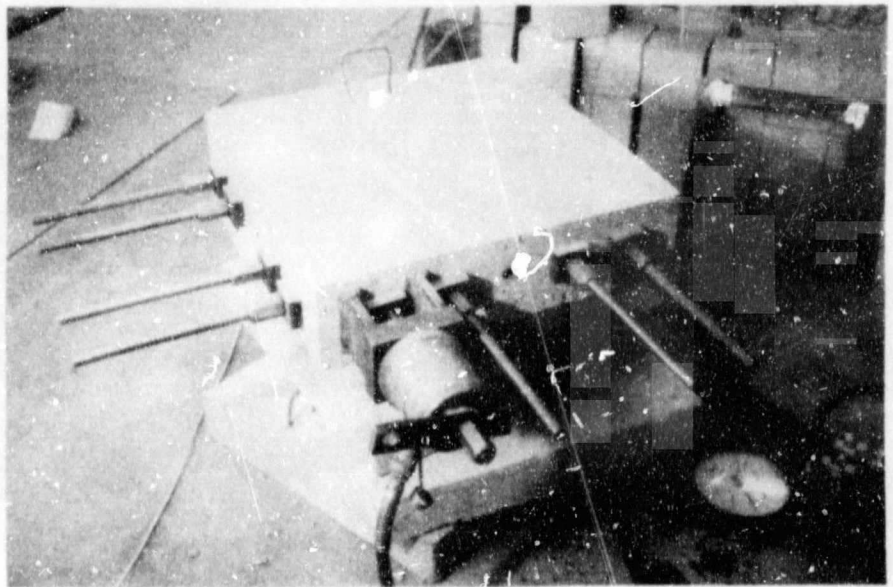

FIGURE 4.13      PHOTOGRAPH SHOWING PRESTRESSING OPERATION  
ON FLAT PLATE SPECIMENS USING HIGH YIELD  
BARS FOR POST-TENSIONING.

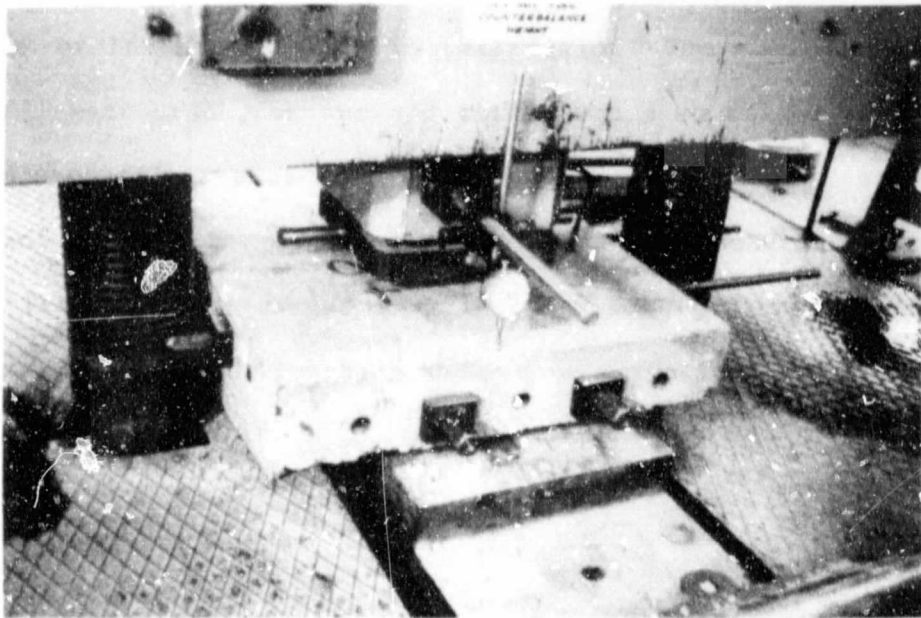

FIGURE 4.14 PHOTOGRAPH SHOWING TESTING OF POST-TENSIONED FLAT PLATE SPECIMENS IN PUNCHING SHEAR.

prestress was varied as a parameter under investigation. Average axial prestress of 0MPa, 3MPa and 6MPa were thus considered, to determine the influence of this parameter on resistant shear stress for prestressed slabs. Depth was also varied to determine its influence on resistant shear stress, but the range of depth was not as great as for the reinforced concrete slab specimens. Overall depths of 100mm and 150mm were tested. An investigation of a wider range of prestressed slab depths is obviously desirable in terms of further research in this field. The slope of the diagonal shear crack, or the  $a/d$  ratio, was also varied to determine the influence of this parameter on the resistant shear stress of the specimens. The  $a/d$  ratios were varied from 1,0 to 2,4 in this test series and thus included both constrained and unconstrained cases of punching shear cone formation at failure.

#### 4.7.3 TEST RESULTS

The control slab specimen with zero prestress and no flexural or shear reinforcement failed in non-ductile, brittle flexure, forming a fan-type pattern resulting from flexural tension stresses exceeding the tension capacity of the concrete. This failure was manifestly not a diagonal shear failure. The slab specimens with axial prestress of 3MPa or more all failed in

classical diagonal punching shear, the test results being given in Table B7 of Appendix B. The parametric trends closely matched those previously observed in the reinforced concrete slab specimens.

Depth remained a parameter affecting resistant shear stress on the punching perimeter, but the test results indicate that the trend might not be as marked for these specimens as for the reinforced concrete slabs. This trend could only be confirmed with considerably more test results. It is clear, however, that depth of section does influence resistant shear stress in punching for prestressed slab elements.

The amount of biaxial prestress present affected the resistant shear stress at a punching perimeter consistent with that used for the evaluation of ordinary reinforced concrete slabs. The design approach for the evaluation of punching shear resistance in the Concrete Society's design handbook for post-tensioned flat slabs<sup>11</sup> relies on the conversion of prestress to an "equivalent" area of ordinary high yield reinforcement. It was thus of interest to note that the enhancement of resistant shear stress with increasing average axial prestress was not significantly different to that for ordinary reinforced specimens for an unconstrained punching perimeter. Doubling the flexural steel ratio for reinforced concrete slabs and doubling the axial service prestress in prestressed slabs both result in an enhancement of 30% to 35%

in the resistant shear stress of the slab at the unconstrained punching perimeter. For an evaluation on the unconstrained punching perimeter, the absolute resistant shear stress values also coincided closely, when using an equivalent area of flexural reinforcement derived on the basis of high yield steel of characteristic strength 410MPa. These observations refer to slabs unreinforced for shear. There is thus some justification for using an approach which converts the prestress to an equivalent area of ordinary flexural reinforcement and then modelling the parametric trends of resistant shear stress on this basis<sup>10,11</sup>, provided that the stress is evaluated on the unconstrained punching perimeter. It is likely, however, that this approach will not generally give similarly consistent results for cases where the punching cone may form more steeply than the unconstrained slope. The universal model for shear developed in Chapter 8 does not make use of the approach outlined above, but rather extends the model for ordinary reinforced concrete in a rational manner. This proposed model appears to predict the general parametric behaviour of prestressed slabs, including the influence of effective  $a/d$  ratio, fairly satisfactorily, as is evident in Appendix B.

The variation in the parameter of  $a/d$  ratio below the value of 2, which coincides approximately with an unconstrained punching perimeter, indicated a clear trend. If the slope of the punching cone, or the slope of the diagonal shear, was reduced signif-

icantly below that of the unconstrained value, then a sharper increase in resistant shear stress was observed in the prestressed specimens than was previously recorded in the reinforced concrete slabs. This trend is indicated in Figure 4.15. The universal model for shear developed in this work predicts these observed phenomena.



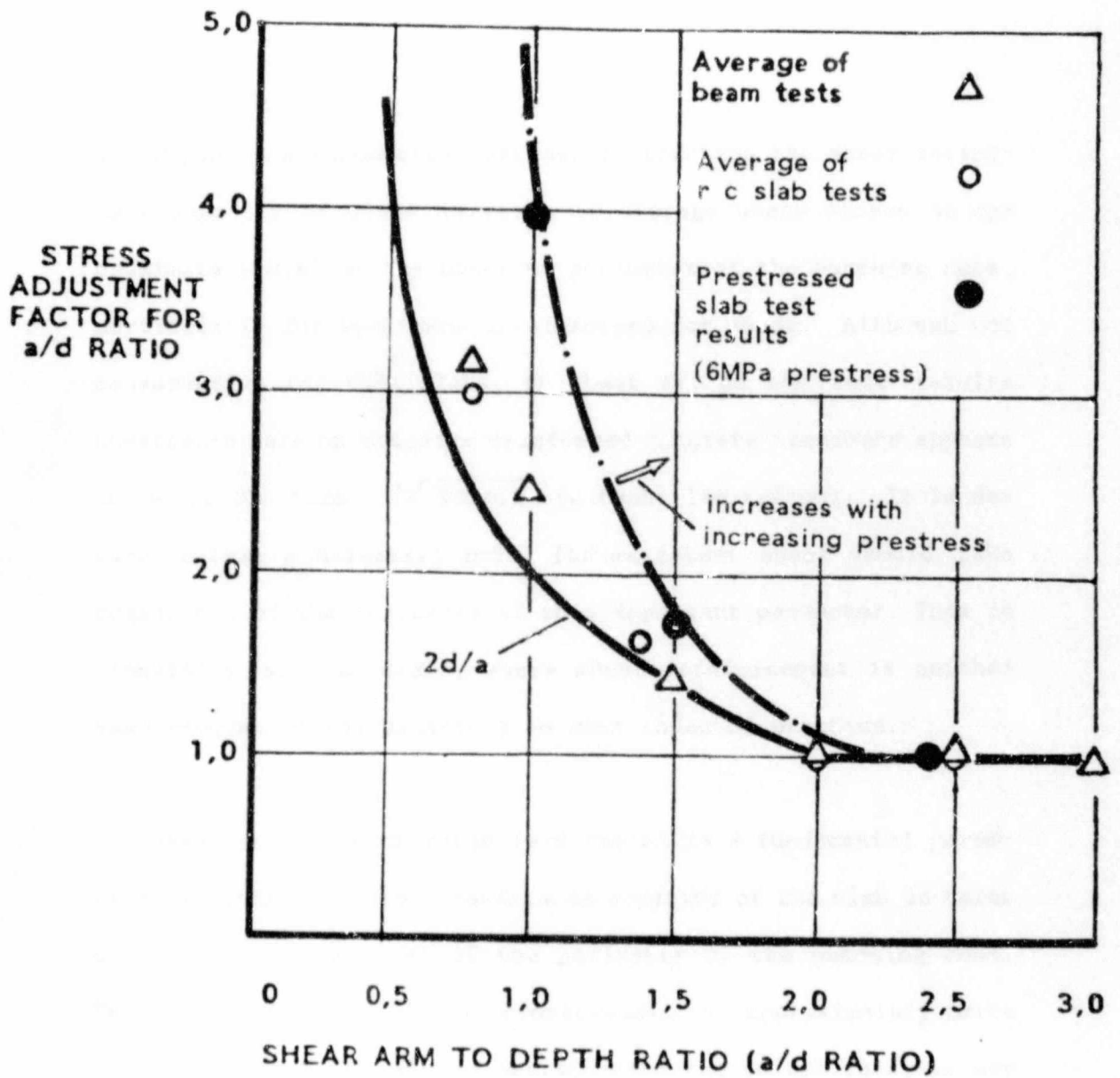

FIGURE 4.15 VARIATION OF ULTIMATE RESISTANT SHEAR STRESS WITH  $a/d$  RATIO (OR SLOPE OF DIAGONAL SHEAR CRACK) FOR PRESTRESSED AND REINFORCED SPECIMENS

#### 4.8 GENERAL CONCLUSIONS FOR FLAT PLATES

1. Depth is a fundamental parameter affecting the shear resistance capacity of slabs in terms of average shear stress at approximately 0,85 of the observed perimeter of the punching cone, particularly for specimens unreinforced for shear. Although not conservative for thin slabs, the best fit to the test results undertaken here on ordinary reinforced concrete specimens appears to be of the form  $\sqrt[3]{(500/d)}$  (without limitation). It is desirable that a universal model for resistant shear should take cognizance of the influence of this important parameter. This is especially so for slabs, where shear reinforcement is neither used frequently nor mandatory in most codes of practice.

2. Shear arm to depth ratio ( $a/d$  ratio) is a fundamental parameter affecting the shear resistance capacity of the slab in terms of shear stress at 0,85 of the perimeter of the punching cone. The perimeter may be either unconstrained, at approximately twice the effective depth of the section from the column face, or may be constrained, at a reduced perimeter. It may also be either full or curtailed by intersection with a free edge. The influence of slope of the punching cone (i.e.  $a/d$  ratio) on resistant shear stress is analogous to the increase in shear resistance in beams where a significant point load is applied in the proximity of the

support. The application to slabs, however, is usually conceptually different. For punching in slabs, the variation in resistant shear stress with changing  $a/d$  ratio, together with variation in applied load with changing dimension of the punching cone, can be used to examine the minimum of the function governing punching shear failure of slabs unreinforced for shear. Another parameter which is likely to have a significant influence in this regard is that of span/depth ratio. This approach to the investigation of the minimum punching shear collapse load will be particularly useful for deep slabs, pilecaps, raft foundations or footings, where although the code perimeter of  $1,5h$  may even project beyond the physical dimensions of the structural element, the probability of shear failure cannot be entirely discounted.

3. Each structural situation must of course be considered on its own merits, but essentially, for cases which warrant special examination, the following shear evaluations should be considered:

- (a) At the unconstrained perimeter, where the diagonal shear crack of the punching cone intersects the flexural reinforcement remote from the compression zone. This coincides very closely with the  $1,5h$  perimeter used in CP110 and BS0000.
- (b) At the column face, using an appropriate enhanced value of resistant shear stress,

acting on a considerably reduced perimeter. This check has been instituted in BS0000 and redresses the potential deficiency of CP110 in this regard. This is effectively a check at an extreme of the function relating  $a/d$  ratio and resistant shear stress.

- (c) Ideally, a check should be carried out between these two extreme points on the curve relating resistant shear stress to  $a/d$  ratio (or slope of the diagonal shear crack or punching cone). A universal model for shear which reflects this parametric relationship is thus also desirable in evaluating this minimum of the collapse load function for punching shear.

4. The influence of grade of concrete on the resistant shear stress of elements unreinforced for shear is significant and reasonably well represented by current codes of practice. A universal model for shear should take the influence of this parameter into account.

5. Variation in flexural steel ratio influences resistant shear stress in punching shear, particularly for elements unreinforced for shear. The variation is reasonably well represented by CP110 and BS0000 and should be included in any model formulation.

Anchorage bond of this flexural reinforcement beyond its point of intersection with the diagonal shear crack (or punching surface) is of fundamental importance.

6. It is of interest to note that the test results indicate that of the four major parameters influencing resistant shear stress of elements unreinforced for shear, grade of concrete possibly has the smallest influence considering the parametric ranges normally encountered in practice. This is somewhat in contrast to traditional code formulations in which resistant shear stress depended only on this parameter.

7. The concepts and principles related to the findings of this series of tests and these case studies can be extended to a variety of other structural applications, such as pad and raft foundations and pile caps. This amplifies the need for a model for shear which will qualify and quantify shear behaviour and performance for this range of specimen types.

8. In reinforcing for shear, cognizance should be taken of the most likely form of the shear crack to develop at the ultimate limit state, visualized on the basis of the above recommendations. The shear reinforcement should then be arranged so that it is most effective within the constraints of practical detailing. This will generally imply horizontal link reinforcement for shear cracks having  $a/d$  ratios of less than unity and vertical

links for shear cracks of  $a/d$  ratio greater than unity. A universal model for shear should aid in this qualitative assessment of potential shear failure for this range of structural types. The shear reinforcement performance should also be quantified by the model for this wide variety of shear failure modes in various structural types.

9. For many cases in practice reflecting reasonable ratios between applied reaction at a column and the estimated moment transfer, the reduction in punching shear capacity with normally encountered transfer of moment does not appear to be warranted. The reduction in punching shear capacity can be severe for large moments, but this situation is not always encountered in practice.

10. The parametric trends observed in ordinary reinforced concrete slab specimens also appear to be present to varying extents in prestressed slab specimens. The response of resistant shear stress to  $a/d$  ratio appears to be reasonably significantly increased for prestressed slab specimens. The universal model for shear proposed in Chapter 8 appears to reflect these parametric trends fairly well. Having the prestressing bars unbonded did not appear to adversely affect resistant shear stress, but adequate end anchorage is essential.

## 5 EVALUATION OF LOCAL BOND

Tests conducted thus far indicated that mechanical anchorage or anchorage bond beyond the point of intersection of the flexural reinforcement and the diagonal shear crack is of fundamental importance in controlling opening of the diagonal shear crack and thus in influencing the shear ultimate limit state. Test results indicate that ultimate shear resistance is impaired if this anchorage of the flexural reinforcement is inadequate, particularly for structural elements unreinforced for shear. Shear reinforcement which crosses the diagonal shear crack is subject to the same criteria, and must also be adequately anchored beyond the point of intersection. The influence of local bond of the flexural reinforcement in particular, however, on the ultimate shear resistance of such structural elements appears to be less well defined. Whereas the traditional local bond check has some relevance in terms of an assessment of the serviceability limit state in flexure in certain structural situations, the direct relevance to the ultimate limit state of shear is not clearly

defined and this is considered to be justification for an investigation as to whether local bond is a meaningful parameter to be included in the formulation of a general model for ultimate shear capacity.

While it is evident from the tests conducted that the presence of flexural reinforcement does influence resistant shear stress of the diagonal shear crack, particularly for elements unreinforced for shear, the manner in which this reinforcement enhances resistant shear stress is relatively inefficient and the mechanics of its operation are complex. It is thus desirable that the influence of local bond on this assessment of the performance of the flexural reinforcement be evaluated.

## 5.1 DESCRIPTION OF THE SPECIMENS

All the specimens tested in this series were simply supported prismatic beams subjected to two point loading. All the beams were of identical section geometry, having overall depth of 250mm and width of 150mm and grade of concrete was not varied intentionally as a parameter under investigation. The flexural reinforcement ratio was varied, however, with consideration being given to a range between 0,5% and 3%. Standard high yield hot-rolled de-

formed bars were used for the flexural reinforcement, with bar diameters of 10mm, 12mm, 16mm and 20mm being considered. No shear reinforcement was included in the specimens. In half the specimens tested, a specific attempt at eliminating local bond capacity of the reinforcement was made, either using gypsum plaster, grease-wrapped paper, or segments of plastic tubing. The bars treated using these techniques are shown in Figure 5.1. For each specimen thus treated, an identical control specimen was cast, with no attempt being made at reducing the bond normally obtained. While the specific local bond reduction for the treated specimens cannot be accurately quantified in terms of this procedure, it is considered that the range of local bond likely to be encountered in practice is more than adequately covered. The range of bar diameters considered is also fairly representative of practical ranges.

## 5.2 DESCRIPTION OF THE TESTS

The beam specimens were all tested in two point loading in a hydraulic testing machine, the shear arm not being varied as a parameter under consideration in these tests. All the specimens were loaded up to failure. Strain and crack-width measurements were taken up to failure, making use of demec targets and gauges

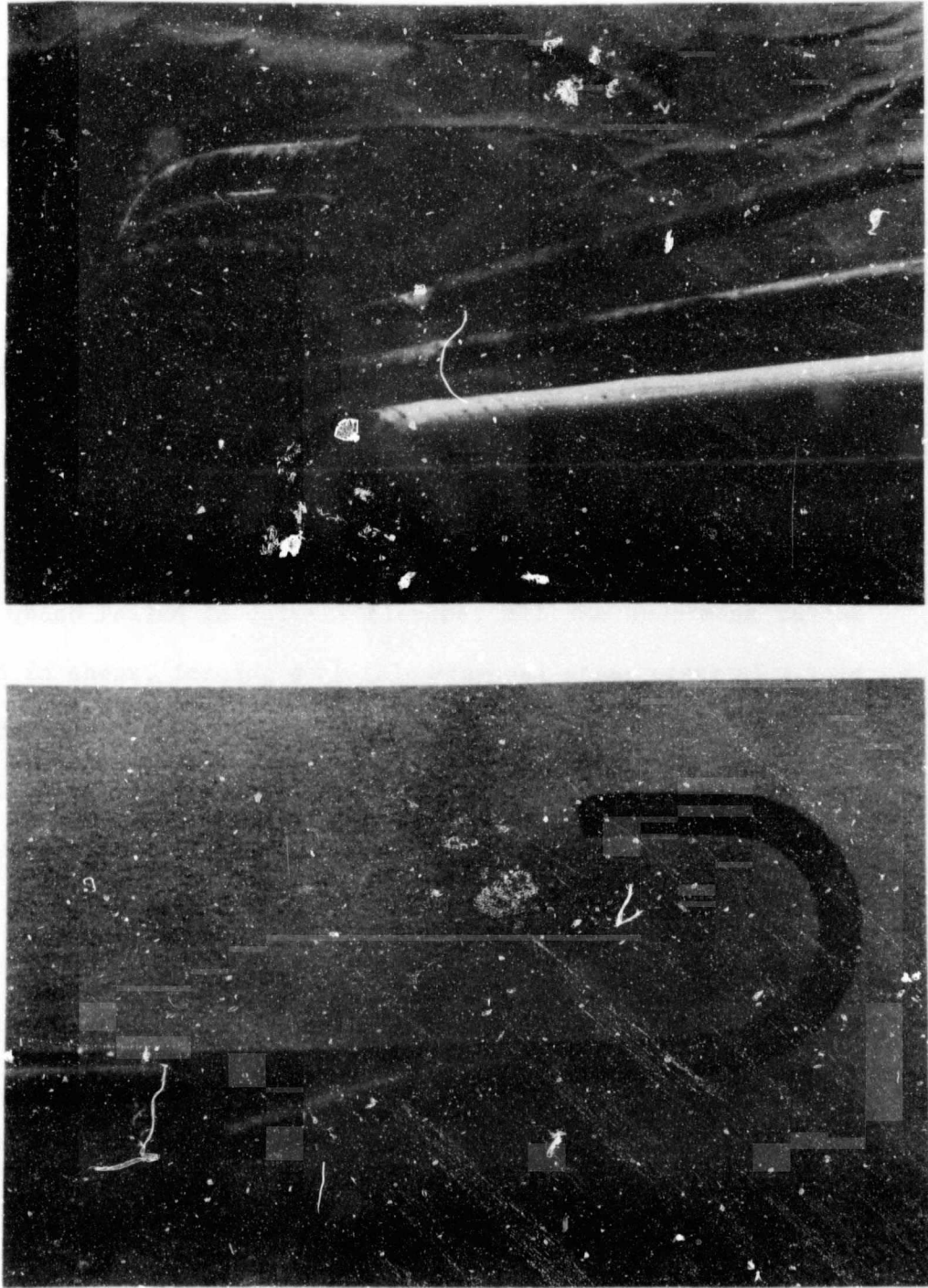

FIGURE 5.1      PHOTOGRAPHS SHOWING TECHNIQUES USED  
FOR THE REDUCTION OF LOCAL BOND ON  
CONVENTIONAL HIGH YIELD REINFORCEMENT.

and load was measured through the hydraulic testing machine. A typical test procedure is indicated in Figure 5.2.

### 5.3 TEST RESULTS

With the exception of one specimen of 0,5% flexural reinforcement, which failed in ductile flexure, all the specimens tested failed in shear, forming a visible diagonal shear crack at a load considerably below that ultimately attained. After the first formation of the diagonal shear crack, widening of this crack was observed, with continued increase in load. The load at which first cracking was visible relative to the ultimate load attained varied considerably, ranging between about 60% and 80%, with larger values being observed for the lightly reinforced specimens. There was no observed difference in this qualitative evaluation for the specimens with or without bond, in that both formed a diagonal shear crack which eventually precipitated the shear failure. The form of the diagonal shear crack is indicated in the photographs in Figure 5.3 for both unbonded and bonded specimens. In recording the ultimate shear force at failure, there was no measurable or consistent trend of the unbonded beams relative to the control specimens, as is evident in the tabulated test results of Appendix C. Both types of specimen failed at

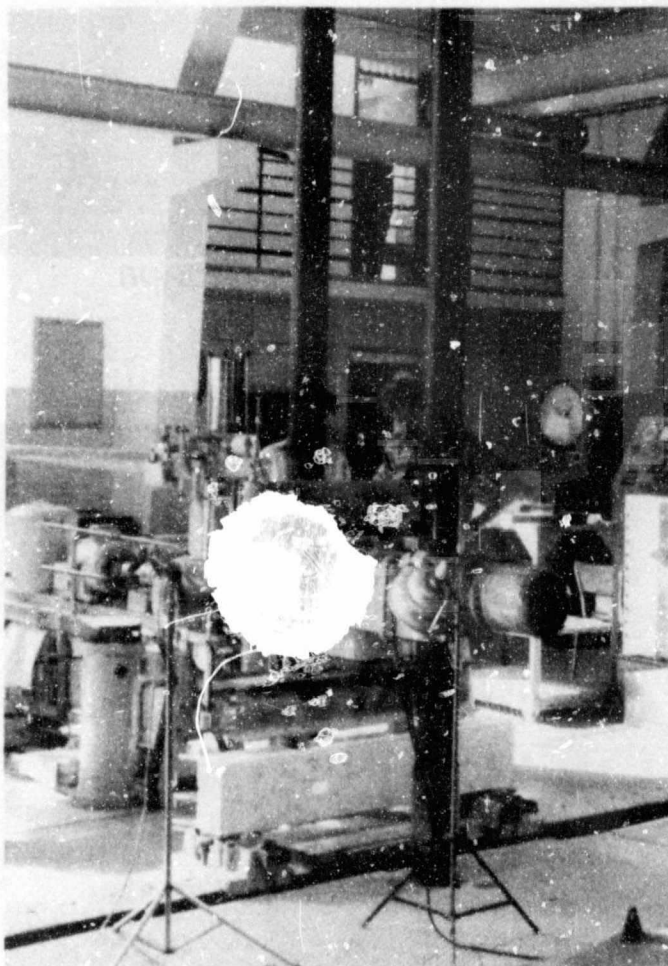
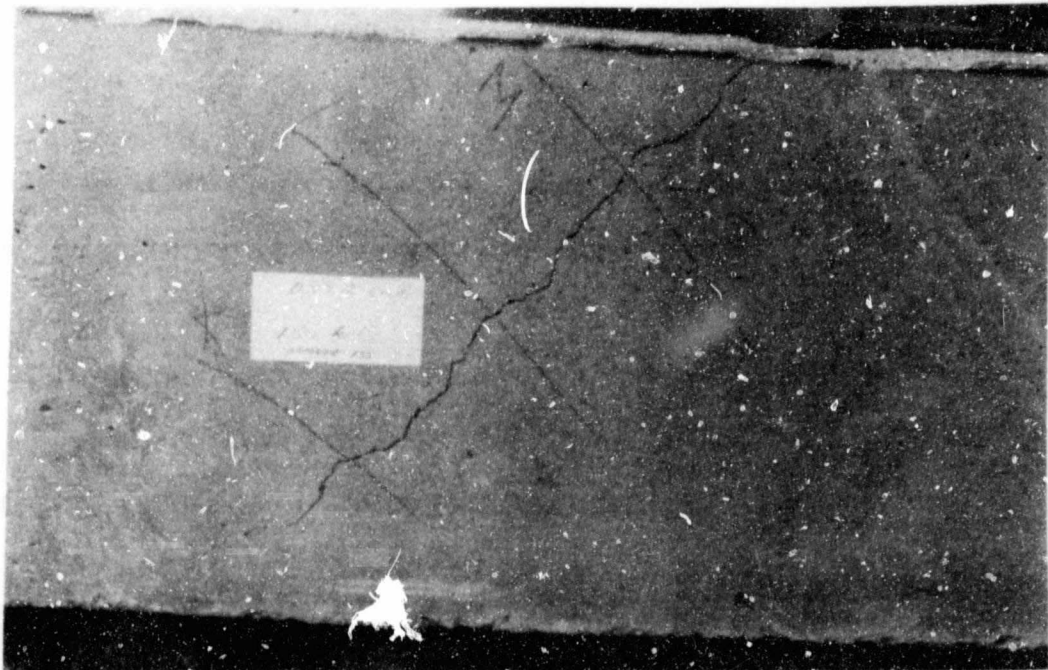
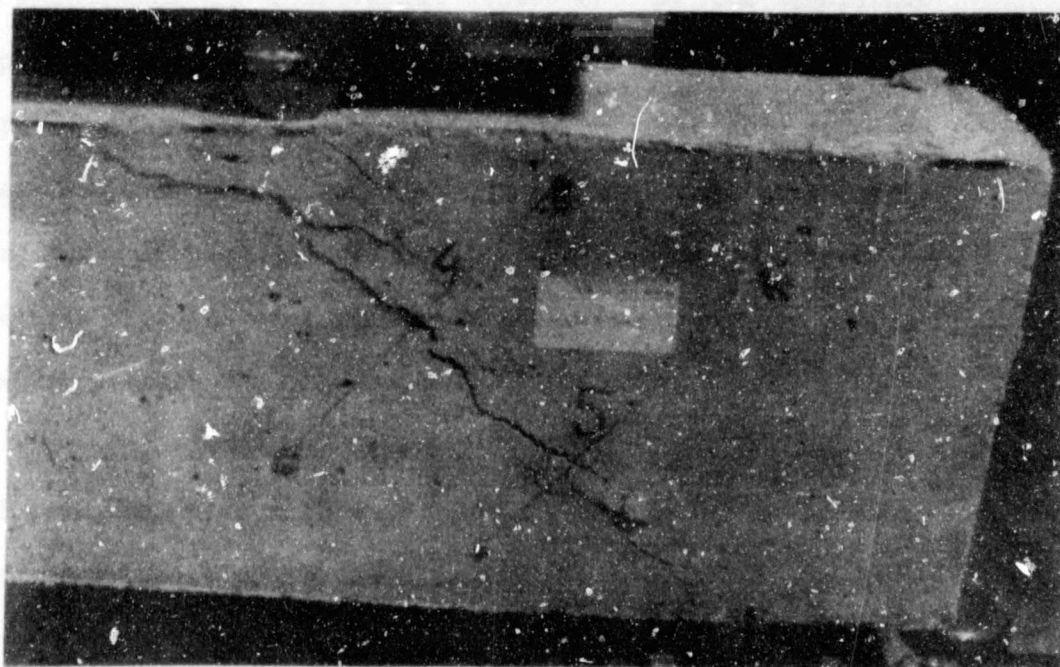

FIGURE 5.2

TWO POINT LOAD TESTS ON BEAM SPECIMENS  
HAVING FLEXURAL REINFORCEMENT WITH  
IMPAIRED LOCAL BOND.



BONDED SPECIMEN



DEBONDED SPECIMEN

FIGURE 5.3      DIAGONAL SHEAR CRACK FORMATION FOR  
BONDED AND DEBONDED BEAM SPECIMENS.

comparable loads with the variations observed being consistent with the variability of the measured concrete strength.

#### 5.4 CONCLUSIONS REGARDING LOCAL BOND

It appears from these test results that local bond, particularly with reference to flexural reinforcement, is not a parameter that warrants inclusion in a universal assessment of the resistant shear performance of the diagonal shear crack which precipitates shear failure. While this is postulated to be reasonable in terms of local bond specifically, the requirement of adequate anchorage or total bond of the flexural reinforcement beyond the point of intersection with the diagonal shear crack is undeniably of fundamental importance.

In evaluating the performance of links, or other types of shear reinforcement, which cross the diagonal shear crack in specimens reinforced for shear, the requirement of end anchorage for each bar crossing the crack remains as important as that for the flexural reinforcement.

While the intent of local bond calculations in codes, of controlling the relationship between the area of flexural re-

inforcement and the bar diameters used, does not appear to influence the performance of the diagonal shear crack specifically, the principles could be relevant to the assessment of the performance of the link reinforcement crossing the diagonal shear crack, in that smaller diameter bars at closer centres appear to be a more desirable form of shear reinforcement than larger diameter bars at larger centres. This phenomenon is related to the spread of the shear reinforcement over the full extent of the diagonal shear crack, in contrast to the relevance of the flexural reinforcement, which is in any event remote from the centre of the diagonal shear and thus relatively inefficient in inhibiting the opening of this shear crack, regardless of its specific local bond characteristics. It is thus the intent of this work to develop a model for shear which will explain this phenomenon and will also be derived on the basis that resistant shear stress is relatively independent of local bond considerations of the flexural reinforcement.

## 6 DEEP BEAMS AND WEBS REINFORCED FOR SHEAR

The tests undertaken in Chapter 4 included a large range of beam specimens. These beams were all unreinforced for shear, with the major emphasis being placed on an evaluation of the influence of the four parameters, depth,  $a/d$  ratio, flexural steel ratio and grade of concrete, on the ultimate resistant shear stress of the beams. The test results for these beams and those of the slabs tested in parallel in Chapter 4 indicated significant parametric trends, in particular the variation of resistant shear stress with depth. In order to establish the trend of shear performance for specimens reinforced for shear, it was considered necessary to test deep beam specimens reinforced for shear in addition to those tested generally. The universal application of the proposed model for shear could thus be evaluated in terms of scale, for elements both unreinforced and reinforced for shear. A further justification for tests on deep beams reinforced for shear is the evaluation of web panels of box- and T-sections. It was also observed in the results of tests on elements unreinforced for

shear and the large increase in resistant shear stress for shallow sections, even in the absence of shear reinforcement, makes evaluation of the performance of shear reinforcement difficult for these types of specimens. The apparent lack of performance of shear reinforcement in thin sections is recognised by various codes of practice, as mentioned in Chapter 4. Taking cognizance of this phenomenon it was felt that a more controlled and clearly defined evaluation of the behaviour of specimens reinforced for shear would thus be obtained in specimens of large scale.

## 6.1 DESCRIPTION OF THE SPECIMENS

With due consideration being given to the above and also to be consistent with the deepest beams tested in the series of beam tests in Chapter 4, the specimen size selected was 1200mm deep. The overall beam specimen dimensions were thus 2700mm in length, 1200mm in depth and 130mm in width. As such, the specimens weighed a little over a ton each, which was the limit which could reasonably be accommodated by the laboratory equipment. All the parameters varied in the tests on similar sized beams in Chapter 4 were kept constant for this series, with the only variable considered here being that of shear reinforcement. All the beams were

thus of 35MPa mean cube strength concrete and all had a flexural steel ratio of 1,5%. The details of the shear reinforcement for these beam specimens are indicated in Figure 6.1. The specimens were reinforced for shear with vertical links, horizontal links and an isotropic mesh of both vertical and horizontal links respectively. The link reinforcement ratio,  $\mu$ , for the former specimens was 0,004, which was intentionally selected as being relatively lightly reinforced for shear. The isotropic mesh link ratio was selected such that an approximately equal total shear reinforcement quantity was present. Mild steel round bars were used for all the link reinforcement, and high yield deformed bars were used for all the flexural reinforcement. The flexural reinforcement, indicated in Figure 6.1, comprised two 32mm, one 25mm and one 20mm diameter high yield bars of average yield stress approximately 450MPa. The shear reinforcement comprised 12mm mild steel round bars placed at 200mm centres for the former specimens, the average yield stress of the mild steel bars being approximately 280MPa. The isotropic mild steel mesh comprised 10mm bars placed both horizontally and vertically.

**Author** Cross Michael Graham

**Name of thesis** A Parametric Evaluation Of The Ultimate Shear Capacity Of Reinforced Concrete Elements. 1985

***PUBLISHER:***

University of the Witwatersrand, Johannesburg

©2013

***LEGAL NOTICES:***

**Copyright Notice:** All materials on the University of the Witwatersrand, Johannesburg Library website are protected by South African copyright law and may not be distributed, transmitted, displayed, or otherwise published in any format, without the prior written permission of the copyright owner.

**Disclaimer and Terms of Use:** Provided that you maintain all copyright and other notices contained therein, you may download material (one machine readable copy and one print copy per page) for your personal and/or educational non-commercial use only.

The University of the Witwatersrand, Johannesburg, is not responsible for any errors or omissions and excludes any and all liability for any errors in or omissions from the information on the Library website.