

- 4) Valuable information on the condition of an existing shaft after analysis of the measurements taken there.

No known attempt in South Africa had been made to measure wheel loads continuously before this project and it was important that due consideration was given to the choice of measuring equipment in order to obtain usable results, especially as it was impracticable if not impossible to repeat any of the test measurements.

## 2.2 Measurements and data storage

All the measurements were taken in shafts under normal operating conditions. The background investigation into the methods of taking and recording measurement information was carried out by Krige<sup>3</sup> who decided on appropriate methods, consistent with the practical constraints and required accuracy.

Continuous measurements of lateral accelerations and wheel loads during conveyance operation were taken. For this purpose load cells were placed in the guide-roller assemblies to measure wheel loads and accelerometers were mounted on the conveyance at desired locations. The load cells and accelerometers were connected to a fourteen channel tape recorder via suitable amplifiers.

The tape recorder and amplifier with their power supply, consisting of a set of 12 V DC batteries were placed in a rigid, waterproof and relatively shockproof steel box fixed to the conveyance at a suitable location so as not to interfere with its normal operation. Thus it was possible to obtain continuous measurements of the wheel loads and lateral accelerations.

AN EXPERIMENTAL STUDY OF THE DYNAMIC  
LOADING ON MINESHAFT STEELWORK WITH  
PARTICULAR REFERENCE TO FATIGUE LOADING

MIHAIL FOTOPOULOS

A Dissertation submitted to the Faculty of Engineering,  
University of the Witwatersrand, Johannesburg for the  
Degree of Master of Science in Engineering.

JOHANNESBURG, August 1983.

DECLARATION

I, Mihail Fotopoulos, declare that this dissertation is my own, unaided work. It is being submitted for the degree of Master of Science in Engineering in the University of the Witwatersrand, Johannesburg. It has not been submitted before for any degree or examination in any other University.

M Fotopoulos

ACKNOWLEDGEMENTS

I wish to express my sincere appreciation to the following persons:

To Prof. A R Kemp for the valuable advice and assistance he has given throughout this work.

To Geoff Krige for the practical and analytical assistance he has given.

To Jean McClean for competently typing this dissertation.

SYNOPSIS

This dissertation describes the site measurement of the dynamic loads on the wheels of mineshaft conveyances and analysis of these loads from a fatigue point of view. The measurement procedure, details of the load cells used, calibration details and the recording of data is described. Fatigue analysis includes a discussion of the various cycle-counting methods and their merits, a comparison of the various methods and the development of a computer programme for cycle-counting. The accuracy of the computer programme is discussed and comparisons with the cycle-counting methods are made. The experimental measurements are analysed using the computer programme and the effect of different variables on fatigue loading is discussed. An empirical formula which includes the effect of some variables is proposed for the design of mineshaft steelwork components against fatigue.

```

WRITE(6,114) (HEAD(I), I=1,4)
116 FORMAT(//,T30,80A1,//,T35,'FAILURE LIST CONSIDERED',
@ //,T35, 21('='),//)
WRITE(6,101)
101 FORMAT(T10,'LOAD RANGE (KN)',T42,'NO. OF CYCLES',
@ T42,13('*'),//)
IF(MX.EQ.3) GO TO 42
IF(MX.EQ.2) GO TO 43
IF(MX.EQ.1) GO TO 44
41 WRITE(6,105)
105 FORMAT(T30,'WHEEL 1',T40,'WHEEL 2',T50,'WHEEL 3',T60,'WHEEL 4',
@ //,T30,7('*'),T40,7('*'),T50,7('*'),T60,7('*'),//)
DO 51 J=1,JX
AJ=J
51 WRITE(6,106) AJ, (NC1(J,K), K=1,4)
106 FORMAT(T12,F5.1,T32,I5,T42,I5,T52,I5,T62,I5)
WRITE(6,107) (AVL(I), I=1,4)
107 FORMAT(//,T10,'MEAN LOAD (KN) =',T31,F6.2,T41,F6.2,T51,F6.2,
@ T61,F6.2)
GO TO 61
42 WRITE(6,108)
108 FORMAT(T35,'WHEEL 1',T45,'WHEEL 2',T55,'WHEEL 3',//,T35,7('*'),
@ T45,7('*'),T55,7('*'),//)
DO 52 J=1,JX
AJ=J
52 WRITE(6,109) AJ, (NC1(J,K), K=1,3)
109 FORMAT(T12,F5.1,T37,I5,T47,I5,T57,I5)
WRITE(6,110) (AVL(I), I=1,3)
110 FORMAT(//,T10,'MEAN LOAD (KN) =',T36,F6.2,T46,F6.2,T56,F6.2)
GO TO 61
43 WRITE(6,111)
111 FORMAT(T37,'WHEEL 1',T52,'WHEEL 2',//,T37,7('*'),T52,7('*'),//)
DO 53 J=1,JX
AJ=J
53 WRITE(6,112) AJ, (NC1(J,K), K=1,2)
112 FORMAT(T12,F5.1,T38,I5,T53,I5)
WRITE(6,113) (AVL(I), I=1,2)
113 FORMAT(//,T10,'MEAN LOAD (KN) =',T37,F6.2,T52,F6.2)
GO TO 61
44 DO 54 J=1,JX
AJ=J
54 WRITE(6,114) AJ, NC1(J,1)
114 FORMAT(T12,F5.1,T45,I5)
WRITE(6,115) AVL(1)
115 FORMAT(//,T10,'MEAN LOAD (KN) =',F6.2)
61 WRITE(6,104) DIST
104 FORMAT(//,T10,'LENGTH OF SHAFT CONSIDERED =',F7.1,2X,'M')
CLOSE(UNIT=1)
STOP
1000 I)RMAT(3X,F12.4,F12.4,I6)
1200 FORMAT(I7)
END

```

```

WRITE(6,116) (HEAD(I), I=1,80)
116  FORMAT(//,T30,80A1,//,T35,'FATIGUE LOAD SPECTRUM',
      /,T35, 21('*'),//)
      WRITE(6,101)
101  FORMAT(T10,'LOAD RANGE (KN)',T42,'NO. OF CYCLES',//,T10,15('*'),
      T42,13('*'),//)
      IF(MX.EQ.3) GO TO 42
      IF(MX.EQ.2) GO TO 43
      IF(MX.EQ.1) GO TO 44
41   WRITE(6,105)
105  FORMAT(T30,'WHEEL 1',T40,'WHEEL 2',T50,'WHEEL 3',T60,'WHEEL 4'
      /,T30,2X('*'),T40,7('*'),T50,7('*'),T60,7('*'),/)
      DO 51 J=1,JX
      AJ=J
51   WRITE(6,106) AJ, (NC1(J,K), K=1,4)
106  FORMAT(T12,F5.1,T32,I5,T42,I5,T52,I5,T62,I5)
      WRITE(6,107) (AVL(I), I=1,4)
107  FORMAT(//,T10,'MEAN LOAD (KN) =',T31,F6.2,T41,F6.2,T51,F6.2,
      T61,F6.2)
      GO TO 51
42   WRITE(6,108)
108  FORMAT(T35,'WHEEL 1',T45,'WHEEL 2',T55,'WHEEL 3',//,T35,7('*'),
      T45,7('*'),T55,7('*'),/)
      DO 52 J=1,JX
      AJ=J
52   WRITE(6,109) AJ, (NC1(J,K), K=1,3)
109  FORMAT(T12,F5.1,T37,I5,T47,I5,T57,I5)
      WRITE(6,110) (AVL(I), I=1,3)
110  FORMAT(//,T10,'MEAN LOAD (KN) =',T36,F6.2,T46,F6.2,T56,F6.2)
      GO TO 52
43   WRITE(6,111)
111  FORMAT(T37,'WHEEL 1',T52,'WHEEL 2',//,T37,7('*'),T52,7('*'),/)
      DO 53 J=1,JX
      AJ=J
53   WRITE(6,112) AJ, (NC1(J,K), K=1,2)
112  FORMAT(T12,F5.1,T38,I5,T53,I5)
      WRITE(6,113) (AVL(I), I=1,2)
113  FORMAT(//,T10,'MEAN LOAD (KN) =',T37,F6.2,T52,F6.2)
      GO TO 53
44   DO 54 J=1,JX
      AJ=J
54   WRITE(6,114) AJ, NC1(J,1)
114  FORMAT(T12,F5.1,T45,I5)
      WRITE(6,115) AVL(1)
115  FORMAT(//,T10,'MEAN LOAD (KN) =',F6.2)
61   WRITE(6,104) DIST
104  FORMAT(//,T10,'LENGTH OF SHAFT CONSIDERED =',F7.1,2X,'M')
      CLOSE(UNIT=1)
      STOP
1000 FORMAT(3X,F12.4,F12.4,I6)
1200 FORMAT(I7)
      END

```





LIST OF FIGURES

	<u>PAGE</u>
1.1 Plan of research ... ..	5
1.2 Simplified computer model ... ..	6
1.3 Schematic layout of measurements ... .. on conveyances	7
2.1 Conveyance arrangement in shaft ... ..	13
2.2 'Patent Products' Guide-roller assembly	14
2.3 'Patent Products' Guide-roller assembly	15
2.4 'Patent Products' Guide-roller assembly	16
2.5 Plan of 'SKF' type guide-roller ... .. assembly	17
2.6 Front elevation of 'SKF' type ... .. guide-roller assembly	18
2.7 Side elevation of 'SKF' type ... .. guide-roller assembly	19
2.8 Adjusting screw type load cell ... ..	21
2.9 Socket type load cell ... ..	23
2.10 Load cell for 'SKF' guide wheels ... ..	24
2.11 Calibration relationships Load cell No. 1	26
2.12 Calibration relationships Load cell No. 2	26
2.13 Calibration relationships Load cell No. 3	27
2.14 Calibration relationships Load cell No. 4	27
2.15 Calibration plate ... ..	29
2.16 Dynamic calibration at frequency ... .. of 0,7 hz and amplitude of 9 kN	31
2.17 Dynamic calibration at frequency ... .. of 1,85 hz and amplitude of 4 kN	31
2.18 Wheel load record ... .. President Steyn Number 4 shaft 10t Skip hoisting at 15 m/s	34
3.1 Load records which test efficiency ... .. of a computer programme	39
3.2 Example of Range-Pair cycle ... .. counting method	43
3.3 Example of Rainflow cycle counting ... .. method	44

## LIST OF FIGURES continued ....

	<u>PAGE</u>
3.4 Example of reservoir method of ... .. cycle counting	47
3.5 Record used for comparing the various... counting methods	48
3.6 Typical load record predicted ... .. by the theoretical DISCS model	53
3.7 Load record from the experimental ... .. measurements	53
3.8 Part of the load record ... ..	56
3.9 Load record ideally suited for ... .. analysis by the computer programme	57
3.10 Load record which highlights ... .. weakness in programme	58
3.11 Record used for comparing computer ... .. programme results to the cycle- counting methods	59
3.12 Record for which unfavourable .. ... results are obtained when using computer programme	60
3.13 Flow chart for FAG ... ..	61
3.14 Typical output from FAG ... ..	62
4.1 Typical S-N curve ... ..	65

LIST OF TABLES

	<u>PAGE</u>
... ..	41
... ..	49
... ..	60
... ..	68
4.2 Fatigue load spectra obtained from experimental records of wheel load expressed in the form of the equivalent number of applications of a 5kN load range ... ..	69
4.3 Deelkraal No. 1 Shaft skip Some statistical properties of the fatigue loading (in terms of number of applications of a 5kN range) from 12 consecutive sections of record each 5 sec long ... ..	77
4.4 Deelkraal No. 1 shaft skip Some statistical properties of the fatigue loading (in terms of number of applications of a 5kN range) from 6 consecutive sections of record each 10 sec long. ... ..	78
4.5 Calculation of 5% exceedence limit ... ..	79
4.6 Analysis of 15 m/s test runs ... ..	81
4.7 Analysis of 10 m/s and 5 m/s test runs ... ..	82
4.8 Hartebeesfontein 6# Cage Fatigue loading comparisons ... ..	85
4.9 Comparison between DISCS and experimentally obtained fatigue loading spectra Hartebeesfontein 6 # 105 men cage. ... ..	88

When the 'Baker' products' wheel this screw was in compression whereas with the 'SKF' wheel it was in tension.

Some shafts and above assemblies were modified in detail by the mines and this was done for better performance of the guide wheels or to clear other equipment in the shaft.

#### 4.6 Load cells

The load cells used for measurement of the wheel loads had to be specially made up in the laboratory to suit different guide-roller assemblies in various mineshafts. In designing these load cells durability and ease of installation and removal as mentioned previously had to be taken into account. Because of the different guide-roller assemblies and arrangements in the different mineshafts three different types of load cell had to be made up.

Unfortunately even with three different types of load cell it was found impossible to cater for all mineshafts. The underlying reason for this was that because of time limitations in the mineshafts it was not possible to solve last minute difficulties which were not anticipated well in advance. In addition because of the travelling and interruption to shaft production schedules involved it was impossible for the test to be repeated.

The main difficulty lay with the installation of the load cells. In some cases the load cells could not be fitted because of their size while in others if they were fitted they hindered normal operation of the conveyance and as a result had to be removed.

## CHAPTER 1 : GENERAL INTRODUCTION

### 1.1 Introduction

In recent years demands for increased production and reduced costs in the mining industry have resulted in major changes in the layout and design of modern mineshafts. These changes include:

- (a) Increased depth of mineshaft in order to exploit less accessible ore deposits.
- (b) Larger capacity mineshafts operating at higher hoisting speeds in order to increase productivity.
- (c) The introduction of new lightweight materials for construction of conveyances.
- (d) Larger capacity conveyances.
- (e) Attempts to increase the bunton spacing in the shaft in order to reduce installation and maintenance costs and reduce shaft construction and equipping time.
- (f) Streamlining bunton profiles to reduce ventilation resistance.

While all these changes have been introduced the design of the mineshaft steelwork has not changed much over the years and is still based on empirical methods which do not take into account the dynamic behaviour of the system. As a result an increasing number of shafts are

experiencing problems related to dynamic behaviour such as high levels of vibration and fatigue damage<sup>40</sup>. These problems accelerate overall deterioration of the shaft steelwork, necessitating costly maintenance at more frequent intervals and result in production losses of the shaft.

Some suggested solutions to particular problems have been proposed by mineshafts which in the past experienced problems related to dynamic behaviour<sup>41</sup>. These include replacing loosening bolts by bolts with locking nuts, rewelding fatigue cracks, replacing cracked parts by new, heavier parts and limiting unacceptable vibration levels by reducing hoisting speeds. These are all short term solutions to the effects of the underlying problem of dynamic loads, and in any case can only be implemented after the problem area is identified sometimes with adverse effects on shaft production.

It is obvious that a long term solution to the problem of dynamic behaviour in mineshafts is required in order to prevent the problems arising and as a result extensive research has been initiated to study the dynamic response of shaft steelwork and conveyances.

## 1.2 Literature survey

Work published covering research in this field includes the following<sup>42</sup>.

- a) Several small studies by individual mines as well as investigations into specific areas, such as guide irregularities and rigidity, and the stress distribution in buntons.

- b) A shaft steelwork design code was published by the CSIR<sup>d</sup> but its recommendations have not found much acceptance in practice. It was based on a simplified mathematical model which represented a conveyance as a three dimensional single rigid body symmetrical about all three axes with movement in each direction being treated separately. This simplified model facilitated assessment of the interaction of the major variables and areas of possible instability.
  
- c) The most comprehensive work to date, which led to the publication of a German Standard on design loads for hoists and hoist components, was carried out at Tremonia, Germany. The work included a full programme of tests in a shaft, investigations to determine damping coefficients, tests on various types of guide wheels, as well as the development of mathematical models to determine natural frequencies, stability characteristics and the dynamic loading on a conveyance.
  
- d) The United States Bureau of mines has commissioned work which has been carried out at the Colorado School of Mines<sup>e</sup>. A computer model, SKIP II, has been set up to model conveyance behaviour in three dimensions. The conveyance is considered as a single body with the guides being simply supported between rigid buntons. These two assumptions do not represent the real behaviour of the conveyance adequately.

### 1.3 Present Research Project

The object of the present research project was to investigate the dynamic behaviour of conveyances in steel-equipped shafts. The project was led by

- b) A shaft steelwork design code was published by the CSIR<sup>9</sup> but its recommendations have not found much acceptance in practice. It was based on a simplified mathematical model which represented a conveyance as a three dimensional single rigid body symmetrical about all three axes with movement in each direction being treated separately. This simplified model facilitated assessment of the interaction of the major variables and areas of possible instability.
  
- c) The most comprehensive work to date, which led to the publication of a German Standard on design loads for hoists and hoist components, was carried out at Tremonia, Germany<sup>7</sup>. The work included a full programme of tests in a shaft, investigations to determine damping coefficients, tests on various types of guide wheels, as well as the development of mathematical models to determine natural frequencies, stability characteristics and the dynamic loading on a conveyance.
  
- d) The United States Bureau of mines has commissioned work which has been carried out at the Colorado School of Mines<sup>1</sup>. A computer model, SKIP II, has been set up to model conveyance behaviour in three dimensions. The conveyance is considered as a single body with the guides being simply supported between rigid buntons. These two assumptions do not represent the real behaviour of the conveyance adequately.

### 1.3 Present Research Project

The object of the present research project was to investigate the dynamic behaviour of conveyances in steel-equipped shafts. The project was led by

Mr. G Krige, a PhD student, and the project team consisted of himself and two MSc students, Mr. B Alport and Mr. M Fotopoulos who later joined the project team. The whole project was initiated by Professor A R Kemp and was carried out under his supervision.

The plan of research that was adopted is shown in Figure 1.1.

A major part of the work was carried out by Krige<sup>3</sup>, who amongst other things, was responsible for interviewing the relevant people in the mining industry, developing the theoretical computer model of the conveyance, investigating suitable methods of conducting the experimental measurements and purchasing and setting up the equipment required for the experimental measurements and analysis.

1.4 Theoretical model of shaft conveyance

The theoretical model DISCS (Dynamic Interaction of Shaft Conveyance Systems) that was set up by Krige<sup>3</sup> is shown in Figure 1.2.

The main features of this model are the following:

- a) Dynamic behaviour: in one plane only (the plane of the guides) is considered.
- b) The conveyance is modelled as three rigid bodies corresponding to the top transom, the body of the conveyance and the bottom transom.
- c) Only four degrees of freedom are considered, these being horizontal translation of each rigid body and rotation of each mass about its centre of gravity, which is the same for all three masses as the bridle was considered to be inextensible.

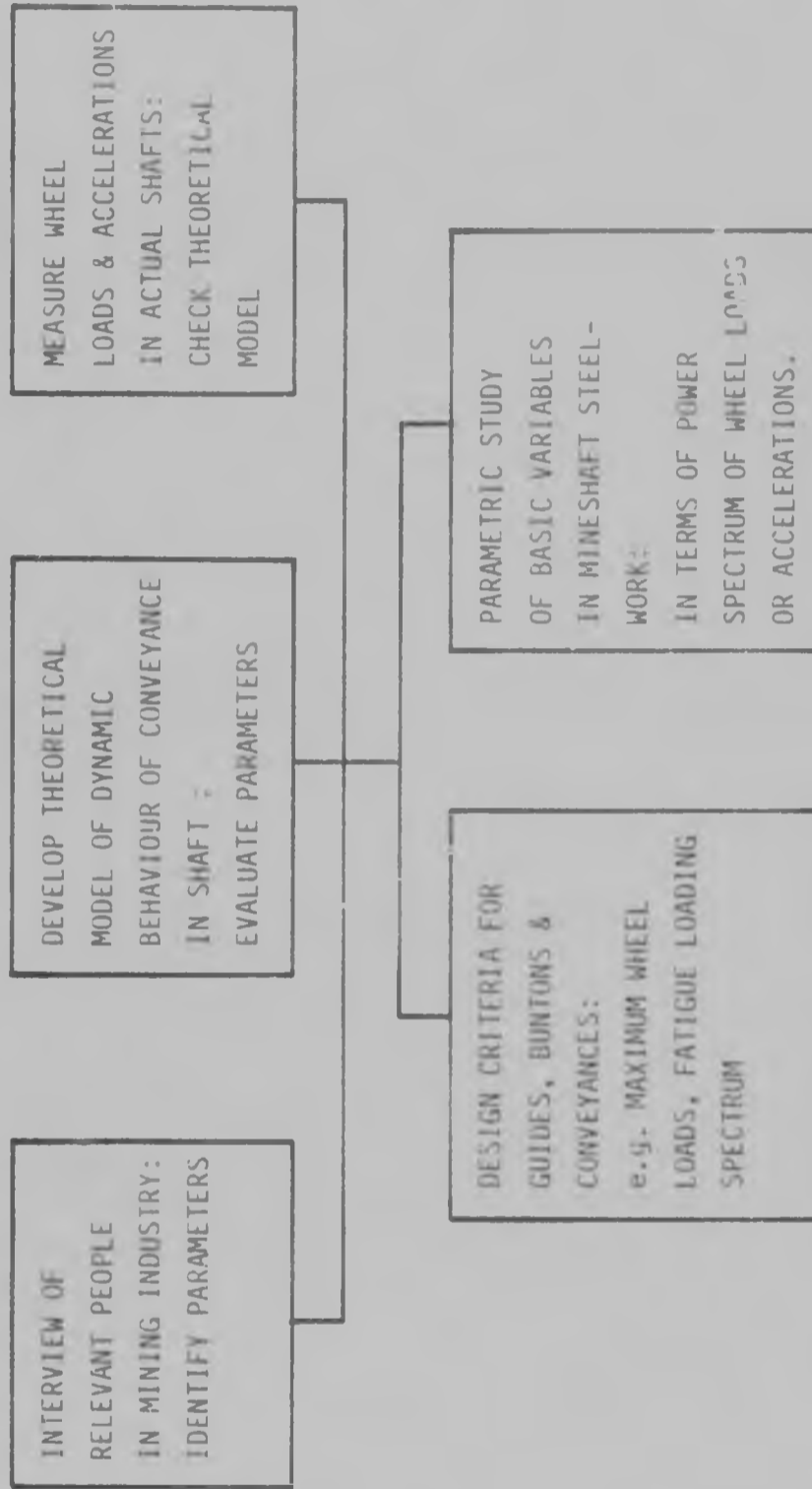

FIGURE 1.1 : PLAN OF RESEARCH

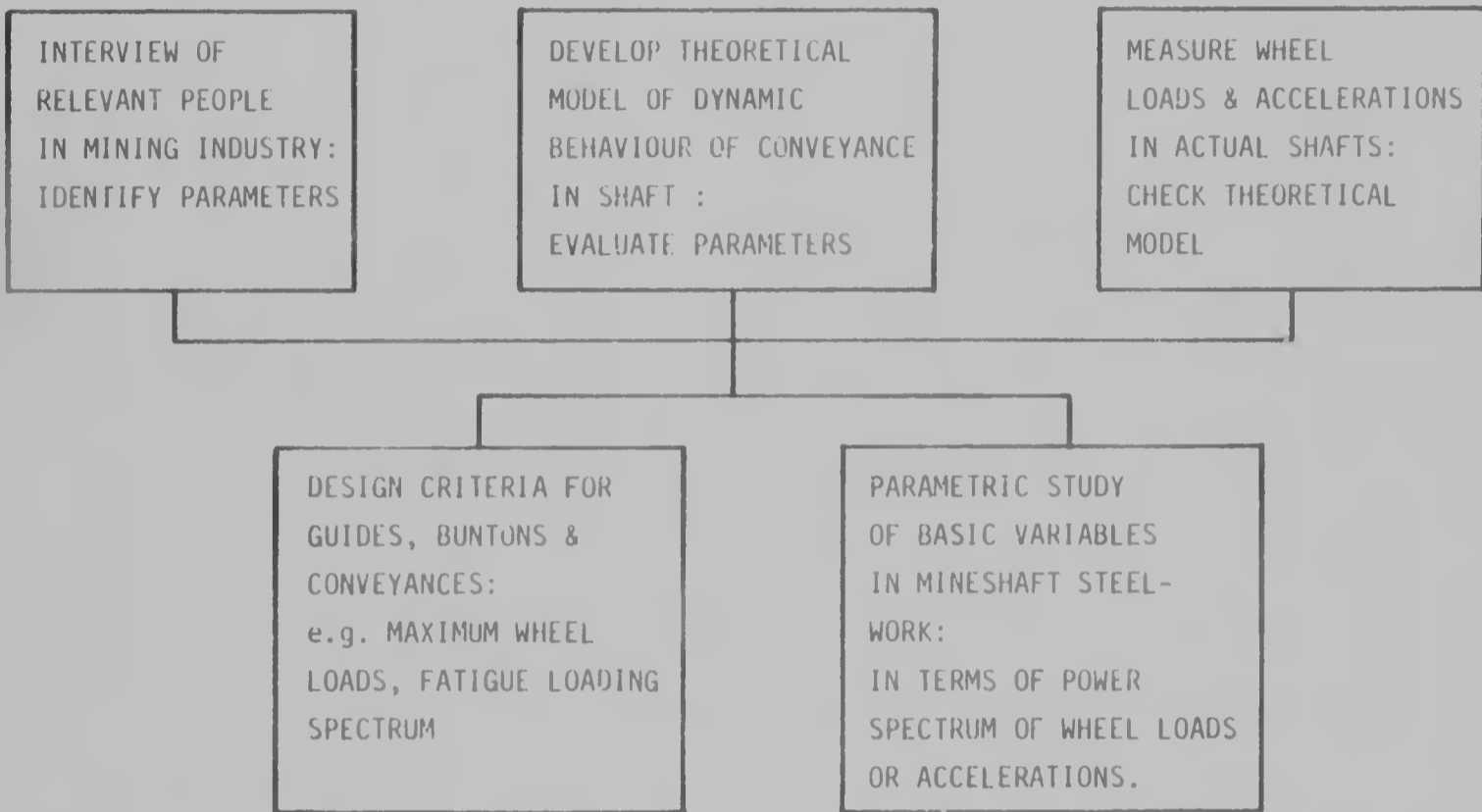
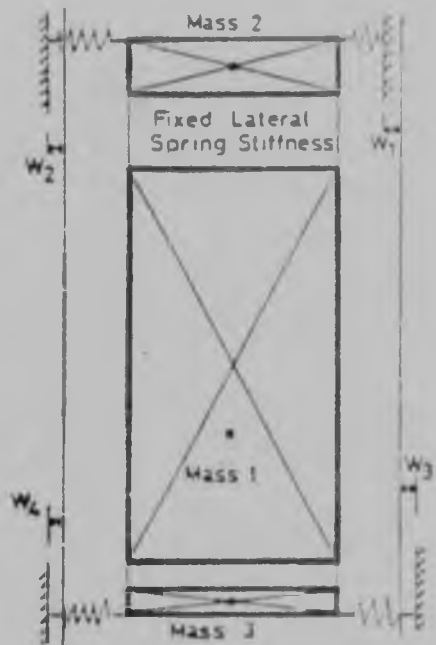

FIGURE 1.1 : PLAN OF RESEARCH



Each mass can move laterally independently and rotate.

The values  $W$  are set by guide position, preload, etc.

FIGURE 1.2 : SIMPLIFIED COMPUTER MODEL

- d) The hoisting cable and all vertical motion and weight are ignored.
- e) Dynamic excitation of the shaft steelwork is ignored but the altering flexibility of the guide is allowed for in conjunction with the guide-wheel flexibility.
- f) Guide misalignment and mismatch is included in the model.

### 1.5 Experimental measurements

These measurements were essential to verify the predictions of the theoretical model. In order to describe dynamic behaviour, measurements of the wheel loads and accelerations of the three rigid bodies were required. The experimental programme was conducted by Krige and Fotopoulos and the measurements taken are shown schematically in Figure 1.3 and described in more detail in Chapter 2.

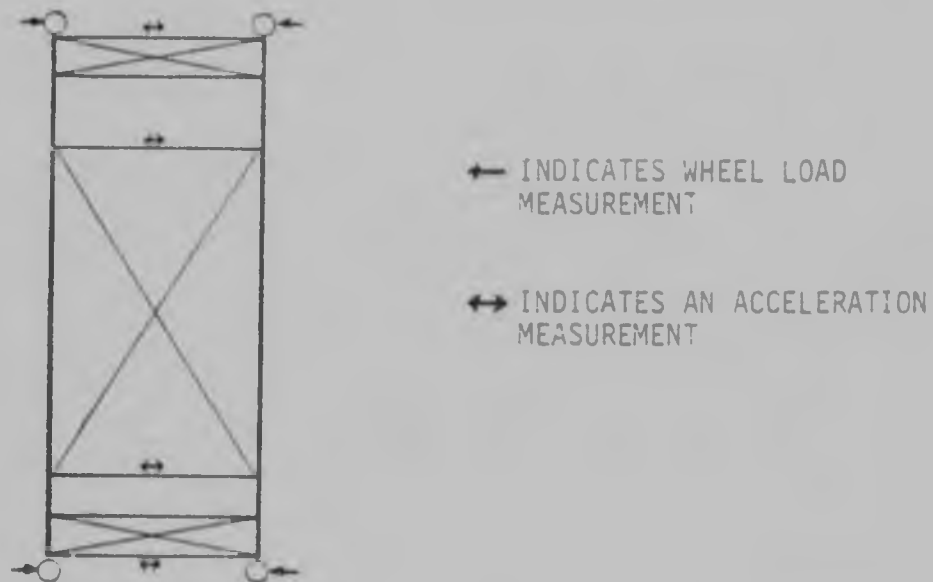

FIGURE 1.3 : SCHEMATIC LAYOUT OF MEASUREMENTS ON CONVEYANCES

### 1.6 Writer's involvement in the research project

This involvement covered the following aspects of the project:

- a) Testing and calibration of the load cells used for measuring the wheel loads, both in the laboratory and on site.
- b) Assisting in the experimental measurements in the various mineshafts.

- c) Development of procedures for the analysis of the wheel loads from a fatigue point of view and application of these procedures to measurements in shafts.

This dissertation covers the following aspects of the project:

- a) The measurement of the wheel loads in the shafts.
- b) The fatigue loading on mineshaft structural components.

## CHAPTER 2 : SITE MEASUREMENT OF WHEEL LOADS

### 2.1 Introduction

From the outset of this research project it was accepted that the experimental measurements on site would form, perhaps, the greater part of the project. Having decided this, it was obvious that the measurement programme would have to be quite extensive and include as far as possible all the variables affecting the dynamic behaviour of mineshaft steelwork. Continuous records of the contact loads between the wheels of the guide-roller assemblies and the guides were essential if dynamic behaviour was to be described. In addition to giving an indication of the applicability of the theoretical computer model DISCS in predicting dynamic behaviour, these records could also be used to yield valuable information on the following aspects of mine-shaft behaviour:

- 1) An indication of the validity of the empirical design rules presently used for the design of mineshaft steelwork.
- 2) Information on the effect of different variables viz. conveyance mass, hoisting speed, bunton spacing, etc., on the overall behaviour of mine-shaft steelwork.
- 3) Information regarding the fatigue loading spectrum on the conveyance and various other components in the mineshaft.

There was practically no difference in behaviour between the new and the old wheels.

The same calibration constant applies to all four load cells.

In addition it was found after obtaining the relationship between the load in the cell and the voltage output from the strain gauges, in a direct compression test on the cells alone, that the force on the adjusting screw can be obtained from the wheel load by considering equilibrium conditions and neglecting friction in the bearing.

From these findings it was reasonable to assume a linear relationship between wheel load and output voltage especially as this simplified calibration of the varying load considerably.

The best straight line plot representing this relationship is one with a slope of  $0,026\text{V/kN}$ . All calibration test readings lie within 1,5 standard deviations away from this line (giving a confidence limit of over 95%). The coefficient of variation at all load levels is less than 1%.

For the eye bolt type tension load cells (Figure 2.10) the relationship between load and voltage output was  $0,021\text{V/kN}$  and for the socket type load cells  $0,022\text{V/kN}$ .

#### Site calibration of load cells

This was a static calibration conducted on site. It was carried out as a check calibration in order to verify mainly that local conditions in a mineshaft do not influence wheel load measurement and that

After completion of the measurements at each mineshaft analysis was carried out. The tape containing the recorded information was replayed in the tape recorder this time connected to an Analogue-Digital converter and a PDP 11/23 computer at the University. The signals were sampled and, after calibration, data files were created containing the relevant information, ready for analysis.

### 2.3 Measurement of the wheel loads

Measurement of the wheel loads formed an important part of the experimental programme and was achieved by introducing load cells at convenient locations in the guide-roller assemblies, and connecting these load cells to the tape recorder. As the measurements were conducted in busy production shafts there were some practical considerations placed on the measurement programme as a whole and on the load cells in particular.

The first constraint related to the time required to attach and remove the instrumentation from the conveyance after testing. This time had to be kept to a minimum as the time available for the whole test was severely limited because of production considerations by the respective mines. This meant that the load cells had to have the feature of easy installation and subsequent removal.

The second consideration related to the durability of the instrumentation as it had to operate reliably under severe vibrational and environmental conditions in the shaft. It is clear that in addition to the instrumentation being robust, attachment would have to be simple so that the instrumentation did not come loose during normal operation.

Other considerations related to the fact that the shafts where testing was done were far from the University. This necessitated thorough research into the conveyance arrangement beforehand as it was imperative that each test was successfully conducted without repetition. In addition because the life of the batteries forming the power supply was only about three hours, testing time had to be limited to about one and one half hours, allowing for installation, site calibration and other time consuming factors.

#### 2.4 Conveyance arrangement in the shaft

A brief description of the conveyance arrangement in the shaft is included here in order to place the following discussion into perspective. This arrangement is shown schematically in Figure 2.1.

The guide-roller assemblies are used to maintain the alignment of the conveyance during operation. Each guide-roller assembly consists of three rubber lined guide wheels which are so located as to limit movement of the conveyance in the horizontal plane at the wheel location. There are four guide roller assemblies in each conveyance, located as shown in Figure 2.1. The guides run the whole length of the shaft and are supported at regular intervals by transverse supports known as buntons which are in turn supported on the shaft walls.

The whole arrangement is obviously three-dimensional, but in this project the simplifying assumption was made that vibrations in the plane of the guides were of greater significance and out-of-plane vibrations were ignored, although they were monitored in some mineshafts during the tests for verification of the original assumptions and later comparisons.

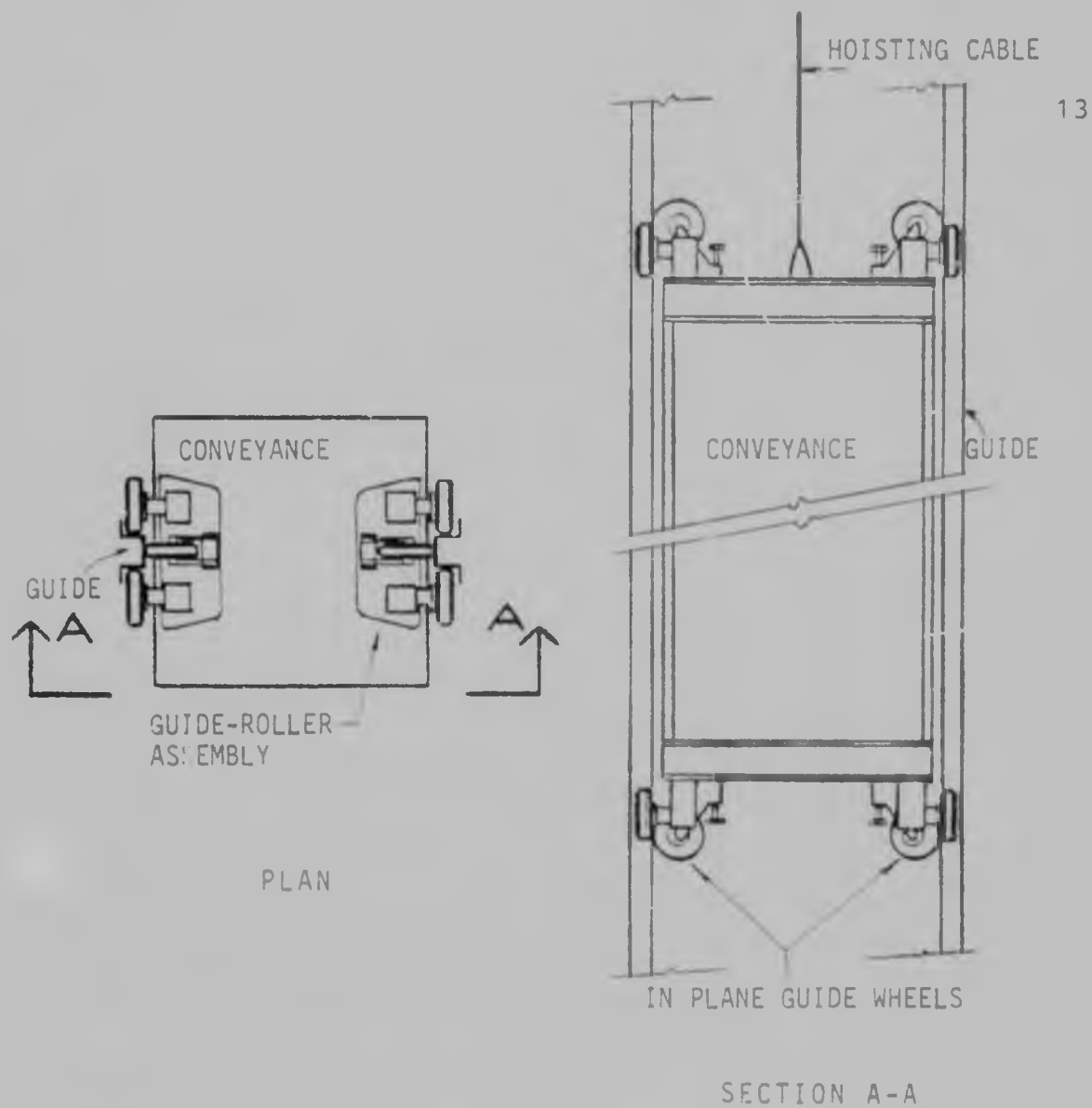

FIGURE 2.1 : CONVEYANCE ARRANGEMENT IN SHAFT

### 2.5 Guide-roller assemblies

The guide-roller assemblies used in shafts where measurements were taken were generally of two types. The one type was the 'Patent Products' guide frame assembly, details of which are shown in Figures 2.2 to 2.4.

The other type was the 'SKF' guide roller assembly, details of which are shown in Figures 2.5 to 2.7.

The basic difference between the two types was the location of the buffer and the adjusting screw. In

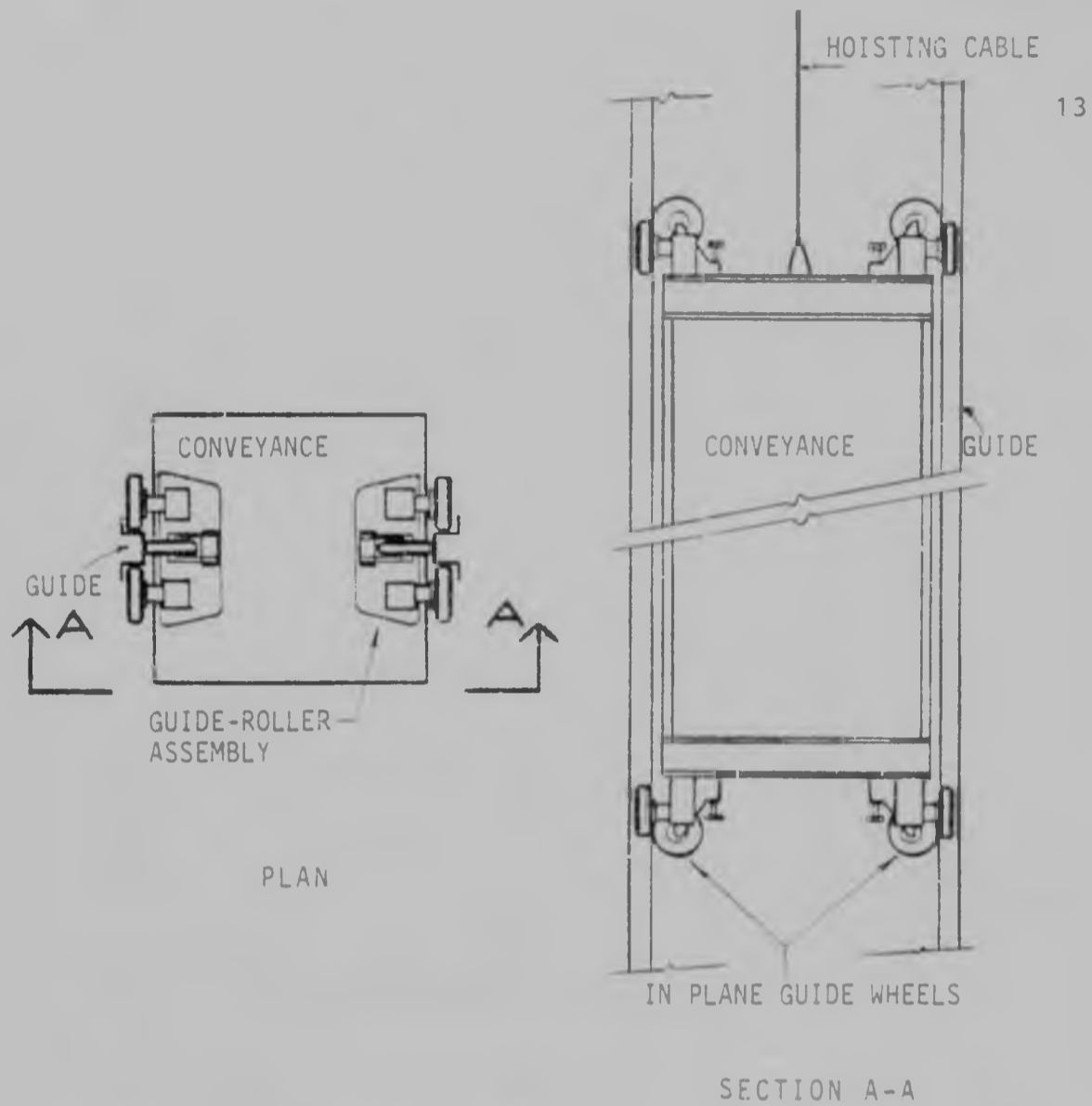

FIGURE 2.1 : CONVEYANCE ARRANGEMENT IN SHAFT

### 2.5 Guide-roller assemblies

The guide-roller assemblies used in shafts where measurements were taken were generally of two types. The one type was the 'Patent Products' guide frame assembly, details of which are shown in Figures 2.2 to 2.4.

The other type was the 'SKF' guide roller assembly, details of which are shown in Figures 2.5 to 2.7.

The basic difference between the two types was the location of the buffer and the adjusting screw. In

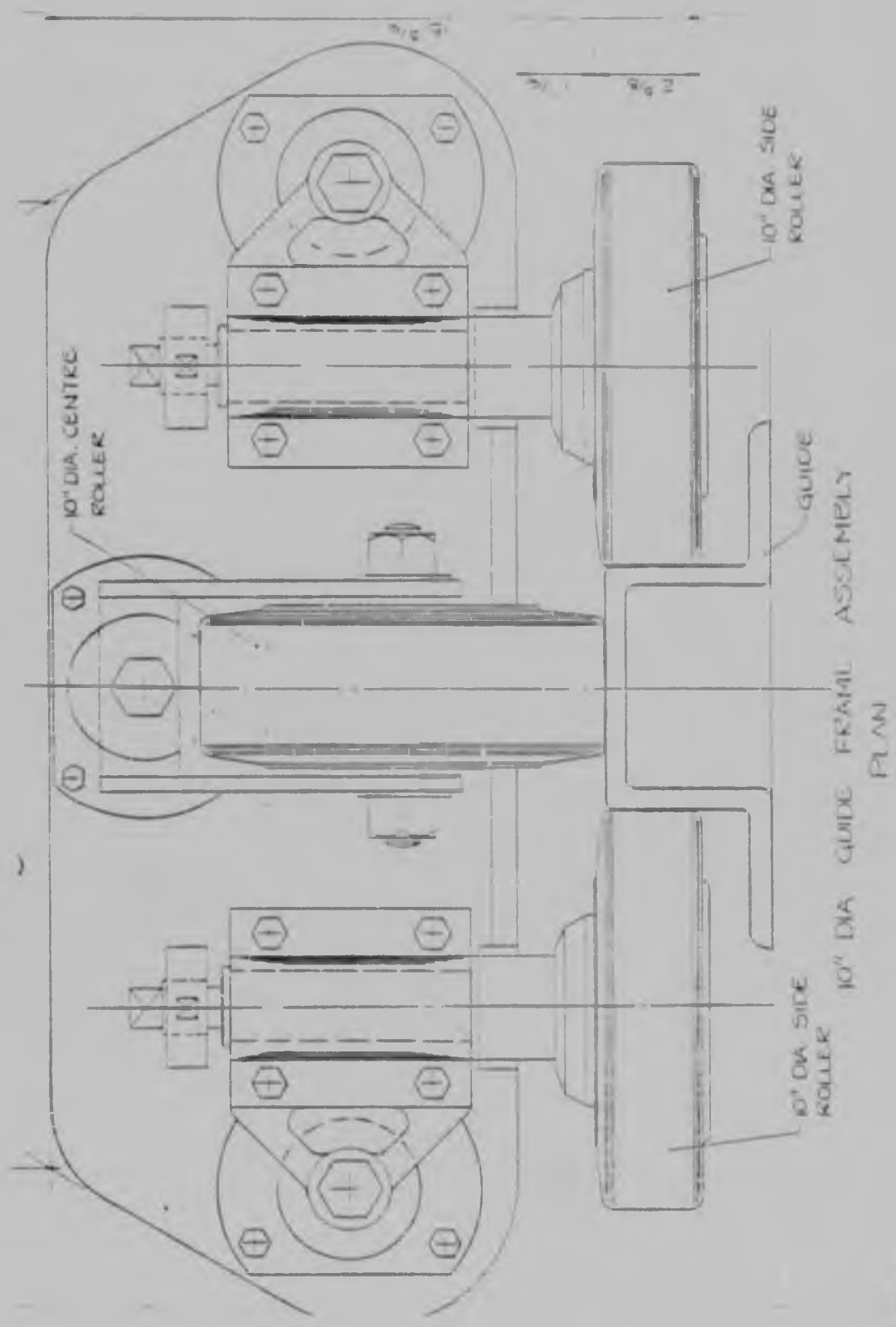

FIGURE 2.2 : 'PATENT PRODUCTS' GUIDE-ROLLER ASSEMBLY

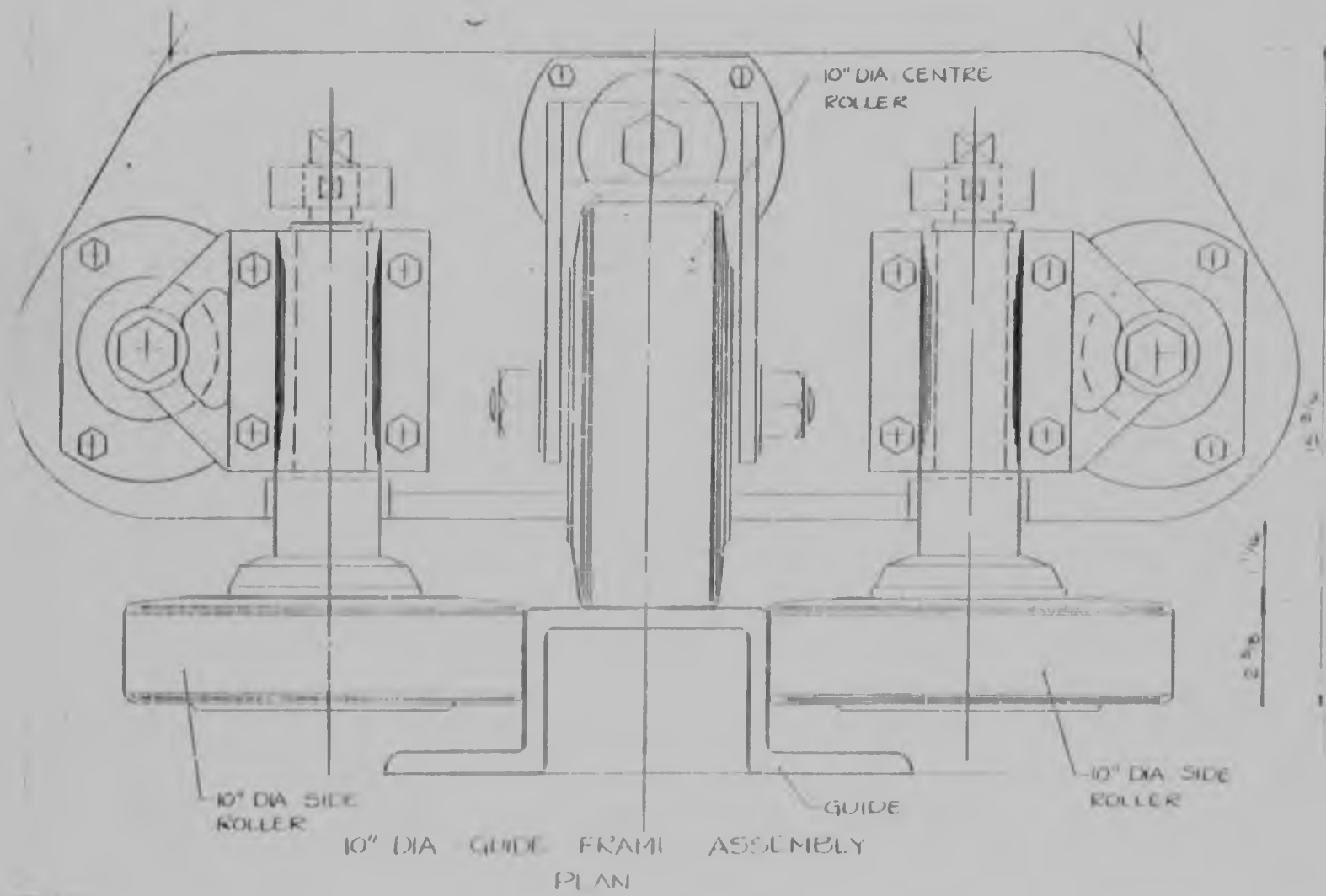
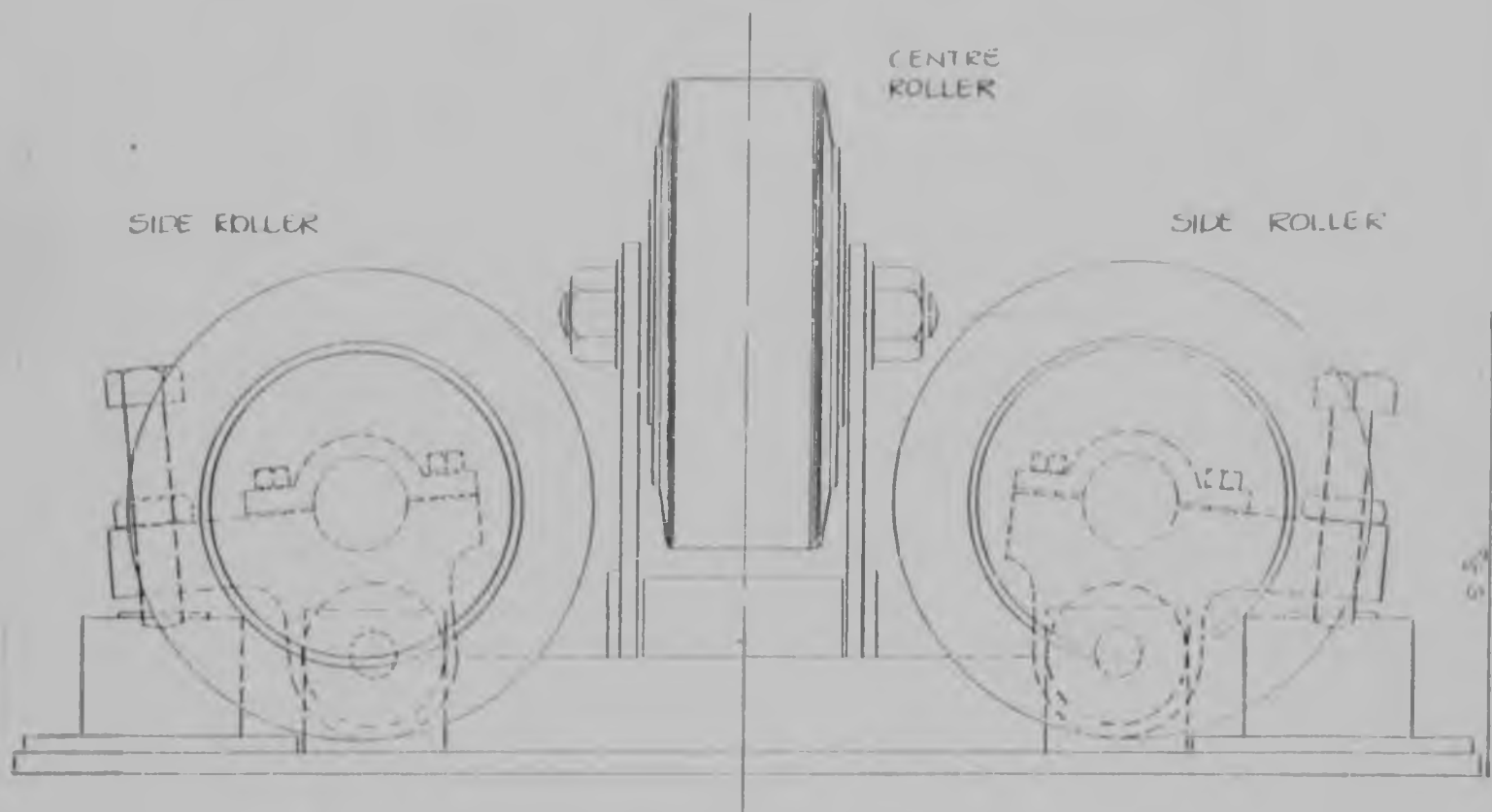
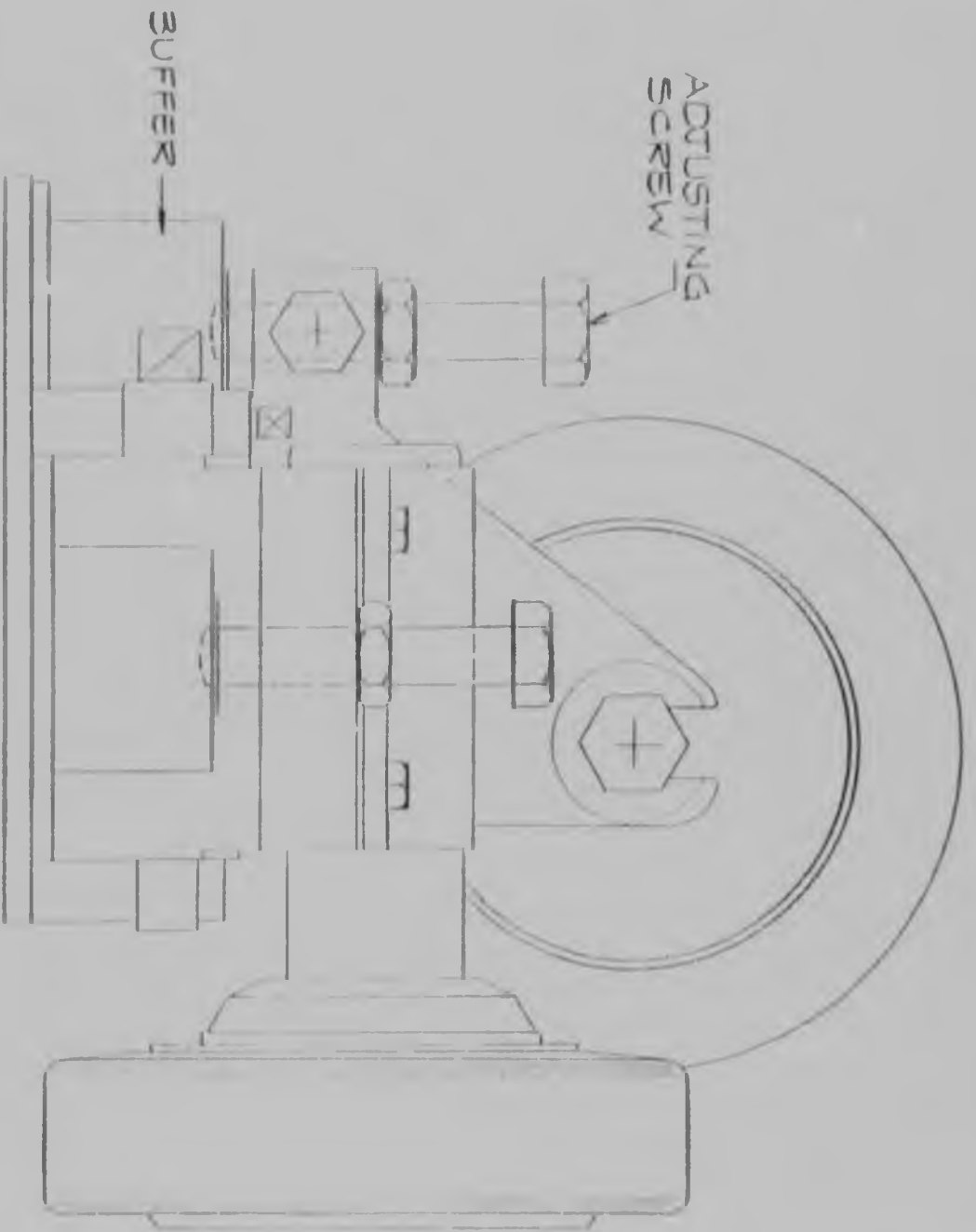

FIGURE 2.2 : 'PATENT PRODUCTS' GUIDE-ROLLER ASSEMBLY



10" DIA GUIDE FRAME ASSEMBLY  
FRONT ELEVATION

FIGURE 2.3 : 'PATENT PRODUCTS' GUIDE-ROLLER ASSEMBLY



10" DIA GUIDE FRAME ASSEMBLY  
SIDE ELEVATION

FIGURE 2.4 : 'PATENT PRODUCTS' GUIDE-ROLLER ASSEMBLY

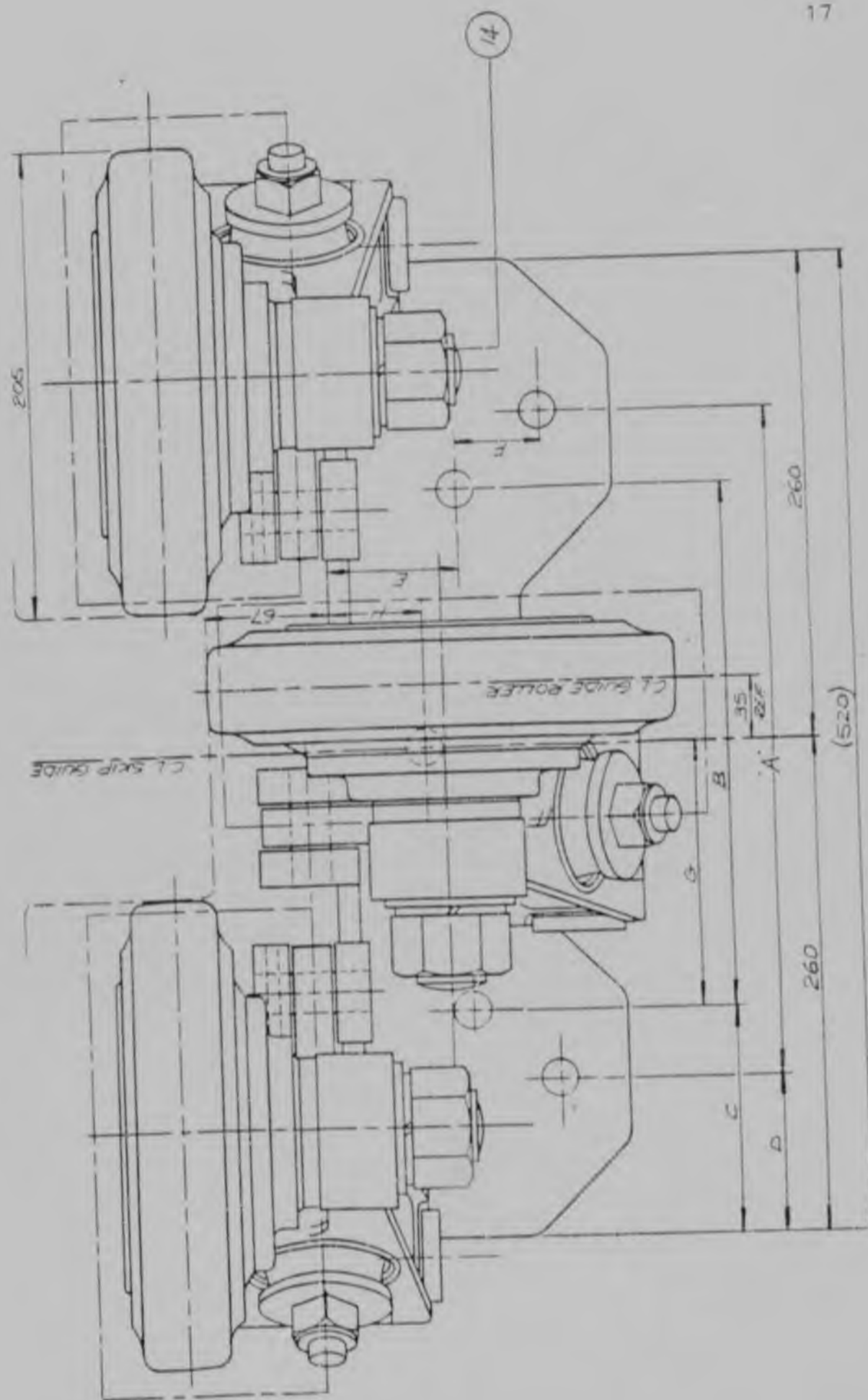

FIGURE 2.5 : PLAN OF 'SKF' TYPE GUIDE-ROLLER ASSEMBLY

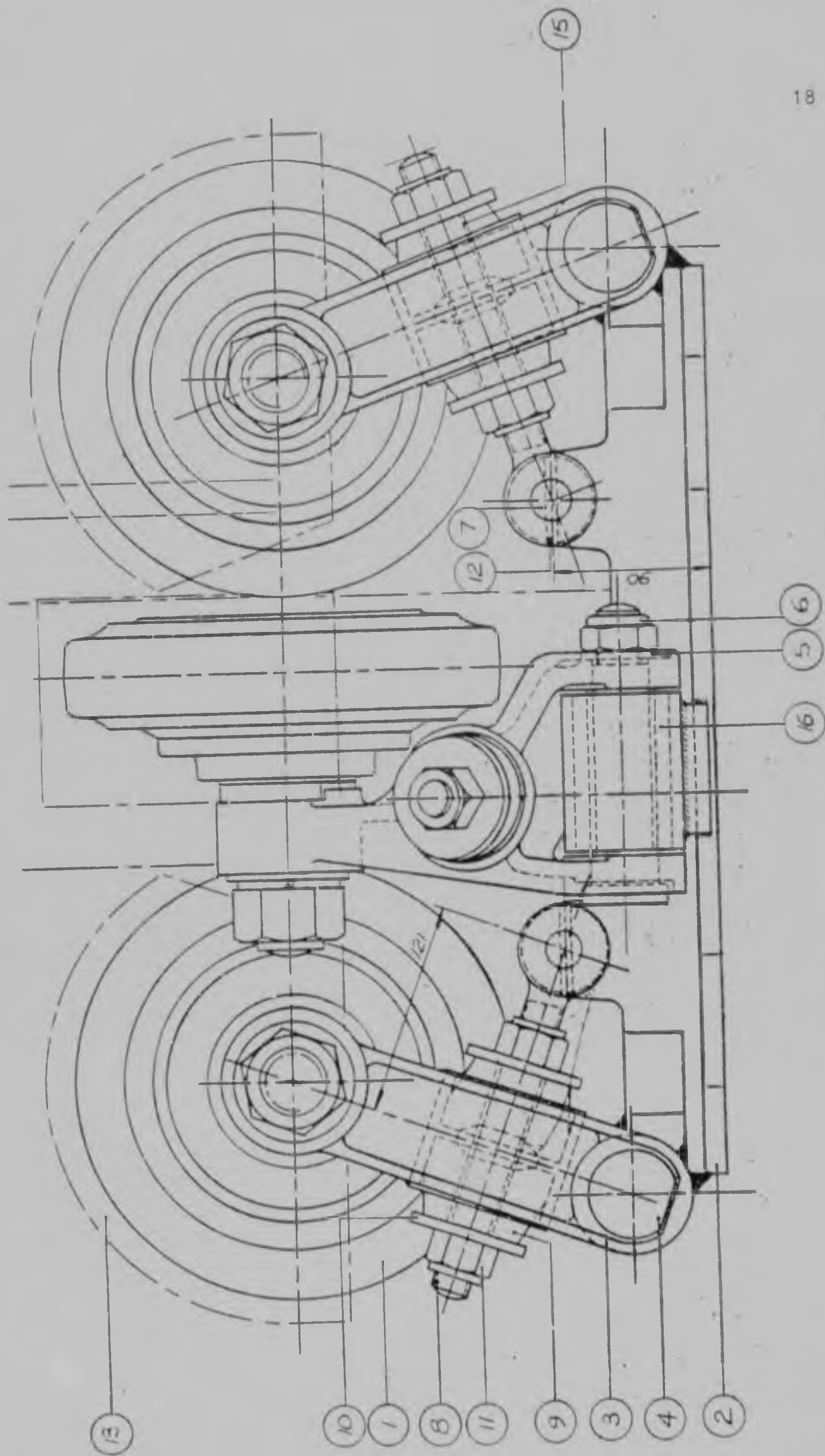
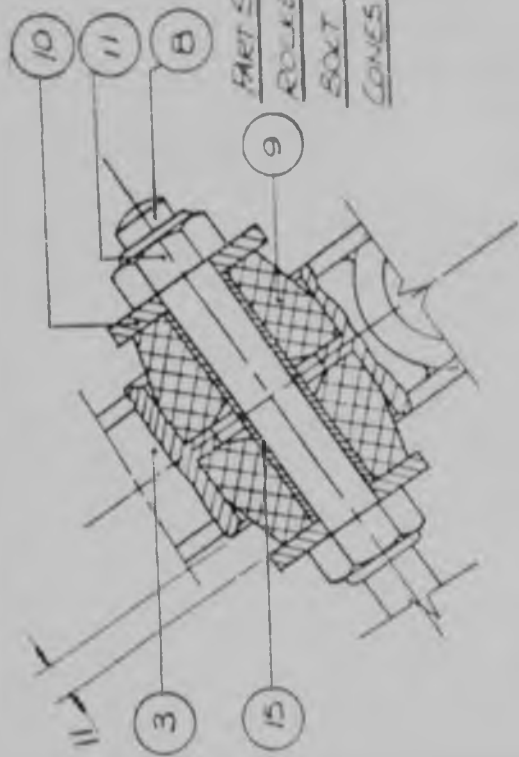
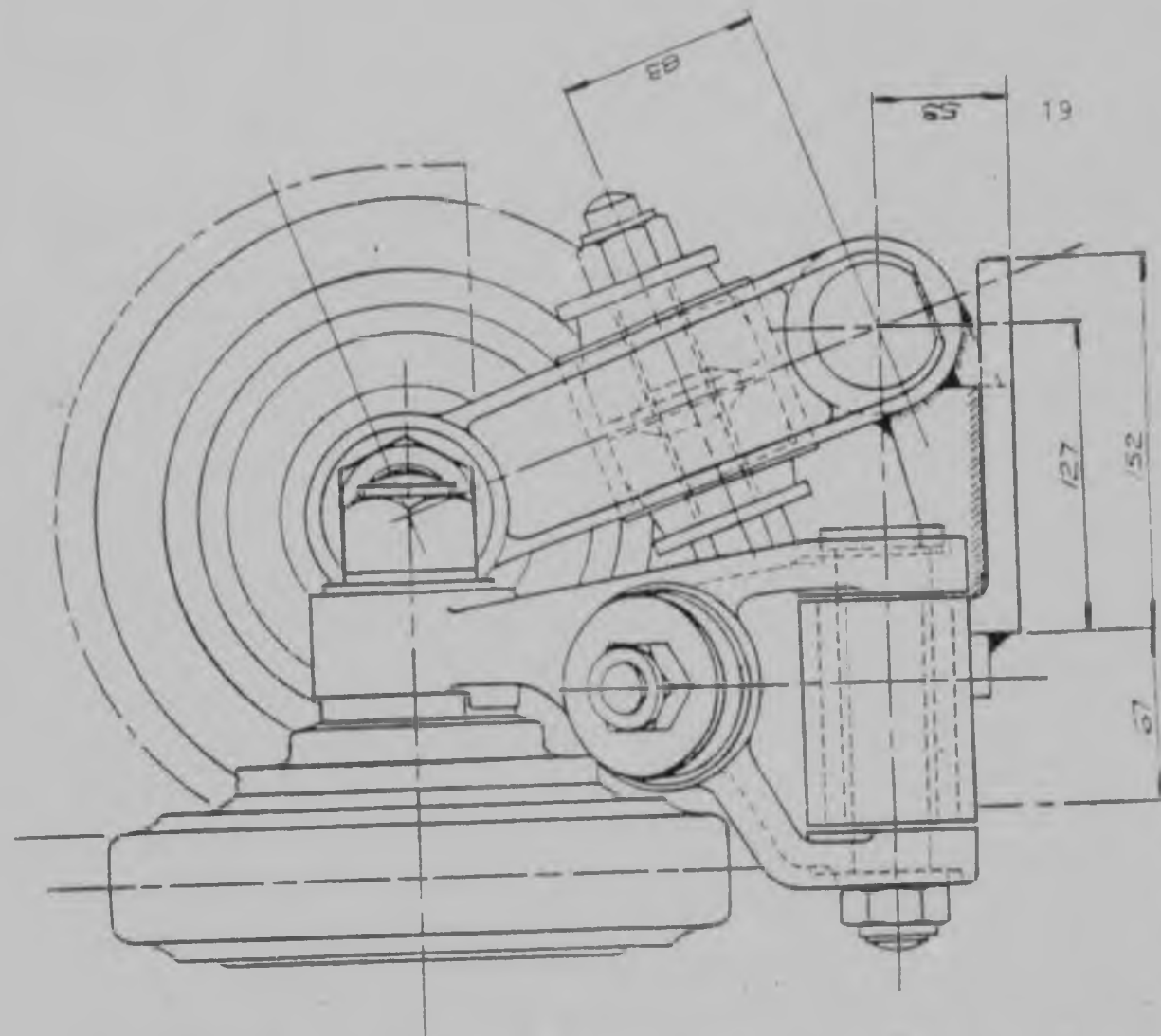

FIGURE 3.6 : FRONT ELEVATION OF 'SKF' TYPE GUIDE-ROLLER ASSEMBLY.



PART SECTION SHOWING  
ROLLER ARM AND EYE  
BOLT WITH RUBBER  
CONES ETC IN POSITION



PART NO.	QUANTITY	DESCRIPTION	MATERIAL	REFERENCE
16	3	SILENT BLOC (E 237)		773
15	3	SPACER TUBES		682
14	3	SPINDLE	EN 9 NORM	711
13	3	CONE	M15 FABRICATED	835
12	3	Ø 6mm CONICAL FIN	25mm LONG	953
11	6	M20 SIMMONDS NUT	TYPE T	915
10	6	WASHER	M15	944
9	6	RUBBER PAD	RUBBER	714
8	3	EYE BOLT	M15	905
7	3	EYE BOLT FIN	35-40 TENSILE ALLS STEEL	720
6	8	M24 SIMMONDS NUT	TYPE T	915
5	3	WASHER	M16	944
4	3	ROCKER ARM FIN	M16	943
3	3	ROCKER ARM	DUCTILE IRON	854
2	1	BRACKET	M15 STEEL FABRICATED	831
1	3	250mm GUIDE ROLLER	ROE SPINDLE SEE PART 14	635

FIGURE 2.7 : SIDE ELEVATION OF 'SRP' TYPE GUIDE-ROLLER ASSEMBLY

When this programme is applied to the short records in Figure 3.1, it will either count the small ranges in Figure 3.1a, or the large range in Figure 3.1b, but not both. Thus if the small ranges are damaging a situation results where in either case fatigue-loading will be underestimated.

As the large ranges are responsible for a major part of the fatigue damage it is vital that they are counted by any computer programme. Unfortunately this complicates the programme immensely especially where minor reversals occur in the load record.

At this point a discussion of the various cycle counting techniques and their merits is appropriate in order to indicate the background research into the computer programme.

#### 4. Cycle counting techniques

Six well-known cycle counting techniques are briefly summarized in Table 3.1, while the more accurate techniques are described subsequently. In general it can be said that the accuracy of the fatigue loading spectrum is directly proportional to the degree of difficulty experienced in the cycle-counting technique. However, as long as the cycles corresponding to the high load ranges are counted satisfactorily increased accuracy of the fatigue loading spectrum is often unnecessary as the low load ranges are responsible for a very small part of the total fatigue damage. It is for this reason that some of the cycle counting techniques described in Table 3.1 are used although the load spectrum obtained by using them is not very accurate.

However enough measurements of wheel load were obtained to provide useful information on the behaviour of mine-shaft steelwork.

## 2.7 Load Cells for 'Patent Products' guide wheels

### 2.7a Adjusting screw type load cell

A suitable method of introducing a load cell in this guide assembly was found to be by making up load cells in the form of the adjusting screw shown in Figure 2.4 and then using this load cell to replace the adjusting screw during the test measurements.

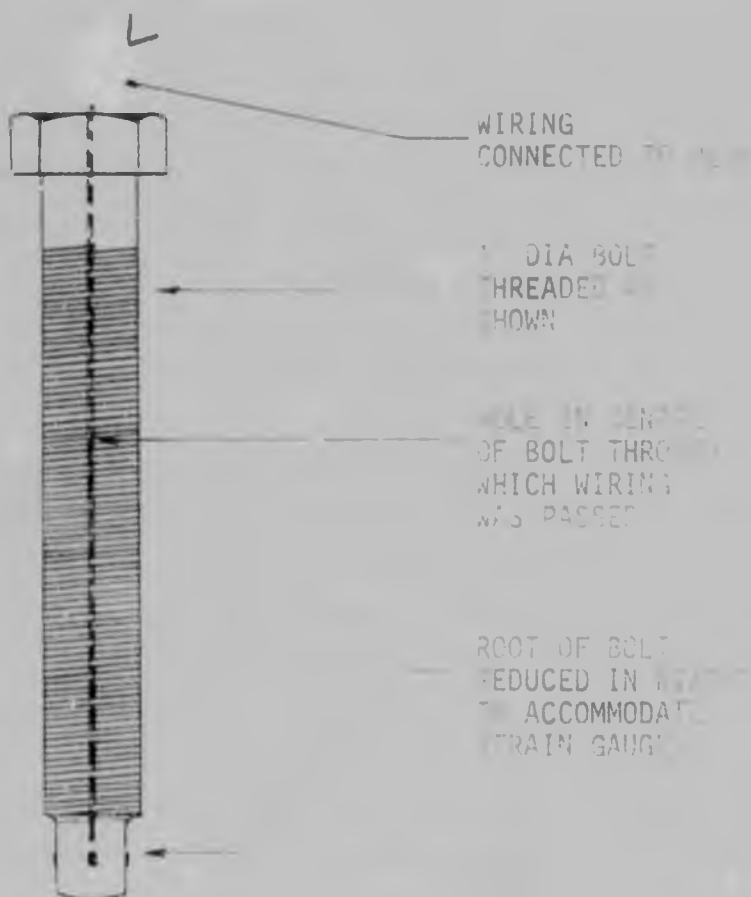

FIGURE 2.4. ADJUSTING SCREW TYPE LOAD CELL

The load cell is shown in Figure 2.8. The root of the bolt was reduced in diameter and strain gauges were fixed onto this part. A hole was drilled through the centre of the bolt and the wiring from the strain gauges was taken through this hole into a plug as shown. After fixing the strain gauges onto the bolt and wiring, a durable glue was placed over the strain gauges in order to prevent damage to them during use in the mineshaft.

The main limitation with this type of load cell was that it could only be used in guide roller assemblies where the adjusting screw was 1" in diameter. This was not always the case and in some cases the adjusting screw was 25 mm in diameter while in others 20 mm. Also in using this load cell difficulties were encountered with removing the adjusting screw and then again when installing and removing the load cell. Because of the above problems, use of this type of load cell was very limited.

#### 2.7b Socket type load cell

This load cell was designed for the 'Patent Products' guide wheels in order to overcome the problems experienced with the adjusting screw replacement load cell. It is shown in Figure 2.9 and it was designed to be inserted between the adjusting screw point and the buffer (see Figure 2.4).

Again the strain gauges were covered with glue to prevent damage to them during use of the load cell.

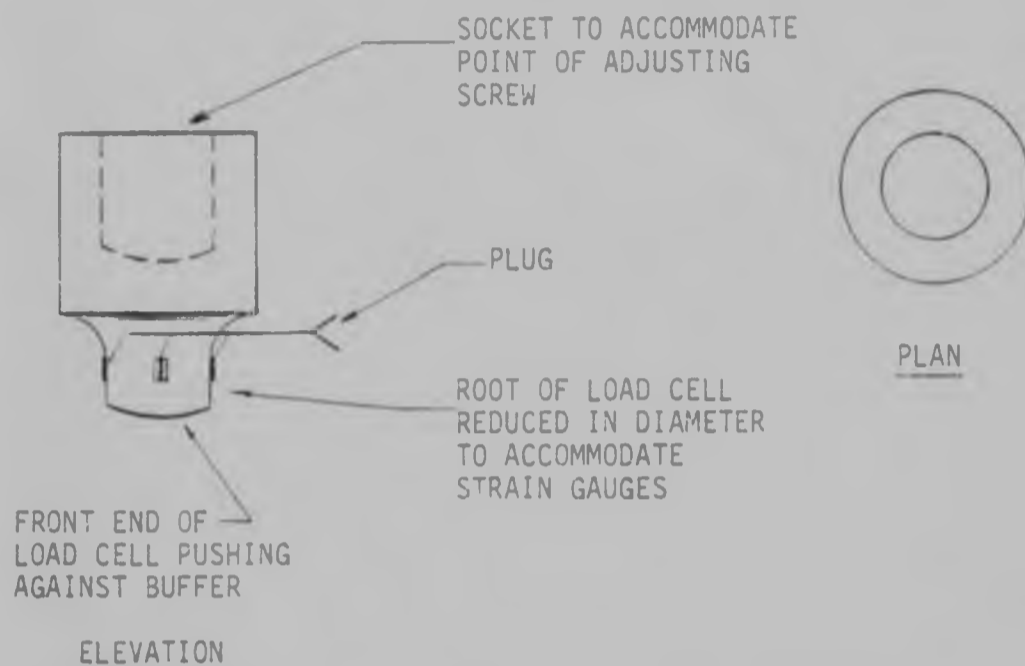

FIGURE 2.9 : SOCKET TYPE LOAD CELL

It was intended that these load cells would be used for all diameters of adjusting screw and, while this problem was solved, another was created, and that was, that because of its size it was not possible to insert the load cell between the adjusting screw and the buffer in some cases. On another occasion the load cell fell out when vibration of the conveyance reached a high level.

#### 2.8 Load cell for 'SKF' guide wheels

The load cell used for this assembly was again in the form of the adjusting screw, referred to as an eye bolt in this application and shown on Figure 2.6 part No. 8. It is illustrated in Figure 2.10.

The strain gauges were again protected from damage by a glue. These load cells were used twice only and in one model of the SKF guide assembly installation was quite simple while on another model installation was very laborious.

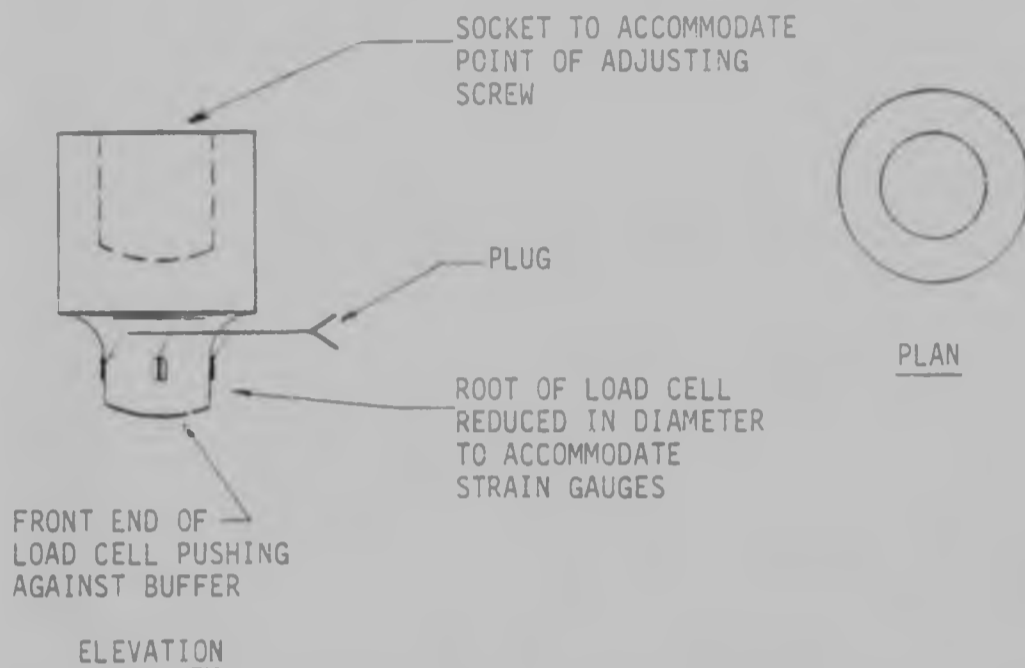

FIGURE 2.8 - SOCKET TYPE LOAD CELL

It was intended that these load cells would be used for all diameters of adjusting screw and, while this problem was solved, another was created, and that was, that because of its size it was not possible to insert the load cell between the adjusting screw and the buffer in some cases. On another occasion the load cell fell out when vibration of the conveyance reached a high level.

#### 2.8 Load cell for 'SKF' guide wheels

The load cell used for this assembly was again in the form of the adjusting screw, referred to as an eye bolt in this application and shown on Figure 2.6 part No. 8. It is illustrated in Figure 2.10.

The strain gauges were again protected from damage by a glue. These load cells were used twice only and in one model of the SKF guide assembly installation was quite simple while on another model installation was very laborious.

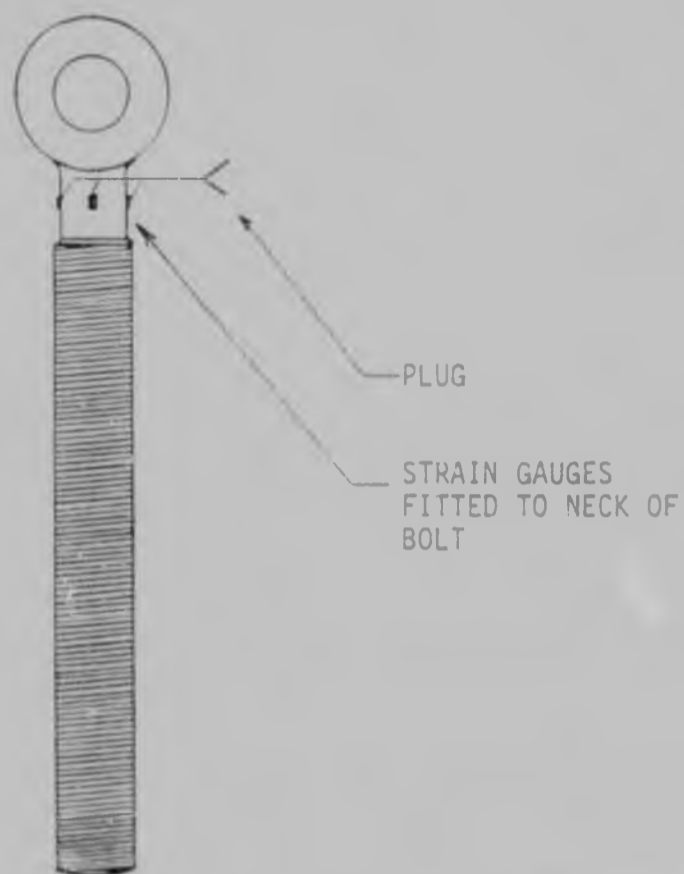

FIGURE 2.10 : LOAD CELL FOR 'SKP' GUIDE WHEELS

### 2.9 Calibration of the load cells

Calibration was necessary in order to relate the output voltage from the strain gauges to the wheel load. A number of factors had to be considered when deciding on how the calibration should be carried out.

These were the following:

- a) The load to be measured was dynamic and it was necessary to ascertain that the strain gauges exhibited the same behaviour under dynamic loading as under static loading.
- b) The condition of the guide-roller assembly could influence the results as it was possible that an old assembly could behave differently from a new one.

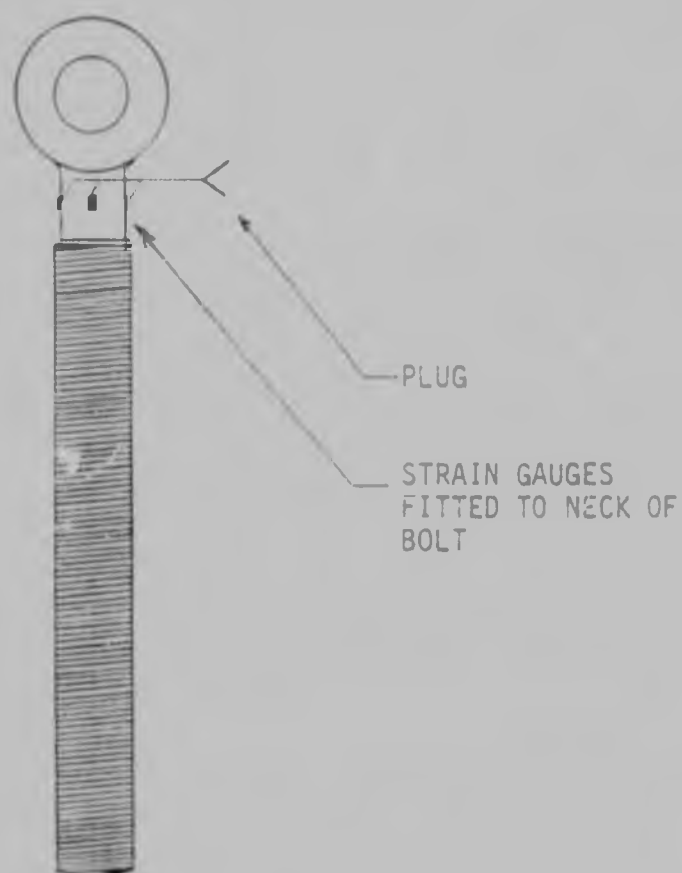

FIGURE 2.10 : LOAD CELL FOR 'SKF' GUIDE WHEELS

### 2.9 Calibration of the load cells

Calibration was necessary in order to relate the output voltage from the strain gauges to the wheel load. A number of factors had to be considered when deciding on how the calibration should be carried out.

These were the following:

- a) The load to be measured was dynamic and it was necessary to ascertain that the strain gauges exhibited the same behaviour under dynamic loading as under static loading.
- b) The condition of the guide-roller assembly could influence the results as it was possible that an old assembly could behave differently from a new one.

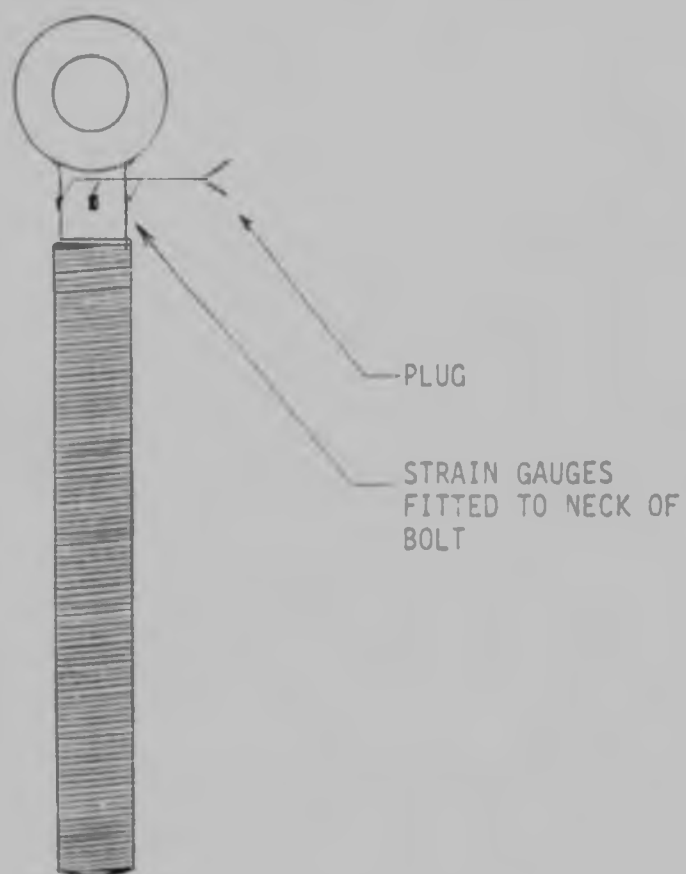

FIGURE 2.10 : LOAD CELL FOR 'SKF' GUIDE WHEELS

### 2.9 Calibration of the load cells

Calibration was necessary in order to relate the output voltage from the strain gauges to the wheel load. A number of factors had to be considered when deciding on how the calibration should be carried out.

These were the following:

- a) The load to be measured was dynamic and it was necessary to ascertain that the strain gauges exhibited the same behaviour under dynamic loading as under static loading.
- b) The condition of the guide-roller assembly could influence the results as it was possible that an old assembly could behave differently from a new one.

- c) The question whether laboratory calibration could be viewed as representative of conditions on site.

After consideration of the above factors it was decided that the following calibration procedure would enable these three effects to be assessed:

- a) Static calibration tests were carried out in the laboratory using a new and an old guide-roller assembly.
- b) A dynamic calibration test was carried out in the laboratory using one of the load cells.
- c) Static calibrations were carried out on site in certain shafts.

As it became obvious that calibration for a load cell in a certain guide roller assembly was similar under all conditions the dynamic and site calibration were dispensed with after a while.

#### 2.10 Static calibration tests

For the purpose of these calibrations a new and an old 'Patent Products' guide roller assembly were used. The calibrations were carried out on four different load cells of the adjusting screw type (Figure 2.8) and the results obtained are shown in graph form in Figures 2.11 to 2.14. The following important observations can be made from these graphs:

- a) The relationship between the wheel load and the voltage output from the strain gauges is practically linear.

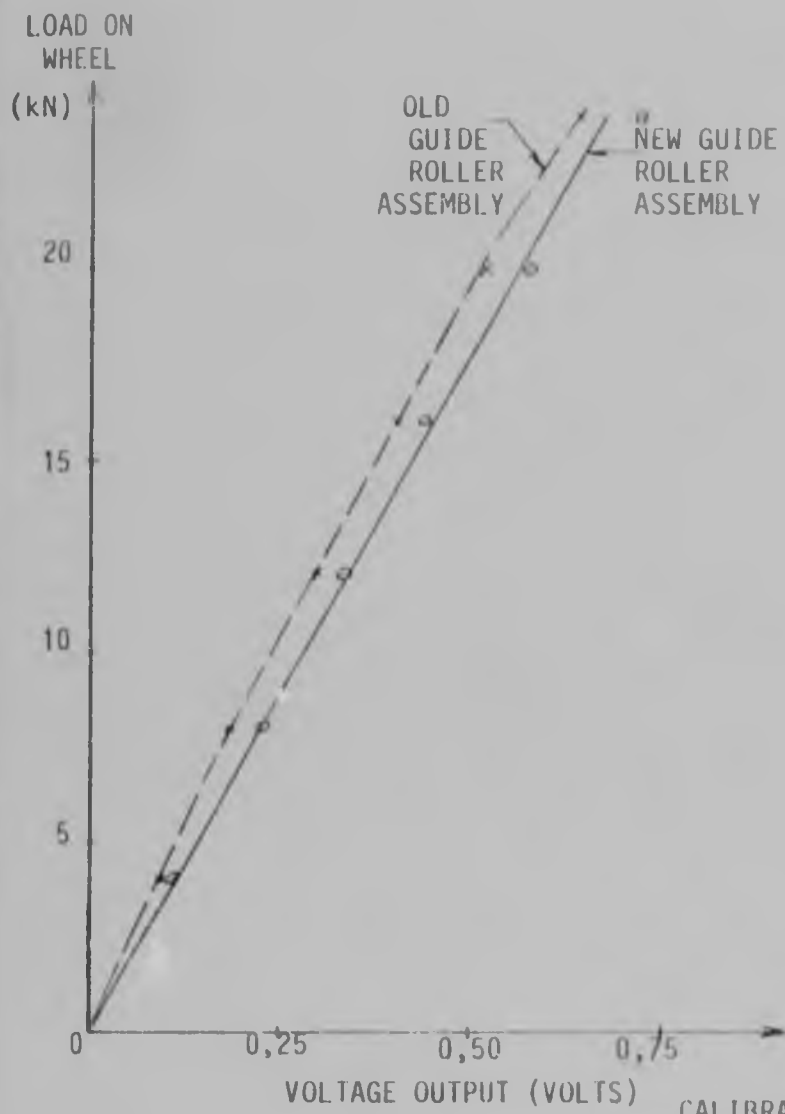

FIGURE 2.11 : LOAD CELL NUMBER 1

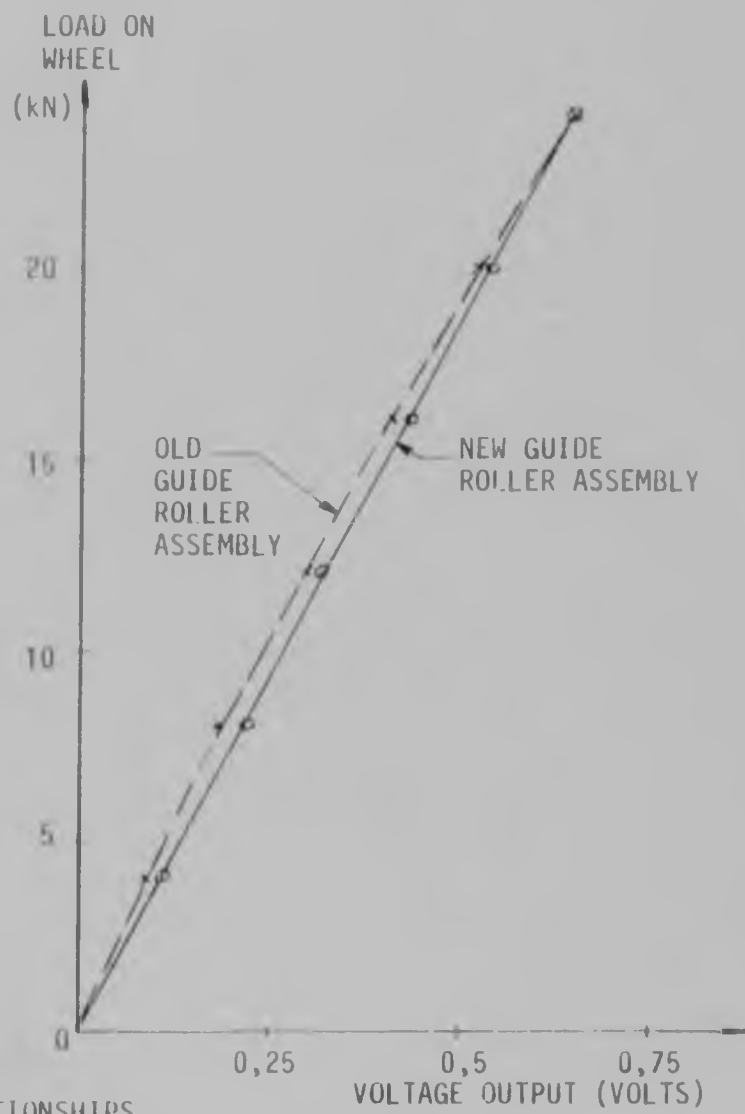

FIGURE 2.12 : LOAD CELL NUMBER 2

CALIBRATION RELATIONSHIPS

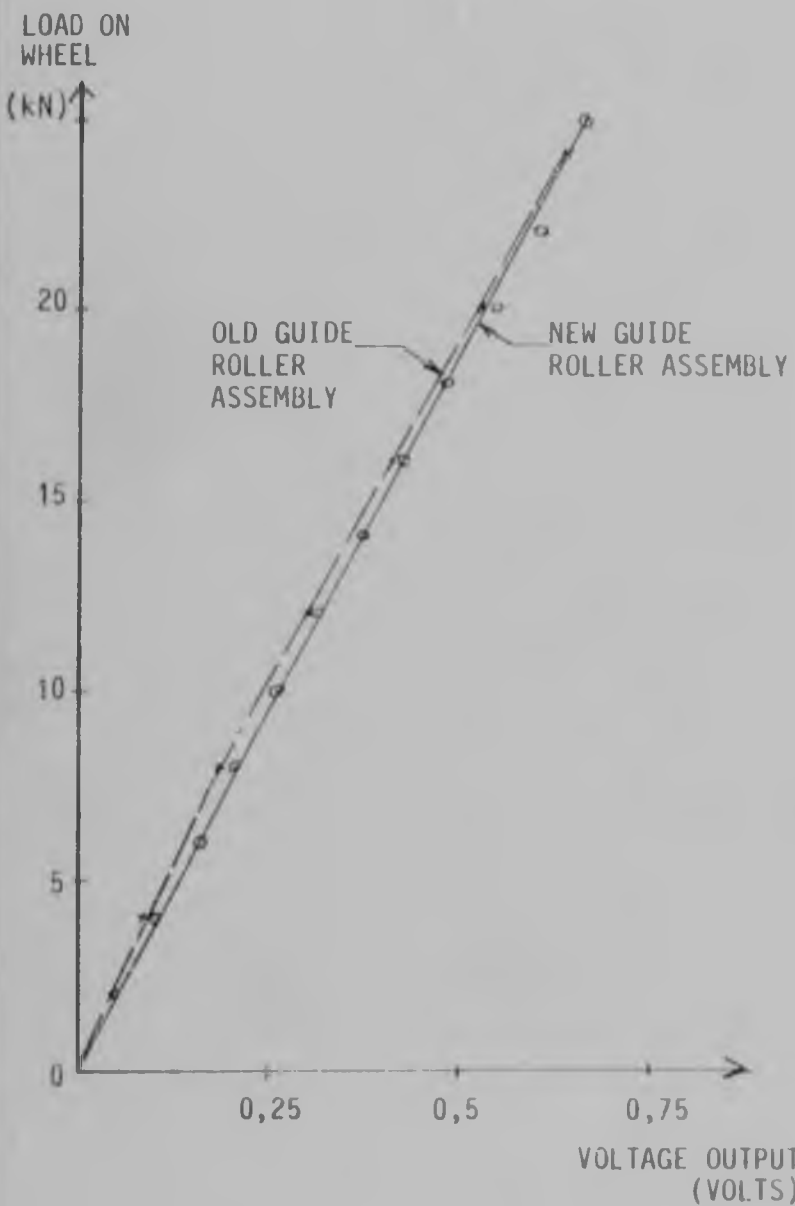

FIGURE 2.13 LOAD CELL NUMBER 3

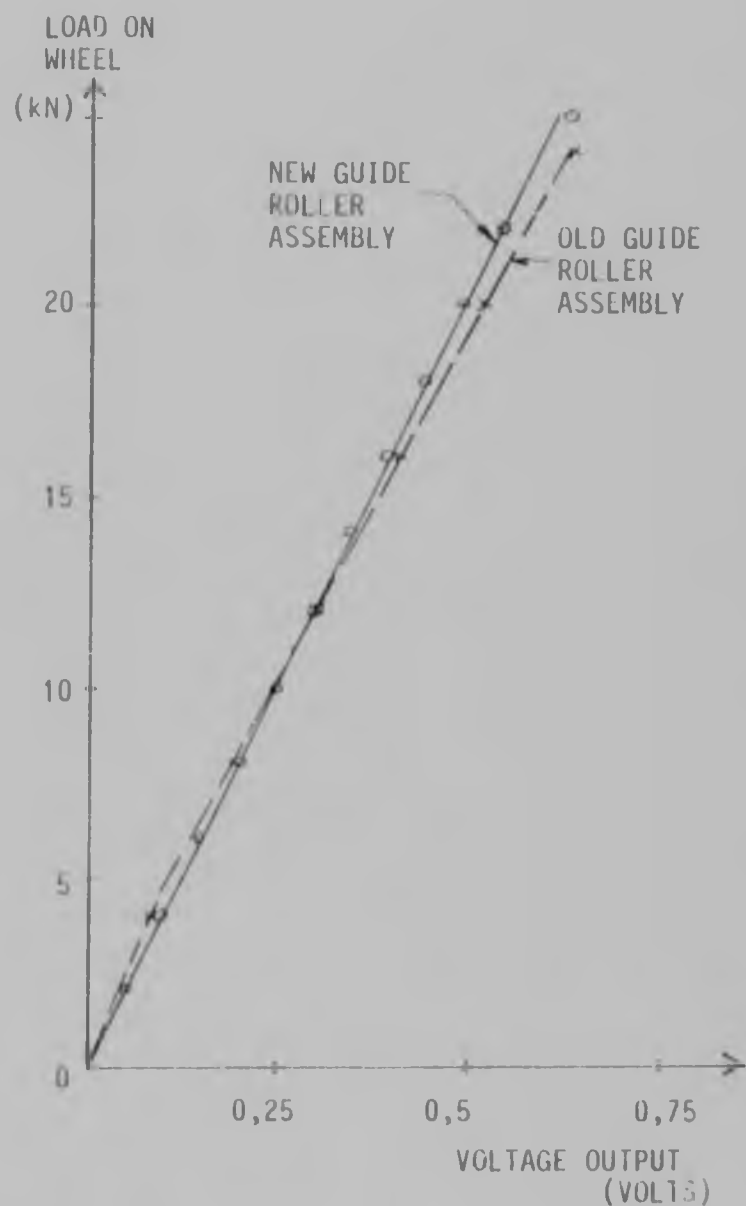

FIGURE 2.14 LOAD CELL NUMBER 4

CALIBRATION RELATIONSHIPS

- b) There is practically no difference in behaviour between the new and the old wheels.
- c) The same calibration constant applies to all four load cells.
- d) In addition it was found after obtaining the relationship between the load in the cell and the voltage output from the strain gauges, in a direct compression test on the cells alone, that the force in the adjusting screw can be obtained from the wheel load by considering equilibrium conditions and neglecting friction in the bearing.

After these findings it was reasonable to assume a linear relationship between wheel load and output voltage especially as this simplified calibration of the varying load considerably.

The best straight line plot representing this relationship is one with a slope of 0,026V/kN. All calibration test readings lie within 1,5 standard deviations away from this line (giving a confidence limit of over 95%) and the coefficient of variation at all load levels is less than 0,1.

For the eye bolt type tension load cells (Figure 2.10) the relationship between load and voltage output was 0,021V/kN and for the socket type load cells 0,022V/kN.

#### 2.11 Site calibration of load cells

This was a static calibration conducted on site. It was carried out as a check calibration in order to verify mainly that local conditions in a mineshaft did not influence wheel load measurement and that

laboratory calibration could be used for obtaining the wheel load.

It was conducted using a plate especially made up in the laboratory for this purpose. The plate, shown in Figure 2.15 was 350 mm long x 100 mm wide x 10 mm thick. Two half rounds were bolted to it as shown in the figure leaving a gap of 7,5 mm between the soffit of the plate and the surface it was placed on. When loaded with a guide wheel at its midspan a load of 1,5 kN was required to reduce the gap to 2,5 mm (i.e. deflection of the plate at its midspan is 5 mm). The strains were still in the elastic range at this stage.



FIGURE 2.15 : Calibration plate

On site this plate was inserted vertically between the guide wheel and the guide, such that the centreline of the plate lined up with the centreline of the guide wheel, after the load cell had been installed in the guide-roller assembly. The preload on the wheel was increased until the deflection of this plate was 5 mm (i.e. gap between soffit of plate and guide was 2,5 mm corresponding to an applied load of 1,5 kN). The output voltage from the strain gauges in the load cell was recorded after which the plate was removed.

Although this calibration involved quite a simple procedure it was very awkward to carry out in most of the mineshafts. The main reasons for this were, firstly, because it was time consuming especially when applied on all four guide wheels and secondly because of installation considerations when the calibration plate could not be fitted between the guide and guide wheel, or, when fitted, could not be loaded through the guide wheel because of insufficient length of the adjusting screw in the guide-roller assembly.

However, it was discovered relatively early, after a few site calibrations, that local conditions in a mineshaft did not affect load measurement, as the recorded load was similar to the expected load. Calibration relationships obtained from the site calibrations for the socket type load cell were in the range between 0,0228 - 0,0235 V/kN which is within 7% of the calibration constant of 0,022 V/kN established in the laboratory. As a result the site calibration procedure was discontinued after the earlier tests were completed.

#### 2.12 Dynamic calibration

After it was established that static calibration of the load cells was constant under all static conditions it was necessary to carry out a dynamic calibration since the loads measured by the load cells were always dynamic in nature. The strain gauges in the load cells were not prone to dynamic excitation and thus it was unlikely that the load cells would exhibit different dynamic calibrations but this had to be verified experimentally.

The only machine available in the laboratory for this purpose was a fatigometer which was not actually ideal for this type of calibration. Nevertheless this

machine was used and the calibration procedure was carried out by inserting a socket type load cell in a 'Patent Products' guide roller assembly which was placed in a suitable frame and loaded by the fatiguemeter. Tests at two loading levels were carried out which approximately represented the limits of the machine. The first loading arrangement was a sinusoidal load of frequency 0,7hz and amplitude of 9 kN (range from 4,5 kN to 13,5 kN). The second loading arrangement was also a sinusoidal load of frequency 1,85 hz and amplitude 4 kN (range 4,5 kN to 8,5 kN).

The output obtained from the load cell is shown in Figures 2.16 and 2.17.

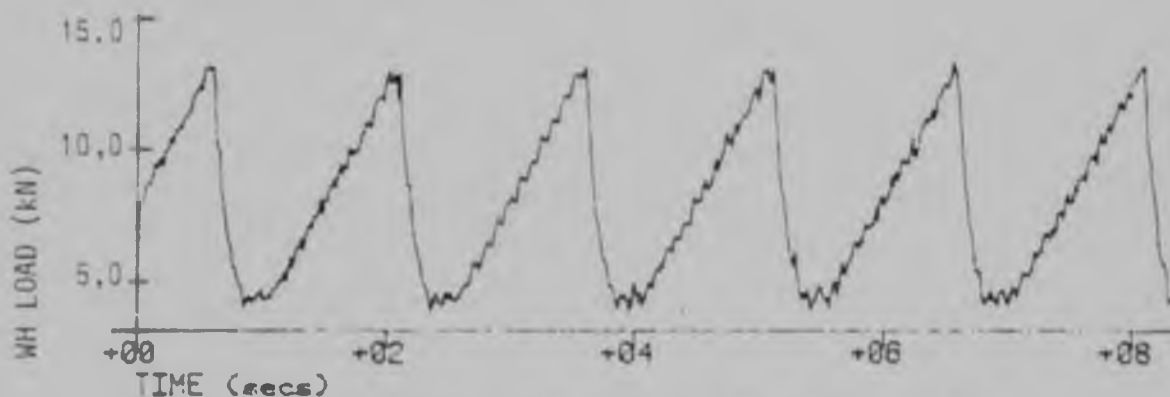

FIGURE 2.16 : Dynamic calibration at frequency of 0,7 hz  
and amplitude of 9 kN  
(Applied load fluctuates 4,5-13,5 kN)

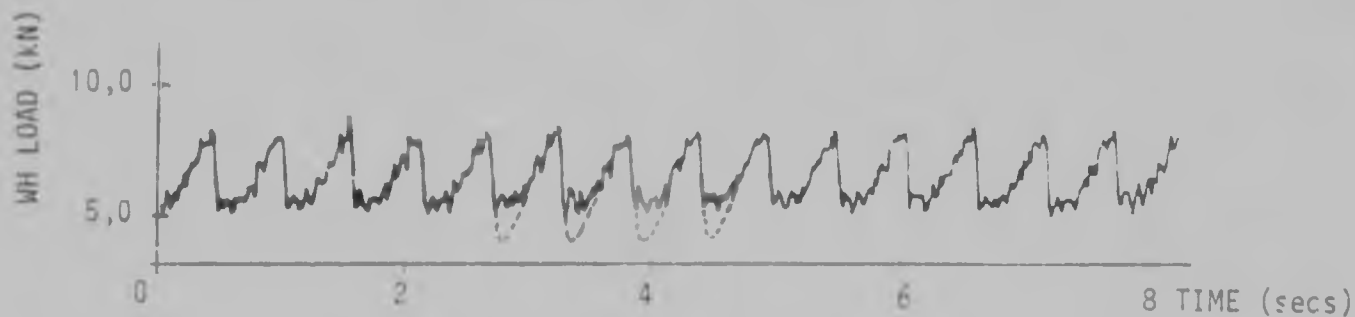

FIGURE 2.17 : Dynamic calibration at frequency of 1,85 hz  
and amplitude of 4 kN.  
(Applied load fluctuates 4,5-8,5 kN)

The plots shown in Figures 2.16 and 2.17 yield the following calibration relationships:

<u>Frequency</u>	<u>Calibration constant</u>
0,7 hz (Figure 2.16)	0,0205 Volt/ <sub>kN</sub>
1,85 hz (Figure 2.17)	0,017 Volt/ <sub>kN</sub>

The results do not appear to be very successful at first glance but the following comments are appropriate here:

- a) The minor reversals in the rising portion of the load cycle are probably due to the forward and reverse action of the ram in the hydraulic jack when building up pressure.
- b) For the 0,7 hz test the relationship of 0,0205 Volt/<sub>kN</sub> agrees reasonably with the one obtained for the static calibration test (0,021 Volt/<sub>kN</sub>). However for the 1.85 hz test this is not the case. The main reason for this could be that because of the high frequency there is overlap between the falling and the rising portions of the load cycle in the fatiguemeter preventing the execution of complete cycles as indicated by the dotted lines in Figure 2.17. This view is supported firstly by the fact that there is a prolonged level portion at the low load level (which is very much less evident in Figure 2.16) and secondly because the low load level of 4,5 kN (which is identical in Figure 2.16 and Figure 2.17) does not plot at the same point on the vertical axis.
- c) If it is assumed that the complete cycle is as shown by the dotted lines in Figure 2.17 with the 4,5 kN plotted at the same point on the vertical axis as for

Figure 2.16 then the relationship between the voltage output level and wheel load is 0,0215 Volt/kN which is again similar to the static calibration relationship.

On the above basis it may be assumed that the static and dynamic calibrations of the load cells do not differ significantly although it must be acknowledged that the dynamic calibrations did not cover the range or significant frequencies measured in the actual shafts.

### 2.13 Performance of the load cells

Measurement of the guide-wheel loads was a fairly complicated and time-consuming procedure even when carried out under the most favourable conditions. Unfortunately as it turned out conditions for measuring the wheel loads were not always favourable. There were various reasons for this, the most important being the fact that just about every shaft used its own version of a standard guide roller assembly which made installation of the load cells intended for the standard assemblies extremely difficult if not in some cases impossible. This problem was compounded by the great distances travelled between the University and the various mineshafts and the time available for measurements. This meant that firstly it was almost impossible to carry out thorough research into the conditions pertaining at the shaft. Secondly there was no room for trials (and subsequent modification) and, as a result, if last minute problems were encountered, they could often not be solved on site and the tests proceeded without measurement of all the wheel loads rather than be aborted altogether.

Another problem which was encountered in a few mineshafts was that installation of certain load cells

interfered with the proper operation of the conveyance and as a result they had to be removed.

Nevertheless despite these setbacks the measurement programme was reasonably successful as wheel load records were obtained from eight different shafts and records of lateral accelerations which formed part of the measurement programme were obtained from all the shafts. The load cells performed satisfactorily presenting no problems and yielding continuous records of wheel loads which provided valuable information on the dynamic behaviour of the shaft steelwork.

Figure 2.18 shows part of a record of a wheel load obtained from President Steyn Number 4 shaft (10T skip hoisting at 15,2 m/s).

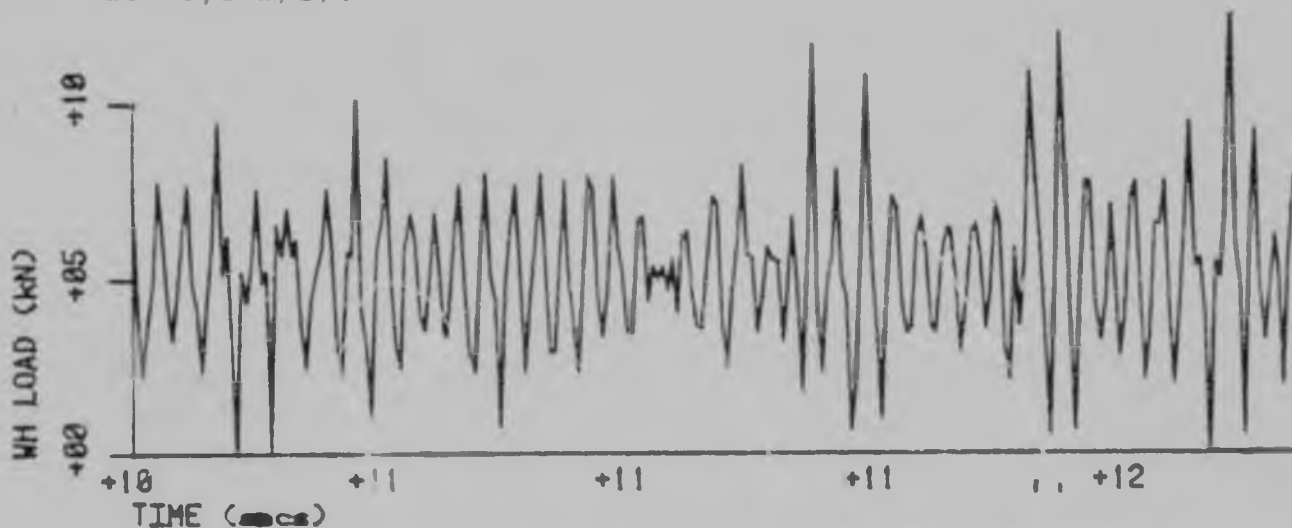

FIGURE 2.18 : Wheel load record, President Steyn No. 4 Shaft  
10T skip hoisting at 15 m/s

#### 2.14 Analysis of measured wheel loads

The measured wheel load data were subjected to various types of analysis in order to assess the results properly and draw conclusions from them. The following work has been carried out, and is reported by Krige<sup>1</sup>.

- a) A probability analysis was performed on the maximum wheel load per buntion interval and the expected maximum wheel load with a 99,9% probability of non-exceedence and expected maximum wheel load in one week of operation were found. Values differed over various shafts but in all cases the one-week maximum load was at least 35% below the value of  $W/10$  ( $W$ =weight of conveyance plus payload if any).
- b) A spectral analysis was carried out on the data to obtain frequency characteristics and phase information. Krige<sup>3</sup> found that the significant frequencies were of two types. The first type, below 5 hz, were not velocity dependent and were probably the natural frequencies of the conveyance. The second type of frequencies were proportional to the velocity, and the major frequency in this group was that of revolution of the guide wheels, while the frequency of passing buntions was not evident in most cases.

In addition fatigue analysis of the wheel loads was carried out and is described in Chapter 4 of this dissertation.

Krige<sup>3</sup> has concluded the following from his analysis:

- a) The current design load of  $W/10$  should be maintained.
- b) In general there was no significant difference between the wheel loads on conveyances travelling up or down.

- c) There was also no significant difference between wheel loads on empty or fully loaded conveyances.
- d) In general on skips the bottom wheel loads are higher than the top wheel loads.
- e) High preloads did not reduce the level of vibration but had the effect of increasing the predicted wheel loads.
- f) The variation of the wheel load with hoisting velocity can be represented by:

$$\text{WHEEL LOAD} = \frac{W}{10} \times \frac{(V+10)}{25}$$

Where W = Weight of conveyance when fully loaded  
V = hoisting velocity

## CHAPTER 3 : FATIGUE ANALYSIS

### 3.1 Introduction

The aim of this part of the project was to obtain fatigue-loading spectra from the records of wheel load measurement, both theoretical and experimental, which spectra could be used as design criteria for the fatigue analysis of shaft steelwork and in addition to compare the loading spectra predicted theoretically by the DISCS model to those obtained from the experimental measurements.

One of the important developments of this project was that continuous records of the wheel loads were obtained under operating conditions of the shaft and this meant that information could be gained regarding the real fatigue loading spectrum applied at the guide wheels of the conveyance.

As yet it appears that there is no universally accepted method of deriving the fatigue loading spectrum from a load record of a random nature. Various methods<sup>10</sup> are used which can be broadly grouped into two categories. The first category comprises the statistical methods which have recently been developed<sup>10</sup> for deriving the fatigue loading spectrum from the power spectrum of the load record. These methods are applicable only when the random load can be described by statistical parameters and at present have only been developed for cases in which the random load can be described by a normal distribution. These methods are rather complex involving the evaluation of statistical parameters and

the results obtained by using them are not very accurate at present.

The second category comprises the cycle-counting methods which have been used most commonly up to now for conventional fatigue applications. There are several cycle counting techniques that can be used for obtaining the fatigue loading spectrum from a load record but in general the methods that are easy to apply have serious shortcomings which cause an innaccurate assessment of the fatigue damage, while cycle-counting techniques which give an accurate assessment of the fatigue loading spectrum are quite cumbersome to apply, especially where long records are involved.

In this project it appears that the wheel load is not random, being influenced by the bunton spacing and rotating frequency of the wheels making the statistical methods almost non-applicable. In addition when considering the inaccuracies associated with the statistical methods it was clear at this stage that a method involving an appropriate cycle counting technique was most suitable for deriving the fatigue loading spectrum from the wheel load records.

### 3.2 Derivation of the fatigue loading spectra from the load records

Having decided that this was to be carried out using a cycle-counting technique it was further necessary to develop a computer programme for this purpose. The reasons for this were twofold: firstly the load records were available on tape and secondly the records were quite long making manual derivation of the fatigue loading spectrum almost impossible.

A literature survey showed that very limited information

was available on this subject mainly because comprehensive records of continuous load measurement were not easily obtainable. However one computer programme that became available had a serious flaw which is immediately apparent when the two load records in Figure 3.1 are examined.

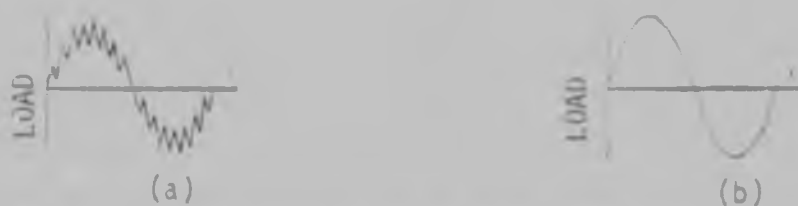







FIGURE 3.1 : Load records which test efficiency of a computer programme

This particular programme operated in the following manner:

- a) The maximum and minimum peaks in the record were found by locating all points of slope reversal.
- b) The load range in each case was taken as the greater of the two values found by subtracting the maximum peak value from the adjacent minimum peak values or vice versa in a manner analogous to the range cycle-counting method described subsequently.
- c) A minimum value of the range was required by the programme, and ranges below this minimum value were not counted as cycles, and the peaks corresponding to these ranges were disregarded. The intention here was to exclude ranges which were below the fatigue limit of the material thus ignoring minor reversals in the record which have the effect of breaking down the large ranges.

TABLE 3.1 : CYCLE COUNTING METHODS <sup>11</sup>

NAME	EXAMPLE	DESCRIPTION	COMMENT
PEAK		All maxima above the mean and all minima below the mean are counted. A cycle is completed by a max. and a min. of equal value.	It is assumed that all peaks are variations which start from the mean.
MEAN CROSSING PEAK		Only the largest peak between successive crossings of the mean is counted. Max. and min. peaks of equal value are combined to complete cycles.	Secondary cycles above and below the mean are ignored
LEVEL CROSSING		All positive slope level crossings above the mean, and negative slope level crossings below the mean, are counted	This method is not very accurate unless only one frequency is present
FATIGUE-METER		Similar to level crossing except that a count at a certain level is only made after the load crosses a preset level in the opposite direction	An improvement on the level crossing method although same comment applies to a lesser extent
RANGE		Each range i.e. the difference between successive peak values is counted as 1 cycle	If small reversals are counted the large ranges are broken up and counted as several smaller ones
RANGE MEAN		Ranges are counted as above and the mean value of each range is also noted.	As for range count method <sup>4</sup>

### 3.4 Range-pair counting method<sup>11</sup>

In the range-pair counting method the large load ranges as well as the small reversals superimposed on them are counted as cycles. A range is counted as a cycle if it can be paired with a subsequent loading of equal magnitude in the opposite direction.

The method is illustrated in Figure 3.2. The counted ranges are indicated by solid lines and the corresponding paired ranges with dashed lines. Each peak is considered in order as the initial peak of the range, except that a peak is skipped if the part of the history following it has already been paired with a previously counted range. If the initial peak of a range is a minimum, a cycle is counted between this minimum and the greatest maximum which occurs before the load reaches a value which is less than the initial peak of the range. For example in Figure 3.2 a cycle is counted between peak 1 and peak 8, peak 8 being the greatest maximum before the load reaches a value less than peak 1. If the initial peak of the range is a maximum, a cycle is counted between this maximum and the least minimum occurring before the load reaches a value which is greater than the initial peak of the range. For example in Figure 3.2 a cycle is counted between peak 14 and peak 15, peak 15 being the least minimum before the load becomes greater than peak 14.

Each range that is counted is paired with the subsequent loading of equal magnitude in the opposite direction as shown in Figure 3.2 where part of the range between peaks 18 and 25 is paired with the range counted between peaks 13 and 16.

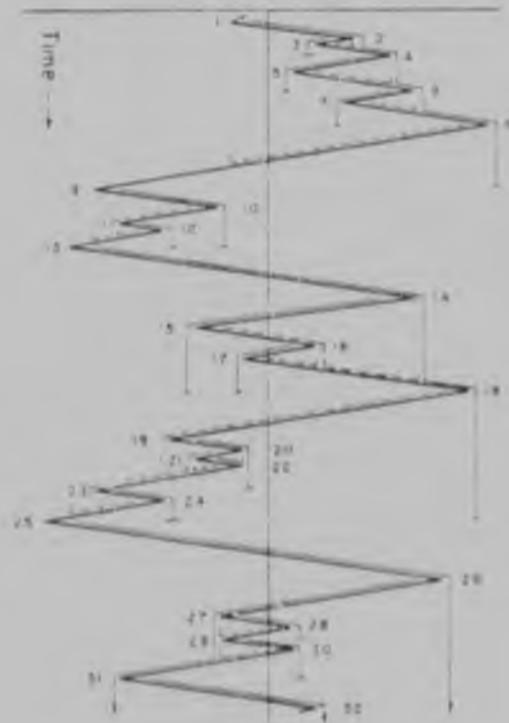

FIGURE 3.2 : Example of range-pair cycle counting method

### 3.5 Rainflow cycle-counting method<sup>11</sup>

This method was recently developed in Japan and corresponds to the cyclic stress-strain response of the material. It is illustrated in Figure 3.3. The record is plotted with the time axis vertically downward and the lines connecting the load peaks are imagined to be a series of pagoda roofs.

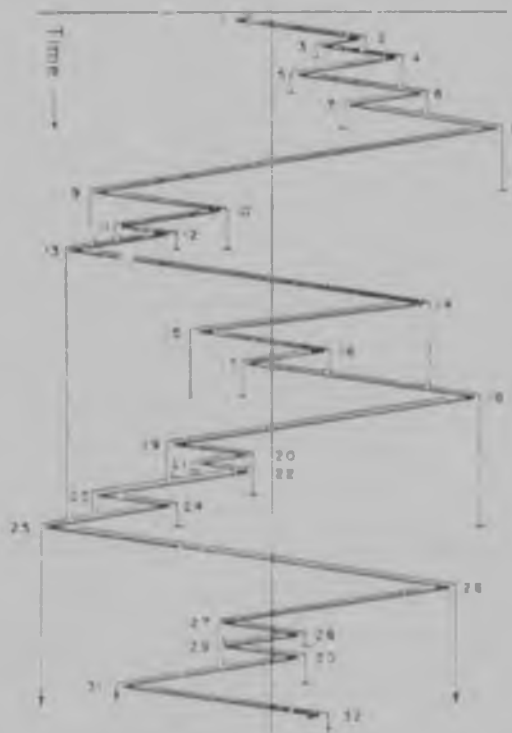

FIGURE 3.3 : Example of rainfall cycle-counting method

Rainflow begins successively at the inside of each peak and is allowed to drip down the roofs subject to the following rules:

- a) The rainflow initiating at each peak is allowed to drip down and continue except that if it initiates at a minimum it must stop when it comes opposite a minimum peak which is lesser in value than the peak from which it initiated. For example in Figure 3.3 rainflow initiating at peak 1 stops when it comes opposite peak 9 (peak 9 being the minimum peak with a value less than peak 1). If rainflow initiates at a maximum peak it must stop when it comes opposite a peak which has a greater value than the peak from which rainflow initiated.

In Figure 3.3 rainflow initiating at peak 14 stops when it comes opposite peak 18.

- b) Rainflow also stops if it meets the rain from the roof above. For example in Figure 3.3 rainflow initiating at peak 3 stops beneath peak 2.

When the procedure is applied to the whole record a half cycle is counted between the greatest maximum and the least minimum in the record. Additional half cycles are defined as follows: If the greatest maximum occurs first in the record additional half cycles are counted between this maximum and the least minimum before it in the record, between this minimum and the greatest maximum previous to it in the load history and so on to the beginning of the record. After the least minimum half cycles are counted which terminate at the greatest maximum occurring subsequently in the history, the least minimum occurring after this maximum and so on to the end of the record. If the least minimum occurs first in the record the procedure is reversed.

All the other ranges are counted as interruptions of these half cycles, or as interruptions of the interruptions, etc., and will always occur in pairs of equal magnitude to form full cycles.

Referring to Figure 3.3 half cycles and cycles are counted as follows:

	<u>Half cycles</u>	<u>Cycles</u>
Peak	8-25	Peak 2-3
	8-1	4-5
	25-26	6-7
	26-31	9-10
	31-32	11-12
		13-18
		14-15
		16-17
		19-20
		21-22
		23-24
		27-28
		29-30

The method corresponds to the cyclic stress strain response of the material in that all ranges counted as cycles will form closed stress-strain hysteresis loops whereas half cycles will not.

### 3.6 The Reservoir method<sup>12</sup> of cycle counting

This method is given in BS 5400 and is intended for short records only, such as the record caused by the passage of a vehicle over a bridge. It considers the record as the cross section of an imaginary reservoir which is filled up to the highest peak in the record. Starting from the lowest point the reservoir is then drained from each low point successively, counting one cycle for each draining operation, with the corresponding range being the height of the water column drained each time. The method is illustrated in Figure 3.4.

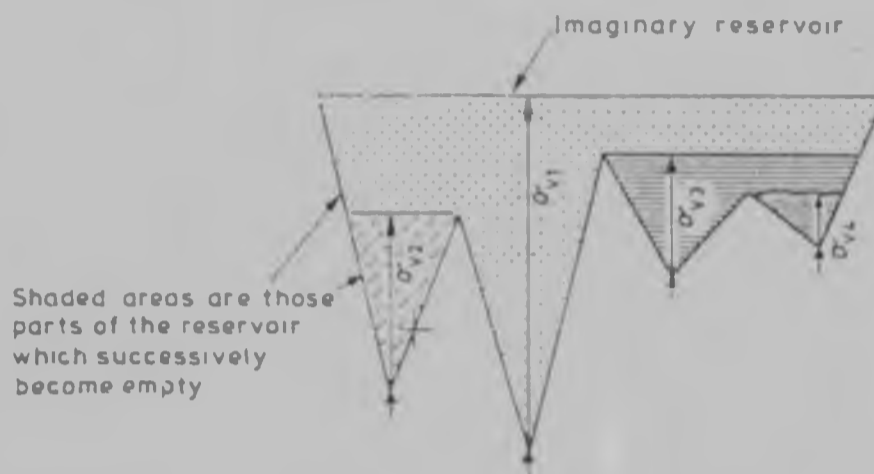

FIGURE 3.4 : Example of the reservoir method of cycle-counting

### 3.7 Discussion of cycle-counting methods

It is instructive to compare the various cycle counting methods on the basis of the results obtained by applying each one to a short record. The record is shown in Figure 3.5 and the results obtained are tabulated in Table 3.2.

It must be pointed out here that the greatest flaws of some of these methods are highlighted by particular properties of the dynamic record in each case and it is not possible to include for all these defects in the short record of Figure 3.5. However for the Range-pair and the Rainflow methods no record can be devised where unreasonable results are obtained.

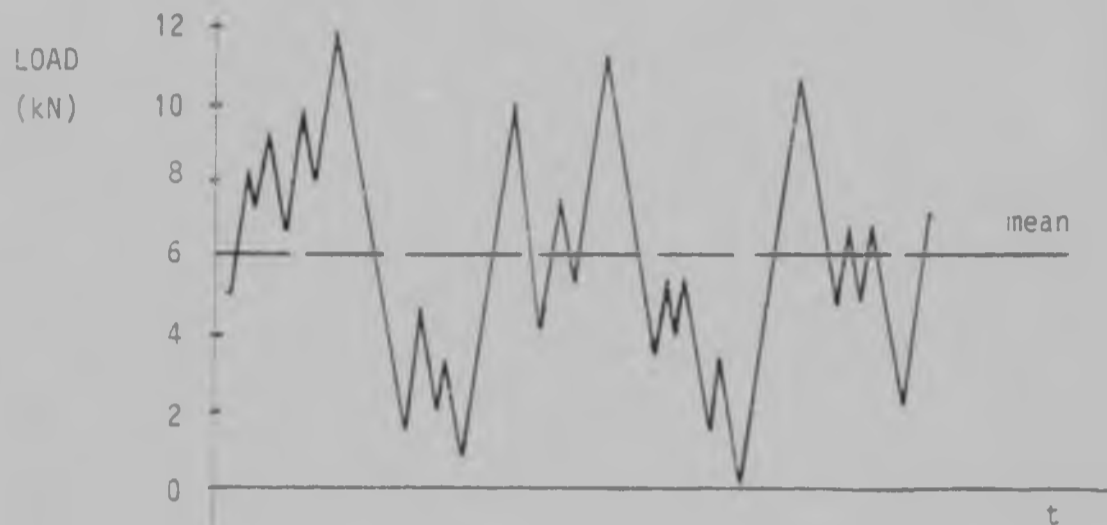

FIGURE 3.5 : Record used for comparing the various counting methods

In Table 3.2 most of the methods do not allow for the counting of half cycles. However these were included, to make comparisons compatible, on the basis that if the record was repeated the half cycles would then combine to form full cycles.

The last row of Table 3.2 expresses the equivalent cycles at a range of 2 kN which would cause the same fatigue damage (if all the ranges were damaging) as would be caused, by the application of the ranges in each column, for welded details of Class D-W (as defined in ref. 13). The method for deriving this is described in Chapter 4.

TABLE 3.2 CYCLES COUNTED BY EACH COUNTING METHOD FOR THE RECORD IN FIGURE 3.5

LOAD RANGE (kN)	C Y C L E S									
	PEAK	MEAN CROSSING PEAK	LEVEL CROSSING	FATIGUE METER	RANGE	RANGE MEAN	RANGE PAIR	RAINFLOW	RESERVOIR	
1,0	1	1	1	0	2	2	3	3	3	
2,0	3	3	1	1	5	5	7	7	7	
3,0	1	1	1	0	3	3	1	1	1	
4,0	1	1	1	0	1	1	0	0	0	
5,0	1	0	0	0	1	1	1	1	0	
6,0	1	0	1	1	1	1	1	1	1	
7,0	0	0	1	1	0	0	1	1	0	
8,0	2	1	1	1	1	1	0	0	0	
9,0	1	1	1	1	1	1	1	1	1	
10,0	1	1	1	1	1	1	1	1	1	
11,0	0	0	1	1	1	1	1	1	0	
12,0	1	1	0	1	0	0	1	1	1	
Equip @ 2 kN	3137,7	2395,6	2613,3	3490,2	1299,9	1299,9	2123,4	2123,4	2424,3	

NOTE: For the fatiguemeter method a count is only made when the load crosses a level of 2 kN lower (or higher) in the opposite direction

An examination of Table 3.2 shows up the differences between the various counting methods. Assuming that the best results are obtained from the Rainflow method it is clear that while the Range and Range Mean methods yield results that are not conservative (because the large ranges are broken down and counted as a series of smaller ones), the Peak and Fatiguemeter methods yield results which are unduly conservative. In the case of the Peak method it is obvious that the underlying principle that all peaks are variations about the mean is unreasonable in this case. The Fatiguemeter method is sensitive to the preset load level specified, which the load must cross in the opposite direction, before a count is made, and while in this case this and the level crossing method give conservative results there are situations where the results are not conservative<sup>11</sup>. The mean crossing peak method is unreliable in most situations. The Reservoir method yields reasonable results on the conservative side.

The factors relating to the fatigue loading spectrum which affect fatigue behaviour appear to be the following:

- a) Load Range - As the high load ranges are in most cases responsible for fatigue crack initiation and subsequent damage it is important that they are counted accurately with due account being taken of the effect of the minor load reversals superimposed on the large load ranges.
- b) The sequence in which load ranges occur. The reason for this is that there are two stages in the fatigue life of a material. The first stage involves initiation of the fatigue crack with the second

stage constituting the fatigue life taken for the crack to grow and reach critical proportions. Clearly high load ranges which occur before crack initiation have a different effect to the same ranges occurring after the crack has initiated. In addition load ranges which are below the fatigue limit of the material start to cause damage when the fatigue crack reaches certain proportions. Sequence effects are important in situations such as fatigue testing where a large number of cycles of a low range are first applied, followed by the application of high range cycles, or vice versa, until failure occurs. However as far as this project is concerned the ranges occur in an approximately random manner and ignoring sequence effects will not have a pronounced effect on the results.

- c) Position of the load range with respect to mean load - In records where large mean loads are present the fatigue life cannot be adequately predicted without considering the effect of the mean load. Tensile mean loads shorten the fatigue life while compressive mean loads prolong it. This is a difficult factor to allow for particularly in complicated records and it is not taken into account in most design codes.

In most of the cycle-counting methods discussed previously not one of the above three factors is monitored accurately with the result that fatigue life predictions become rather unreliable. Where fatigue loading is the result of a number of short records applied repeatedly it is possible to examine the records manually and make allowance for the above factors but where long records are involved this task becomes extremely laborious.

### Computer program for cycle counting

The foregoing discussion showed that fatigue life predictions are rather tentative but as far as this research project was concerned a computer programme was required to obtain the fatigue loading spectrum from the records of wheel load measurement which were too long to handle manually. This programme could have taken a general form in order to cater for all cases of fatigue loading but the degree of complexity required in order to achieve this was not justified at this stage. Therefore, it was decided to produce a programme, with the specific purpose of analysing the results of the research project, both theoretical and experimental, which would operate with a reasonable degree of accuracy.

The type of load records that this programme would be required to analyse are shown in Figures 3.6 and 3.7 which were obtained from Krige's work. (Note that the horizontal scales in Figures 3.6 and 3.7 are different).

It is likely that if the results of this research project are satisfactory, and the computer programme is adequate it will be used for parametric studies in conjunction with DISCS which predicts load records that can be roughly considered as a combination of a high frequency-low amplitude and a low frequency-high amplitude waveforms as shown in Figure 3.6.

A most suitable method of deriving the fatigue loading spectrum from a load record of this nature is a modified form of the Reservoir method where the load record is considered as broken down into sections.

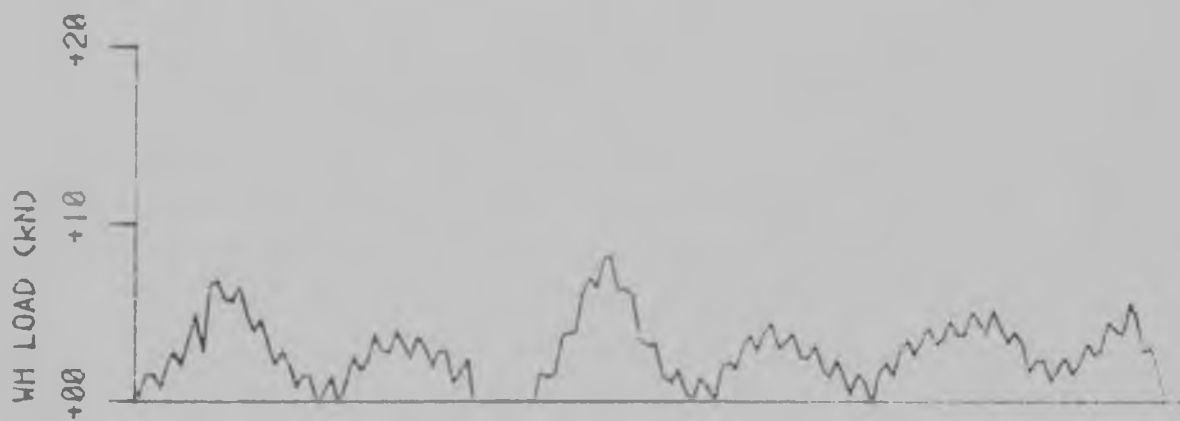

FIGURE 3.6 : Typical load record predicted by the theoretical DISCS model

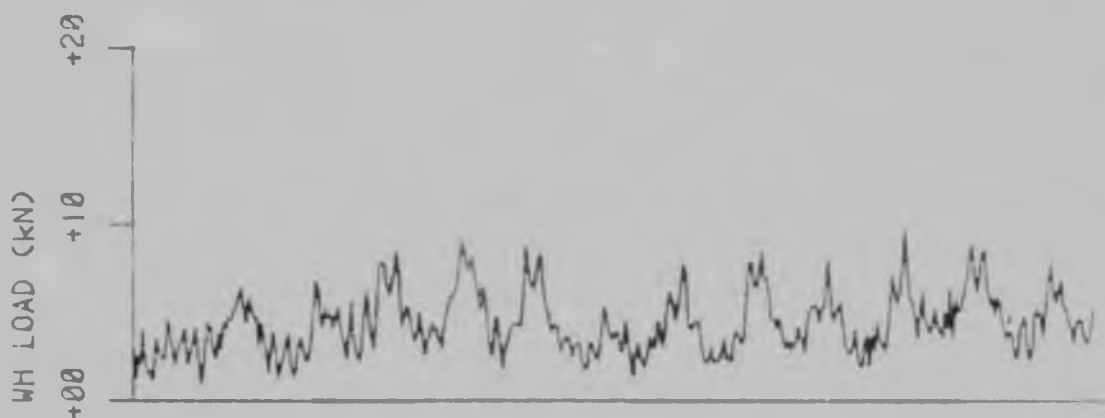

FIGURE 3.7 : Load record from the experimental measurement.

Each section corresponds to one cycle of the low frequency-high amplitude part of the curve, from peak to peak and this section can then be considered as the cross-section of a reservoir filled with water up to the level of the first peak. By draining the reservoir successively from each low point and repeating the procedure for all sections of the load record the fatigue loading spectrum can be obtained.

Most of the load records obtained experimentally exhibited the feature that they were punctuated with high peaks at regular intervals. These high peaks made it possible for the load record to be broken down into sections between high peaks which sections could be considered as a series of reservoirs which could be used to derive the fatigue loading spectrum.

As it was felt that this method of breaking down a load record could yield a reasonable estimate of the fatigue loading spectrum and at the same time be reasonably easy to incorporate into a computer programme it was decided to produce a computer programme for deriving the fatigue loading spectrum from a load record based on this method.

For an accurate assessment of the fatigue loading spectrum either the Range Pair or the Rainflow cycle-counting method would have to be used, both of which consider the whole record at the same time and are very complex even when applied manually to relatively short records.

The length of the records involved in this project prohibited any thought of using any of these two methods in the computer programme.

### 3.9 Description of computer programme for cycle-counting

A definition of certain terms used here is necessary before proceeding with this discussion:

peak - any maximum identified on the record

high peak - a peak which has a higher value than the previous and following peaks

low peak - a peak which has a lower value than the previous and following peaks

trough - any minimum identified on the record.

As mentioned previously the programme breaks up the record into sections between high peaks and operates on these sections in a manner analogous to the Reservoir method of cycle-counting. With reference to Figure 3.8 which is an expanded view of part of the record in Figure 3.6 the programme operates as follows.

By considering three consecutive values from the load record it checks for locations of slope reversal thus identifying the peaks and troughs in the record as it proceeds through it. In Figure 3.8 peaks identified would be 1, 2, 3, 4 etc and troughs 1', 2', 3', 4' etc.

In addition as the programme proceeds it retains the values of the three most recent peaks and checks for slope reversal amongst these, thus identifying high and low peaks. In Figure 3.8 high peaks are 2, 9 and 18 while low peaks are 6, 13 and 21.

A cycle is counted every time a peak is identified and the range corresponding to this cycle is calculated as follows:

- a) If the peak identified is in a region between a high peak and a low peak, the range is the difference between the identified peak and the previous trough. For example in Figure 3.8 when peak 4 is identified a cycle is counted with the range being the difference in values between peak 4 and trough 3'.



FIGURE 3.8 : Part of Load record

- b) If the peak identified is a low peak the range is the difference between the value of the high peak previously identified and the lesser value of the two troughs adjacent to this low peak. In Figure 3.8 when peak 6 is identified as a low peak the range is the difference between peak 2 and trough 5'.
- c) If the peak identified is in a region between a low peak and a high peak the range corresponding to the cycle counted will be the difference between the preceding trough and the peak previous to it. In Figure 3.8 when peak 8 is identified the range corresponding to the cycle counted is the difference between peak 7 and trough 7'.

The procedure is analogous to the Reservoir method of cycle counting in that if the section of the record between two consecutive high peaks is considered as the cross section of a reservoir with the top of the water at the level of the first high peak the ranges and cycles for that section of the record will be identical to those obtained when using the Reservoir method.

Repeating this for all sections of the record between high peaks will yield the loading spectrum for the whole record.

### 3.10 Comments on efficiency of computer programme

Because of the very nature of the programme, which considers the record as a number of sections between high peaks, it will be ideally suited to records which can be considered to consist of a low-frequency high amplitude waveform with a high-frequency low amplitude waveform superimposed on it as shown in Figure 3.9. The sections of the record between high peaks which can also be considered as imaginary reservoirs are indicated.

The major weakness of the programme is that it only considers three consecutive peaks when trying to identify positions of high peaks and thus minor reversals in peak values result in only a small section of the record being considered each time thus breaking up large ranges into smaller ones. This effect is illustrated in Figure 3.10 where peak C would be identified as a high peak causing the section of the record between peak A and peak E to be considered as two sections (A-C) and C-E) thus not counting the large range between peak A and trough D.

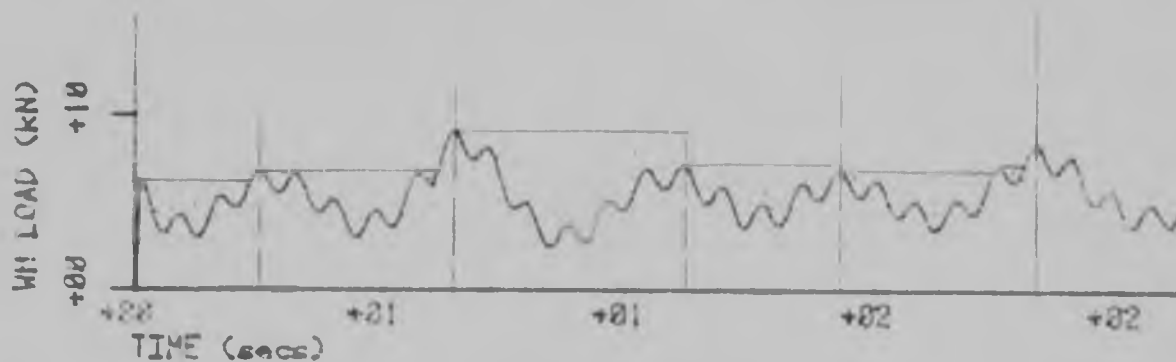

FIGURE 3.9 : Load record, ideally suited for analysis by the computer programme



FIGURE 3.10 : Load record which highlights weakness in programme

Another flaw of the computer programme is that it only monitors the values of the peaks and it is thus assumed that the lowest trough occurs adjacent to the low peak. This is not always the case as is illustrated in Figure 3.12 and as a result certain ranges tend to be underestimated.

### 3.11 Applicability of computer programme to general records

Two load records are used here in order to demonstrate the applicability of the computer programme to general records. Firstly the programme is applied to the record, which was used for comparing the various cycle-counting methods, and is shown in Figure 3.11. The sections of the record between high peaks and the ranges are indicated on the record.

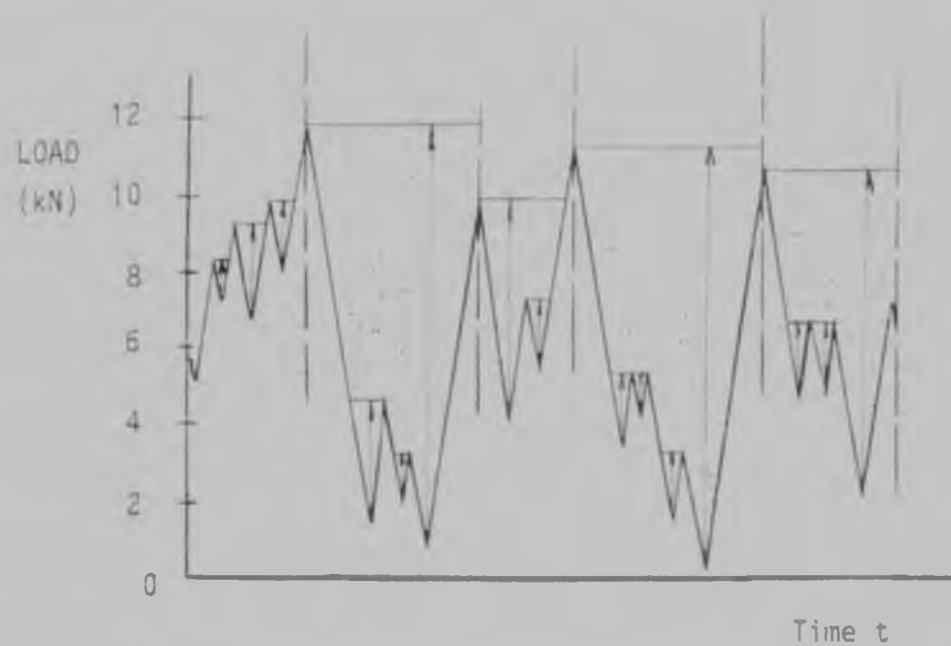

FIGURE 3.11 : Record used for comparing computer programme results to the cycle counting methods

The results obtained are tabulated in Table 3.3 and it can be seen that they compare favourably with the results obtained from the Range-pair and Rainflow methods which have been repeated in this table.

The second record, shown in Figure 3.12, was especially devised in order to demonstrate applicability of the method, used in the computer programme, under the most unfavourable conditions. Again the record is broken into sections between high peaks as identified by the programme and the ranges are drawn in.

TABLE 3.3 : CYCLES COUNTED BY COMPUTER PROGRAMME AND RANGE-PAIR AND RAINFLOW METHODS FOR THE RECORD IN FIGURE 3.11

RANGE (kN)	1	2	3	4	5	6	7	8	9	10	11	12	EQUIV. @ 2 kN
COMPUTER PROGRAMME	3	7	1	0	0	1	0	0	1	0	2	0	2333,4
RANGE PAIR & RAINFLOW METHODS	3	7	1	0	1	1	0	1	1	1	1	1	2123,4



FIGURE 3.12 : Record for which unfavourable results are obtained when using computer programme

In this record firstly the large range between peak 1 and trough 2 is broken down into a series of smaller ranges and secondly the range between peak 3 and trough 4 is not counted. Obviously the programme is unsuitable for this type of record but it would need an extremely complex programme to pick up the ranges in Figure 3.12.

TABLE 3.3 : CYCLES COUNTED BY COMPUTER PROGRAMME AND RANGE-PAIR AND RAINFLOW METHODS FOR THE RECORD IN FIGURE 3.11

RANGE (kN)	1	2	3	4	5	6	7	8	9	10	11	12	EQUIV. @ 2 kN
COMPUTER PROGRAMME	3	7	1	0	0	1	0	0	1	0	2	0	2333,4
RANGE PAIR & RAINFLOW METHODS	3	7	1	0	1	1	0	1	1	1	1	1	2123,4



FIGURE 3.10 : Record for which unfavourable results are obtained when using computer programme

In this record firstly the large range between peak 1 and trough 2 is broken down into a series of smaller ranges and secondly the range between peak 3 and trough 4 is not counted. Obviously the programme is unsuitable for this type of record but it would need an extremely complex programme to pick up the ranges in Figure 3.12.

A visual inspection of most of the records predicted by DISCS as well as the ones obtained experimentally showed that in the majority of cases the programme would give reasonable results as records of the type shown in Figure 3.12 occurred very seldom.

3.12 FAG - Computer programme for derivation of the fatigue loading spectrum from a load record

The computer programme developed was called FAG and the flow chart for it is shown in Figure 3.13. A listing of the programme is given in Appendix A while Figure 3.14 shows the typical output obtained when using FAG.

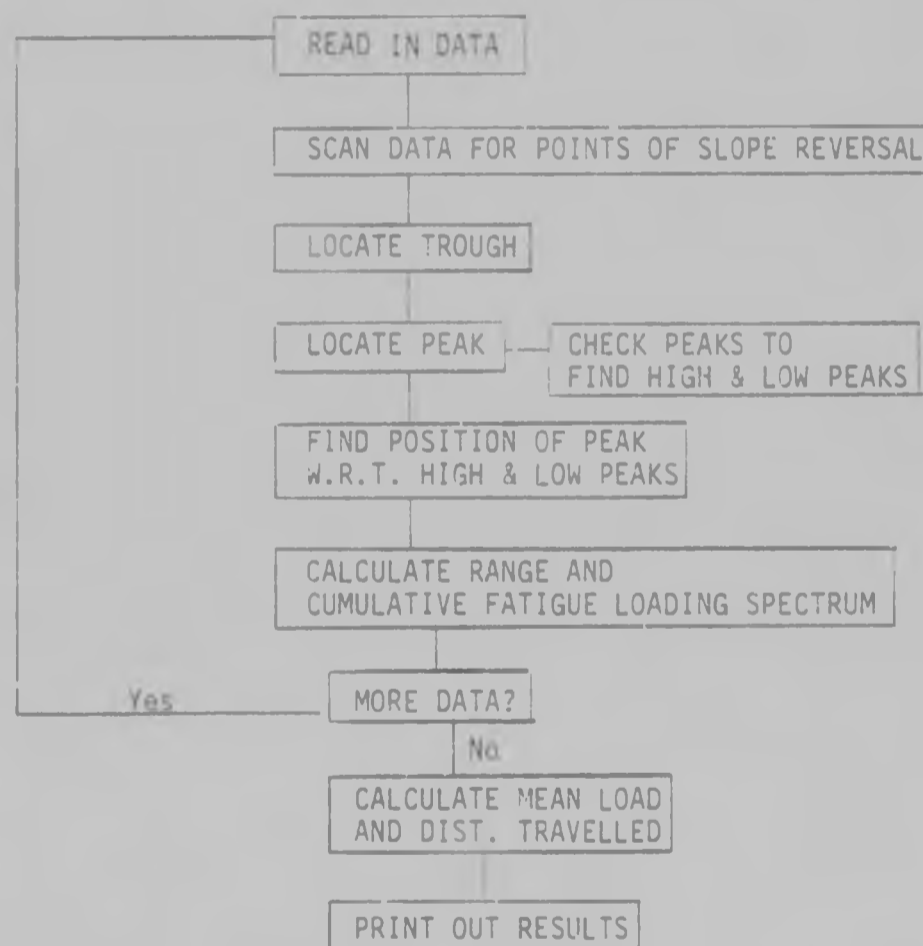

FIGURE 3.13 : Flow chart for FAG

HAARTIES 64 DOWN EMPTY 15M/S

## FATIGUE LOAD SPECTRUM

LOAD RANGE (KN) *****	NO. OF CYCLES *****		
	WHEEL 1 *****	WHEEL 2 *****	WHEEL 3 *****
1.0	524	79	236
2.0	568	489	242
3.0	401	401	177
4.0	221	320	227
5.0	112	286	166
6.0	50	175	83
7.0	31	120	73
8.0	11	69	52
9.0	4	33	33
10.0	3	28	19
11.0	1	13	9
12.0	1	6	5
13.0	0	1	1
14.0	0	1	1
15.0	0	1	1
16.0	0	1	1
17.0	0	1	1

MEAN LOAD (KN) = 1.33 5.13 1.63

LENGTH OF SHAFT CONSIDERED = 1500.)

FIGURE 3.14 Typical output from FAS

REPORT : FATIGUE ANALYSIS OF THE EXPERIMENTAL  
MEASUREMENTS.

4.1 INTRODUCTION

Once the computer programme FAG was developed it was possible to obtain the fatigue loading spectra from the various records of the experimental wheel loads available. Unfortunately, even though the measurement programme was quite successful wheel load records were not obtained from all the shafts tested, for reasons described in Chapter 2, and this will limit somewhat the confidence in the fatigue analysis. This becomes more apparent when examination of the results obtained shows that results from different mineshafts are difficult to correlate.

Obviously the dynamic behaviour of shaft steelwork depends on many variables which are not the same in different shafts, and this is reflected in the results, making comparisons difficult and to a fairly large extent non-compatible. However it was felt that much useful information could be gained by grouping all the results together and thereafter drawing possible conclusions. This thought was based on the fact that presently at the design stage most of these variables are not considered anyway.

The fatigue loading spectra obtained from FAG were in the form shown in Figure 3.14, and after all the records were analysed a large amount of data became available which were very cumbersome to handle in that form. It was clear that the results had to be reduced to a more suitable form to make comparisons easier.

An additional problem was that results from various speeds of conveyance were obtained. In order to make the results from different speeds compatible for comparisons they had to be considered either in terms of the time the conveyance was under operation or, in terms of the number of buntons passed by the conveyance. It was felt that the second method would be more relevant and in the end the results were reduced to bunton space.

Having decided on this, it appeared from the earliest results analysed that all the runs in a shaft could be combined and represented by a mean and a standard deviation for each load range. This was attempted but it was soon apparent that for the high ranges which are important the coefficient of variation was very high making this method unsuitable. In addition when all the data from the different shafts were reduced in this manner there was still a fair amount of data to handle.

A more suitable method of comparing the data, would be a method whereby, the loading spectrum derived from one test run could be represented in terms of one load range, applied an equivalent number of times, to cause the same fatigue damage as would be caused by applying the individual load ranges in the fatigue loading spectrum.

#### 4.2 Derivation of a method whereby different ranges in the fatigue loading spectrum can be represented by a specified range applied an equivalent number of times.

This discussion is based on Ref. 14 with the assumption that all ranges are damaging.

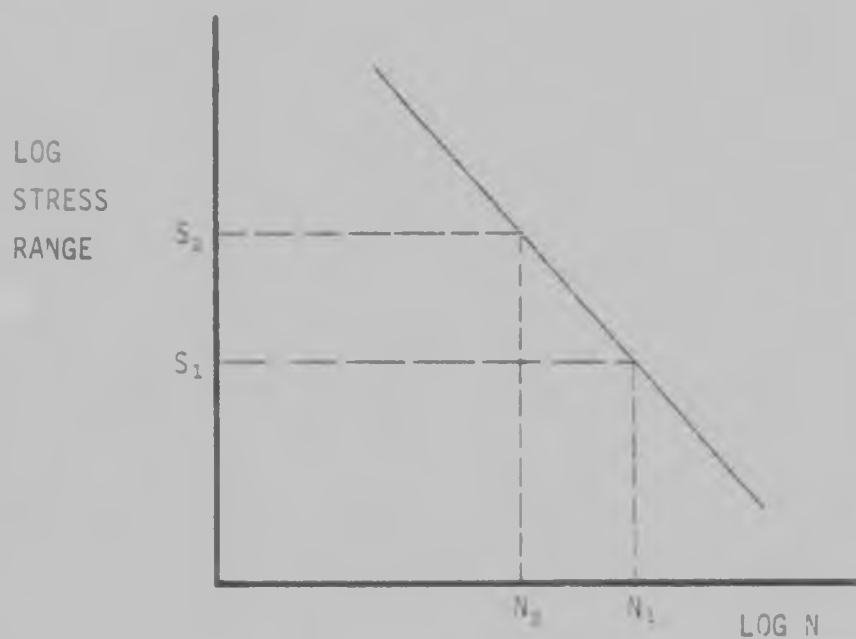

FIGURE 4.1 : Typical S-N curve

A typical S-N curve used for fatigue damage calculations is shown in Figure 4.1. The equation of the curve for all classes of welded joints can also be written as

$$\text{Log } N = \text{Log } a + m \text{ Log } S \dots\dots\dots (1)$$

where  $\text{Log } a$  = theoretical intercept on horizontal axis  
 $m$  = slope of S-N curve  
 $S$  = stress range

From equation (1)

$$\begin{aligned} \text{Log } N_1 &= \text{Log } a + m \text{ Log } S_1 \\ \text{and } \text{Log } N_2 &= \text{Log } a + m \text{ Log } S_2 \end{aligned}$$

Subtracting:  $\text{Log } N_1 - \text{Log } N_2 = m (\text{Log } S_1 - \text{Log } S_2)$

$$\text{i.e. } \text{Log } \frac{N_1}{N_2} = m \text{Log } \frac{S_1}{S_2}$$

$$\text{i.e. } \frac{N_1}{N_2} = \left(\frac{S_1}{S_2}\right)^m \dots\dots\dots (2)$$

Now if  $n_1$  = Number of cycles applied at stress level  $S_1$

and  $n_2$  = number of cycles applied at stress level  $S_2$

Using Miner's Rule:

For the same fatigue damage  $D$  to be caused by  $N_1$  and  $N_2$

$$\frac{n_1}{N_1} = D = \frac{n_2}{N_2}$$

$$\text{i.e. } \frac{n_1}{N_1} = \frac{n_2}{N_2}$$

$$\text{and } \frac{N_1}{N_2} = \frac{n_1}{n_2} \dots\dots\dots (3)$$

substituting equation (3) into equation (2)

$$\frac{n_1}{n_2} = \left(\frac{S_1}{S_2}\right)^m$$

$$\text{and } n_1 = n_2 \left(\frac{S_1}{S_2}\right)^m \dots\dots\dots (4)$$

Therefore using equation (4)  $n_2$  the number of cycles applied at stress level  $S_2$  can be converted to an equivalent number of cycles  $n_1$  applied at stress level  $S_1$  which would cause the same fatigue damage for the same class of welded joint.

Two points are worth mentioning here. Firstly when the fatigue loading spectrum is converted in this manner information about ranges that are not damaging is lost but the error involved in doing this is small and on the safe side anyway. However as far as the computer programme is concerned such a minimum cut-off stress level could be specified and ranges below this level neglected.

It follows that when converting to an equivalent range this range should be chosen so as to cause stresses above the cut-off limit.

The second point is that the S-N curves for the commonly used welded joints (Classes D, E, F, F, G and W)<sup>13</sup> are parallel with a slope of -3 and fatigue damage calculations for a certain class of joint can be converted to another class of joint on a simple pro-rata basis<sup>14</sup>. However for joint Class B (slope of S-N curve = -4) and joint Class C (slope of S-N curve = -3,5) this cannot be done.

#### 4.3 Analysis of the experimental measurements

The analysis was carried out using FAG and afterwards the fatigue loading spectra were reduced to an equivalent load range of 5 kN using equation (4). The slope of the S-N curve used was -3 which applies to the commonly used welded joint details. The results are tabulated in Table 4.2 while in Table 4.1 details of the shafts where measurements were taken are given.

TABLE 4.1 : DETAILS OF SHAFTS WHERE RECORDS OF WHEEL LOAD MEASUREMENTS WERE OBTAINED

MINESHAFT	WESTERN HOLDINGS 1# SKIP	HARTIES 6# 105 MEN CAGE	HARTIES 8# 105 MEN CAGE	HARTIES 8# 5t SKIP	PRES. STEYN 4# 10t SKIP	DEELRAAL 1# 20t SKIP	F.S.G.* 5# 14t SKIP
SHAFT LAYOUT							
WHEEL LOAD MEASURED							
MASS OF EMPTY CONVEYANCE	± 7,0t	5,9t	5,9t	4,5t	6,6t	13,5t	9,1t
MASS OF FULL CONVEYANCE	17,6t	13,25t	13,25t	9,5t	16,6t	29,5t	23,1t
BUNTON SPACING	3,8m	4,5m	4,5m	4,5m	6,1m	4,0m	4,5m
GUIDE WHEEL SPACING	± 6,3m	6,7m	6,7m	6,5m	7,5m	10,6m	9,5m
TYPE OF GUIDE WHEEL	SKF	PATENT PRODUCTS	PATENT PRODUCTS	PATENT PRODUCTS	PATENT PRODUCTS	PATENT PROD. BOTTOM	PATENT PRODUCTS

\*FREE STATE GEDULD

TABLE 4.2 : FATIGUE LOADING SPECTRA OBTAINED FROM THE EXPERIMENTAL RECORDS OF WHEEL LOAD EXPRESSED IN THE FORM OF THE EQUIVALENT NUMBER OF APPLICATIONS OF A 5kN LOAD RANGE

MINE SHAFT	W. HOLDINGS 1# SKIP		HARTEBEEFSFONTEIN 5# 105 MEN CAGE				HARTEBEEFSFONTEIN 8# 105 MEN CAGE		HART. 8# 5t SKIP		PRES. STEYN 4# 10t SKIP			DEELKRAAL 1# 20t SKIP		TSG 5# 14t SKIP	
	100 SECS	100 SECS	1	3	4	2	3	4	3	4	2	3	4	60 SECS	60 SECS	60 SECS	60 SECS
LENGTH OF RECORD	0,60	0,42	3,50	5,20	3,14	2,15	5,19	3,72	3,90	7,50	3,80	5,04	4,20	3,00	5,30	5,35	
WHEEL NUMBER	13	57	619	3044	1226	54	108	67	325	1558	806	1763	2209	321*	837*	1095	
AVERAGE PRELOAD (kN)			639	2835	963	54	109	71		1135	2532	3042	45	65	1052		
UP FULL 17,8 m/s			2685	14844	201*	64	153	96	234	1843				170	147	3160	
UP FULL 15 m/s			636	2552	775									147	178		
"			559	2382	484												
"			539	2324	470												
DOWN EMPTY 15 m/s	10	39	679	2454	1675	60	142	80	207	2116				40	119	2578	
"			560	2603	792	60	121	77	199	2204				31	110	3207	
"			565	2792	784	60	108	74						24	65		
"			567	2490	656									45	293		
"			498	2163	548									41	1726		

\*See discussion of the results

TEST CONDITION

TABLE 4.2 continued

MINESHAFI	WHEEL NO.	W. HOLDINGS 14 SKIP	HARTIES 6 # 105 MEN CAGE	HARTIES 8 # 105 MEN CAGE	HARTIES 8 # SKIP	PRES. STEYN 4 # 10t SKIP			DEELKRAAL 20t SKIP		M FSG 5 #
						2	3	4	2	4	
	DOWN FULL 15 m/s					837	1812	2162			1259
	"					884	1866	2166			1333
	UP FULL 12,5 m/s								20	38	
	DOWN EMPTY 12,5 m/s								15	35	
	UP FULL 10 m/s					186	399	604	22	25	892
	"					141	257	440	51	22	772
	UP EMPTY 10 m/s								61	46	848
	"										898
	DOWN FULL 10 m/s					153	281	487			1160
	"					114	198	315			1117

TEST CONDITION

TABLE 4.2 continued

MINESHAF	WHEEL NUMBER	W. HOLDING 1# SKIP				HARTIES 6 # 105 MFN CAGE				HARTIES 8 # 105 MEN CAGE				HARTIES 8# SKIP		PRES. STEYN 4# 10t SKIP			DEELRAAL 1 20t SKIP		FSG 5#				
		1	4	3	4	2	3	4	3	4	2	3	4	2	3	4	2	4							
	DOWN EMPTY 10 m/s																								
	"																								
	UP FULL 7,5 m/s	9	41																						
	UP EMPTY 7,5 m/s																								
	DOWN EMPTY 7,5 m/s																								
	UP FULL 5 m/s																								
	"																								
	UP EMPTY 5 m/s																								
	DOWN FULL 5 m/s																								
	"																								
	DOWN EMPTY 5 m/s																								

TEST CONDITION

#### 4.4 Discussion of the results

Before proceeding with this discussion certain points relating to each mineshaft should be noted.

Western Holdings Number 1 Shaft Skip was the only skip with an aluminium bridle tested. In this shaft joists are used as buntons about their weak axis making them very flexible. It is considered to be a good shaft by staff at the mine with no vibration problems.

Hartebeesfontein Number 6 Shaft and Number 8 Shaft cages are similar in detail, but the shaft steelwork connections are different, with much poorer tolerances in Number 6 shaft. In addition in Number 6 shaft the rubber lining on the wheels broke during the first up run which explains the high ranges obtained from that run. After this run three of the wheels were replaced but wheel 3 was not replaced remaining in a bad condition, which perhaps explains the consistently high load ranges obtained from this wheel.

The Hartebeesfontein Number 8 shaft skip is against a very stiff bunt on the one side as is shown on Table 4.1.

President Steyn Number 4 shaft skip is between very stiff buntons and in addition Krige' feels that there was resonance between the frequency of revolution of the wheel and the natural frequency of vibration of the wheel about its pivot.

Deelkraal Number 1 shaft skip is against the shaft wall on the one side, but after serious vibration problems experienced initially, the shaft steelwork has been repaired and realigned to the extent that it can now be

considered a good shaft. However in two of the runs which are denoted by an asterisk in Table 4.2 a very bad bump was observed in the records which was responsible for the high fatigue loading obtained. It was not possible to establish whether this bad bump occurred at the same location in the shaft. The much higher fatigue loading on wheel 4 of this skip during one of the down empty runs at 15 m/s, is the result of consistently high vibration in this run. It is probable that resonance is the cause of this.

The skip in Free State Geduld Number 5 shaft is also between very stiff buntons but in this skip only an out of plane wheel load was obtained.

A critical examination of the results shows that while it is very difficult to correlate the results from different mineshafts, even in the case of similar shafts several important trends can be identified. These are the following:

- a) Behaviour within each mineshaft is consistent. This is observed in all shafts and it is important because it indicates that behaviour depends on a set of variables which are unique in each shaft.
- b) Conveyance speed - In all cases where measurements at different hoisting speeds were obtained there is a definite trend towards less severe fatigue loading as the speed decreases. The relationship is not linear but of exponential form. The only exception to this trend is the Deelkraal Number 1 shaft skip where the 10 m/s runs cause higher fatigue loading than the 12,5 m/s runs. However Krige<sup>3</sup> suggests that there is a limited amount of resonance at 10 m/s which would explain this anomaly.

- c) Conveyance mass - This does not appear to affect fatigue loading as there is no noticeable difference in the fatigue loading spectra for empty and loaded conveyance runs in each shaft. It would be expected that because of better damping characteristics the loaded conveyance would have a beneficial effect on the fatigue loading spectrum. It is possible that increased damping is present but is offset by larger forces on the wheels.
- d) Up and down trips - There is no noticeable difference in behaviour between up and down trips and this corresponds to the assumption by Krige<sup>3</sup> that all vertical weight and motion can be neglected.
- e) Bunton stiffness - It is quite clear that higher bunton stiffnesses result in higher fatigue loading spectra. This is evident in all the shafts where the wheel on the side of the stiffer bunton is subject to higher fatigue loading. It appears also that for conveyances between buntions of different stiffnesses wheel loads on the one side are affected by the bunton stiffness on the opposite side, and it is likely that fatigue loading depends on the sum of the bunton stiffnesses on each side of the conveyance. The only anomaly here is the Deelkraal Number 1 shaft skip but as discussed earlier remedial measures have been taken here after the initial severe vibration problems.
- f) Ratio of bunton spacing to guide wheel spacing - There is no consistent pattern to suggest that this ratio has an effect on the fatigue loading but Loubser and Bull<sup>5</sup> have recommended that situations where the guide wheel spacing is approximately twice the bunton spacing should be avoided. This situation

... in the Free State Geduld Number 5 shaft where fatigue loading is quite high but it is difficult to tell whether this aspect alone is responsible for the high fatigue loading.

A factor which could possibly affect the fatigue loading is the ratio of the conveyance mass to the guide wheel spacing. There is evidence in the results to suggest that as this ratio decreases fatigue loading increases but whether this is due to this factor it is difficult to tell.

Preload - It appears here that a higher preload is associated with higher fatigue loading but it must be mentioned here that the preload was obtained by averaging out the records. Since the load cannot assume a negative value higher ranges in the fatigue loading spectrum will cause higher values of the average load to be obtained. If this was not the case then the preload on wheels on opposite sides of the conveyance should have been similar.

Top and bottom guide wheels - Fatigue loading on the bottom guide wheels is much higher than on the top wheels. This can be attributed to the fact that the bottom wheels are much closer to the centre of gravity of the conveyance than the top wheels. It has also been proposed that the hoisting cable causes additional damping on the top wheels.

Type of guide-roller assembly - Only one result is available from a conveyance with the SKF type guide-roller assemblies. Even though fatigue loading in this shaft is very much less than in other shafts where 'Patent Products' assemblies are used it would be unreasonable at this stage to draw any conclusions on the basis of one result only.

- k) Fatigue loading transverse to the plane of the buntons - On the basis of the result obtained from Free State Geduld Number 5 shaft it is clear that fatigue loading in this plane is quite significant and cannot be considered of a secondary nature.

#### 4.5 Statistical Analysis of the results

The object of this analysis was to derive from the results of Table 4.2 an equivalent range with a 5% probability of occurrence that is applied on average once per buntion passage, in each shaft.

Before any such analysis could be carried out it was necessary to find out if fatigue loading in a shaft was the result of constant excitation of the conveyance, or the result of a number of isolated bad vibrations which occurred at locations where the shaft steelwork was in poor condition. This could be done by considering short sections of shaft in detail and comparing behaviour over these short sections. For this purpose the records obtained from Doelkraal Number 1 shaft were broken up into 5 sec and 10 sec intervals and analysed. (A 5 sec interval corresponds to a length of shaft of 75 m at a hoisting speed of 15 m/s). The results are presented in Tables 4.3 and 4.4 in the form of a mean and a standard deviation of the number of applications of an equivalent 5 kN load range for the commonly used welded joints.

It is seen from these results that while for small sections of record quite high coefficients of variation are obtained indicating slightly irregular behaviour, over the longer 10 sec sections of record the coefficients of variation decrease indicating that the behaviour averages out.

It is reasonable to assume then that fatigue loading is the result of constant excitation of the conveyance and not of isolated bad vibrations. In any case regular shaft examinations ensure that sections of the shaft where the steelwork shows signs of deterioration are quickly remedied.

Of more importance is the analysis of the complete runs of the conveyance.

TABLE 4.3 DEELKRAAL NUMBER 1 SHAFT SKIP  
SOME STATISTICAL PROPERTIES OF THE FATIGUE  
LOADING (IN TERMS OF NUMBER OF APPLICATIONS  
OF A 5KN RANGE) FROM 12 CONSECUTIVE SECTIONS  
OF RECORD EACH 5 SEC LONG.

TEST CONDITION	WHEEL 2			WHEEL 4		
	MEAN	STANDARD DEVIATION	COEFF OF VARIATION	MEAN	STANDARD DEVIATION	COEFF OF VARIATION
UP 16,07t 15m/s	3,75	0,96	0,26	5,42	2,61	0,48
DOWN EMPTY 15m/s	3,33	2,60	0,78	3,92	5,12	0,52
"	2,58	1,34	0,52	9,17	4,84	0,53
"	2,00	1,04	0,52	5,42	2,35	0,43
"	3,75	2,09	0,56	24,42	21,53	0,88
UP 16,11t 12,5m/s	1,67	0,65	0,39	3,17	0,72	0,23
DOWN EMPTY 12,5m/s	1,25	0,45	0,36	2,92	1,00	0,34
UP 16,02t 10m/s	1,83	0,94	0,51	2,08	0,67	0,32
UP 16,9t 10m/s	4,25	7,02	1,65	1,83	0,58	0,32
DOWN FMPTY 10m/s	1,75	2,42	1,38	1,75	0,87	0,50

TABLE 4.4 : DEELKRAAL NUMBER 1 SHAFT SKIP

SOME STATISTICAL PROPERTIES OF THE FATIGUE  
LOADING (IN TERMS OF NUMBER OF APPLICATIONS  
OF A 5 kN RANGE) FROM 6 CONSECUTIVE SECTIONS  
OF RECORD EACH 10 SECS.LONG.

TEST CONDITION	WHEEL 2			WHEEL 4		
	MEAN	STANDARD DEVIATION	COEFF. OF VARIATION	MEAN	STANDARD DEVIATION	COEFF. OF VARIATION
UP 16,07t 15m/s	7,50	1,22	0,16	10,83	2,99	0,28
UP EMP. 15m/s	28,33	16,80	0,59	24,50	8,34	0,34
"	24,5	20,91	0,85	29,67	22,56	0,76
DOWN EMP. 15m/s	6,67	3,67	0,55	19,83	7,03	0,36
"	5,17	1,60	0,31	18,33	6,56	0,36
"	4,00	2,00	0,50	10,83	4,54	0,42
"	7,50	3,73	0,50	48,83	41,27	0,84
"	6,83	1,72	0,25	287,67	72,94	0,25
UP 16,11t 12,5m/s	3,33	0,82	0,25	6,33	1,03	0,16
DOWN EMP. 12,5m/s	2,50	0,55	0,22	5,83	1,33	0,23
UP 16,02t 10m/s	3,67	1,63	0,44	4,17	1,17	0,28
UP 16,9t 10m/s	8,50	9,31	1,10	3,67	0,82	0,22
UP EMP. 10m/s	10,17	6,49	0,64	7,67	3,01	0,39
DOWN EMP. 10m/s	3,50	3,39	0,97	3,50	1,38	0,39
"	9,50	7,66	0,81	8,00	1,10	0,14
"	8,67	2,73	0,32	7,17	2,71	0,38

TABLE 4.4 : DEELKRAAL NUMBER 1 SHAFT SKIP

SOME STATISTICAL PROPERTIES OF THE FATIGUE  
LOADING (IN TERMS OF NUMBER OF APPLICATIONS  
OF A 5 kN RANGE) FROM 6 CONSECUTIVE SECTIONS  
OF RECORD EACH 10 SECS. LONG.

TEST CONDITION	WHEEL 2			WHEEL 4		
	MEAN	STANDARD DEVIATION	COEFF. OF VARIATION	MEAN	STANDARD DEVIATION	COEFF. OF VARIATION
UP 16,07t 15m/s	7,50	1,22	0,16	10,83	2,99	0,28
UP EMP. 15m/s	28,33	16,80	0,59	24,50	8,34	0,34
"	24,5	20,91	0,85	29,67	22,56	0,76
DOWN EMP. 15m/s	6,67	3,67	0,55	19,83	7,03	0,36
"	5,17	1,60	0,31	18,33	6,56	0,36
"	4,00	2,00	0,50	10,83	4,54	0,42
"	7,50	3,73	0,50	48,83	41,27	0,84
"	6,83	1,72	0,25	287,67	72,94	0,25
UP 16,11t 12,5m/s	3,33	0,82	0,25	6,33	1,03	0,16
DOWN EMP. 12,5m/s	2,50	0,55	0,22	5,93	1,33	0,23
UP 16,02t 10m/s	3,67	1,63	0,44	4,17	1,17	0,28
UP 16,9t 10m/s	8,50	9,31	1,10	3,67	0,82	0,22
UP EMP. 10m/s	10,17	6,49	0,64	7,67	3,01	0,39
DOWN EMP. 10m/s	3,50	3,39	0,97	3,50	1,38	0,39
"	9,50	7,66	0,81	8,00	1,10	0,14
"	8,67	2,73	0,32	7,17	2,71	0,38

For the purpose of obtaining the 5% probability of exceedence limit of the fatigue load only shafts from which a reasonable number of runs were obtained were used. As there were no distinct differences between up and down trips of the conveyance, and fully loaded and empty runs these were grouped together for each value of hoisting speed. The analysis of the complete runs was based initially on the equivalent number of cycles of a 5 kN load range, for the commonly used welded joints, and finally the equivalent fatigue load range that can be expected to be applied on average once per buntong passed was obtained.

The Student T-distribution was used to obtain the 5% exceedence limit of the fatigue load from the mean and standard deviation. The number of standard deviations to be added to the mean are given in Table 4.5<sup>10</sup>.

TABLE 4.5 : CALCULATION OF 5% EXCEEDENCE LIMIT

NO. OF SAMPLES	1	2	3	4	5	6	7	8	9	10
No. of standard deviations to be added to mean to obtain 5% exceedence limit	-	2,916	2,273	2,062	1,957	1,894	1,852	1,822	1,800	1,783

The results of the analysis are tabulated in Table 4.6 for a conveyance speed of 15 m/s while in Table 4.7 results for conveyance speeds of 10 m/s and 5 m/s are presented. It must be pointed out here that for the

Hartebeesfontein Number 6 shaft cage the run during which the wheels were broken, and for the Deelkraal Number 1 shaft skip the two runs in which a single bad shock was identified were excluded from the analysis. This was done because the results from these runs differed vastly from the other results and they would have affected the standard deviations adversely.

#### 4.6 Comments on the statistical analysis of the results

The following important deductions can be made from the results:

- a) The equivalent fatigue load on the top wheels of the conveyance is on average less than on the bottom wheels by a factor of 1,4.
- b) On the basis of these results the effect of the conveyance speed on the fatigue load can best be represented by a linear relationship of the form  $\frac{V+10}{25}$  where V is the conveyance speed in m/s. This relationship is identical to the one found by Krige<sup>3</sup> relating the conveyance speed to the wheel load.
- c) There are two important aspects in the results which should be noted. The first is that while the cages in Hartebeesfontein Number 6 and Number 8 shafts are similar in detail and the shafts have similar layouts the steelwork in Number 8 shaft is in better condition because of installation procedures, as mentioned previously, resulting in a fatigue load that is about half that in Number 6 shaft.

The second aspect relates to the Hartebeesfontein

TABLE 4.6 : ANALYSIS OF 15 m/s TEST RUNS

MILNESHAF	HARTEBEEFSFONTEIN 6 # 105 MEN CAGE		HARTEBEEFSFONTEIN 8 # 105 MEN CAGE		HART. 6 # 5t SKIP		PRES. STILYN 4 # 10t SKIP		DEELKRAAL 1 # 20t SKIP		F. S. G. 5 #
	1	3	2	3	4	3	4	2	3	4	
WHEEL NO.	10	10	10	7	7	4	4	4	4	7	7
NO. OF SAMPLES	586	2564	837	59	124	78	241	1930	2395	68	140
MEAN	55,0	263,9	173,2	3,9	19,5	10,1	57,8	291,9	432,0	56,7	79,0
STD. DEVIATION											
5% EXCEEDENCE LIMIT	601	3034	1503	66	160	97	360	2532	3286	173	286
NO. OF BUNTONS PASSED	333,3	333,3	333,3	200	200	200	333,3	333,3	147,5	225	225
CYCLES PER BUNTON PASSED	2,05	9,10	4,51	0,33	0,80	0,48	1,08	7,60	22,27	0,77	1,26
EQUIV. RANGE APPLIED ONCE PER BUNTON PASSED (KN)	6,35	10,4	8,26	3,46	4,64	3,92	5,13	9,83	14,07	4,58	5,40
15 m/s TEST RUNS											

TABLE 4.6 : ANALYSIS OF 15 m/s TEST RUNS

MINESHAFT	HARTEBEEFSFONTEIN 6 # 105 MEN CAGE			HARTEBEEFSFONTEIN B# 105 MEN CAGE			HART. B # 5t SKIP		PRES. STEYN 4 # 10t SKIP			DEELKRAAL 1# 20t SKIP		F.S.G. 5#
	WHEEL NO.	1	3	4	2	3	4	3	4	2	3	4	2	
NO. OF SAMPLES	10	10	10	10	7	7	7	4	4	4	4	4	7	7
MEAN	586	2564	337	59	124	78	241	1930	916	1993	2395	68	140	1955
STD. DEVIATION	55,0	263,9	373,2	3,9	19,5	10,1	57,8	291,9	149,9	361,6	432,0	56,7	79,0	986,1
5% EXCEEDENCE LIMIT	688	3034	1503	66	160	97	360	2532	1225	2739	3286	173	286	3781
NO. OF BUNTONS PASSED	333,3	333,3	333,3	200	200	200	333,3	333,3	147,5	147,5	147,5	225	225	200
CYCLES PER BUNTON PASSED	2,05	9,10	4,51	0,33	0,80	0,48	1,08	7,60	8,30	18,56	22,27	0,77	1,26	18,91
EQUIV. RANGE APPLIED ONCE PER BUNTON PASSED (KN)	6,35	10,4	8,26	3,46	4,64	3,92	5,13	9,83	10,12	13,24	14,07	4,58	5,40	13,32

15 m/s TEST RUNS

TABLE 4.6 : ANALYSIS OF 15 m/s TEST RUNS

MINESHAFT	HARTEBEEFONTEIN 6 # 105 MEN CAGE				HARTEBEEFONTEIN 8 # 105 MEN CAGE				HART. B # 5t SKIP		PRES. STEYN 4 # 10t SKIP			DEELKRAAL 1 # 20t SKIP		F. S. G. 5 #
	1	3	4		2	3	4		3	4	2	3	4	2	4	
WHEEL NO.																
NO. OF SAMPLES	10	10	10		7	7	7	4	4	4	4	4	4	7	7	7
MEAN	586	2564	837		59	124	78	241	1930	916	1993	2395	68	140	1955	
STD. DEVIATION	55,0	263,9	373,2		3,9	19,5	10,1	57,8	291,9	149,9	361,6	432,0	56,7	79,0	986,1	
5% EXCEEDENCE LIMIT	684	3034	1503		66	160	97	360	2532	1225	2739	3286	173	286	3781	
NO. OF BUNITONS PASSED	333,3	333,3	333,3		200	200	200	333,3	333,3	147,5	147,5	147,5	225	225	200	
CYCLES PER BUNTON PASSED	2,05	9,10	4,51		0,33	0,80	0,48	1,08	7,60	8,30	18,56	22,27	0,77	1,26	18,91	
EQUIV. RANGE APPLIED UNCE PER BUNTON PASSED (KN)	6,35	10,4	8,26		3,46	4,64	3,92	5,13	9,83	10,12	13,24	14,07	4,58	5,40	13,32	

15 m/s TEST RUNS

TABLE 4.7 : ANALYSIS OF 10 m/s AND 5 m/s TEST RUNS

MINESHAFT	WHEEL NUMBER	PRES. STEYN 4#				DEELKRAAL		FSG
		10t SKIP	3	4	1# 20t SKIP	2	4	
10 m/s TEST RUNS	No. OF SAMPLES	4	4	4	6	4	8	
	MEAN	148	284	462	44	34	1041	
	STD. DEVIATION	29,8	84,4	119,6	17,8	12,8	224,0	
	5% EXCEEDENCE LIMIT	210	458	708	78	58	1449	
	NO. OF BUNTONS PASSED	98,3	98,3	98,3	150	150	133,3	
	CYCLES PER BUNTON PASSED	2,13	4,65	7,20	0,52	0,39	10,87	
	EQUIV. RANGE APPLIED ONCE PER BUNTON PASSED	6,43	8,35	9,66	4,02	3,65	11,08	
	NO. OF SAMPLES	4	4	4			4	
	MEAN	65	80	196			255	
	STD. DEVIATION	13,3	39,9	47,9			44,6	
5% EXCEEDENCE LIMIT	92	163	295			347		
NO. OF BUNTONS PASSED	49,2	49,2	49,2			66,7		
CYCLES PER BUNTON PASSED	1,88	3,31	5,99			5,20		
EQUIV. RANGE APPLIED ONCE PER BUNTON PASSED	6,17	7,45	9,08			8,66		

Number 8 shaft where measurements on the cage and on the skip were obtained. In fact wheel 3 of the cage and wheel 3 of the skip were against a bunton of the same stiffness but the fatigue load on the skip wheel is about 10% higher, although the skip is both smaller and lighter than the cage. This is the result of many variables but the most significant one here is probably the bunton stiffness on the opposite side of the conveyance. It is quite likely therefore that the fatigue load is significantly influenced by the sum (or ratio) of the stiffnesses of the buntons on each side of the conveyance.

It would be desirable to include for the effects of the above two aspects in the proposed formula for fatigue loading but as these effects cannot be correlated with any of the other results available at present, it would be unreasonable to include for them at this stage.

#### 4.7 Proposal of a formula for fatigue loading

With the limited, conflicting results available and without a comprehensive study of the major variables involved, the best attempt that can be made at present is to classify the shafts into good, acceptable and unacceptable shafts. The limits of this classification would be the same as those proposed by Krige<sup>1</sup> and given in Chapter 6 of his thesis. By specifying fatigue loading in terms of a load range that is applied on average once per bunton passed it would appear from Table 4.6 that for bottom wheels and conveyance speed of 15 m/s:

- a) For a good shaft a range of 5 kN is applied on average once per bunton passed.

- (1) An acceptable shaft of range of 10 kN is applied on average once per buntion passed.
- (2) On the basis of this classification the shaft condition in President Steyn Number 4 shaft skip and in Free State Geduld Number 5 shaft skip would be unacceptable.

Taking the above in mind and including for the effects of conveyance speed and guide wheel location the following formula for fatigue loading is proposed:

$$\text{Load range applied on average once per buntion passed} = 5 \cdot S_c \cdot G_w \cdot \frac{(V+10)}{25}$$

- where  $S_c$  = shaft condition factor
- \* 1,0 for good shafts
  - \* 2,0 for acceptable shafts
- $G_w$  = Guide wheel location factor
- \* 1,0 for bottom wheels
  - \* 0,71 ( $\frac{1,0}{4}$ ) for top wheels
- $V$  = conveyance speed ( $\frac{m}{s}$ )

With the limitations of the above formula it is felt that:

- (1) It does not include the buntion stiffness
- (2) It does not include the conveyance length or rather the ratio of conveyance weight to conveyance length.
- (3) It does not differentiate between skip and cage

It is suggested that for fatigue loading on buntons, when there is a significant level of preload present, and exceeds half the value of the range calculated from the proposed formula, the effect of the preload should be included, by designing for a new range which is the sum of the preload and half the value of the range calculated from the proposed formula.

4.8 Phase lag between wheel loads on opposite sides of the conveyance

An interesting exercise was carried out with the results from the cage in Hartebeesfontein Number 6 shaft. The load records for the two bottom wheels of the cage were subtracted and the fatigue loading spectrum was obtained for the record representing the difference in wheel loads. The results are tabulated in Table 4.8 in terms of equivalent cycles for a load range of 5 kN over 300,000 buntons.

TABLE 4.8 : HARTEBEEFONTein 6# CAGE-FATIGUE LOADING COMPARISONS

TEST CONDITION	WHEEL 3	WHEEL 4	3 - 4
DOWN EMP. 15 m/s	2792	784	4432
UP " "	2552	775	4925
DOWN " "	2490	656	4113
UP " "	2382	484	4113
UP " "	2323	470	4293
DOWN " "	2163	548	3665

It is seen from the results that the record representing the difference in wheel loads yields much higher fatigue loading than either of the wheels or their sum. This means that in this record higher load ranges are present corresponding to the wheel loads being out-of-phase, and when subtracted become in-phase to a fair extent. This is reasonable as it suggests that the cage pushes hard against each side alternately.

#### 4.9 Comparison between DISCS and experimentally derived fatigue loading spectra

Unfortunately only the DISCS results for the cage in Hartebeesfontein Number 6 shaft were available for this comparison. The comparison is shown in Table 4.9 where the results have been reduced to the equivalent number of cycles of a 5 kN load range per bunton passed. While it appears, on the basis of this one case, that DISCS would underestimate fatigue loading to a fair extent, it must be remembered that the steelwork in this shaft is not considered to be in good condition which explains the high fatigue loading obtained from the experimental measurements.

The cage in Hartebeesfontein Number 8 shaft which is similar in layout and detail to the cage in Number 6 shaft yields fatigue loading that is much lower and consequently more in agreement with the DISCS results.

In addition the following comments are relevant here:

- a) During the first up empty run of the site measurements the rubber lining of the wheels broke thus causing much higher forces to be applied.
- b) Wheel 3 was not replaced and was in bad condition throughout the measurements so the comparison should perhaps be limited to wheels 1 and 4.

- c) The difference in fatigue load between top and bottom wheels is not evident in the DISCS results but in a cage the centre of gravity is near the geometric centre and this effect is not very pronounced.
- d) The DISCS results do not reflect the variation with conveyance speed that was established experimentally. However the DISCS run had a significant preload (8,0 kN) and the load cycles are probably dominated by this effect i.e. a high load at each bunton irrespective of the speed of travel.

Bearing the above comments in mind it would appear that the comparison is not unreasonable but is not possible to draw any definite conclusions.

TABLE 4.9 : COMPARISON BETWEEN DISCS AND EXPERIMENTALLY  
OBTAINED FATIGUE LOADING SPECTRA  
HARTEBEEFSFONTEIN 6# 105 MEN CAGE

TEST CONDITION	MEASURED EXPERIMENTALLY			DISCS			
	WHEEL 1	3	4	WHEEL 1	2	3	4
UP FULL 15 m/s	1,857	9,132	3,678	1,257	1,281	2,317	2,145
"	1,917	8,505	2,889				
UP EMPTY 15 m/s	8,055	44,532	0,603				
"	1,908	7,656	2,325				
"	1,677	7,146	1,452				
"	1,617	6,972	1,410				
"				0,576	1,719	0,657	0,597
DOWN EMPTY 15 m/s	2,037	7,362	5,025				
"	1,680	7,809	2,376				
"	1,695	8,376	2,352				
"	1,701	7,470	1,968				
"	1,494	6,489	1,644				
FULL 7,5 m/s				1,617	0,991	1,735	1,693
EMPTY 7,5 m/s				0,996	1,283	0,776	1,246

CHAPTER 5 • CONCLUSIONS AND RECOMMENDATIONS

The analysis of fatigue loading on mineshaft steelwork was hindered to a fair extent by the limited number of experimental measurements available. In addition the conflicting nature of the results obtained further restricted this analysis. Nevertheless the following important observations were made from the experimental measurements:

- 1) Fatigue loading varies widely between different mineshafts and depends on a number of variables. An approximate correlation with some of these variables was observed on the experimental measurements.
- 2) The condition of the shaft steelwork, the sum (or ratio) of the bunton stiffness, the conveyance speed and probably the ratio of conveyance weight to overall length are the major variables affecting fatigue loading.
- 3) Fatigue loading in a particular shaft is similar for both up and down trips and for empty and fully loaded conveyance trips.
- 4) The top wheels of a conveyance are subject to fatigue loading that is about 1,4 times less than the bottom wheels.
- 5) Fatigue loading transverse to the plane of the buntons is considerable and cannot be ignored.

On the evidence of the results obtained the following recommendations can be made:

- a) Guide mis-alignment and mis-match should be kept as small as possible as this is a reflection of the condition of the shaft steelwork.
- b) Shaft layouts with short rigid buntons should be avoided.
- c) The preload level on the guide wheels should be kept as low as possible, as it contributes to the fatigue loading on the shaft steelwork.
- d) The proposed formula for fatigue loading on mine-shaft steelwork is very basic in its present form and can be greatly improved if more experimental measurements become available and with a proper study of the major variables influencing the behaviour of the shaft steelwork.

REFERENCES

1. KRIGE G J, and KEMP A R: The behaviour and design of mineshaft steelwork and conveyances: A summary of a current research programme. S A Mech. Engineer, July, 1982. Vol. 32 No. 7 pp. 163-169.
2. KRIGE G J: Behaviour and design of mineshaft steelwork and conveyances. Report 1: Survey of vertical, steel equipped mineshafts and some suggestions regarding specifications for acceptable shafts. Chamber of Mines of S A Report, February, 1981.
3. KRIGE, G J: The behaviour and design of mineshaft steelwork and conveyances. PhD thesis submitted to the University of the Witwatersrand, 1983.
4. CALVER A H: Comments on the shaft steelwork problems at N. 4 shaft at President Steyn Gold Mining Company Limited. Assoc. Mine Res. Engr. Circular 1/80, November, 1980.
5. LOUBSER R M, and BULL J R M: Loading conditions in guide and buntion systems: the problem and initial findings. S A Mechanical Engineer, April 1962.
6. LOUBSER R M, and BULL J R M: The influence of buntion configuration on the stress distribution in and strength of buntions. S A Mechanical Engineer, August, 1961.
7. REINKE, et al: A study of the dynamic loading exerted on shaft hoists: Final report. Tremonia, 1974.
8. COUNCIL FOR SCIENTIFIC AND INDUSTRIAL RESEARCH: Report MEG 706. Shaft steelwork design Code NMERI, Pretoria, September, 1968
9. PENNING F A, et al: Development of vertical shaft skip and guide design. US Bureau of Mines OFR 71-78, Publication PB 283776, June, 1977.
10. METAL FATIGUE: Theor: and design, Edited by Angel F, Madayaq.
11. DOWLING N E: Fatigue failure predictions for complicated stress-strain histories. Journal of Materials, JMLSA, Vol. 7, No. 1, March, 1972, pp.71-87

12. BRITISH STANDARD INSTITUTION: BS 5400 : Part 1 :  
1978, Steel, Concrete and composite bridges.
13. GURNEY T R: Fatigue design rules for welded steel joints. The Welding Institute Research bulletin, May, 1976.
14. GURNEY T R: Cumulative damage calculations with the proposed new fatigue design rules. Research Report, The Welding Institute, March, 1976.
15. GURNEY T R: Cumulative damage calculations taking account of low stresses in the spectrum. Research Report, The Welding Institute, March, 1976.
16. GARRETT G G: Failure by fatigue, course notes, Behaviour of Structural Materials, postgraduate course, University of the Witwatersrand, 1981.



```

DATA C(16),C(17),C(18),C(19),C(20)/'2',',','D','A','T'/'
DATA B(16),B(17),B(18),B(19),B(20)/'3',',','D','A','T'/'
OPEN(UNIT=1,NAME=B,TYPE='OLD',READONLY)
READ(1,5)(HEAD(I),I=1,30)
5   FORMAT(80A1)
READ(1,1000)DELT,VEL,MM
READ(1,1200) ISAMP
CLOSE(UNIT=1)
OPEN(UNIT=1,NAME=C,TYPE='OLD',READONLY)
READ(1,1)(HEAD(I),I=1,30)
1   FORMAT(80A1)
C
C   INITIALIZE ARRAYS
C
DO 23 K=1,4
DO 72 J=1,50
72  NC1(J,K)=0
AVL(K)=0.0
23  CL(K)=0.0
SAMP=ISAMP
24  NX=1000
IF(ISAMP.LT.1000) NX=ISAMP
C
C   READ DATA FROM DATA FILES
C
DO 19 N=1,NX
READ(1,100,END=71) (X1(N,M),M=1,MX)
71  DO 32 M=1,MX
32  CL(M)=CL(M)+X1(N,M)
19  CONTINUE
C
C   SCAN DATA TO LOCATE MIN AND MAX PEAKS, LOAD RANGES
C   AND CORRESPONDING NOS OF CYCLES
C
DO 34 M=1,MX
DO 33 I=1,NX
33  X(I)=X1(I,M)
DO 36 L=1,50
36  NC(L)=0
100 FORMAT (10F11.3)
PK(1)=X(1)
PK(2)=X(1)
PKM=X(1)
TR=X(1)
TRM=X(1)
TRF=X(1)
N=2
J=0
DO 20 I=2,NX-1
IF(X(1).EQ.X(I-1).AND.X(I+1).LT.X(I)) GO TO 22
IF(X(1).GT.X(I-1)) GO TO 21
IF(X(I+1).LE.X(I)) GO TO 20
TR=X(I)

```

```

IF (TRF.GT.TR) TRM=TR
TRF=TR
GO TO 20
21 IF (X(I+1).GE.X(I)) GO TO 20
22 K=K+1
PK(K)=X(I)
IF (PK(K-1).EQ.PK(K-2).AND.PK(K).GT.PK(K-1)) GO TO 50
IF (PK(K-1).LT.PK(K-2)) GO TO 31
IF (PK(K).GE.PK(K-1)) GO TO 40
PKM=PK(K-1)
GO TO 30
31 IF (PK(K).GT.PK(K-1)) GO TO 50
30 BJ=(PK(K)-TR)+0.5
J=BJ
GO TO 60
40 BJ=(PK(K-1)-TR)+0.5
J=BJ
GO TO 60
50 IF (TR.EQ.TRM) GO TO 70
IF (J.LE.0) GO TO 80
NC(J)=NC(J)-1
80 BJ=PK(K-1)-TR+0.5
J=BJ
IF (J.LE.0) GO TO 70
NC(J)=NC(J)+1
70 J=PKM-TRM+0.5
TRF=10.**20.
60 IF (J.LE.0) GO TO 20
NC(J)=NC(J)+1
20 CONTINUE
DO 35 L=1,50
35 NC1(L,M)=NC1(L,M)+NC(L)
34 CONTINUE
ISAMP=ISAMP-NS
DIS=DELT*(SAMP-ISAMP)*VEL
WRITE (6,104) DIS
DO 74 L=1,50
DO 73 M=1,MX
IF (NC1(L,M).EQ.0) GO TO 73
JX=L
73 CONTINUE
74 CONTINUE
WRITE(6,118)
118 FORMAT(//,T10,'LOAD RANGE',T30,'NO OF CYCLES',//)
DO 39 J=1,JX
38 WRITE (6,117) J, (NC1(J,N), N=1,MX)
117 FORMAT (T15,I3,T30,4I6)
IF (ISAMP.GT.3) GO TO 24
C
C CALCULATE MEAN LOAD
C
DO 37 I=1,MX
37 AVL(I)=CL(I)/SAMP
DIST=DELT*SAMP*VEL
C
C PRINT OUT RESULTS
L

```



```

WRITE(6,116) (HEAD(I), I=1,4)
116  FORMAT(//,T30,80A1,/,T35,'FAILURE LOAD (KN) =',
@  /,T35,21(' '),//)
WRITE(6,101)
101  FORMAT(T10,'LOAD RANGE (KN)',T42,'NO. OF CYCLE',
@  T42,13(' '),//)
IF(MX.EQ.3) GO TO 42
IF(MX.EQ.2) GO TO 43
IF(MX.EQ.1) GO TO 44
41  WRITE(6,105)
105  FORMAT(T30,'WHEEL 1',T40,'WHEEL 2',T50,'WHEEL 3',T60,'WHEEL 4',
@  /,T30,7(' '),T40,7(' '),T50,7(' '),T60,7(' '),//)
DO 51 J=1,JX
AJ=J
51  WRITE(6,106) AJ, (NC1(J,K), K=1,4)
106  FORMAT(T12,F5.1,T32,I5,T42,I5,T52,I5,T62,I5)
WRITE(6,107) (AVL(I), I=1,4)
107  FORMAT(//,T10,'MEAN LOAD (KN) =',T31,F6.2,T41,F6.2,T51,F6.2,
@  T61,F6.2)
GO TO 61
42  WRITE(6,108)
108  FORMAT(T35,'WHEEL 1',T45,'WHEEL 2',T55,'WHEEL 3',/,T35,7(' '),
@  T45,7(' '),T55,7(' '),//)
DO 52 J=1,JX
AJ=J
52  WRITE(6,109) AJ, (NC1(J,K), K=1,3)
109  FORMAT(T12,F5.1,T37,I5,T47,I5,T57,I5)
WRITE(6,110) (AVL(I), I=1,3)
110  FORMAT(//,T10,'MEAN LOAD (KN) =',T36,F6.2,T46,F6.2,T56,F6.2)
GO TO 61
43  WRITE(6,111)
111  FORMAT(T37,'WHEEL 1',T52,'WHEEL 2',/,T37,7(' '),T52,7(' '),//)
DO 53 J=1,JX
AJ=J
53  WRITE(6,112) AJ, (NC1(J,K), K=1,2)
112  FORMAT(T12,F5.1,T38,I5,T53,I5)
WRITE(6,113) (AVL(I), I=1,2)
113  FORMAT(//,T10,'MEAN LOAD (KN) =',T37,F6.2,T52,F6.2)
GO TO 61
44  DO 54 J=1,JX
AJ=J
54  WRITE(6,114) AJ, NC1(J,1)
114  FORMAT(T12,F5.1,T45,I5)
WRITE(6,115) AVL(1)
115  FORMAT(//,T10,'MEAN LOAD (KN) =',F6.2)
61  WRITE(6,104) DIST
104  FORMAT(//,T10,'LENGTH OF SHAFT CONSIDERED =',F7.1,2X,'M')
CLOSE(UNIT=1)
STOP
1000  FORMAT(3X,F12.4,F12.4,I6)
1200  FORMAT(I7)
END

```

```

WRITE(6,115) (HEAD(I),I=1,30)
115 @ FORMAT(//,T30,90A1,//,T35,'FATIGUE LOAD SPECTRUM',
/,T35,21('*'),//)
WRITE(6,101)
101 @ FORMAT(T10,'LOAD RANGE (KN)',T42,'NO. OF CYCLES',/,T10,15('*'),
T42,13('*'),//)
IF(MX.EQ.3) GO TO 42
IF(MX.EQ.2) GO TO 43
IF(MX.EQ.1) GO TO 44
41 WRITE(6,105)
105 @ FORMAT(T30,'WHEEL 1',T40,'WHEEL 2',T50,'WHEEL 3',T60,'WHEEL 4',
/,T30,7('*'),T40,7('*'),T50,7('*'),T60,7('*'),//)
DO 51 J=1,JX
AJ=J
51 WRITE(6,106) AJ, (NC1(J,K), K=1,4)
106 FORMAT(T12,F5.1,T32,I5,T42,I5,T52,I5,T62,I5)
WRITE(6,107) (AVL(I), I=1,4)
107 @ FORMAT(//,T10,'MEAN LOAD (KN) =',T31,F6.2,T41,F6.2,T51,F6.2,
T61,F6.2)
GO TO 61
42 WRITE(6,108)
108 @ FORMAT(T35,'WHEEL 1',T45,'WHEEL 2',T55,'WHEEL 3',/,T35,7('*'),
T45,7('*'),T55,7('*'),//)
DO 52 J=1,JX
AJ=J
52 WRITE(6,109) AJ, (NC1(J,K), K=1,3)
109 FORMAT(T12,F5.1,T37,I5,T47,I5,T57,I5)
WRITE(6,110) (AVL(I), I=1,3)
110 FORMAT(//,T10,'MEAN LOAD (KN) =',T36,F6.2,T46,F6.2,T56,F6.2)
GO TO 61
43 WRITE(6,111)
111 @ FORMAT(T37,'WHEEL 1',T52,'WHEEL 2',/,T37,7('*'),T52,7('*'),//)
DO 53 J=1,JX
AJ=J
53 WRITE(6,112) AJ, (NC1(J,K), K=1,2)
112 FORMAT(T12,F5.1,T38,I5,T53,I5)
WRITE(6,113) (AVL(I), I=1,2)
113 FORMAT(//,T10,'MEAN LOAD (KN) =',T37,F6.2,T52,F6.2)
GO TO 61
44 DO 54 J=1,JX
AJ=J
54 WRITE(6,114) AJ, NC1(J,1)
114 FORMAT(T12,F5.1,T45,I5)
WRITE(6,115) AVL(1)
115 FORMAT(//,T10,'MEAN LOAD (KN) =',F6.2)
61 WRITE(6,104) DIST
104 FORMAT(//,T10,'LENGTH OF SHAFT CONSIDERED =',F7.1,2X,'M')
CLOSE(UNIT=1)
STOP
1000 FORMAT(3X,F12.4,F12.4,I6)
1000 FORMAT(I7)
END

```



**Author** Fotopoulos M

**Name of thesis** An Experimental study of the dynamic loading on mineshaft steelwork with particular reference to fatigue loading 1983

***PUBLISHER:***

University of the Witwatersrand, Johannesburg

©2013

***LEGAL NOTICES:***

**Copyright Notice:** All materials on the University of the Witwatersrand, Johannesburg Library website are protected by South African copyright law and may not be distributed, transmitted, displayed, or otherwise published in any format, without the prior written permission of the copyright owner.

**Disclaimer and Terms of Use:** Provided that you maintain all copyright and other notices contained therein, you may download material (one machine readable copy and one print copy per page) for your personal and/or educational non-commercial use only.

The University of the Witwatersrand, Johannesburg, is not responsible for any errors or omissions and excludes any and all liability for any errors in or omissions from the information on the Library website.