

An analysis of the symmetries and conservation laws of some classes of nonlinear wave equations in curved spacetime geometry

S. Jamal

Supervisor: Professor A. H. Kara



A thesis submitted to the Faculty of Science, University of the Witwatersrand, in requirement for the degree Doctor of Philosophy, Johannesburg, 2013.

DECLARATION

I declare that the contents of this thesis are original, except where due references have been made. It is submitted for the degree of Doctor of Philosophy at the University of the Witwatersrand, Johannesburg. It was not submitted before for any degree or examination to any other institution.

S. Jamal

Signed at Johannesburg on the 25th day of April 2013.

Abstract

The (1+3) dimensional wave and Klein-Gordon equations are constructed using the covariant d'Alembertian operator on several spacetimes of interest. Equations on curved geometry inherit the nonlinearities of the geometry. These equations display interesting properties in a number of ways. In particular, the number of symmetries and therefore, the conservation laws reduce depending on how curved the manifold is. We study the symmetry properties and conservation laws of wave equations on Freidmann-Robertson-Walker, Milne, Bianchi, and de Sitter universes. Symmetry structures are used to reduce the number of unknown functions, and hence contribute to finding exact solutions of the equations. As expected, properties of reduction procedures using symmetries, variational structures and conservation laws are more involved than on the well known flat (Minkowski) manifold.

DEDICATION

To my mother, Shireen

“Our minds are finite, and yet even in those circumstances of finitude, we are surrounded by possibilities that are infinite, and the purpose of human life is to grasp as much as we can out of that infinitude.”

- Alfred North Whitehead

ACKNOWLEDGEMENTS

In the name of the Most Beneficent, Most Loving, all gratitude to the Sustainer of the worlds, He who enabled me to successfully complete this thesis.

I would like to express my sincere gratitude to my supervisor, Professor A. H. Kara. His vast knowledge and expertise, guidance, ideas, suggestions and technical assistance contributed greatly to the very existence of this thesis.

This work has been made possible by the financial aid received from the FRC, Faculty of Science - University of the Witwatersrand and the National Research Foundation (NRF) of South Africa. I acknowledge the Scarce Skills Scholarship (Grant number SSSS2011.06.06.661) and the Thuthuka grant from the NRF.

Finally, my deepest and greatest gratitude goes to my family, for their patience, encouragement and prayers.

S. Jamal

April 2013

Contents

Preamble	8
1 Notation and Theory	13
1.1 Introduction	13
1.2 Differential Functions	14
1.3 The Multiplier Approach	14
1.4 Fundamental Operators	15
1.5 Noether's Theorem	18
1.6 Fréchet Derivatives	19
1.7 Differential Forms	21
1.8 Spacetime Geometry	23

2	The de Sitter Spacetime	25
2.1	Introduction	25
2.2	The wave equation	28
2.3	The Klein-Gordon equation	29
2.3.1	Symmetry reduction and exact solutions	33
2.4	Special cases of $V(\psi)$ - Noether approach	35
2.5	Conclusion	39
3	The Milne Spacetime	40
3.1	Introduction	40
3.2	Lie symmetries of Gordon-type equations	41
3.2.1	Symmetry reductions	45
3.2.2	Exact solutions and boundary conditions	47
3.3	Noether symmetries of a Klein-Gordon equation	50
3.4	Multipliers of a Klein-Gordon equation	54
3.5	Conclusion	56
4	The Bianchi III Spacetime	57

4.1	Introduction	57
4.2	Symmetries of the wave equation - the multiplier approach	58
4.3	Symmetries of the wave equation - the Noether approach	59
4.3.1	Symmetry reduction and invariant solutions	63
4.4	Conclusion	65
5	The Friedmann-Robertson-Walker Spacetime	67
5.1	Introduction	67
5.2	Noether symmetries of the FRW metric	69
5.3	The wave and Klein-Gordon equation	71
5.3.1	Noether symmetries	72
5.3.2	Conserved forms	73
5.3.3	Illustrative reduction and exact solution	74
5.4	Conclusion	76
6	Higher-order Symmetries and Conservation Laws	77
6.1	Introduction	77
6.2	(1+1) Gordon-type equations	79

6.3	(1+2) Klein-Gordon equation	81
6.4	Conclusion	85
	Conclusion	86
	Bibliography	88

Preamble

The study of differential equations finds its origin from the works of Isaac Newton and Gottfried von Leibnitz and have since played significant roles in the study of natural phenomena. Newton believed in the importance of differential equations because they expressed the laws of nature [1]. In 1676, Newton wrote the famous “second letter” to Leibnitz containing his ideas about differential equations in the form of an anagram [2],



Newton (1643 - 1727)

6accdae13eff7i3l9n4o4qqr4s9t12vx.

Once deciphered, the anagram translates to Newton’s version of the fundamental theorem of calculus, “*given an equation that involves the derivative of one or more functions, find the functions.*”

It is universally recognised that geometric studies of a differential equation may lead to finding its solutions. A symmetry based method is one of the cornerstones of the geometric study of differential equations - developed in the nineteenth century by Sophus Lie. Lie’s profound contribution to mathematics was his discovery that the techniques required in solving various differential equations are just special cases of a general integration procedure based on the invariance of the equation under a

continuous group of symmetries. A symmetry of a given partial differential equation is a transformation that maps every solution of the equation into another solution of the same equation. Once a symmetry group of a system of differential equations is known, one may firstly use the defining property of such a group and construct new solutions to the system from known solutions, and thereby classify different symmetry classes of solutions. Secondly, symmetry groups can be used to classify families of differential functions depending on arbitrary parameters or functions [4]. Equations with a high degree of symmetry are useful in mathematics and physics.

In the literature, symmetry analysis is one of the most widely used techniques for finding closed form solutions of differential equations [3, 4, 5, 6, 7]. Investigations of these solutions play an important role in understanding the physical aspects of differential equations. Lie's continuous symmetry groups have applications in control theory, classical mechanics and relativity, to name a few.



Lie (1842 - 1899)

The concept of a conservation law is central to physics. Investigations surrounding classical, fluid or quantum mechanics, solid state physics, quantum field theory and even general relativity, are concerned with finding quantities left dynamically invariant. In the analysis of differential equations, conservation laws have many significant uses, particularly with regard to integrability and linearization, constants of motion, analysis of solutions and numerical solution methods.

In 1918, Emmy Noether proved two extraordinary theorems relating symmetry groups of a variational integral to properties of its associated Euler-Lagrange equations. In the first of her theorems, Noether shows how each one-parameter variational symmetry group gives rise to a conservation law, for example, energy conservation comes from the invariance of the problem under a group of time translations [8]. Noether symmetries are associated, in particular, with those differential equations which possess a Lagrangian. The Noether symmetries, which are symmetries of the Euler-Lagrange systems, have interesting applications in the study of properties of particles moving under the influence of gravitational fields. Studies have been conducted to understand Noether symmetries of Lagrangians that arise from certain pseudo-Riemannian metrics of interest [9, 10]. In recent years, Noether's theorem has been applied in different cosmological contexts. It has provided a deep basis for the understanding of global conservation laws in classical mechanics and in classical field theories [11]. Noether's work also prepared some of the ground work in understanding the conservation laws in Einstein gravity [12].



Noether (1882 - 1935)

Outline of the thesis

The goal of this manuscript is to conduct a symmetry analysis of the wave and Klein-Gordon equations on various curved spacetimes, present some conserved forms associated with the symmetries and establish invariant solutions to the underlying equations. This thesis is a compilation of several published articles.

Chapter 1 describes the fundamental notation and theory used throughout this thesis. All pertinent results and definitions are stated here.

In Chapter 2, we investigate the symmetries of the wave and Klein-Gordon equation in de Sitter spacetime. We construct solutions of these equations and find conservation laws associated with Noether symmetries. We also identify Noether symmetries of the Lagrangian with those of the Killing vectors of the underlying spacetime [13]. We compliment the analysis involving the ‘fundamental’ solutions of the Klein-Gordon equation in de Sitter spacetimes given by [14].

The results of Chapter 2 have been published [15].

In Chapter 3, we present and analyse the Lie point symmetries of a class of Gordon-type equations that arise in the Milne spacetime. Using the Lie point symmetries, we reduce the Gordon-type equations using the method of invariants, and obtain exact solutions corresponding to some boundary values. The Noether point symmetries and conservation laws are obtained for the Klein-Gordon equation in one case. Finally, we investigate the existence of higher-order variational symmetries of a projection of the Klein-Gordon equation using the multiplier approach.

The results presented in Chapter 3 have been accepted for publication [16].

Chapter 4 is divided into two sections.

Section 4.2 provides the details of an analysis of the wave equation in Bianchi III spacetime using the multiplier approach. Multipliers of the wave equation are constructed and the associated conserved densities are derived.

The results of section 4.2 have been published [17].

In section 4.3 of Chapter 4, we investigate the wave equation in Bianchi III spacetime using variational techniques. We construct a Lagrangian of the model, calculate and classify the Noether symmetry generators and construct corresponding conserved forms. A reduction of the underlying equations is performed to obtain invariant solutions.

The results of section 4.3 have been published [18].

In Chapter 5, a symmetry analysis of the Friedmann-Robertson-Walker spacetime and nonlinear wave equations in this geometry are performed. Conserved forms for the wave equation are constructed by the application of Noether's theorem. We illustrate how the symmetry structure is used to reduce the wave equation leading to some exact solutions.

Chapter 5 has been submitted for publication [19].

In Chapter 6, a class of multi-dimensional Gordon-type equations are analysed using a multiplier approach to construct conservation laws. The main focus is the analysis of classical versions of the Gordon-type equations and the construction of higher-order variational symmetries and the corresponding conserved quantities. The results are extended to the multi-dimensional Gordon-type equations with the (1+2) dimensional Klein-Gordon equation in particular yielding interesting results.

Chapter 6 has been published [20].

Chapter 1

Notation and Theory

1.1 Introduction

The celebrated Noether's theorem [8, 21, 22] is an elegant and systematic way of determining conservation laws for systems of Euler-Lagrange equations once their Noether symmetries are known. This theorem relies on the availability of a Lagrangian and many works have been devoted to the inverse problem in the calculus of variation, i.e., to determine when a differential equations system has a Lagrangian formulation for a suitable Lagrangian function, for example [23]. The Euler and Lie-Bäcklund operators play a fundamental role in the investigation of algebraic properties in variational calculus and differential equations [5, 24, 25, 26]. This thesis contains Noether, Lie and multiplier approaches [3, 27] for finding symmetries of the partial differential equations under investigation. All the definitions below can be found in [4] and references therein. In brief, we mention some concepts from differential geometry and tensor calculus. Only results pertinent to our study are

provided - relating to the geometrical properties of curved spacetime. The summation convention is adopted throughout.

1.2 Differential Functions

Intrinsic to a Lie algebraic treatment of differential equations is the universal space \mathcal{A} [4, 24]. A locally analytic function $f(x, u, u_{(1)}, \dots, u_{(k)})$ of a finite number of variables is called a *differential function of order k* . The variables $u_{(1)}, u_{(2)}, \dots, u_{(k)}$ denote the collections of all first, second, \dots , k th-order partial derivatives, respectively, that is

$$u_i^\alpha = D_i(u^\alpha), \quad u_{ij}^\alpha = D_j D_i(u^\alpha), \dots$$

with the total differentiation operator with respect to x^i given by,

$$D_i = \frac{\partial}{\partial x^i} + u_i^\alpha \frac{\partial}{\partial u^\alpha} + u_{ij}^\alpha \frac{\partial}{\partial u_j^\alpha} + \dots, \quad i = 1, \dots, n. \quad (1)$$

The space \mathcal{A} is the vector space of all differential functions of all finite orders and forms an algebra. A total derivative converts any differential function of order k to a differential function of order $k + 1$. Hence, the space \mathcal{A} is closed under total derivations D_i .

1.3 The Multiplier Approach

Consider an r th-order system of partial differential equations of n independent variables $x = (x^1, x^2, \dots, x^n)$ and m dependent variables $u = (u^1, u^2, \dots, u^m)$

$$G^\mu(x, u, u_{(1)}, \dots, u_{(r)}) = 0, \quad \mu = 1, \dots, \tilde{m}. \quad (2)$$

A current $\Phi = (\Phi^1, \dots, \Phi^n)$ is conserved if it satisfies

$$D_i \Phi^i = 0 \tag{3}$$

along the solutions of (2). It can be shown [28] that every admitted conservation law arises from *multipliers* $Q_\mu(x, u, u_{(1)}, \dots)$ such that

$$Q_\mu G^\mu = D_i \Phi^i \tag{4}$$

holds identically (i.e., off the solution space) for some current Φ^i . The conserved current may then be obtained by the homotopy operator.

The continuous homotopy operator is a powerful tool that can be used to compute densities and fluxes explicitly. It allows one to invert the total divergence operator D_i , by computing higher variational derivatives followed by a one-dimensional integration with respect to a single auxiliary parameter [3, 30]. This operator can be applied to problems in which integration by parts of arbitrary functions in multi-variables is essential. A literature search done by the authors of [29] revealed that homotopy operators are used in integrability testing and inversion problems involving partial differential equations, differential-difference equations, lattices and beyond.

1.4 Fundamental Operators

Definition 1. The Euler operator, is defined by

$$\frac{\delta}{\delta u^\alpha} = \frac{\partial}{\partial u^\alpha} + \sum_{s \geq 1} (-1)^s D_{i_1} \cdots D_{i_s} \frac{\partial}{\partial u_{i_1 \dots i_s}^\alpha}, \quad \alpha = 1, \dots, m. \tag{5}$$

The terms Euler operator and variational derivative may be used interchangeably.

A variational problem consists of finding the extrema (maxima or minima) of a *functional*

$$\mathcal{L}[u] = \int_{\Omega} L(x, u_{(n)}) dx,$$

in some class of functions $u = f(x)$ defined over Ω , where $\Omega \subset X$ is an open, connected subset with smooth boundary $\partial\Omega$ (we consider the Euclidean space with $X = R^n$). The integrand $L(x, u_{(n)})$, called the Lagrangian of the variational problem \mathcal{L} , is a smooth function of x, u and various derivatives of u [4]. A formal definition of a Lagrangian follows.

Definition 2. If there exists a function $L = L(x, u, u_{(1)}, u_{(2)}, \dots, u_{(s)}) \in \mathcal{A}$; $s \leq r$, r being the order of (2), such that

$$\frac{\delta L}{\delta u^\alpha} = 0, \quad \alpha = 1, \dots, \tilde{m}$$

then L is called a Lagrangian of (2) and $\frac{\delta}{\delta u^\alpha}$ is the corresponding Euler operator in (5). $\frac{\delta L}{\delta u^\alpha} = 0$ are known as the Euler-Lagrange equations.

Definition 3. The Lie-Bäcklund operator is given by

$$X = \xi^i \frac{\partial}{\partial x^i} + \eta^\alpha \frac{\partial}{\partial u^\alpha}, \quad \xi^i, \eta^\alpha \in \mathcal{A}. \quad (6)$$

This operator is an abbreviated form of the following infinite formal sum

$$X = \xi^i \frac{\partial}{\partial x^i} + \eta^\alpha \frac{\partial}{\partial u^\alpha} + \sum_{s \geq 1} \zeta_{i_1 \dots i_s}^\alpha \frac{\partial}{\partial u_{i_1 \dots i_s}^\alpha}, \quad (7)$$

where the additional coefficients are determined uniquely by the prolongation formulae

$$\begin{aligned} \zeta_i^\alpha &= D_i(W^\alpha) + \xi^j u_{ij}^\alpha, \\ \zeta_{i_1 \dots i_s}^\alpha &= D_{i_1} \dots D_{i_s}(W^\alpha) + \xi^j u_{j i_1 \dots i_s}^\alpha, \quad s > 1. \end{aligned} \quad (8)$$

In (8), W^α is the Lie characteristic function given by

$$W^\alpha = \eta^\alpha - \xi^j u_j^\alpha. \quad (9)$$

One can write the Lie-Bäcklund (7) in the characteristic form

$$X = \xi^i D_i + W^\alpha \frac{\partial}{\partial u^\alpha} + \sum_{s \geq 1} D_{i_1} \dots D_{i_s} (W^\alpha) \frac{\partial}{\partial u_{i_1 \dots i_s}^\alpha}. \quad (10)$$

Definition 4. X is a Lie point symmetry if ξ and η in (6) are functions of x and u and are independent of derivatives of u .

A Lie (point) symmetry is characterised by an infinitesimal transformation which leaves the given differential equation invariant under the transformation of all independent and dependent variables. In this thesis, we refer only to point operators. A vast amount of work has been published in the literature studying partial differential equations in terms of the Lie point symmetries admitted by them. These symmetries play an important role in finding exact analytical solutions of the nonlinear partial differential equations, and represent physical features of the equations via the conservation laws they admit.

Definition 5. Lie-Bäcklund operators \tilde{X} and X are said to be *equivalent* if

$$X - \tilde{X} = \lambda^i D_i, \quad \lambda^i \in \mathcal{A}.$$

In particular, a generalized operator of the form $\tilde{X} = Q^\alpha \partial / \partial u^\alpha + \dots$, where $Q^\alpha \in \mathcal{A}$, is called a *canonical* or *evolutionary* representation of X , and Q^α is called its *characteristic*.

Definition 6. The Noether operator associated with a Lie-Bäcklund operator X

is given by

$$N^i = \xi^i + W^\alpha \frac{\delta}{\delta u_i^\alpha} + \sum_{s \geq 1} D_{i_1} \cdots D_{i_s}(W^\alpha) \frac{\delta}{\delta u_{i_1 \dots i_s}^\alpha}, \quad i = 1, \dots, n, \quad (11)$$

where the Euler-Lagrange operators with respect to derivatives of u^α are obtained from (5) by replacing u^α by the corresponding derivatives, e.g.,

$$\frac{\delta}{\delta u_i^\alpha} = \frac{\partial}{\partial u_i^\alpha} + \sum_{s \geq 1} (-1)^s D_{j_1} \cdots D_{j_s} \frac{\partial}{\partial u_{i j_1 \dots j_s}^\alpha} \quad i = 1, \dots, n, \quad \alpha = 1, \dots, m. \quad (12)$$

The Euler, Lie-Bäcklund and Noether operators are connected by the operator identity

$$X + D_i(\xi^i) = W^\alpha \frac{\delta}{\delta u^\alpha} + D_i N^i. \quad (13)$$

Definition 7. A Lie-Bäcklund operator X of the form (6) is called a Noether symmetry corresponding to a Lagrangian $L \in \mathcal{A}$, if there exists a vector $B^i = (B^1, \dots, B^n)$, $B^i \in \mathcal{A}$, such that

$$X(L) + LD_i(\xi^i) = D_i(B^i). \quad (14)$$

If $B^i = 0$ ($i = 1, \dots, n$), then X is called a strict Noether symmetry corresponding to a Lagrangian $L \in \mathcal{A}$.

1.5 Noether's Theorem

Noether [8] discovered the interesting link between symmetries and conservation laws, showing that for every infinitesimal transformation admitted by the action integral of a system, there exists a conservation law. That is, for any Noether

symmetry X corresponding to a given Lagrangian $L \in \mathcal{A}$, there exists a current $\Phi^i = (\Phi^1, \dots, \Phi^n)$, $\Phi^i \in \mathcal{A}$, defined by

$$\Phi^i = B^i - N^i(L), \quad i = 1, \dots, n, \quad (15)$$

which is a conserved current of the Euler-Lagrange equations $\frac{\delta L}{\delta u^\alpha} = 0$, where N^i and B^i are defined above, see also [8, 4, 31, 32].

There are several other methods developed for the construction of symmetries and conservation laws, including the partial Noether theorem [33] for non-variational problems and the multiplier method discussed above.

1.6 Fréchet Derivatives

Definition 8. Let $G, G \in \mathcal{A}$, be a system of differential equations. A recursion operator for G is a linear operator $\mathfrak{R} : \mathcal{A}^q \rightarrow \mathcal{A}^q$ in the space of q -tuples of differential functions, with the property that whenever $X = Q\partial_u$ is an evolutionary vector field of G , so is $X = \tilde{Q}\partial_u$ with $\tilde{Q} = \mathfrak{R}Q$.

Proposition 1. Let $\Gamma, \Gamma \in \mathcal{A}$, be a linear system of differential functions, with Γ denoting a linear differential operator. A second linear differential operator $\mathfrak{R} : \mathcal{A}^q \rightarrow \mathcal{A}^q$ not depending on u or its derivatives is a recursion operator for Γ , if and only if $Q = \mathfrak{R}[u]$ is the characteristic of a ‘linear’ generalized symmetry to the system.

Definition 9. Consider the differential functions G in (2). The *Fréchet derivative* of G is the differential operator $D_G : \mathcal{A}^q \rightarrow \mathcal{A}^r$ defined so that

$$D_G(Q) = \left. \frac{d}{d\epsilon} \right|_{\epsilon=0} G[u + \epsilon Q[u]]$$

for any $Q \in \mathcal{A}^q$. More simply, to evaluate $D_G(Q)$, we replace u and the derivatives of u in $G[u]$ by $u + \epsilon Q$ and then differentiate the resulting expression with respect to ϵ .

Definition 10. If

$$\mathcal{D} = \sum_J P_J[u] D_J, \quad P_J \in \mathcal{A},$$

is a differential operator, then the adjoint of \mathcal{D} is the differential operator \mathcal{D}^* which satisfies

$$\int_{\Omega} P \cdot \mathcal{D}Q dx = \int_{\Omega} Q \cdot \mathcal{D}^* P dx$$

for every pair of differential functions $P, Q \in \mathcal{A}$, which vanish when: $u = 0$, every domain $\Omega \subset R^n$ and every function $u = f(x)$ of compact support in Ω . It can also be shown by integration by parts that

$$\mathcal{D}^* = \sum_J (-D)_J \cdot P_J,$$

meaning that for any $Q \in \mathcal{A}$,

$$\mathcal{D}^* Q = \sum_J (-D)_J [P_J[Q]] \quad (\text{see}[4]).$$

The following theorem defines the condition under which a symmetry is variational.

Theorem 1. For variational partial differential equations, $E = 0$, where $E \in \mathcal{A}$, an evolutionary vector field $\mathcal{X} = Q\partial_u$ is a variational symmetry if and only if $\mathcal{X}E + A\mathcal{F}_Q E = 0$, where $A\mathcal{F}_Q$ is the adjoint *Fréchet derivative* on Q [4].

1.7 Differential Forms

In this section, we briefly outline the notation and pertinent results used in Chapter 4 - section 4.3. Some of the results and definitions presented above may be written in the notation of differential forms [23]. We review the definitions relating to Lie-Bäcklund, strict Noether symmetries and conserved forms (see [24, 34] and references therein). The language of differential forms provide a classical way of defining operators. The convention that repeated indices imply summation is used.

Let $x = (x^1, x^2, \dots, x^n) \in R^n$ be the independent variable with x^i , and let $u = (u^1, u^2, \dots, u^m) \in R^m$ be the dependent variable with coordinates u^α . Furthermore, let $\pi : R^{n+m} \rightarrow R^n$ be the projection map $\pi(x, u) = x$. Also, suppose that $s : \chi \subset R^n \rightarrow \mathcal{U} \subset R^{n+m}$ is a smooth map such that $\pi \circ s = 1_\chi$, where 1_χ is the identity map on χ . The r -jet bundle $\mathcal{J}^r(\mathcal{U})$ is given by the equivalence classes of sections of \mathcal{U} . The coordinates on $\mathcal{J}^r(\mathcal{U})$ are denoted by $(x^i, u^\alpha, \dots, u_{i_1 \dots i_r}^\alpha)$, where $1 \leq i_1 \leq \dots \leq i_r \leq n$ and $u_{i_1 \dots i_r}^\alpha$ corresponds to the partial derivatives of u^α with respect to x^{i_1}, \dots, x^{i_r} .

The r -jet bundle on \mathcal{U} will be written as $\mathcal{J}^r(\mathcal{U}) = \{(x, u, u_{(1)}, \dots, u_{(r)}) / (x, u) \in \mathcal{U}\}$. We now review the space of differential forms on $\mathcal{J}^r(\mathcal{U})$. To this end, let $\Omega_k^r(\mathcal{U})$ be the vector space of differential k -forms on $\mathcal{J}^r(\mathcal{U})$ with differential d . A smooth differential k -form on $\mathcal{J}^r(\mathcal{U})$ is given by

$$\omega = f_{i_1, i_2, \dots, i_k} dx^{i_1} \wedge dx^{i_2} \wedge \dots \wedge dx^{i_k}$$

where each component $f_{i_1, i_2, \dots, i_k} \in \Omega_0^r(\mathcal{U})$. Note that for differential functions $f \in \Omega_0^r(\mathcal{U})$,

$$Df = D_j f dx^j \tag{16}$$

where D is the total differential or the total exterior derivative. Moreover, the total

exterior derivative of ω is

$$D\omega = Df_{i_1, i_2, \dots, i_k} dx^{i_1} \wedge dx^{i_2} \wedge \dots \wedge dx^{i_k}$$

and by invoking (16) one has

$$D\omega = Df_{i_1, i_2, \dots, i_k} dx^j \wedge dx^{i_1} \wedge dx^{i_2} \wedge \dots \wedge dx^{i_k}.$$

The total differential D has properties analogous to the algebraic properties of the usual exterior derivative d ,

$$D(\omega \wedge v) = D\omega \wedge v + (-1)^k \omega \wedge Dv$$

for ω a k -form and v an l -form and $D(D\omega) = 0$. Also, it is known that if $D(D\omega) = 0$, then ω is a locally exact k -form, i.e., $\omega = Dv$ for some $(k - 1)$ -form v [35].

Definition 11. A conserved form of (2) is a differential $(n - 1)$ -form

$$\omega = \Phi^i(x, u, u_{(1)}, \dots, u_{(r-1)}) \left(\frac{d}{dx^i} \Big| (dx^1 \wedge \dots \wedge dx^n) \right) \quad (17)$$

defined on $\mathcal{J}^{r-1}(\mathcal{U})$ if

$$D\omega = 0 \quad (18)$$

is satisfied on the surface given by (2).

Remark. When Definition 11 is satisfied, (18) is called a conservation law of (2).

It is clear that (18) evaluated on the surface (2) implies

$$D_i \Phi^i = 0 \quad (19)$$

on the surface given by (2), which is also referred to as a conservation law of (2). The tuple $\Phi = (\Phi^1, \dots, \Phi^n)$, $\Phi^j \in \Omega_0^{r-1}(\mathcal{U})$ ($j = 1, \dots, n$), is called a conserved vector of (2).

Let $\mathcal{A} = \bigcup_{r=0}^p \Omega_0^r(\mathcal{U})$ for some $p < \infty$. Then \mathcal{A} is the universal space of differential functions of finite orders defined also in section 1.2.

If X is a Lie-Bäcklund operator (6), ω a k -form and v an l -form, then

$$X(\omega \wedge v) = X(\omega) \wedge v + \omega \wedge X(v).$$

Recall Definition 7, which stated that X is called a strict Noether symmetry corresponding to a Lagrangian $L \in \mathcal{A}$. This case is also obtained by setting the Lie derivative on the n -form $Ldx^1 \wedge \dots \wedge dx^n$ in the direction of X to zero, i.e.,

$$\mathcal{L}_X Ldx^1 \wedge \dots \wedge dx^n = X(Ldx^1 \wedge \dots \wedge dx^n) = 0,$$

where \mathcal{L} is the Lie derivative operator.

1.8 Spacetime Geometry

The idea of Einstein's theory of relativity is that there is no clear physical distinction between space and time [13]. Time and space form together a continuum (or manifold) of spacetime. Manifolds form fundamental objects in the field of differential geometry wherein they generalize the familiar concepts of curves and surfaces in three-dimensional space. In general, a manifold is a space that locally resembles the Euclidean space, but globally may not. In the context of general relativity, the manifold is where every point (within a small finite neighbourhood) can be fixed uniquely by the specification of four co-ordinates x^n , and to study physics on manifolds, one needs to measure the spatial and temporal separation of neighbouring points - this requires a metric [36]. There is an overwhelming amount of observational evidence that the universe is expanding and metrics enables us to make quantitative predic-

tions in an expanding universe [37]. In differential geometry, metrics deal with the geometric distortion of curved vector spaces.

In general we have

$$ds^2 = g_{\mu\nu}(x^i)dx^\mu dx^\nu,$$

where μ and ν take on the range $(0, 1, 2, 3)$ and represent components of tensors, with $dx^0 = dt$ reserved for the *timelike* coordinate, and the rest refer to the *spacelike* coordinates. Summation occurs over Latin indices appearing twice.

The metric $g_{\mu\nu}$ is symmetric, its determinant g is in general different from zero, it possess an inverse $g^{i\mu}$ and it provides the connection between the values of the coordinates and the more physical measure of the interval ds^2 [36]. Thus,

$$g_{\mu\nu} = g_{\nu\mu}, \quad |g_{\mu\nu}| = g \neq 0, \quad g^{i\mu}g_{\mu\nu} = \delta_\nu^i = g_\nu^i,$$

where δ_ν^i is the Kronecker delta,

$$\delta_\nu^i = \begin{cases} 1 & : i = \nu \\ 0 & : i \neq \nu. \end{cases}$$

The space under consideration is said to be *pseudo - Riemannian*, ds^2 can be positive (spacelike), negative (timelike) or null (lightlike), it is a Lorentzian metric [36]. Christoffel symbols or connection coefficients are important quantities in Riemannian geometry and are related to the metric by

$$\Gamma_{\alpha\beta}^\mu = \frac{1}{2}g^{\mu\nu} \left(\frac{\partial g_{\alpha\nu}}{\partial x^\beta} + \frac{\partial g_{\beta\nu}}{\partial x^\alpha} - \frac{\partial g_{\alpha\beta}}{\partial x^\nu} \right).$$

The d'Alembertian operator plays a crucial role in wave mechanics. Its covariant form is

$$\square u = \frac{1}{\sqrt{|-g|}} \frac{\partial}{\partial x^\mu} \left(\sqrt{|-g|} g^{\mu\nu} \frac{\partial}{\partial x^\mu} u \right).$$

Chapter 2

The de Sitter Spacetime

2.1 Introduction

The Einstein theory of general relativity is a field theory of gravitation [13]. The equations that represent the theory are known as Einstein field equations,

$$R_{\mu\nu} - \frac{1}{2}g_{\mu\nu}R = -8\pi GT_{\mu\nu} - \lambda g_{\mu\nu},$$

where $g_{\mu\nu}$, $R_{\mu\nu}$, and $T_{\mu\nu}$ respectively represent metric, Ricci and energy-momentum tensors. The $\lambda g_{\mu\nu}$ is interpreted as energy-momentum of the vacuum and R is called the Ricci scalar. The geometrical significance of the solutions of the Einstein's equations lies in its prediction of singularities such as black holes [38]. In order to understand the effect of gravity on the solutions of the wave equation, work has recently been published in the literature by solving the wave equation in various spacetime geometries [39].

In [40], the authors discuss solutions of the wave equation in the de Sitter - Schwarzschild

metric. Dafermos and Rodnanski [38] dealt with solutions of the linear wave equation $\square_g \phi = 0$ on a non-extremal maximally extended Schwarzschild-de Sitter spacetime. Yagdjian and Galstian [14, 41] discussed the fundamental solutions of the wave and Klein-Gordon equation arising in the de Sitter model of the universe. They used the fundamental solutions to discuss the Cauchy problem and proved some decay estimates for the solutions of the equation. It is noted that the de Sitter model of the universe is of interest in relativity for its particle creation and the vacuum stress have been explicitly evaluated [42, 14]. The authors of [43] showed that the de Sitter model gives an explanation of the actual red shift of spectral lines observed by Hubble and Humanson. Results on the decay of local energy for wave and Klein-Gordon equations may possibly prove the global nonlinear stability of these spacetimes [14].

The plan of the chapter is as follows. In sections 2.2 - 2.3, we derive Lie point symmetries of the wave and Klein-Gordon equation in de Sitter spacetime. We also illustrate the reduction of the Klein-Gordon equation corresponding to a specific potential function. In section 2.4, we briefly describe the notion of Noether symmetries and its relation to conservation laws, and consider some special potential functions.

If we consider the spacetime metric

$$ds^2 = -dt^2 + a^2(t)(dx^2 + dy^2 + dz^2), \quad (20)$$

where $a(t)$ is an appropriate scale factor, then under the assumption of FLRW (Friedmann - Lemaître - Robertson - Walker), the de Sitter model is [14]

$$a(t) = a(0)e^{\sqrt{\frac{\Lambda}{3}}t}.$$

The de Sitter line element is given by

$$ds^2 = -dt^2 + e^{2Ht}(dx^2 + dy^2 + dz^2), \quad (21)$$

where $H = \sqrt{\Lambda/3}$ is the Hubble constant.

Generally, the matter fields described by a function ψ must satisfy equations of motion and in the *massive* scalar field case, the equation of motion is that ψ satisfies the Klein-Gordon equation generated by the metric g [14],

$$\frac{1}{\sqrt{|-g|}} \frac{\partial}{\partial x^i} \left(\sqrt{|-g|} g^{ik} \frac{\partial \psi}{\partial x^k} \right) = m^2 \psi + V'(\psi). \quad (22)$$

In the de Sitter universe, the equation for the scalar field with mass m and potential function V written out explicitly in coordinates is [14]

$$\psi_{tt} + nH\psi_t - e^{-2Ht} \Delta \psi + m^2 \psi = -V'(\psi), \quad (23)$$

where $x \in R^n$, $t \in R$, Δ denotes the Laplacian.

If we consider the equation for the *massless* scalar field with $H = 1$, the Klein-Gordon equation (23) reduces to the wave equation with potential function V , i.e.,

$$\psi_{tt} + n\psi_t - e^{-2t} \Delta \psi = -V'(\psi), \quad (24)$$

We consider two typical forms of the potential functions (see [14]) with $n = 3$ (three dimensional space) for equations (23) and (24) in our symmetry study, namely,

$$\text{CASE I. } V(\psi) = 0,$$

$$\text{CASE II. } V(\psi) = \psi^4.$$

In the underlying calculations, it turns out that the case $V(\psi) = \psi^4$ is special in the context of symmetry algebras.

2.2 The wave equation

It is well known that a generator X is a Lie point symmetry of the equation (24) if

$$X[\psi_{tt} + n\psi_t - e^{-2t}\Delta\psi + V'(\psi)] = 0, \quad (25)$$

along the solutions of (24), where X is defined by (7) and prolonged to second-order using (8). Equation (25) separates into a system of overdetermined, linear partial differential equations giving rise to a finite dimensional vector space of symmetries. The resultant space is both a Lie algebra and a Lie group. The calculations are long and tedious and we present only the results here - the details for the calculations are available to the reader in a number of texts that have been cited here. The procedure is standard and is used in all of the subsequent cases below.

CASE I. $V(\psi) = 0$. It can be shown that equation (24) admits a 12-dimensional Lie algebra of point symmetry generators with a basis (Lie symmetries) given by

$$\begin{aligned} X_1 &= \partial_x, \\ X_2 &= \partial_y, \\ X_3 &= x\partial_y - y\partial_x, \\ X_4 &= \partial_z, \\ X_5 &= x\partial_z - z\partial_x, \\ X_6 &= y\partial_z - z\partial_y, \\ X_7 &= -2x\partial_t + 2xy\partial_y + 2xz\partial_z + (e^{-2t} + x^2 - y^2 - z^2)\partial_x, \\ X_8 &= 2xy\partial_x - 2y\partial_t + 2yz\partial_z + (e^{-2t} - x^2 + y^2 - z^2)\partial_y, \\ X_9 &= -2xz\partial_x - 2yz\partial_y + 2z\partial_t + (-e^{-2t} + x^2 + y^2 - z^2)\partial_z, \\ X_{10} &= \psi\partial_\psi, \\ X_{11} &= \mathcal{F}_1(t, x, y, z)\partial_\psi, \\ X_{12} &= -2\partial_t + 2x\partial_x + 2y\partial_y + 2z\partial_z + \psi\partial_\psi, \end{aligned}$$

where

$$\mathcal{F}_{1zz} + \mathcal{F}_{1yy} + \mathcal{F}_{1xx} - 3e^{2t}\mathcal{F}_{1t} - e^{2t}\mathcal{F}_{1tt} = 0.$$

CASE II. $V(\psi) = \psi^4$. Equation (24) admits 10 Lie point symmetries, viz., X_1 to X_9 from CASE I and $\bar{X}_{10} = -\partial_t + x\partial_x + y\partial_y + z\partial_z$.

2.3 The Klein-Gordon equation

CASE I. $V(\psi) = 0$. The Lie point symmetries of (23) split into the following three subcases.

(1) $H \neq 0, m = -\sqrt{2}H$

$$X_1^1 = \partial_x,$$

$$X_2^1 = \partial_y,$$

$$X_3^1 = x\partial_y - y\partial_x,$$

$$X_4^1 = \partial_z,$$

$$X_5^1 = x\partial_z - z\partial_x,$$

$$X_6^1 = y\partial_z - z\partial_y,$$

$$X_7^1 = \sqrt{2}mx\partial_x + \sqrt{2}my\partial_y + \sqrt{2}mz\partial_z + 2\partial_t,$$

$$X_8^1 = 2\sqrt{2}mxy\partial_y + 2\sqrt{2}mzx\partial_z + 4x\partial_t + \frac{\sqrt{2}(2e^{\sqrt{2}mt} + m^2(x^2 - y^2 - z^2))}{m}\partial_x,$$

$$X_9^1 = \frac{2\sqrt{2}y}{m}\partial_t + 2xy\partial_x + 2yz\partial_z + \left(\frac{2e^{\sqrt{2}mt}}{m^2} - x^2 + y^2 - z^2\right)\partial_y,$$

$$X_{10}^1 = \frac{2\sqrt{2}z}{m}\partial_t + 2xz\partial_x + 2yz\partial_y + \left(\frac{2e^{\sqrt{2}mt}}{m^2} - x^2 - y^2 + z^2\right)\partial_z,$$

$$X_{11}^1 = \psi\partial_\psi,$$

$$X_{12}^1 = \mathcal{F}_1(t, x, y, z)\partial_\psi,$$

$$X_{13}^1 = \frac{\sqrt{2}e^{-\frac{mt}{\sqrt{2}}}}{m}\partial_t + e^{-\frac{mt}{\sqrt{2}}}\psi\partial_\psi,$$

$$\begin{aligned}
X_{14}^1 &= 2e^{-\frac{mt}{\sqrt{2}}}\partial_t + \sqrt{2}e^{-\frac{mt}{\sqrt{2}}}m\psi\partial_\psi, \\
X_{15}^1 &= \frac{2\sqrt{2}e^{\frac{mt}{\sqrt{2}}}}{m}\partial_x + \sqrt{2}e^{-\frac{mt}{\sqrt{2}}}mx\psi\partial_\psi + 2e^{-\frac{mt}{\sqrt{2}}}x\partial_t, \\
X_{16}^1 &= \frac{2\sqrt{2}e^{\frac{mt}{\sqrt{2}}}}{m}\partial_y + \sqrt{2}e^{-\frac{mt}{\sqrt{2}}}my\psi\partial_\psi + 2e^{-\frac{mt}{\sqrt{2}}}y\partial_t, \\
X_{17}^1 &= \frac{2\sqrt{2}e^{\frac{mt}{\sqrt{2}}}}{m}\partial_z + \sqrt{2}e^{-\frac{mt}{\sqrt{2}}}mz\psi\partial_\psi + 2e^{-\frac{mt}{\sqrt{2}}}z\partial_t, \\
X_{18}^1 &= \frac{2e^{-\frac{mt}{\sqrt{2}}}(2e^{\sqrt{2}mt}+m^2(x^2+y^2+z^2))}{m^2}\partial_t - \frac{\sqrt{2}e^{-\frac{mt}{\sqrt{2}}}(2e^{\sqrt{2}mt}-m^2(x^2+y^2+z^2))\psi}{m}\partial_\psi + \frac{4\sqrt{2}e^{\frac{mt}{\sqrt{2}}}x}{m}\partial_x + \\
&\quad \frac{4\sqrt{2}e^{\frac{mt}{\sqrt{2}}}y}{m}\partial_y + \frac{4\sqrt{2}e^{\frac{mt}{\sqrt{2}}}z}{m}\partial_z,
\end{aligned}$$

where

$$-2m^2\mathcal{F}_1(t, x, y, z) + 2e^{\sqrt{2}mt}\mathcal{F}_{1zz} + 2e^{\sqrt{2}mt}\mathcal{F}_{1yy} + 2e^{\sqrt{2}mt}\mathcal{F}_{1xx} + 3\sqrt{2}m\mathcal{F}_{1t} - 2\mathcal{F}_{1tt} = 0.$$

(2) $H \neq 0, m = \sqrt{2}H$

In this subcase, we obtain an 18-dimensional Lie algebra, where the symmetries X_1^1 to X_6^1 above, are common to this case and the other symmetries are

$$\begin{aligned}
X_7^2 &= \sqrt{2}mx\partial_x + \sqrt{2}my\partial_y + \sqrt{2}mz\partial_z - 2\partial_t, \\
X_8^2 &= -2\sqrt{2}mxy\partial_y - 2\sqrt{2}mzx\partial_z + 4x\partial_t - \frac{\sqrt{2}(2e^{-\sqrt{2}mt}+m^2(x^2-y^2-z^2))}{m}\partial_x, \\
X_9^2 &= \frac{2\sqrt{2}y}{m}\partial_t - 2xy\partial_x - 2yz\partial_z - \left(\frac{2e^{-\sqrt{2}mt}}{m^2} - x^2 + y^2 - z^2\right)\partial_y, \\
X_{10}^2 &= \frac{2\sqrt{2}z}{m}\partial_t - 2xz\partial_x - 2yz\partial_y - \left(\frac{2e^{-\sqrt{2}mt}}{m^2} - x^2 - y^2 + z^2\right)\partial_z, \\
X_{11}^2 &= \psi\partial_\psi, \\
X_{12}^2 &= \mathcal{F}_1(t, x, y, z)\partial_\psi, \\
X_{13}^2 &= \frac{\sqrt{2}e^{\frac{mt}{\sqrt{2}}}}{m}\partial_t - e^{\frac{mt}{\sqrt{2}}}\psi\partial_\psi, \\
X_{14}^2 &= -2e^{\frac{mt}{\sqrt{2}}}\partial_t + \sqrt{2}e^{\frac{mt}{\sqrt{2}}}m\psi\partial_\psi, \\
X_{15}^2 &= \frac{2\sqrt{2}e^{-\frac{mt}{\sqrt{2}}}}{m}\partial_x + \sqrt{2}e^{\frac{mt}{\sqrt{2}}}mx\psi\partial_\psi - 2e^{\frac{mt}{\sqrt{2}}}x\partial_t, \\
X_{16}^2 &= \frac{2\sqrt{2}e^{-\frac{mt}{\sqrt{2}}}}{m}\partial_y + \sqrt{2}e^{\frac{mt}{\sqrt{2}}}my\psi\partial_\psi - 2e^{\frac{mt}{\sqrt{2}}}y\partial_t, \\
X_{17}^2 &= \frac{2\sqrt{2}e^{-\frac{mt}{\sqrt{2}}}}{m}\partial_z + \sqrt{2}e^{\frac{mt}{\sqrt{2}}}mz\psi\partial_\psi - 2e^{\frac{mt}{\sqrt{2}}}z\partial_t, \\
X_{18}^2 &= \frac{2e^{-\frac{mt}{\sqrt{2}}}(2+e^{\sqrt{2}mt}m^2(x^2+y^2+z^2))}{m^2}\partial_t - \frac{\sqrt{2}e^{-\frac{mt}{\sqrt{2}}}(-2+e^{\sqrt{2}mt}m^2(x^2+y^2+z^2))\psi}{m}\partial_\psi - \frac{4\sqrt{2}e^{-\frac{mt}{\sqrt{2}}}x}{m}\partial_x - \\
&\quad \frac{4\sqrt{2}e^{-\frac{mt}{\sqrt{2}}}y}{m}\partial_y - \frac{4\sqrt{2}e^{-\frac{mt}{\sqrt{2}}}z}{m}\partial_z,
\end{aligned}$$

where

$$-2e^{\sqrt{2}mt}m^2\mathcal{F}_1(t, x, y, z) + 2\mathcal{F}_{1zz} + 2\mathcal{F}_{1yy} + 2\mathcal{F}_{1xx} - 3\sqrt{2}e^{\sqrt{2}mt}m\mathcal{F}_{1t} - 2e^{\sqrt{2}mt}\mathcal{F}_{1tt} = 0.$$

(3) $H \neq 0, m^2 \neq 2H^2$

We obtain a 12-dimensional Lie algebra. Again, the symmetries X_1^1 to X_6^1 above, are common to this case, with the rest being,

$$\begin{aligned} X_7^3 &= -\partial_t + Hx\partial_x + Hy\partial_y + Hz\partial_z, \\ X_8^3 &= -2Hxy\partial_y - 2Hxz\partial_z + 2x\partial_t + \left(-\frac{e^{-2Ht}}{H} + H(-x^2 + y^2 + z^2)\right)\partial_x, \\ X_9^3 &= 2xy\partial_x - \frac{2y}{H}\partial_t + 2yz\partial_z + \left(\frac{e^{-2Ht}}{H^2} - x^2 + y^2 - z^2\right)\partial_y, \\ X_{10}^3 &= 2xz\partial_x - \frac{2z}{H}\partial_t + 2yz\partial_y + \left(\frac{e^{-2Ht}}{H^2} - x^2 - y^2 + z^2\right)\partial_z, \\ X_{11}^3 &= \psi\partial_\psi, \\ X_{12}^3 &= \mathcal{F}_1(t, x, y, z)\partial_\psi, \end{aligned}$$

where

$$-e^{2Ht}m^2\mathcal{F}_1(t, x, y, z) + \mathcal{F}_{1zz} + \mathcal{F}_{1yy} + \mathcal{F}_{1xx} - 3e^{2Ht}H\mathcal{F}_{1t} - e^{2Ht}\mathcal{F}_{1tt} = 0.$$

CASE II. $V(\psi) = \psi^4$. The Lie point symmetries contain the following subcases.

(1) $H \neq 0, m = -\sqrt{2}H$

This case shares the symmetries of CASE I - (1), with the exception of $X_8^1, X_{11}^1, X_{12}^1$.

Also,

$$\frac{2\sqrt{2}x}{m}\partial_t + 2xy\partial_y + 2xz\partial_z + \left(\frac{2e^{\sqrt{2}mt}}{m^2} + x^2 - y^2 - z^2\right)\partial_x$$

is a Lie point symmetry for this case. Therefore, we obtain a 16-dimensional Lie algebra of point symmetries.

(2) $H \neq 0, m = \sqrt{2}H$

Similarly, the symmetries of CASE I - (2) are common to this case, with the exception of $X_8^2, X_{11}^2, X_{12}^2$. Also,

$$\frac{-2\sqrt{2}x}{m}\partial_t + 2xy\partial_y + 2xz\partial_z + \left(\frac{2e^{-\sqrt{2}mt}}{m^2} + x^2 - y^2 - z^2 \right) \partial_x$$

is a Lie point symmetry for this case. Therefore, we obtain a 16-dimensional Lie algebra of point symmetries.

(3) $H \neq 0, m^2 \neq 2H^2$

This case yields the following Lie point symmetries

$$\begin{aligned} X_1 &= \partial_x, \\ X_2 &= \partial_y, \\ X_3 &= x\partial_y - y\partial_x, \\ X_4 &= \partial_z, \\ X_5 &= x\partial_z - z\partial_x, \\ X_6 &= y\partial_z - z\partial_y, \\ X_7 &= -\partial_t + Hx\partial_x + Hy\partial_y + Hz\partial_z, \\ X_8 &= \frac{-2x}{H}\partial_t + 2xy\partial_y + 2xz\partial_z + \left(\frac{e^{-2Ht}}{H^2} + x^2 - y^2 - z^2 \right) \partial_x, \\ X_9 &= 2xy\partial_x - \frac{2y}{H}\partial_t + 2yz\partial_z + \left(\frac{e^{-2Ht}}{H^2} - x^2 + y^2 - z^2 \right) \partial_y, \\ X_{10} &= 2xz\partial_x - \frac{2z}{H}\partial_t + 2yz\partial_z + \left(\frac{e^{-2Ht}}{H^2} - x^2 - y^2 + z^2 \right) \partial_z. \end{aligned}$$

For purposes of reduction in the next section, we present a section of the commutator table - see Table 2.1 - where $[A, B] = AB - BA$ is the Lie bracket of the vector fields (operators) A and B .

Table 2.1: Commutator Table

[.]	X_1	X_2	X_3	X_4	X_5	X_6	X_7	X_8	X_9
X_1	0	0	X_2	0	X_4	0	HX_1	$\frac{2X_7}{H}$	$-2X_3$
X_2	0	0	$-X_1$	0	0	X_4	HX_2	$2X_3$	$\frac{2X_7}{H}$
X_3	$-X_2$	X_1	0	0	$-X_6$	X_5	0	$-X_9$	X_8
X_4	0	0	0	0	$-X_1$	$-X_2$	HX_4	$2X_5$	$2X_6$
X_7	$-HX_1$	$-HX_2$	0	$-HX_4$	0	0	0	HX_8	HX_9

Remark. Other subcases of CASE I and II for the Klein-Gordon equation do exist. These are, $m = H = 0$ and $H = 0, m \neq 0$ for CASE I, and $m = H = 0$ and $H = 0, m = \pm \frac{\pi}{2}, m \neq 0$ in CASE II. However, these subcases set the Hubble constant $H = 0$, and therefore are not relevant to our study.

2.3.1 Symmetry reduction and exact solutions

As an illustration, we briefly show how the order of the (1+3) Gordon equation (23) with potential function $V = \psi^4$ can be reduced using a Lie symmetry subalgebra. Ultimately the equation with four independent variables is reduced to an ordinary differential equation. From the commutator table above, we have $[X_1, X_6] = 0$, $[X_6, X_7] = 0$, and $[X_1, X_7] = HX_1$, so that $\langle X_1, X_6, X_7 \rangle$ form a subalgebra. We

begin reducing (23) with X_6 . The characteristic equations are

$$\frac{dx}{0} = \frac{dt}{0} = \frac{dy}{-z} = \frac{dz}{y} = \frac{d\psi}{0}.$$

Integrating yields $\alpha = \frac{1}{2}(y^2 + z^2)$ and (23) is reduced to

$$\psi_{tt} + 3H\psi_t - e^{-2Ht}(\psi_{xx} + 2\alpha\psi_{\alpha\alpha} + 2\psi_{\alpha}) + m^2\psi + 4\psi^3 = 0 \quad (26)$$

with $\psi = \psi(x, t, \alpha)$.

Suppose we reduce (26) with the symmetry X_1 . This yields the reduced equation

$$\psi_{tt} + 3H\psi_t - 2e^{-2Ht}(\alpha\psi_{\alpha\alpha} + \psi_{\alpha}) + m^2\psi + 4\psi^3 = 0 \quad (27)$$

with $\psi = \psi(t, \alpha)$.

Now in order to reduce (27), we map X_7 onto \bar{X}_7 , where

$$\bar{X}_7 = -\partial_t + Hx\partial_x + 2H\alpha\partial_{\alpha}.$$

The characteristic equations are then

$$\frac{dx}{Hx} = \frac{dt}{-1} = \frac{d\alpha}{2H\alpha} = \frac{d\psi}{0}.$$

By integrating, we obtain $\beta = \alpha e^{2Ht}$ and (27) reduces to the ordinary differential equation

$$\psi_{\beta}(10H^2\beta - 2) + \psi_{\beta\beta}(4H^2\beta^2 - 2\beta) + m^2\psi + 4\psi^3 = 0, \quad (28)$$

which may be solved using an alternative analytical approach or some numerical technique.

Remark. For a constant potential V , (23) is a Klein-Gordon equation reduced to, using the same reduction from above,

$$\psi_\beta(10H^2\beta - 2) + \psi_{\beta\beta}(4H^2\beta^2 - 2\beta) + m^2\psi = 0, \quad (29)$$

which has a solution in terms of special functions. That is,

$$\begin{aligned} \psi(\beta) = & C_1 {}_2F_1 \left[\frac{3}{4} - \frac{\sqrt{9H^4 - 4H^2m^2}}{4H^2}, \frac{3}{4} + \frac{\sqrt{9H^4 - 4H^2m^2}}{4H^2}, 1, 2H^2\beta \right] + \\ & C_2 \text{MeijerG} \left[\left\{ \left\{ \right\}, \left\{ \frac{H^2 + \sqrt{9H^4 - 4H^2m^2}}{4H^2}, \frac{1}{4} - \frac{\sqrt{9H^4 - 4H^2m^2}}{4H^2} \right\} \right\}, \left\{ \{0, 0\}, \left\{ \right\} \right\}, 2H^2\beta \right], \end{aligned} \quad (30)$$

where the ${}_2F_1[a, b, c, z]$ is the regularised Hypergeometric function ${}_2F_1(a, b; c; z)/\Gamma(c)$, MeijerG $[\{\{a_1, \dots, a_n\}, \{a_{n+1}, \dots, a_p\}\}, \{\{b_1, \dots, b_m\}, \{b_{m+1}, \dots, b_q\}\}, z]$ is the Meijer G function

$$G_{pq}^{mn} \left(z \mid \begin{matrix} a_1, \dots, a_p \\ b_1, \dots, b_q \end{matrix} \right),$$

and C_1, C_2 are arbitrary constants.

Thus, the respective Klein-Gordon equation has this exact or closed form solution invariant under translation in x , rotation in yz and time translation combined with scaling. A number of other invariant solutions may be obtained via appropriate subalgebras.

2.4 Special cases of $V(\psi)$ - Noether approach

In this section, we briefly discuss the wave/Klein-Gordon equations in the context of some special potentials. These could be studied as above but, to present an alternative approach, we consider Noether symmetries [8]. In short, a symmetry generator X is a Noether symmetry if it leaves invariant the action integral that gives rise to an Euler-Lagrange equation. By Noether's theorem, every Noether symmetry

gives rise to a conservation law and is itself a Lie symmetry of the equation. Details of the relevant equations and formulae can be found in, inter alia, [8].

A Lagrangian for (23) is given by

$$L = e^{nHt} \left[j(\psi) + \frac{1}{2}e^{-2Ht}\psi_i^2 - \frac{1}{2}\psi_t^2 \right],$$

where $j(\psi) = \frac{1}{2}m^2\psi^2 + V(\psi)$, and as before, $m = 0$ implies the wave equation and $m \neq 0$ relates to the Klein-Gordon equation.

A special feature of Noether symmetries are their relationships with conservation laws. A conserved vector of (23) is a vector $(\Phi^x, \Phi^y, \Phi^z, \Phi^t)$ such that

$$D_x\Phi^x + D_y\Phi^y + D_z\Phi^z + D_t\Phi^t = Q(\psi_{tt} + nH\psi_t - e^{-2Ht}\Delta\psi + m^2\psi + V'(\psi)),$$

for some differential function Q and D_i ($i = x, y, z, t$) is the total derivative with respect to the i -th variable.

The conserved/closed form $D_x\Phi^x + D_y\Phi^y + D_z\Phi^z + D_t\Phi^t = 0$ along the solutions of (23) is referred to as a *conservation law*.

(i) *CASE III*. $V(\psi) = \psi^2$ - mass term.

(a) The Noether symmetries of the wave equation are

$$\begin{aligned} X_1 &= \partial_x, \\ X_2 &= \partial_z, \\ X_3 &= \partial_y, \\ X_4 &= -z\partial_x + x\partial_z, \\ X_5 &= x\partial_x + y\partial_y + z\partial_z - \frac{1}{h}\partial_t, \\ X_6 &= zx\partial_x + yz\partial_y + \frac{e^{-2ht} - h^2y^2 + h^2z^2 - h^2x^2}{2h^2}\partial_z - \frac{z}{h}\partial_t, \\ X_7 &= -y\partial_x + x\partial_y, \\ X_8 &= z\partial_y - y\partial_z, \end{aligned}$$

$$\begin{aligned}
X_9 &= zx\partial_z + yx\partial_y + \frac{e^{-2ht} - h^2y^2 - h^2z^2 + h^2x^2}{2h^2}\partial_z - \frac{x}{h}\partial_t, \\
X_{10} &= 2yh^2z\partial_z + 2yh^2x\partial_x + (e^{-2ht} + h^2y^2 - h^2z^2 - h^2x^2)\partial_y - 2yh\partial_t.
\end{aligned}$$

(b) The Noether symmetries of the Klein-Gordon equation are

$$\begin{aligned}
X_1 &= \partial_x, \\
X_2 &= \partial_z, \\
X_3 &= \partial_y, \\
X_4 &= z\partial_x - x\partial_z, \\
X_5 &= x\partial_x + y\partial_y + z\partial_z - \frac{1}{h}\partial_t, \\
X_6 &= zx\partial_x + yz\partial_y + \frac{e^{-2ht} - h^2y^2 + h^2z^2 - h^2x^2}{2h^2}\partial_z - \frac{z}{h}\partial_t, \\
X_7 &= y\partial_x - x\partial_y, \\
X_8 &= -z\partial_y + y\partial_z, \\
X_9 &= zy\partial_z + yx\partial_x + \frac{e^{-2ht} + h^2y^2 - h^2z^2 - h^2x^2}{2h^2}\partial_y - \frac{y}{h}\partial_t, \\
X_{10} &= 2h^2zx\partial_z + 2h^2yx\partial_y + (e^{-2ht} - h^2y^2 - h^2z^2 + h^2x^2)\partial_x - 2xh\partial_t.
\end{aligned}$$

As an example, the conserved vector corresponding to the angular momentum in the xy coordinates (corresponding to the generator $X_7 = y\partial_x - x\partial_y$) is

$$\begin{aligned}
\Phi^x &= -\frac{1}{2}ye^{3ht}m^2\psi^2 - ye^{3ht}\psi^2 + \frac{1}{2}ye^{ht}\psi_x^2 - \frac{1}{2}\psi_y^2ye^{ht} - \frac{1}{2}\psi_z^2ye^{ht} + \frac{1}{2}\psi_t^2ye^{3ht} \\
&\quad - \psi_y\psi_xxe^{ht}, \\
\Phi^y &= \frac{1}{2}xe^{3ht}m^2\psi^2 + xe^{3ht}\psi^2 + \frac{1}{2}xe^{ht}\psi_x^2 - \frac{1}{2}\psi_y^2xe^{ht} + \frac{1}{2}\psi_z^2xe^{ht} - \frac{1}{2}\psi_t^2xe^{3ht} \\
&\quad + \psi_y\psi_xye^{ht}, \\
\Phi^z &= -(x\psi_y - y\psi_x)\psi_z e^{ht}, \\
\Phi^t &= (x\psi_y - y\psi_x)e^{3ht}\psi_t.
\end{aligned}$$

(ii) *CASE IV.* $V(\psi) = (\psi^2 - k)^2$ - Higg's potential.

(a) The Noether symmetries of the wave equation are

$$\begin{aligned}
X_1 &= \partial_x, \\
X_2 &= \partial_z, \\
X_3 &= \partial_y, \\
X_4 &= -z\partial_x + x\partial_z, \\
X_5 &= -hx\partial_x - hy\partial_y - hz\partial_z + \partial_t, \\
X_6 &= -hzx\partial_x - hyz\partial_y - \frac{e^{-2ht} - h^2y^2 + h^2z^2 - h^2x^2}{2h}\partial_z + z\partial_t, \\
X_7 &= -y\partial_x + x\partial_y, \\
X_8 &= z\partial_y - y\partial_z, \\
X_9 &= -zhx\partial_z - hys\partial_y - \frac{e^{-2ht} - h^2y^2 - h^2z^2 + h^2x^2}{2h^2}\partial_x + x\partial_t, \\
X_{10} &= -hzy\partial_z - hys\partial_x - \frac{e^{-2ht} + h^2y^2 - h^2z^2 - h^2x^2}{2h}\partial_y + y\partial_t.
\end{aligned}$$

(b) The Noether symmetries of the Klein-Gordon equation are

$$\begin{aligned}
X_1 &= \partial_x, \\
X_2 &= \partial_z, \\
X_3 &= \partial_y, \\
X_4 &= -z\partial_x + x\partial_z, \\
X_5 &= x\partial_x + y\partial_y + z\partial_z - \frac{1}{h}\partial_t, \\
X_6 &= xy\partial_x + yz\partial_z + \frac{e^{-2ht} + h^2y^2 - h^2z^2 - h^2x^2}{2h^2}\partial_y - \frac{y}{h}\partial_t, \\
X_7 &= y\partial_x - x\partial_y, \\
X_8 &= -z\partial_y + y\partial_z, \\
X_9 &= xy\partial_y + xz\partial_z + \frac{e^{-2ht} - h^2y^2 - h^2z^2 + h^2x^2}{2h^2}\partial_x - \frac{x}{h}\partial_t, \\
X_{10} &= 2zh^2x\partial_x + 2yh^2z\partial_y + (e^{-2ht} - h^2y^2 + h^2z^2 - h^2x^2)\partial_z - 2zh\partial_t.
\end{aligned}$$

As an example, the conserved vector corresponding to the angular momentum in

the xy coordinates (corresponding to the generator $X_7 = y\partial_x - x\partial_y$) is

$$\begin{aligned}
\Phi^x &= -\frac{1}{2}ye^{3ht}m^2\psi^2 - ye^{3ht}\psi^4 + 2ye^{3ht}\psi^2k - ye^{3ht}k^2 + \frac{1}{2}ye^{ht}\psi_x^2 - \frac{1}{2}\psi_y^2ye^{ht} \\
&\quad - \frac{1}{2}\psi_z^2ye^{ht} + \frac{1}{2}\psi_t^2ye^{3ht} - \psi_y\psi_xxe^{ht}, \\
\Phi^y &= \frac{1}{2}xe^{3ht}m^2\psi^2 + xe^{3ht}\psi^4 - 2xe^{3ht}\psi^2k + xe^{3ht}k^2 + \frac{1}{2}xe^{ht}\psi_x^2 - \frac{1}{2}\psi_y^2xe^{ht} \\
&\quad + \frac{1}{2}\psi_z^2xe^{ht} - \frac{1}{2}\psi_t^2xe^{3ht} + \psi_y\psi_xye^{ht}, \\
\Phi^z &= -(x\psi_y - y\psi_x)\psi_z e^{ht}, \\
\Phi^t &= (x\psi_y - y\psi_x)e^{3ht}\psi_t.
\end{aligned}$$

2.5 Conclusion

Using the Lie symmetry generators (one parameter Lie groups of transformations), we classified and reduced the underlying equations and showed (in a specific case) how this process leads to exact solutions by quadratures. One may also obtain the conserved quantities corresponding to each symmetry listed above. A variational technique, such as Noether's theorem, could also be applied to the wave and Klein-Gordon equation in sections 2.2 and 2.3. Here, a Lagrangian would be required; this was demonstrated in the final subsection using some special potentials.

In the cases discussed, we find 'twelve' or 'eighteen' dimensional Lie symmetry groups. Interestingly, all the symmetry groups contain a 'six' dimensional Lie symmetry subgroup. This six dimensional Lie symmetry subgroup consists of 'three' linear momenta conservation along x , y & z directions, and three rotations in xy , yz and xz directions. As such these symmetries form a subgroup of the Killing group admitted by the de Sitter spacetime. Not all of the symmetries that are listed lead to physical conservation laws. However, symmetries that do not lead to conservation laws are as useful in application, for example, to reduce the underlying wave or Klein-Gordon equation.

Chapter 3

The Milne Spacetime

3.1 Introduction

Recently, Noether symmetries of the Euler-Lagrange equations on the Milne metric have attracted much interest [44]. In [45], the Noether symmetries were found and a discussion of the results were given by a comparison of Noether symmetries on the Milne metric with those of other conventional symmetries of the same spacetime. Concerning the pure wave equation (homogeneous), it is a priori clear that it will admit a maximal Noether symmetry group on a flat manifold. In that spirit, the work of [45] gives limited information and needs further investigation. With this point in mind, we extend the work [45] by studying a Klein-Gordon [13] equation on the Milne metric and see how Noether symmetry structures change when classical wave equations are coupled with an inhomogeneous term. For completeness, we also investigate the existence of higher-order variational symmetries of a projection of the Klein-Gordon equation using the multiplier approach.

Our analysis takes the following form. In section 3.2 we derive Lie point symmetries of some Gordon-type equations and illustrate the reduction of a wave equation on the Milne manifold. In section 3.3, we determine the Noether point symmetries of the Klein-Gordon equation and construct the associated conserved densities. Lastly, in section 3.4, we list some higher-order symmetries and conservation laws of a projected Klein-Gordon equation.

Consider the Milne metric [44]

$$ds^2 = -dt^2 + t^2(dx^2 + e^{2x}(dy^2 + dz^2)) \quad (31)$$

which represents an empty universe and is of interest in relativity for being a special case of a well known Friedmann-Lemaître-Robertson-Walker metric [13, 44]. The Klein-Gordon equation [13] on (31) is obtained by

$$\square u = \frac{1}{\sqrt{|-g|}} \frac{\partial}{\partial x^i} \left(\sqrt{|-g|} g^{ij} \frac{\partial}{\partial x^i} u \right) = k(u), \quad (32)$$

and takes the form

$$u_{xx} - t^2 u_{tt} + e^{-2x} u_{yy} + e^{-2x} u_{zz} - 3t u_t + 2u_x - t^2 k(u) = 0. \quad (33)$$

3.2 Lie symmetries of Gordon-type equations

In order to find the Lie point symmetries of the above Gordon-type equation (33) we restrict $k(u)$ to some special cases. These cases are assumed by keeping in mind the fact that we allow the inhomogeneous term, $k(u)$, to be taken as $\sin(u)$ and some powers of u . The criteria that yields the Lie point symmetry is given by the invariance condition [4]

$$X [u_{xx} - t^2 u_{tt} + e^{-2x} u_{yy} + e^{-2x} u_{zz} - 3t u_t + 2u_x - t^2 k(u)] \Big|_{Eq.(33)=0} = 0, \quad (34)$$

where X would be the prolonged symmetry generator in the jet space. Thus, the invariance of differential equations (33) leads to the Lie point symmetries possessed by (33). The procedure for finding Lie point symmetries is well known [4] and therefore will be given without derivations. It turns out, from the symmetry study, that some special polynomial cases of $k(u)$ arise. Also, in line with the literature, we consider the sine-Gordon equation. Thus, we study the four cases for $k(u)$ in (33) given by

- (i) $k(u) = \sin(u)$,
- (ii) $k(u) = u$,
- (iii) $k(u) = u^3$,
- (iv) $k(u) = u^n, n \neq 0, 1, 3$.

Case (i) The case $k(u) = \sin(u)$ gives the sine-Gordon equation. Following the symmetry criterion, we find that equation (34) in this case admits the following ten Lie point symmetries,

$$\begin{aligned}
X_1 &= \frac{e^x}{t} \partial_x - e^x \partial_t, \\
X_2 &= \partial_y, \\
X_3 &= \frac{e^{-x}}{t} \partial_y - e^x y \partial_t + \frac{e^x y}{t} \partial_x, \\
X_4 &= \partial_z, \\
X_5 &= \frac{e^{-x}}{t} \partial_z - e^x z \partial_t + \frac{e^x z}{t} \partial_x, \\
X_6 &= y \partial_z - z \partial_y, \\
X_7 &= -\partial_x + y \partial_y + z \partial_z, \\
X_8 &= \frac{2e^{-x} y}{t} \partial_y + \frac{2e^{-x} z}{t} \partial_z + e^{-x} (-1 - e^{2x} (y^2 + z^2)) \partial_t + \frac{e^{-x} (-1 + e^{2x} (y^2 + z^2))}{t} \partial_x, \\
X_9 &= 2y \partial_x - 2yz \partial_z + (e^{-2x} - y^2 + z^2) \partial_y, \\
X_{10} &= -2yz \partial_y + 2z \partial_x + (e^{-2x} + y^2 - z^2) \partial_z.
\end{aligned}$$

Case (ii) When $k(u) = u$, we have a Klein-Gordon equation. Equation (34) in this case admits thirteen Lie point symmetries given by,

$$\begin{aligned}
X_1 &= u\partial_u, \\
X_2 &= \mathcal{F}_1(x, y, z, t)\partial_u, \\
X_3 &= \frac{e^x}{t}\partial_x - e^x\partial_t, \\
X_4 &= \partial_y, \\
X_5 &= \frac{e^{-x}}{t}\partial_y - e^xy\partial_t + \frac{e^xy}{t}\partial_x, \\
X_6 &= y\partial_z - z\partial_y, \\
X_7 &= -\partial_x + y\partial_y + z\partial_z, \\
X_8 &= \partial_z, \\
X_9 &= \frac{e^{-x}}{t}\partial_z - e^xz\partial_t + \frac{e^xz}{t}\partial_x, \\
X_{10} &= -2\partial_x + 2y\partial_y + 2z\partial_z + u\partial_u, \\
X_{11} &= \frac{2e^{-x}y}{t}\partial_y + \frac{2e^{-x}z}{t}\partial_z + e^{-x}(-1 - e^{2x}(y^2 + z^2))\partial_t + \frac{e^{-x}(-1 + e^{2x}(y^2 + z^2))}{t}\partial_x, \\
X_{12} &= 2y\partial_x - 2yz\partial_z + (e^{-2x} - y^2 + z^2)\partial_y, \\
X_{13} &= -2yz\partial_y + 2z\partial_x + (e^{-2x} + y^2 - z^2)\partial_z,
\end{aligned}$$

where

$$e^{2x}t^2\mathcal{F}_1(t, x, y, z) - \mathcal{F}_{1,zz} - \mathcal{F}_{1,yy} - 2e^{2x}\mathcal{F}_{1,x} - e^{2x}\mathcal{F}_{1,xx} + 3e^{2x}t\mathcal{F}_{1,t} + e^{2x}t^2\mathcal{F}_{1,tt} = 0.$$

Case (iii) In the case $k(u) = u^3$, the (Gordon-type) equation (34) yields a set of fifteen Lie point symmetries, namely,

$$\begin{aligned}
X_1 &= t\partial_t - u\partial_u, \\
X_2 &= -2e^xtu\partial_u + e^x(1 + t^2)\partial_t + \frac{e^x(-1+t^2)}{t}\partial_x, \\
X_3 &= -2e^xtu\partial_u + e^x(-1 + t^2)\partial_t + \frac{e^x(1+t^2)}{t}\partial_x, \\
X_4 &= \partial_y, \\
X_5 &= -2e^xtyu\partial_u + \frac{e^{-x}(-1+t^2)}{t}\partial_y + e^x(1 + t^2)y\partial_t + \frac{e^x(-1+t^2)y}{t}\partial_x,
\end{aligned}$$

$$\begin{aligned}
X_6 &= y\partial_z - z\partial_y, \\
X_7 &= -\partial_x + y\partial_y + z\partial_z, \\
X_8 &= -2e^x t y u \partial_u + \frac{e^{-x}(1+t^2)}{t} \partial_y + e^x(-1+t^2)y\partial_t + \frac{e^x(1+t^2)y}{t} \partial_x, \\
X_9 &= \partial_z, \\
X_{10} &= 2e^x t z u \partial_u - \frac{e^{-x}(1+t^2)}{t} \partial_z - e^x(-1+t^2)z\partial_t - \frac{e^x(1+t^2)z}{t} \partial_x, \\
X_{11} &= -2e^x t z u \partial_u + \frac{e^{-x}(-1+t^2)}{t} \partial_z + e^x(1+t^2)z\partial_t + \frac{e^x(-1+t^2)z}{t} \partial_x, \\
X_{12} &= -2y\partial_x + 2yz\partial_z + (-e^{-2x} + y^2 - z^2)\partial_y, \\
X_{13} &= \frac{2e^{-x}(-1+t^2)y}{t} \partial_y + \frac{2e^{-x}(-1+t^2)z}{t} \partial_z - 2e^{-x} t u (1 + e^{2x}(y^2 + z^2)) \partial_u + \\
&\quad e^{-x}(1+t^2)(1 + e^{2x}(y^2 + z^2)) \partial_t + \frac{e^{-x}(-1+t^2)(-1+e^{2x}(y^2+z^2))}{t} \partial_x, \\
X_{14} &= \frac{2e^{-x}(1+t^2)y}{t} \partial_y + \frac{2e^{-x}(1+t^2)z}{t} \partial_z - 2e^{-x} t u (1 + e^{2x}(y^2 + z^2)) \partial_u + \\
&\quad e^{-x}(-1+t^2)(1 + e^{2x}(y^2 + z^2)) \partial_t + \frac{e^{-x}(1+t^2)(-1+e^{2x}(y^2+z^2))}{t} \partial_x, \\
X_{15} &= 2yz\partial_y - 2z\partial_x + (-e^{-2x} - y^2 + z^2)\partial_z.
\end{aligned}$$

Case (iv) For $k(u) = u^n, n \neq 0, 1, 3$, the general polynomial Gordon-type equation (34) admits eleven Lie point symmetries given by,

$$\begin{aligned}
X_1 &= \frac{2u}{-3+n} \partial_u + \frac{t-nt}{-3+n} \partial_t, \\
X_2 &= \frac{e^x}{t} \partial_x - e^x \partial_t, \\
X_3 &= \partial_y, \\
X_4 &= \frac{e^{-x}}{t} \partial_y - e^x y \partial_t + \frac{e^x y}{t} \partial_x, \\
X_5 &= \partial_z, \\
X_6 &= y\partial_z - z\partial_y, \\
X_7 &= -\partial_x + y\partial_y + z\partial_z, \\
X_8 &= \frac{e^{-x}}{t} \partial_z - e^x z \partial_t + \frac{e^x z}{t} \partial_x, \\
X_9 &= \frac{2e^{-x}y}{t} \partial_y + \frac{2e^{-x}z}{t} \partial_z + e^{-x}(-1 - e^{2x}(y^2 + z^2)) \partial_t + \frac{e^{-x}(-1+e^{2x}(y^2+z^2))}{t} \partial_x, \\
X_{10} &= -2y\partial_x + 2yz\partial_z + (-e^{-2x} + y^2 - z^2)\partial_y, \\
X_{11} &= 2yz\partial_y - 2z\partial_x + (-e^{-2x} - y^2 + z^2)\partial_z.
\end{aligned}$$

3.2.1 Symmetry reductions

We demonstrate the reduction of the (1+3) dimensional wave equation (33). The equation with four independent variables is reduced to a partial differential equation that has two independent variables. The reduced equation may then be analysed further using another Lie symmetry reduction or an appropriate alternative method. Since $[X_6, X_7] = 0$, where X_6 and X_7 appear as Lie symmetries in all the above cases, we may begin reducing with either X_6 or X_7 . Suppose we reduce (33) by $X_6 = y\partial_z - z\partial_y$. The characteristic equations are

$$\frac{dx}{0} = \frac{dt}{0} = \frac{dy}{-z} = \frac{dz}{y} = \frac{du}{0}.$$

Integrating yields $\alpha = y^2 + z^2$ and (33) is reduced to

$$\frac{1}{t^2}u_{xx} - u_{tt} + \frac{2}{t^2}e^{-2x}(\alpha u_{\alpha\alpha} + u_{\alpha}) - \frac{3}{t}u_t + \frac{2}{t^2}u_x - k(u) = 0 \quad (35)$$

with $u = u(x, t, \alpha)$.

If we then reduce (35) by $X_7 = -\partial_x + y\partial_y + z\partial_z$, we obtain the transformation $\bar{X} = -\partial_x + 2\alpha\partial_{\alpha}$. We now have the characteristic equations,

$$\frac{dt}{0} = \frac{dx}{-1} = \frac{d\alpha}{2\alpha} = \frac{du}{0}.$$

By integrating, we obtain $\beta = \ln \alpha + 2x$ and (35) reduces to

$$\frac{2}{t^2}u_{\beta\beta}(2 + e^{-\beta}) - u_{tt} + \frac{4}{t^2}u_{\beta} - \frac{3}{t}u_t - k(u) = 0 \quad (36)$$

with $u = u(t, \beta)$.

Equation (36) may be further analysed or reduced using the underlying symmetries. It turns out that the Lie point symmetries are cumbersome and involve special

functions such as Bessel functions for the case $k(u) = u$.

For $k(u) = u^3$, (36) admits one symmetry,

$$t\partial_t - u\partial_u.$$

For $k(u) = u^4$, the symmetries of (36) are

$$X_1 = \frac{3}{4}t\partial_t - \frac{1}{2}u\partial_u, \quad X_2 = 4t^2(1 + 2e^\beta)\partial_\beta + t^3(1 + 4e^\beta)\partial_t - 2t^2u(1 + 4e^\beta)\partial_u.$$

Using X_2 , (36) reduces to the ordinary differential equation

$$\gamma^4 F_{\gamma\gamma} + \gamma F_\gamma + 4F - 8\gamma^2 F^4 = 0, \quad (37)$$

where $\gamma = \frac{te^{-\frac{\beta}{4}}}{(1 + 2e^\beta)^{\frac{1}{4}}}$ and $F = ue^{\frac{\beta}{2}}(1 + 2e^\beta)^{\frac{1}{2}}$. It turns out that (37) admits the Lie point symmetry $G = -\frac{3}{2}\beta\partial_\beta + F\partial_F$ which leads to the first-order ordinary differential equation

$$q_p = \frac{2q + 24q^{\frac{2}{3}}p^{\frac{4}{3}} - 12q^{\frac{2}{3}}p^{\frac{1}{3}}}{2p + 3q^{\frac{1}{3}}p^{\frac{2}{3}}}, \quad (38)$$

where $p = \gamma^2 F^3$ and $q = \gamma^5 F^{\nu 3}$.

There are no symmetries for $k(u) = u^n$, $n \neq 0, 1, 3, 4$ and $k(u) = \sin u$ in (36).

Also, one may consider reduction by studying the underlying conservation laws. This would require methods other than the variational one, i.e., Noether's theorem, since (36) is not variational.

For the Klein-Gordon case $k(u) = u$, it can be shown, for example, that a conserved vector of (36) is (Φ^β, Φ^t) , where

$$\begin{aligned} \Phi^\beta &= 2(1 + 2e^\beta)\text{BesselJ}(1, t)u_\beta, \\ \Phi^t &= \frac{1}{2}e^\beta t[(t\text{BesselJ}(0, t) - 2\text{BesselJ}(1, t) \\ &\quad - t\text{BesselJ}(2, t))u - 2t\text{BesselJ}(1, t)u_t], \end{aligned}$$

such that $D_\beta\Phi^\beta + D_t\Phi^t = 0$ along the solutions of (36) and where BesselJ is the Bessel function of the first kind.

For $k(u) = u^3$ in (36), the components of the conserved vector are

$$\begin{aligned}\Phi^\beta &= (1 + 2e^\beta)t^2[u_t u_\beta - u u_{\beta t}], \\ \Phi^t &= -\frac{1}{4}t^2[e^\beta t^2 u^4 + 2e^\beta t^2 u_t^2 + 4u(e^\beta t u_t \\ &\quad - 2e^\beta u_\beta - (1 + 2e^\beta)u_{\beta\beta})].\end{aligned}$$

Similarly, for $k(u) = u^4$, the components of the conserved vector are

$$\begin{aligned}\Phi^\beta &= -\frac{1}{5}(1 + 2e^\beta)t^3(40e^\beta u^2 + 4e^\beta t^2 u^5 \\ &\quad - 5u_\beta((1 + 4e^\beta)t u_t + 4(1 + 2e^\beta)u_\beta) \\ &\quad + 5tu(10e^\beta u_t + 2e^\beta t u_{tt} + (1 + 4e^\beta)u_{\beta t})), \\ \Phi^t &= -t^4(-2e^\beta(1 + 4e^\beta)u^2 + \frac{1}{5}e^\beta(1 + 4e^\beta)t^2 u^5 \\ &\quad + \frac{1}{2}e^\beta t u_t((1 + 4e^\beta)t u_t + 4(1 + 2e^\beta)u_\beta) \\ &\quad - u(2e^\beta(3 + 8e^\beta)u_\beta + (1 + 2e^\beta)(2e^\beta t u_{\beta t} \\ &\quad + (1 + 4e^\beta)u_{\beta\beta}))).\end{aligned}$$

The cases $k(u) = \sin u$ and $k(u) = u^n$, $n \neq 1, 3, 4$, do not yield any conserved vectors.

3.2.2 Exact solutions and boundary conditions

We reduce (33) by first using the symmetry $X = \partial_y$ to obtain

$$\frac{1}{t^2}u_{xx} - u_{tt} + \frac{1}{t^2}e^{-2x}u_{zz} - \frac{3}{t}u_t + \frac{2}{t^2}u_x - k(u) = 0, \quad (39)$$

$$u = u(x, z, t), \quad u(x, 0, t) = 0, \quad u(x, 1, t) = 1.$$

We reduce (39) further using the symmetry $X = \frac{e^x}{t}\partial_x - e^x\partial_t$. The characteristic equations are

$$\frac{tdx}{e^x} = \frac{dt}{-e^x} = \frac{dz}{0} = \frac{du}{0}.$$

Integrating yields $\tilde{t} = \frac{1}{t}e^{-x}$ and (39) is reduced to

$$\frac{1}{\tilde{t}^2}u_{zz} - k(u) = 0, \quad (40)$$

where $u(z, \tilde{t})$ and boundary conditions transform to

$$u(0, \tilde{t}) = 0, \quad u(1, \tilde{t}) = 1.$$

If $k(u) = u$, as in the Klein-Gordon case, then the general solution to (40) is

$$u(z, \tilde{t}) = e^{\tilde{t}z}C_1(\tilde{t}) + e^{-\tilde{t}z}C_2(\tilde{t}). \quad (41)$$

We plot the function \tilde{t} over different ranges, Figure 3.1: $\{x, -50, 50\}, \{t, 1, 10\}$ and Figure 3.2: $\{x, -10, 10\}, \{t, 1, 10\}$. When $t \rightarrow \pm\infty$, $\tilde{t} \rightarrow 0$, and when $t \rightarrow 0$, \tilde{t} becomes large.

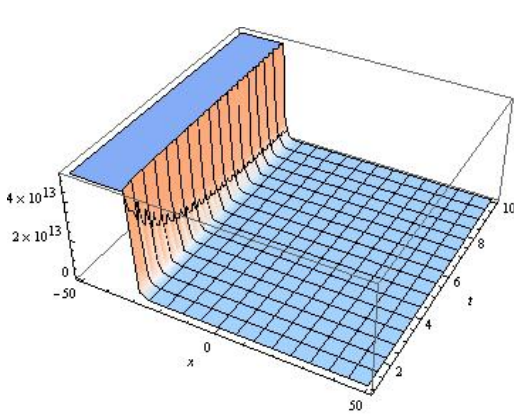

Figure 3.1: $\tilde{t} = \frac{1}{t}e^{-x}$

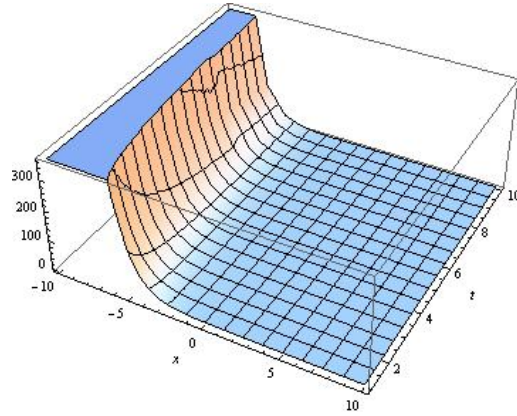

Figure 3.2: $\tilde{t} = \frac{1}{t}e^{-x}$

Keeping this in mind, we plot $u(z, \tilde{t})$ from (41) in Figure 3.3: $\{\tilde{t}, 0, 10\}, \{z, -5, 5\}$ and Figure 3.4: $\{\tilde{t}, 0, 10\}, \{z, -5, 5\}$, choosing particular C_1 's and C_2 's.

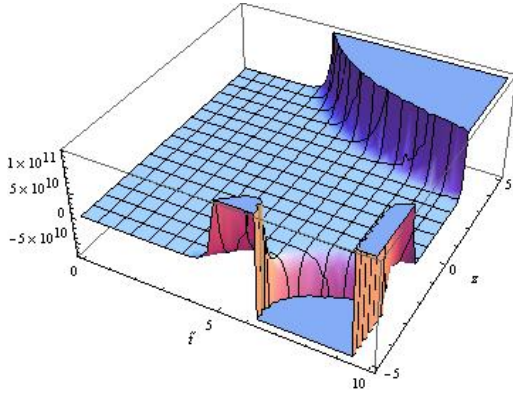

Figure 3.3: $C_1=100 \tilde{t}^2, C_2=-2 \sin(\tilde{t})$

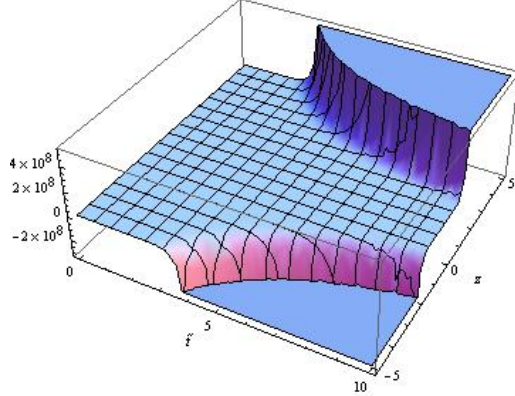

Figure 3.4: $C_1 = 100, C_2 = -2$

If we impose the boundary conditions on (41), the solution of $u(z, \tilde{t})$ may be expressed in terms of the hyperbolic sine function, namely,

$$u(z, \tilde{t}) = \frac{1}{2\sinh(\tilde{t})} e^{\tilde{t}z} - \frac{1}{2\sinh(\tilde{t})} e^{-\tilde{t}z}.$$

The graph of this solution, for the range $\{\tilde{t}, 0, 10\}, \{z, -5, 5\}$, is given by Figure 3.5.

Remark. For the sine-Gordon case, with $k(u) = \sin(u)$ in (40), we obtain

$$u(z, \tilde{t}) = \pm 2 \text{JacobiAmplitude} \left[\frac{1}{2} \sqrt{-(2\tilde{t}^2 - D_1(\tilde{t})) (z + D_2(\tilde{t}))^2}, -\frac{4\tilde{t}^2}{-2\tilde{t}^2 + D_1(\tilde{t})} \right],$$

where $\text{JacobiAmplitude}[v, m]$ refers to the amplitude $am(v | m)$ for Jacobi elliptic functions.

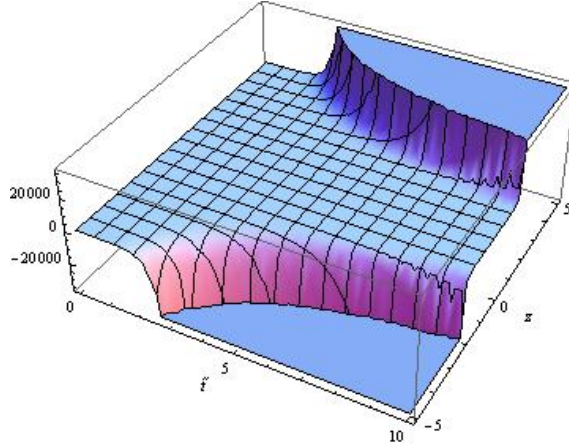

Figure 3.5: $u(z, \tilde{t}) = \frac{1}{2\sinh(\tilde{t})}e^{\tilde{t}z} - \frac{1}{2\sinh(\tilde{t})}e^{-\tilde{t}z}$

3.3 Noether symmetries of a Klein-Gordon equation

Consider the wave equation (33) with $k(u) = u$ (Klein-Gordon), which has the Lagrangian,

$$L = \frac{1}{2}t^3 e^{2x} u^2 + \frac{1}{2}t e^{2x} u_x^2 + \frac{1}{2}t u_y^2 + \frac{1}{2}t u_z^2 - \frac{1}{2}t^3 e^{2x} u_t^2. \quad (42)$$

Let

$$X = \xi(t, x, y, z, u)\partial_x + \tau(t, x, y, z, u)\partial_t + \eta(t, x, y, z, u)\partial_y + \gamma(t, x, y, z, u)\partial_z + \phi(t, x, y, z, u)\partial_u$$

be a Noether point operator that satisfies (14) with gauge vector f_i ($i = 1, 2, 3, 4$) dependent on (t, x, y, z, u) . This becomes, for the Lagrangian given by (42),

$$XL + L[D_t\tau + D_x\xi + D_y\eta + D_z\gamma] = D_t f_1 + D_x f_2 + D_y f_3 + D_z f_4.$$

Separation by derivatives of u yields the following overdetermined system

$$\begin{aligned}
u_t^3 & : \tau_u = 0, \\
u_x^3 & : \xi_u = 0, \\
u_y^3 & : \eta_u = 0, \\
u_z^3 & : \gamma_u = 0, \\
u_t^2 & : -e^{2x}t^3\xi - \frac{3}{2}e^{2x}t^2\tau - \frac{1}{2}e^{2x}t^3\gamma_z - \frac{1}{2}e^{2x}t^3\eta_y - \frac{1}{2}e^{2x}t^3\xi_x + \frac{1}{2}e^{2x}t^3\tau_t \\
& \quad - e^{2x}t^3\phi_u = 0, \\
u_x^2 & : e^{2x}t\xi + \frac{1}{2}e^{2x}\tau + \frac{1}{2}e^{2x}t\gamma_z + \frac{1}{2}e^{2x}t\eta_y - \frac{1}{2}e^{2x}t\xi_x + \frac{1}{2}e^{2x}t\tau_t + e^{2x}t\phi_u = 0, \\
u_y^2 & : \frac{1}{2}\tau + \frac{1}{2}t\gamma_z - \frac{1}{2}t\eta_y + \frac{1}{2}t\xi_x + \frac{1}{2}t\tau_t + t\phi_u = 0, \\
u_z^2 & : \frac{1}{2}\tau - \frac{1}{2}t\gamma_z + \frac{1}{2}t\eta_y + \frac{1}{2}t\xi_x + \frac{1}{2}t\tau_t + t\phi_u = 0, \\
u_t u_z & : e^{2x}t^3\gamma_t - t\tau_z = 0, \\
u_x u_z & : -e^{2x}t\gamma_x - t\xi_z = 0, \\
u_y u_z & : -t\gamma_y - t\eta_z = 0, \\
u_t u_y & : e^{2x}t^3\eta_t - t\tau_y = 0, \\
u_y u_x & : -e^{2x}t\eta_x - t\xi_y = 0, \\
u_t u_x & : e^{2x}t^3\xi_t - e^{2x}t\tau_x = 0, \\
u_t & : -f_{1,u} - e^{2x}t^3\phi_t = 0, \\
u_x & : -f_{2,u} + e^{2x}t\phi_x = 0, \\
u_y & : -f_{3,u} + t\phi_y = 0, \\
u_z & : -f_{4,u} + t\phi_z = 0, \\
1 & : e^{2x}t^3u^2\xi + \frac{3}{2}e^{2x}t^2u^2\tau + e^{2x}t^3u\phi + \frac{1}{2}t^3e^{2x}u^2(\tau_t + \xi_x + \eta_y + \gamma_z) \\
& \quad - (f_{1,t} + f_{2,x} + f_{3,y} + f_{4,z}) = 0.
\end{aligned} \tag{43}$$

Therefore, the coefficients of the infinitesimal generator are:

$$\begin{aligned}
\gamma(t, x, y, z, u) &= \frac{1}{2t}e^{-2x}(e^x(-zc_7 + c_{11}) - tc_{12} + e^{2x}t(2y(c_1 + zc_8) + 2z(c_4 + c_5 \\
&\quad + c_{10}) \\
&\quad - y^2c_{12} + z^2c_{12} + 2(c_{13} + c_{14}))) \\
\eta(t, x, y, z, u) &= \frac{1}{2t}e^{-2x}(-e^x(c_6 + yc_7) - tc_8 + e^{2x}t(-2zc_1 + y^2c_8 - z^2c_8 \\
&\quad + 2(c_2 + c_3 + c_9) + 2y(c_4 + c_5 + c_{10} + zc_{12}))) \\
\xi(t, x, y, z, u) &= \frac{1}{4t}(e^{-x}(c_7 - 4e^{xt}(c_4 + c_5 + yc_8 + c_{10} + zc_{12}) - e^{2x}(2yc_6 + y^2c_7 \\
&\quad + z^2c_7 \\
&\quad - 2zc_{11} + 4c_{15}))) \\
\tau(t, x, y, z, u) &= \frac{1}{4}e^{-x}(c_7 + e^{2x}(2yc_6 + y^2c_7 + z^2c_7 - 2zc_{11} + 4c_{15})) \\
\phi(t, x, y, z, u) &= \mathcal{F}_1(t, x, y, z) \\
f_1(t, x, y, z, u) &= \mathcal{F}_2(t, x, y, z) - e^{2xt^3}u\mathcal{F}_{1,t} \\
f_3(t, x, y, z, u) &= \mathcal{F}_3(t, x, y, z) + tu\mathcal{F}_{1,y} \\
f_4(t, x, y, z, u) &= \mathcal{F}_4(t, x, y, z) + tu\mathcal{F}_{1,z} \\
f_2(t, x, y, z, u) &= -\int \mathcal{F}_{4,z} dx - \int \mathcal{F}_{3,y} dx - \int \mathcal{F}_{2,t} dx + \mathcal{F}_5(t, y, z) + e^{2x}tu\mathcal{F}_{1,x}.
\end{aligned} \tag{44}$$

In addition, we have the constraint,

$$-e^{2x}t^2\mathcal{F}_1(t, x, y, z) + \mathcal{F}_{1,zz} + \mathcal{F}_{1,yy} + 2e^{2x}\mathcal{F}_{1,x} + e^{2x}\mathcal{F}_{1,xx} - 3e^{2x}t\mathcal{F}_{1,t} - e^{2x}t^2\mathcal{F}_{1,tt} = 0,$$

and we set

$$\mathcal{F}_2 = \mathcal{F}_3 = \mathcal{F}_4 = \mathcal{F}_5 = 0.$$

When we separate (44), we find that the Noether point symmetries are,

$$\begin{aligned}
X_1 &= e^{2xt^3}(\frac{e^x}{t}\partial_x - e^x\partial_t), \quad f_i = 0, \\
X_2 &= e^{2xt^3}\partial_y, \quad f_i = 0, \\
X_3 &= e^{2xt^3}(\frac{e^{-x}}{t}\partial_y - e^xy\partial_t + \frac{e^xy}{t}\partial_x), \quad f_i = 0, \\
X_4 &= e^{2xt^3}\partial_z, \quad f_i = 0, \\
X_5 &= e^{2xt^3}(\frac{e^{-x}}{t}\partial_z - e^xz\partial_t + \frac{e^xz}{t}\partial_x), \quad f_i = 0, \\
X_6 &= e^{2xt^3}(y\partial_z - z\partial_y), \quad f_i = 0, \\
X_7 &= e^{2xt^3}(-\partial_x + y\partial_y + z\partial_z), \quad f_i = 0, \\
X_8 &= e^{2xt^3}(\frac{2e^{-xy}}{t}\partial_y + \frac{2e^{-xz}}{t}\partial_z + e^{-x}(-1 - e^{2x}(y^2 + z^2))\partial_t + \frac{e^{-x}(-1 + e^{2x}(y^2 + z^2))}{t}\partial_x), \\
&\quad f_i = 0, \\
X_9 &= e^{2xt^3}(2y\partial_x - 2yz\partial_z + (e^{-2x} - y^2 + z^2)\partial_y), \quad f_i = 0, \\
X_{10} &= e^{2xt^3}(-2yz\partial_y + 2z\partial_x + (e^{-2x} + y^2 - z^2)\partial_z), \quad f_i = 0,
\end{aligned}$$

The corresponding conserved densities are,

$$\begin{aligned}
\Phi_1^t &= -\frac{1}{2}e^xt(e^{2xt^2}u^2 + e^{2xt}u_t(tu_t - u_x) - u(u_{zz} + u_{yy} + e^{2x}(-3tu_t + 3u_x - tu_{xt} \\
&\quad + u_{xx}))), \\
\Phi_2^t &= -\frac{1}{2}e^{2xt^3}(u_yu_t - uu_{ty}), \\
\Phi_3^t &= \frac{1}{2}e^xt(e^{2xt^2}yu^2 + tu_t(-u_y + e^{2x}y(tu_t - u_x)) - u(yu_{zz} + u_y + yu_{yy} - 3e^{2x}tyu_t \\
&\quad - tu_{ty} + 3e^{2x}yu_x - e^{2x}tyu_{xt} + e^{2x}yu_{xx})), \\
\Phi_4^t &= -\frac{1}{2}e^{2xt^3}(u_zu_t - uu_{tz}), \\
\Phi_5^t &= \frac{1}{2}e^xt(e^{2xt^2}zu^2 + tu_t(-u_z + e^{2x}z(tu_t - u_x)) - u(u_z + zu_{zz} + zu_{yy} - 3e^{2x}tzu_t \\
&\quad - tu_{tz} + 3e^{2x}zu_x - e^{2x}tzu_{xt} + e^{2x}zu_{xx})), \\
\Phi_6^t &= -\frac{1}{2}e^{2xt^3}(yu_zu_t - zu_yu_t + u(-yu_{tz} + zu_{ty})), \\
\Phi_7^t &= -\frac{1}{2}e^{2xt^3}(zu_zu_t + yu_yu_t - zuu_{tz} - yuu_{ty} - u_tu_x + uu_{xt}),
\end{aligned}$$

$$\begin{aligned}
\Phi_8^t &= \frac{1}{2}e^{-x}t(e^{2x}t^2(1 + e^{2x}(y^2 + z^2))u^2 + e^{2x}tu_t(-2zu_z - 2yu_y + tu_t + e^{2x}ty^2u_t \\
&\quad + e^{2x}tz^2u_t + u_x - e^{2x}y^2u_x - e^{2x}z^2u_x) + u(-2e^{2x}zu_z - (1 + e^{2x}(y^2 + z^2))u_{zz} \\
&\quad - 2e^{2x}yu_y - u_{yy} - e^{2x}y^2u_{yy} - e^{2x}z^2u_{yy} + 3e^{2x}tu_t + 3e^{4x}ty^2u_t + 3e^{4x}tz^2u_t \\
&\quad + 2e^{2x}tzut_z + 2e^{2x}tyut_y - e^{2x}u_x - 3e^{4x}y^2u_x - 3e^{4x}z^2u_x - e^{2x}tu_{xt} + e^{4x}ty^2u_{xt} \\
&\quad + e^{4x}tz^2u_{xt} - e^{2x}u_{xx} - e^{4x}y^2u_{xx} - e^{4x}z^2u_{xx}), \\
\Phi_9^t &= \frac{1}{2}t^3(2e^{2x}yzu_zu_t + (-1 + e^{2x}(y^2 - z^2))u_yu_t - 2e^{2x}yzuu_{tz} + uu_{ty} \\
&\quad - e^{2x}y^2uu_{ty} + e^{2x}z^2uu_{ty} - 2e^{2x}yu_tu_x + 2e^{2x}yu_{xt}), \\
\Phi_{10}^t &= -\frac{1}{2}t^3((1 + e^{2x}(y^2 - z^2))u_zu_t - 2e^{2x}yzu_yu_t - uu_{tz} - e^{2x}y^2uu_{tz} + e^{2x}z^2uu_{tz} \\
&\quad + 2e^{2x}yzuu_{ty} + 2e^{2x}zu_tu_x - 2e^{2x}zuu_{xt}).
\end{aligned}$$

3.4 Multipliers of a Klein-Gordon equation

Consider the Klein-Gordon equation in Milne spacetime with dependent variable u as a function of x, t and y only, i.e., we have removed the spatial variable z from the original wave equation (33) - the calculations with z are extremely cumbersome producing no final outcomes. We consider the multiplier method for (33), by choosing $k(u) = u$, i.e. we consider

$$\frac{\delta}{\delta u}[\mathcal{Q}(\frac{1}{t^2}u_{xx} - u_{tt} + \frac{1}{t^2}e^{-2x}u_{yy} - \frac{3}{t}u_t + \frac{2}{t^2}u_x - u)] = 0 \quad (45)$$

where $\mathcal{Q} = \mathcal{Q}(x, y, t, u_x, u_x, u_{xx}, u_{xy}, u_{xxx}, u_{xxy}, u_{xyy}, u_{yyy})$. Although not pursued here, the calculations may include derivatives of u with respect to t . Then

$$\mathcal{Q}[(\frac{1}{t^2}u_{xx} - u_{tt} + \frac{1}{t^2}e^{-2x}u_{yy} - \frac{3}{t}u_t + \frac{2}{t^2}u_x - u)] = D_t\Phi^t + D_x\Phi^x + D_y\Phi^y,$$

where (Φ^x, Φ^y, Φ^t) is the conserved flow and Φ^t the conserved density. We obtain the set of multipliers \mathcal{Q}_i together with their conserved densities Φ_i^t , namely,

$$\begin{aligned}\mathcal{Q}_1 &= t^3 e^{2x} \left(-\frac{1}{3} u_{xxx} - \frac{1}{6} y u_y + y u_{xxy} + \frac{1}{2} y^2 u_{yy} + \frac{1}{3} y^3 u_{yyy} - y^2 u_{xyy} - \frac{1}{2} u_{xx} + \frac{1}{12} u \right), \\ \Phi_1^t &= -\frac{1}{12} e^{2x} t^3 \left(-y u_y u_t + 3y^2 u_{yy} u_t + 2y^3 u_{yyy} u_t + y u u_{ty} - 3y^2 u u_{tyy} - 2y^3 u u_{tyyy} \right. \\ &\quad \left. - 6y^2 u_t u_{xyy} + 6y^2 u u_{xtyy} - 3u_t u_{xx} + 6y u_t u_{xxy} + 3u u_{xxt} - 6y u u_{xxy} - 2u_t u_{xxx} \right. \\ &\quad \left. + 2u u_{xxxt} \right),\end{aligned}$$

$$\begin{aligned}\mathcal{Q}_2 &= t^3 e^{2x} \left(-2y u_{xyy} + u_{xxy} + y u_{yy} + y^2 u_{yyy} \right), \\ \Phi_2^t &= -\frac{1}{2} e^{2x} t^3 \left(y u_{yy} u_t + y^2 u_{yyy} u_t - y u u_{tyy} - y^2 u u_{tyyy} - 2y u_t u_{xyy} + 2y u u_{xtyy} \right. \\ &\quad \left. + u_t u_{xxy} - u u_{xxy} \right),\end{aligned}$$

$$\begin{aligned}\mathcal{Q}_3 &= \frac{1}{2} t^3 e^{-2x} u_{yyy} + t^3 u_{xxy} + t^3 e^{2x} \left(2y^3 u_{xyy} - y^3 u_{yy} - \frac{1}{2} y(u) - 3y^2 u_{xxy} + \frac{1}{2} y^2 u_y \right. \\ &\quad \left. + 3y u_{xx} + 2y u_{xxx} - \frac{1}{2} y^4 u_{yyy} \right), \\ \Phi_3^t &= \frac{1}{4} e^{-2x} t^3 \left(-e^{4x} y^2 u_y u_t + 2e^{4x} y^3 u_{yy} u_t - u_{yyy} u_t + e^{4x} y^4 u_{yyy} u_t + e^{4x} y^2 u u_{ty} \right. \\ &\quad \left. - 2e^{4x} y^3 u u_{tyy} + u u_{tyyy} - e^{4x} y^4 u u_{tyyy} - 4e^{4x} y^3 u_t u_{xyy} + 4e^{4x} y^3 u u_{xtyy} \right. \\ &\quad \left. - 6e^{4x} y u_t u_{xx} - 2e^{2x} u_t u_{xxy} + 6e^{4x} y^2 u_t u_{xxy} + 6e^{4x} y u u_{xxt} + 2e^{2x} u u_{xxy} \right. \\ &\quad \left. - 6e^{4x} y^2 u u_{xxy} - 4e^{4x} y u_t u_{xxx} + 4e^{4x} y u u_{xxxt} \right),\end{aligned}$$

$$\begin{aligned}\mathcal{Q}_4 &= \frac{1}{2} t^3 e^{2x} \left(2u_{xyy} - u_{yy} - 2y u_{yyy} \right), \\ \Phi_4^t &= \frac{1}{4} e^{2x} t^3 \left(u_{yy} u_t + 2y u_{yyy} u_t - u u_{tyy} - 2y u u_{tyyy} - 2u_t u_{xyy} + 2u u_{xtyy} \right),\end{aligned}$$

$$\begin{aligned}\mathcal{Q}_5 &= t^3 e^{2x} u_{yyy}, \\ \Phi_5^t &= -\frac{1}{2} e^{2x} t^3 \left(u_{yyy} u_t - u u_{tyyy} \right),\end{aligned}$$

$$\begin{aligned}\mathcal{Q}_6 &= t^3 e^{2x} \left(y u_x + \frac{1}{2} y u - \frac{1}{2} y^2 u_y \right) + \frac{1}{2} t^3 u_y, \\ \Phi_6^t &= \frac{1}{4} t^3 \left((-1 + e^{2x} y^2) u_y u_t - 2e^{2x} y u_t u_x + u \left((1 - e^{2x} y^2) u_{ty} + 2e^{2x} y u_{xt} \right) \right),\end{aligned}$$

$$\begin{aligned}
Q_7 &= t^3 e^{2x} (u_x + \frac{1}{2}u - yu_y), \\
\Phi_7^t &= \frac{1}{2} e^{2x} t^3 (yu_y u_t - u_t u_x + u(-yu_{ty} + u_{xt})), \\
\\
Q_8 &= t^3 e^{2x} u_y, \\
\Phi_8^t &= -\frac{1}{2} e^{2x} t^3 (u_y u_t - uu_{ty}).
\end{aligned}$$

3.5 Conclusion

This chapter investigates a class of wave and Gordon-type equations in Milne spacetime. In particular, we conducted a Lie and Noether symmetry analysis of a Klein-Gordon equation on this manifold. We have given some symmetry reductions to show how the (1+3) dimensional wave equation can be reduced to an ordinary differential equation using the method of invariants and we obtained some exact solutions. The conserved densities of the Klein-Gordon equation are constructed. Finally, some higher-order symmetries for the projected equation and associated conservation laws are presented. It is hoped that an analysis of the nonlinear wave equation in a genuinely curved spacetime will provide more insights in relativity and geometry via reduction or otherwise in conserved quantities.

Chapter 4

The Bianchi III Spacetime

4.1 Introduction

Several investigations in the literature have been aimed at the Bianchi universes. In [46] the Bianchi universes were investigated using Noether symmetries. The authors of [47] studied the Noether symmetries of Bianchi type I and III spacetimes in scalar coupled theories. Therein, they obtained the exact solutions for potential functions, scalar field and the scale factors, see also [48].

We pursue an investigation of the symmetries of the wave equation in Bianchi III spacetime. The plan of the chapter is as follows. First, in section 4.2 we implement the multiplier approach in order to find the evolutionary generators and conserved densities of the wave equation. Second, in section 4.3, we use the classical Noether approach to determine symmetry generators of the wave equation and find conservation laws associated with the Noether symmetries. This procedure yields a wider

range of results. Thereafter we perform symmetry reductions of the wave equation to obtain invariant solutions.

The Bianchi III metric is given by

$$ds^2 = -\beta^2 dt^2 + t^{2L}(dx^2 + e^{-\frac{2ax}{N}} dy^2) + t^{\frac{2L}{m}} dz^2. \quad (46)$$

The application of the d'Alembertian operator yields the wave equation on (46), i.e., [17]

$$\begin{aligned} & -\frac{1}{\beta}(2L+1)t^{2L}e^{-\frac{ax}{N}}u_t - \frac{1}{\beta}t^{2L+1}e^{-\frac{ax}{N}}u_{tt} \\ & -\frac{a\beta}{N}te^{-\frac{ax}{N}}u_x + \beta te^{-\frac{ax}{N}}u_{xx} \\ & +\beta te^{\frac{ax}{N}}u_{yy} + \beta t^{2L+1-\frac{2L}{m}}e^{-\frac{ax}{N}}u_{zz} = 0. \end{aligned} \quad (47)$$

4.2 Symmetries of the wave equation - the multiplier approach

The multiplier method [3] is adopted to determine some of the conserved densities. Since the Euler-Lagrange operator annihilates total divergences, a multiplier $Q \in \mathcal{A}$ satisfies

$$\frac{\delta}{\delta u}[Q.\text{LHS of (47)}] = 0. \quad (48)$$

Q is chosen to be first order in derivatives of u , i.e., $Q = Q(x, y, z, t, u_x, u_t, u_y, u_z)$.

Lengthy calculations lead to the set of multipliers defined by

$$\begin{aligned} Q = & C_1 u_y + C_2 u_z + e^{\frac{ax}{2N}} \\ & (C_3 e^{\frac{x\sqrt{a^2\beta^2+4N^2d_1}}{2N\beta}} + C_4 e^{-\frac{x\sqrt{a^2\beta^2+4N^2d_1}}{2N\beta}})Y(t), \end{aligned} \quad (49)$$

where d_1 and C_i ($i = 1, 2, 3, 4$) are arbitrary constants and $Y(t)$ is the solution of

$$-t^{-2L+1}d_1Y + Y_t(2L+1)t^{-1} + Y_{tt} = 0.$$

We let $d_1 = 0$, to solve

$$Y_{tt} + \frac{(2L+1)}{t}Y_t = 0$$

and obtain

$$Y(t) = -\frac{t^{-2L}}{2L}v + w,$$

where v, w are arbitrary constants. We thus obtain the multipliers Q_1, Q_2, Q_3 with corresponding evolutionary operators $X_i = Q_i \partial_u$, viz.,

$$\begin{aligned} X_1 &= u_z \partial_u, \\ X_2 &= u_y \partial_u, \\ X_3 &= \left(-p \frac{t^{-2L}}{2L} e^{\frac{\alpha}{N}x} - q \frac{t^{-2L}}{2L} + s e^{\frac{\alpha}{N}x} + r \right) \partial_u, \end{aligned}$$

where, p, q, r, s are arbitrary constants. It can be shown that the X_i are variational and lead to conservation laws, for example, the corresponding conserved densities for each X_i are

$$\begin{aligned} \Phi_1^t &= \frac{1}{2\beta} e^{-\frac{\alpha x}{N}} t^{1+2L} (-u_z u_t + u u_{tz}), \\ \Phi_2^t &= \frac{1}{2\beta} e^{-\frac{\alpha x}{N}} t^{1+2L} (-u_y u_t + u u_{ty}), \\ \Phi_3^t &= \frac{1}{2L\beta} e^{-\frac{\alpha x}{N}} (2L(e^{\frac{\alpha x}{N}} p + q)u + t(q - 2Lrt^{2L} \\ &\quad + e^{\frac{\alpha x}{N}}(p - 2Lst^{2L}))u_t). \end{aligned}$$

4.3 Symmetries of the wave equation - the Noether approach

In this section, we investigate the wave equation on the Bianchi III metric using the notation of differential forms (see section 1.7), and the Noether approach [8]. To avoid ambiguity, the Lagrangian will be denoted by \mathbf{L} in section 4.3.

We classify the cases that yield strict Noether symmetries (gauge is zero) of (47),

using the Lagrangian

$$\mathbf{L} = -\frac{\beta}{2}te^{-\frac{a}{N}x}u_x^2 - \frac{\beta}{2}te^{\frac{a}{N}x}u_y^2 - \frac{\beta}{2}t^{2L+1-\frac{2L}{m}}e^{-\frac{a}{N}x}u_z^2 + \frac{1}{2\beta}t^{2L+1}e^{-\frac{a}{N}x}u_t^2.$$

Many of the calculations have been left out as they are tedious - the details are available to the reader in a number of texts that have been cited here.

The principle Noether algebra is

$$\begin{aligned} X_1 &= \partial_y, \\ X_2 &= \partial_z, \\ X_3 &= \partial_u, \\ X_4 &= \frac{N}{a}\partial_x + y\partial_y, \\ X_5 &= \frac{-2ay}{N}\partial_x + \frac{1}{N^2}(-a^2y^2 + N^2e^{\frac{2ax}{N}})\partial_y. \end{aligned}$$

Furthermore, specific cases of L and m give rise to the symmetries X_1 to X_5 from above, and some additional symmetries.

CASE I. $L = 1, m = \frac{1}{3}$. The additional symmetries are

$$\begin{aligned} X_6 &= -2z\partial_z + t\partial_t, \\ X_7 &= -\left(\frac{4z^2t^4 + \beta^2}{4t^4}\right)\partial_z + zt\partial_t. \end{aligned}$$

CASE II. $L = 1, m = -1$. The additional symmetry is

$$X_8 = -z\partial_z - \frac{t}{2}\partial_t + u\partial_u.$$

CASE III. $L = 1, m = 1$. The additional symmetry is

$$X_9 = -t\partial_t + u\partial_u.$$

Table 4.1. contains the conserved forms corresponding to each Noether symmetry X_i ($i = 1, \dots, 9$), i.e., it lists the three form ω . The four form is $D\omega$, which vanishes on the solutions of (47). Thus

$$\omega = -\Phi^t dx \wedge dy \wedge dz + \Phi^z dx \wedge dy \wedge dt - \Phi^y dx \wedge dz \wedge dt + \Phi^x dy \wedge dz \wedge dt$$

so that

$$D_t \Phi^t + D_x \Phi^x + D_y \Phi^y + D_z \Phi^z = 0$$

on (47).

Table 4.1. Conserved Form ω	
X_1	$\Phi^t = \frac{e^{-\frac{\alpha x}{N} t^{1+2L} (-u_y u_t + u u_{ty})}}{2\beta}, \quad \Phi^x = \frac{1}{2} e^{-\frac{\alpha x}{N} t} \beta (u_y u_x - u u_{xy}),$ $\Phi^y = \frac{e^{-\frac{\alpha x}{N} t} t^{-\frac{2L}{m}} (e^{\frac{2\alpha x}{N}} N t^{1+\frac{2L}{m}} \beta^2 u_y^2 + u (N t^{1+2L} \beta^2 u_{zz} - t^{\frac{2L}{m}} (at\beta^2 u_x + N(-t\beta^2 u_{xx} + t^{2L}((1+2L)u_t + t u_{tt}))))))}{2N\beta},$ $\Phi^z = \frac{1}{2} e^{-\frac{\alpha x}{N} t^{1+\frac{2L(-1+m)}{m}}} \beta (u_z u_y - u u_{yz})$
X_2	$\Phi^t = \frac{e^{-\frac{\alpha x}{N} t^{1+2L} (-u_z u_t + u u_{tz})}}{2\beta}, \quad \Phi^x = \frac{1}{2} e^{-\frac{\alpha x}{N} t} \beta (u_z u_x - u u_{xz}),$ $\Phi^y = \frac{1}{2} e^{\frac{\alpha x}{N} t} \beta (u_z u_y - u u_{yz}),$ $\Phi^z = \frac{e^{-\frac{\alpha x}{N} t} t^{-\frac{2L}{m}} (N t^{1+2L} \beta^2 u_z^2 + t^{\frac{2L}{m}} u (e^{\frac{2\alpha x}{N}} N t \beta^2 u_{yy} - at\beta^2 u_x + N(t\beta^2 u_{xx} - t^{2L}((1+2L)u_t + t u_{tt}))))}{2N\beta}$
X_3	$\Phi^t = -\frac{e^{-\frac{\alpha x}{N} t^{1+2L} u_t}}{\beta}, \quad \Phi^x = e^{-\frac{\alpha x}{N} t} \beta u_x,$ $\Phi^y = e^{\frac{\alpha x}{N} t} \beta u_y, \quad \Phi^z = e^{-\frac{\alpha x}{N} t^{1+2L} - \frac{2L}{m}} \beta u_z$
X_4	$\Phi^t = -\frac{e^{-\frac{\alpha x}{N} t^{1+2L} (a y u_y u_t + N u_x u_t - u (a y u_{ty} + N u_{tx}))}}{2a\beta},$ $\Phi^x = \frac{1}{2a\beta} (e^{-\frac{\alpha x}{N} t} t^{-\frac{2L}{m}} (t^{1+\frac{2L}{m}} \beta^2 u_x (a y u_y + N u_x) + u (N t^{1+2L} \beta^2 u_{zz} + t^{\frac{2L}{m}} (e^{\frac{2\alpha x}{N}} N t \beta^2 u_{yy} - at\beta^2 u_x - aty\beta^2 u_{xy} - N t^{2L} u_t - 2L N t^{2L} u_t - N t^{1+2L} u_{tt}))))),$ $\Phi^y = \frac{1}{2aN\beta} e^{-\frac{\alpha x}{N} t} t^{-\frac{2L}{m}} (e^{\frac{2\alpha x}{N}} N t^{1+\frac{2L}{m}} \beta^2 u_y (a y u_y + N u_x) + u (aN t^{1+2L} y \beta^2 u_{zz} - t^{\frac{2L}{m}} (a e^{\frac{2\alpha x}{N}} N t \beta^2 u_y + a^2 t y \beta^2 u_x + N (e^{\frac{2\alpha x}{N}} N t \beta^2 u_{xy} + ay(-t\beta^2 u_{xx} + t^{2L}((1+2L)u_t + t u_{tt})))))),$ $\Phi^z = \frac{e^{-\frac{\alpha x}{N} t^{1+\frac{2L(-1+m)}{m}}} \beta (u_z (a y u_y + N u_x) - u (a y u_{yz} + N u_{xz}))}{2a}$

X_5	$\begin{aligned} \Phi^t &= \frac{1}{2N^2\beta} (e^{-\frac{\alpha x}{N}} t^{1+2L} (- (e^{\frac{2\alpha x}{N}} N^2 - a^2 y^2) u_y u_t + 2aNy u_x u_t \\ &\quad + u((e^{\frac{2\alpha x}{N}} N^2 - a^2 y^2) u_{ty} - 2aNy u_{tx}))), \\ \Phi^x &= \frac{1}{2N^2\beta} e^{-\frac{\alpha x}{N}} t^{-\frac{2L}{m}} (t^{1+\frac{2L}{m}} \beta^2 u_x ((e^{\frac{2\alpha x}{N}} N^2 - a^2 y^2) u_y - 2aNy u_x) \\ &\quad + u(-2aNt^{1+2L} y \beta^2 u_{zz} + t^{\frac{2L}{m}} (-2ae^{\frac{2\alpha x}{N}} Nt \beta^2 u_y - 2ae^{\frac{2\alpha x}{N}} Nty \beta^2 u_{yy} \\ &\quad + 2a^2 ty \beta^2 u_x - e^{\frac{2\alpha x}{N}} N^2 t \beta^2 u_{xy} + a^2 ty^2 \beta^2 u_{xy} + 2aNt^{2L} y u_t \\ &\quad + 4aLNt^{2L} y u_t + 2aNt^{1+2L} y u_{tt}))), \\ \Phi^y &= \frac{1}{2N^3\beta} e^{-\frac{\alpha x}{N}} t^{-\frac{2L}{m}} (e^{\frac{2\alpha x}{N}} Nt^{1+\frac{2L}{m}} \beta^2 u_y ((e^{\frac{2\alpha x}{N}} N^2 \\ &\quad - a^2 y^2) u_y - 2aNy u_x) + u(Nt^{1+2L} (e^{\frac{2\alpha x}{N}} N^2 - a^2 y^2) \beta^2 u_{zz} \\ &\quad + t^{\frac{2L}{m}} (2a^2 e^{\frac{2\alpha x}{N}} Nty \beta^2 u_y + at(e^{\frac{2\alpha x}{N}} N^2 + a^2 y^2) \beta^2 u_x \\ &\quad + N(2ae^{\frac{2\alpha x}{N}} Nty \beta^2 u_{xy} + (e^{\frac{2\alpha x}{N}} N^2 - a^2 y^2)(t \beta^2 u_{xx} - t^{2L}((1+2L)u_t + tu_{tt})))))), \\ \Phi^z &= \frac{e^{-\frac{\alpha x}{N}} t^{1+\frac{2L(-1+m)}{m}} \beta (u_z ((e^{\frac{2\alpha x}{N}} N^2 - a^2 y^2) u_y - 2aNy u_x) - u((e^{\frac{2\alpha x}{N}} N^2 - a^2 y^2) u_{yz} - 2aNy u_{xz}))}{2N^2} \end{aligned}$
X_6	$\begin{aligned} \Phi^t &= \frac{1}{2Nt^2\beta} (e^{-\frac{\alpha x}{N}} (Nt^5 u_t (2zu_z - tu_t) + u(N\beta^2 u_{zz} + t^4 (e^{\frac{2\alpha x}{N}} N\beta^2 u_{yy} \\ &\quad - a\beta^2 u_x + N\beta^2 u_{xx} - 2Ntu_t - 2Ntz u_{tz}))), \\ \Phi^x &= \frac{1}{2} e^{-\frac{\alpha x}{N}} t\beta (-2zu_z u_x + tu_x u_t + u(2zu_{xz} - tu_{tx})), \\ \Phi^y &= \frac{1}{2} e^{\frac{\alpha x}{N}} t\beta (-2zu_z u_y + tu_y u_t + u(2zu_{yz} - tu_{ty})), \\ \Phi^z &= \frac{1}{2Nt^3\beta} (e^{-\frac{\alpha x}{N}} (N\beta^2 u_z (-2zu_z + tu_t) + u(2N\beta^2 u_z - 2e^{\frac{2\alpha x}{N}} Nt^4 z \beta^2 u_{yy} \\ &\quad + 2at^4 z \beta^2 u_x - 2Nt^4 z \beta^2 u_{xx} + 6Nt^5 z u_t - Nt\beta^2 u_{tz} + 2Nt^6 z u_{tt}))) \end{aligned}$
X_7	$\begin{aligned} \Phi^t &= \frac{1}{8Nt^2\beta} (e^{-\frac{\alpha x}{N}} (Ntu_t ((4t^4 z^2 + \beta^2) u_z - 4t^5 z u_t) + u(4N\beta^2 u_z + 4Nz\beta^2 u_{zz} \\ &\quad + 4e^{\frac{2\alpha x}{N}} Nt^4 z \beta^2 u_{yy} - 4at^4 z \beta^2 u_x + 4Nt^4 z \beta^2 u_{xx} - 8Nt^5 z u_t - 4Nt^5 z^2 u_{tz} - Nt\beta^2 u_{tz}))), \\ \Phi^x &= \frac{e^{-\frac{\alpha x}{N}} \beta (- (4t^4 z^2 + \beta^2) u_z u_x + 4t^5 z u_x u_t + ((4t^4 z^2 + \beta^2) u_{xz} - 4t^5 z u_{tx}))}{8t^3}, \\ \Phi^y &= \frac{e^{\frac{\alpha x}{N}} \beta (- (4t^4 z^2 + \beta^2) u_z u_y + 4t^5 z u_y u_t + u((4t^4 z^2 + \beta^2) u_{yz} - 4t^5 z u_{ty}))}{8t^3}, \\ \Phi^z &= \frac{1}{8Nt^7\beta} e^{-\frac{\alpha x}{N}} (-N\beta^2 u_z ((4t^4 z^2 + \beta^2) u_z - 4t^5 z u_t) + t^4 u(8Nz\beta^2 u_z \\ &\quad - e^{\frac{2\alpha x}{N}} N\beta^2 (4t^4 z^2 + \beta^2) u_{yy} + 4at^4 z^2 \beta^2 u_x + a\beta^4 u_x - 4Nt^4 z^2 \beta^2 u_{xx} - N\beta^4 u_{xx} \\ &\quad + 12Nt^5 z^2 u_t - Nt\beta^2 u_t - 4Ntz\beta^2 u_{tz} + 4Nt^6 z^2 u_{tt} + Nt^2 \beta^2 u_{tt})) \end{aligned}$

X_8	$\Phi^t = \frac{1}{4N\beta} (e^{-\frac{ax}{N}} t^2 (-Ntu_t(2zu_z + tu_t) + u(Nt^4\beta^2u_{zz} + e^{\frac{2ax}{N}} N\beta^2u_{yy} - a\beta^2u_x + N\beta^2u_{xx} - 2Ntu_t + 2Ntzu_{tz}))),$ $\Phi^x = \frac{1}{4} e^{-\frac{ax}{N}} t\beta(2zu_zu_x + tu_xu_t - u(2zu_{xz} + tu_{tx})),$ $\Phi^y = \frac{1}{4} e^{\frac{ax}{N}} t\beta(2zu_zu_y + tu_yu_t - u(2zu_{yz} + tu_{ty})),$ $\Phi^z = \frac{1}{4N\beta} (e^{-\frac{ax}{N}} t(Nt^4\beta^2u_z(2zu_z + tu_t) - u(2Nt^4\beta^2u_z - 2e^{\frac{2ax}{N}} nz\beta^2u_{yy} + 2az\beta^2u_x - 2Nz\beta^2u_{xx} + 6Ntzu_t + Nt^5\beta^2u_{tz} + 2Nt^2zu_{tt})))$
X_9	$\Phi^t = \frac{1}{2N\beta} (e^{-\frac{ax}{N}} t^2 (-Nt^2u_t^2 + u(N\beta^2u_{zz} + e^{\frac{2ax}{N}} N\beta^2u_{yy} - a\beta^2u_x + N\beta^2u_{xx} - 2Ntu_t))),$ $\Phi^x = \frac{1}{2} e^{-\frac{ax}{N}} t^2\beta(u_xu_t - uu_{tx}), \quad \Phi^y = \frac{1}{2} e^{\frac{ax}{N}} t^2\beta(u_yu_t - uu_{ty}),$ $\Phi^z = \frac{1}{2} e^{-\frac{ax}{N}} t^2\beta(u_zu_t - uu_{tz})$

4.3.1 Symmetry reduction and invariant solutions

We illustrate how the order of the (1+3) wave equation (47) can be reduced. The equation with four independent variables is reduced to an ordinary differential equation.

(i). *Reduction - using the principle Noether algebra.*

We begin reducing (47) using X_2 followed by X_4 . The characteristic equations are

$$\frac{adx}{N} = \frac{dt}{0} = \frac{dy}{y} = \frac{du}{0}.$$

Integrating yields $s = ye^{-\frac{a}{N}x}$ and (47) is reduced to

$$-\frac{1}{\beta} t^{2L} u_{tt} - \frac{1}{\beta} (2L + 1) t^{2L} u_t + \beta t (1 + \frac{a^2}{N^2} s^2) u_{ss} + 2s \frac{a^2}{N^2} \beta t u_s = 0 \quad (50)$$

with $u = u(s, t)$.

A Lagrangian of (50) is

$$\mathbf{L} = -\frac{1}{\beta}t^{2L+1}\frac{u_t^2}{2} + \beta t\left(1 + \frac{a^2}{N^2}s^2\right)\frac{u_s^2}{2}.$$

It turns out that we if we let $L = 1, N = 1$ in (50), we can obtain its Noether symmetries, viz,

$$X_1^* = t\partial_t - u\partial_u, \quad X_2^* = \partial_u$$

We reduce (50) with X_1^* , and the characteristic equations are

$$\frac{dt}{t} = \frac{ds}{0} = \frac{du}{-u}.$$

Integrating yields $Y = tu$ and (50) is reduced to the ordinary differential equation

$$\frac{1}{\beta}Y + \beta(1 + s^2a^2)Y_{ss} + 2a^2\beta sY_s = 0 \quad (51)$$

with $Y = Y(s)$, and which has a solution in terms of special functions, i.e.,

$$Y(s) = C_1 \text{LegendreP} \left[\frac{-a\beta + \sqrt{-4 + a^2\beta^2}}{2a\beta}, ias \right] + C_2 \text{LegendreQ} \left[\frac{-a\beta + \sqrt{-4 + a^2\beta^2}}{2a\beta}, ias \right], \quad (52)$$

where C_1, C_2 are arbitrary constants, $\text{LegendreP}[n, x]$ refers to the Legendre polynomial $P_n(x)$ and $\text{Q}[n, z]$ refers to the Legendre function of the second kind $Q_n(z)$.

(ii). *Reduction - CASE I, $L = 1, m = \frac{1}{3}$.*

We reduce (47) using X_1 followed by X_6 from CASE I. The characteristic equations are

$$\frac{dz}{-2z} = \frac{dt}{t} = \frac{dx}{0} = \frac{du}{0}.$$

Integrating yields $r = t^2z$ and (47) is reduced to

$$-\frac{8}{\beta}re^{-\frac{ax}{N}}u_r - \frac{a\beta}{N}e^{-\frac{ax}{N}}u_x + \beta e^{-\frac{ax}{N}}u_{xx} + e^{-\frac{ax}{N}}\left(\frac{\beta^2 - 4r^2}{\beta}\right)u_{rr} = 0 \quad (53)$$

with $u = u(r, x)$.

A Lagrangian of (53) is

$$\mathbf{L} = \beta e^{-\frac{ax}{N}} \frac{u_x^2}{2} + e^{-\frac{ax}{N}} \left(\frac{\beta^2 - 4r^2}{\beta} \right) \frac{u_r^2}{2}.$$

Hence, we obtain the Noether symmetries of (53), viz,

$$X_3^* = \partial_x + \frac{a}{2N} u \partial_u, \quad X_4^* = \partial_u$$

We reduce (53) with X_3^* , and the characteristic equations are

$$\frac{dx}{1} = \frac{dr}{0} = \frac{2N du}{au}.$$

Integrating yields $Z = e^{-\frac{ax}{2N}} u$ and (53) is reduced to the ordinary differential equation

$$-\frac{8}{\beta} r Z_r + \left(\frac{\beta^2 - 4r^2}{\beta} \right) Z_{rr} - \frac{a^2 \beta}{4N^2} Z = 0 \quad (54)$$

with $Z = Z(r)$, and which has a solution in terms of special functions, i.e.,

$$\begin{aligned} Z(r) = & C_1 \text{LegendreP} \left[\frac{-2N + \sqrt{4N^2 - a^2 \beta^2}}{4N}, \frac{2r}{\beta} \right] \\ & + C_2 \text{LegendreQ} \left[\frac{-2N + \sqrt{4N^2 - a^2 \beta^2}}{4N}, \frac{2r}{\beta} \right], \end{aligned} \quad (55)$$

where, as before, C_1, C_2 are arbitrary constants, $\text{LegendreP}[n, x]$ refers to the Legendre polynomial $P_n(x)$ and $Q[n, z]$ refers to the Legendre function of the second kind $Q_n(z)$.

4.4 Conclusion

We have classified the Noether symmetry generators, determined the conserved forms and reduced some cases of the underlying equations associated with the wave

equation on the Bianchi III manifold. The first reduction done above involved the principle Noether algebra whilst the second dealt with a particular case. To obtain other reductions, one would need to find a three dimensional subalgebra of symmetries to reduce to an ordinary differential equation whose solution would be an invariant solution, invariant under the subalgebra. Alternatively, a lower dimensional subalgebra can be used to reduce to a partial differential equation which may be tackled using other methods. The final solution in this case will be invariant only under the lower dimensional algebra. In general, the procedure performed above is the most convenient.

Chapter 5

The Friedmann-Robertson-Walker Spacetime

5.1 Introduction

In 1922, Alexander Friedmann found a solution to Einstein's field equations that suggests an expanding universe. Georges Lemaître proposed a creation event as the beginning of the universe expansion. These ideas combined with the metric by Howard Robertson and Arthur Walker, are commonly referred to the Friedmann-Lemaître-Robertson-Walker or just Friedmann-Robertson-Walker (FRW) solution of the gravity equations, and are believed to be the best fit to describe our universe evolution [49]. The FRW spacetime represents, in conformity with general relativity, the universe at a very large scale, where it is assumed to be homogeneous and isotropic [50]. The importance of the FRW metric in cosmology has been discussed widely in the literature and requires no further introduction here.

In [51] $f(R)$ gravity for spherically symmetric spacetime was discussed using Noether symmetries. The authors of [52] found Noether symmetries for the flat FRW model in $f(R)$ gravity.

In this chapter, we first discuss the symmetries of the FRW spacetime for different curvatures. The d'Alembertian operator is then used to construct the wave and Klein-Gordon equation in FRW spacetime. We provide a detailed symmetry analysis of the underlying wave equations on this metric. In section 5.2 the isometries of the metric are listed. Thereafter, section 5.3 presents the wave and Klein-Gordon equation in FRW spacetime. We provide the symmetries of the wave equations and the conserved quantities are constructed. Also, we discuss a symmetry reduction and provide exact solutions to the wave equation in FRW universe.

Regarding the FRW space-time, the line element in (1+3) dimensions and in stereographic coordinates, is given by

$$ds^2 = -dt^2 + \frac{a^2(t)}{\left(1 + \frac{kr^2}{4}\right)^2} (dx^2 + dy^2 + dz^2), \quad (56)$$

where $a^2(t)$ is an arbitrary (non-zero) scale factor, $k = 0, \pm 1$ refers to curvature and $r^2 = x^2 + y^2 + z^2$.

Note. The space-times with constant curvature are a special case of the FRW space-times. It is well-known that the FRW metrics are conformally flat and hence these metrics admit the maximum number of independent symmetry vectors.

5.2 Noether symmetries of the FRW metric

The Euler-Lagrange (geodesic) equations associated with the Lagrangian

$$L = -\dot{t}^2 + \frac{a^2(t)}{\left(1 + \frac{k(x^2+y^2+z^2)}{4}\right)^2} (\dot{x}^2 + \dot{y}^2 + \dot{z}^2),$$

corresponding to (56) are

$$\begin{aligned} \ddot{t} &= \frac{1}{(4+k(x^2+y^2+z^2))^2} (2(16a(t)a_t(\dot{x}^2 + \dot{y}^2 + \dot{z}^2) + 16\ddot{t} + 8\dot{t}k(x^2 + y^2 + z^2) \\ &\quad + \dot{t}k^2(x^4 + y^4 + z^4) + 2\dot{t}k^2(x^2y^2 + y^2z^2 + x^2z^2))), \\ \ddot{x} &= \frac{1}{(4+k(x^2+y^2+z^2))^3} (32a(t)(2a(t)kx(-\dot{x}^2 + \dot{y}^2 + \dot{z}^2) + 8a_t\dot{x}t \\ &\quad + 2a_tk\dot{x}t(x^2 + y^2 + z^2) + a(t)\ddot{x}k(x^2 + y^2 + z^2) + 4a(t)\ddot{x} - 4a(t)\dot{x}k(y\dot{y} + z\dot{z}))), \\ \ddot{y} &= \frac{1}{(4+k(x^2+y^2+z^2))^3} (32a(t)(2a(t)ky(\dot{x}^2 - \dot{y}^2 + \dot{z}^2) + 8a_t\dot{y}t \\ &\quad + 2a_tk\dot{y}t(x^2 + y^2 + z^2) + a(t)\ddot{y}k(x^2 + y^2 + z^2) + 4a(t)\ddot{y} - 4a(t)\dot{y}k(x\dot{x} + z\dot{z}))), \\ \ddot{z} &= \frac{1}{(4+k(x^2+y^2+z^2))^3} (32a(t)(2a(t)kz(\dot{x}^2 + \dot{y}^2 - \dot{z}^2) + 8a_t\dot{z}t \\ &\quad + 2a_tk\dot{z}t(x^2 + y^2 + z^2) + a(t)\ddot{z}k(x^2 + y^2 + z^2) + 4a(t)\ddot{z} - 4a(t)\dot{z}k(y\dot{y} + x\dot{x}))). \end{aligned} \tag{57}$$

where $\dot{\alpha}$ refers to the derivative of α with respect to the arclength parameter s . The geodesic equations are constructed by applying the Euler-Lagrange operator onto the Lagrangian for each variable (t, x, y, z) .

The Noether symmetries of the Euler-Lagrange equations (57) are obtained from (14) take the form $X = \tau\partial_t + \xi\partial_x + \eta\partial_y + \gamma\partial_z + \sigma\partial_s$. In detailed calculations, not to be presented here, it turns out that the algebra of Noether symmetries splits into two cases depending on the value of the curvature k .

Case (1) $k = 0$.

$$\begin{aligned}
X_1^1 &= \partial_t, & X_2^1 &= \partial_x, & X_3^1 &= \partial_y, & X_4^1 &= \partial_z, \\
X_5^1 &= x\partial_y - y\partial_x, & X_6^1 &= x\partial_z - z\partial_x, & X_7^1 &= y\partial_z - z\partial_y, \\
X_8^1 &= a^2(t)z\partial_t + t\partial_z, \\
X_9^1 &= a^2(t)y\partial_t + t\partial_y, \\
X_{10}^1 &= a^2(t)x\partial_t + t\partial_x, \\
X_{11}^1 &= 2s\partial_s + t\partial_t + x\partial_x + y\partial_y + z\partial_z, \\
X_{12}^1 &= \partial_s.
\end{aligned}$$

It turns out that all of the Noether symmetries are based on zero gauge and contain the isometries of the metric. In fact, the isometries are the Noether symmetries which have no arclength parameter s in the list above. Hence, X_1^1 to X_{10}^1 form the 10-dimensional algebra of isometries, keeping in mind that $n = 4$ corresponds to the maximal $\frac{1}{2}n(n + 1) = 10$ -dimensional algebra, $SO(1, 4)$. That is, the FRW metric with $k = 0$ is (indeed) ‘flat’- not in the sense of Minkowski whose respective Noether algebra for the Euler-Lagrange (geodesics) equations is 17-dimensional arising from some (five) non-zero gauge vector fields that leave the action integral invariant. Rather, what we see here is that this case displays properties that are in line with the de Sitter metric whose geodesic equations also admit just two additional Noether symmetries to the ten isometries of the metric. Each of the vectors above lead to conserved quantities via Noether’s theorem. Respectively, we have conservation of energy, linear momenta, angular momenta and X_8^1 to X_{10}^1 are equivalent to Lorentz rotation. The conservation laws associated with X_{11}^1 and X_{12}^1 are not physical but have other applications such as a mathematical application in the double reduction of the Euler-Lagrange equations.

Case (2) $k \neq 0$.

$$\begin{aligned}
X_1^2 &= \partial_t, & X_2^2 &= x\partial_z - z\partial_x, & X_3^2 &= x\partial_y - y\partial_x, & X_4^2 &= y\partial_z - z\partial_y, \\
X_5^2 &= xy\partial_y + zx\partial_z + \frac{1}{2} \frac{(4+k(-y^2-z^2+x^2))\partial_x}{k}, \\
X_6^2 &= -xz\partial_x - zy\partial_y + \frac{1}{2} \frac{(-4+k(y^2-z^2+x^2))\partial_z}{k}, \\
X_7^2 &= xy\partial_x + zy\partial_z - \frac{1}{2} \frac{(-4+k(-y^2+z^2+x^2))\partial_y}{k}, \\
X_8^2 &= \partial_s.
\end{aligned} \tag{58}$$

Here X_1^2 to X_7^2 form the seven isometries of the FRW metric with $k \neq 0$.

5.3 The wave and Klein-Gordon equation

Our analysis is now directed at the nonlinear wave equation in FRW geometry. For this purpose, we construct the wave and Klein-Gordon equation on this manifold with the intent of finding the symmetries of the constructed wave equation.

The Klein-Gordon equation on (56) is generated by

$$\Box u = G(u) \Rightarrow \frac{1}{\sqrt{|-g|}} \frac{\partial}{\partial x^i} \left(\sqrt{|-g|} g^{ik} \frac{\partial u}{\partial x^k} \right) = G(u), \tag{59}$$

where \Box refers to the d'Alembertian operator.

In the FRW universe, the equation written out explicitly in coordinates is

$$\begin{aligned}
&\left(1 + \frac{k(x^2+y^2+z^2)}{4}\right) \left[\left(1 + \frac{k(x^2+y^2+z^2)}{4}\right) (u_{xx} + u_{yy} + u_{zz}) - \frac{k}{2} (xu_x + yu_y + zu_z) \right] \\
&- a^2(t) \left(u_{tt} + \frac{3\dot{a}(t)}{a(t)} u_t \right) - a^2(t) G(u) = 0.
\end{aligned} \tag{60}$$

The wave equation $\square u = 0$, i.e. when $G(u) = 0$, is given by

$$\left(1 + \frac{k(x^2+y^2+z^2)}{4}\right) \left[\left(1 + \frac{k(x^2+y^2+z^2)}{4}\right) (u_{xx} + u_{yy} + u_{zz}) - \frac{k}{2} (xu_x + yu_y + zu_z)\right] - a^2(t) \left(u_{tt} + \frac{3\dot{a}(t)}{a(t)} u_t\right) = 0. \quad (61)$$

5.3.1 Noether symmetries

Noether's theorem may only be applied to the case when $k = 0$, as the cases $k = \pm 1$ yield non-variational equations.

The corresponding Lagrangians for (60) and (61) with $k = 0$ are,

$$L = -\frac{1}{2}a^3(t)u_t^2 + \frac{1}{2}a(t)(u_x^2 + u_y^2 + u_z^2) + a^3(t)H(u), \quad (62)$$

where $H(u) = \int Gd(u)$, and

$$L = -\frac{1}{2}a^3(t)u_t^2 + \frac{1}{2}a(t)(u_x^2 + u_y^2 + u_z^2), \quad (63)$$

respectively.

As mentioned before, the case $k = 0$ is 'flat' and one would expect a maximal dimensional algebra for the wave and Klein-Gordon equations [6] on the FRW manifold. However, for our purposes, we present only the strict Noether symmetries (i.e. gauge equal to zero) of equations (60) and (61). The additional symmetries may be found by setting the gauge to be non-zero. Let

$$X = \xi\partial_x + \tau\partial_t + \eta\partial_y + \gamma\partial_z + \phi\partial_u$$

be a Noether point operator that satisfies (14). It can then be shown that equation (61) admits a 7-dimensional algebra of strict point symmetry generators with basis (Noether symmetries) given by

$$\begin{aligned}
X_1 &= \partial_u, & X_2 &= \partial_x, & X_3 &= \partial_y, & X_4 &= \partial_z, \\
X_5 &= x\partial_y - y\partial_x, & X_6 &= x\partial_z - z\partial_x, & X_7 &= y\partial_z - z\partial_y.
\end{aligned} \tag{64}$$

Equation (60) with $G(u) = u$ (i.e. the Klein-Gordon equation) admits six strict Noether point symmetry generators given by X_2 to X_7 from (64).

It is clear that for the wave and Klein-Gordon equations, energy is not conserved but linear and angular momenta are.

5.3.2 Conserved forms

Below in Table 5.1 is a list of the conserved forms associated with the symmetries (64), where $(\Phi^t, \Phi^x, \Phi^y, \Phi^z)$ is the conserved vector and

$$D_t\Phi^t + D_x\Phi^x + D_y\Phi^y + D_z\Phi^z = 0$$

on (61) with $k = 0$.

Note. These are obtained by Noether's theorem [8].

Table 5.1. Conserved Forms	
X_1	$\Phi^t = -a(t)^3 u_t, \quad \Phi^x = a(t)u_x,$ $\Phi^y = a(t)u_y, \quad \Phi^z = a(t)u_z$
X_2	$\Phi^t = \frac{1}{2}a(t)^3(-u_x u_t + u u_{tx}), \quad \Phi^x = \frac{1}{2}a(t)(u_x^2 + u(u_{zz} + u_{yy} - a(t)(3a'u_t + a(t)u_{tt}))),$ $\Phi^y = \frac{1}{2}a(t)(u_y u_x - u u_{xy}),$ $\Phi^z = \frac{1}{2}a(t)(u_z u_x - u u_{xz})$
X_3	$\Phi^t = \frac{1}{2}a(t)^3(-u_y u_t + u u_{ty}), \quad \Phi^x = \frac{1}{2}a(t)(u_y u_x - u u_{xy}),$ $\Phi^y = \frac{1}{2}a(t)(u_y^2 + u(u_{zz} + u_{xx} - a(t)(3a'u_t + a(t)u_{tt}))), \quad \Phi^z = \frac{1}{2}a(t)(u_z u_y - u u_{yz})$

X_4	$\begin{aligned}\Phi^t &= \frac{1}{2}a(t)^3(-u_z u_t + u u_{tz}), \\ \Phi^x &= \frac{1}{2}a(t)(u_z u_x - u u_{xz}), \\ \Phi^y &= \frac{1}{2}a(t)(u_z u_y - u u_{yz}), \\ \Phi^z &= \frac{1}{2}a(t)(u_z^2 + u(u_{yy} + u_{xx} - a(t)(3a'u_t + a(t)u_{tt})))\end{aligned}$
X_5	$\begin{aligned}\Phi^t &= \frac{1}{2}a(t)^3(-x u_y u_t + y u_x u_t + u(x u_{ty} - y u_{tx})), \\ \Phi^x &= \frac{1}{2}a(t)(u_x(x u_y - y u_x) - u(y u_{zz} + u_y + y u_{yy} + x u_{xy} - 3y a(t)a'u_t - y a(t)^2 u_{tt})), \\ \Phi^y &= \frac{1}{2}a(t)(u_y(x u_y - y u_x) + u(x u_{zz} + u_x + y u_{xy} + x u_{xx} - 3x a(t)a'u_t - x a(t)^2 u_{tt})), \\ \Phi^z &= \frac{1}{2}a(t)(u_z(x u_y - y u_x) + u(-x u_{yz} + y u_{xz}))\end{aligned}$
X_6	$\begin{aligned}\Phi^t &= \frac{1}{2}a(t)^3(-x u_z u_t + z u_x u_t + u(x u_{tz} - z u_{tx})), \\ \Phi^x &= \frac{1}{2}a(t)(u_x(x u_z - z u_x) - u(u_z + z u_{zz} + z u_{yy} + x u_{xz} - 3z a(t)a'u_t - z a(t)^2 u_{tt})), \\ \Phi^y &= \frac{1}{2}a(t)(x u_z u_y - z u_y u_x + u(-x u_{yz} + z u_{xy})), \\ \Phi^z &= \frac{1}{2}a(t)(x u_z^2 - z u_z u_x + u(x u_{yy} + u_x + z u_{xz} + x u_{xx} - 3x a(t)a'u_t - x a(t)^2 u_{tt}))\end{aligned}$
X_7	$\begin{aligned}\Phi^t &= \frac{1}{2}a(t)^3(-y u_z u_t + z u_y u_t + u(y u_{tz} - z u_{ty})), \\ \Phi^x &= \frac{1}{2}a(t)(y u_z u_x - z u_y u_x + u(-y u_{xz} + z u_{xy})), \\ \Phi^y &= \frac{1}{2}a(t)(u_y(y u_z - z u_y) - u(u_z + z u_{zz} + y u_{yz} + z u_{xx} - 3z a(t)a'u_t - z a(t)^2 u_{tt})), \\ \Phi^z &= \frac{1}{2}a(t)(y u_z^2 - z u_z u_y + u(u_y + z u_{yz} + y(u_{yy} + u_{xx} - a(t)(3a'u_t + a(t)u_{tt}))))\end{aligned}$

5.3.3 Illustrative reduction and exact solution

We briefly show how the order of the (1+3) equation (61) can be reduced. The equation with four independent variables is reduced to an ordinary differential equation and an exact solution is obtained. See [4] for details.

We begin reducing (61) using X_4 followed by X_5 from (64). That is, in the first case, we obtain the independent invariants of X_4 by solving the first-order linear partial differential equation $X_4 q = 0$, where q is the dependent invariant. By the method

of invariants, the characteristic equations are

$$\frac{dx}{-y} = \frac{dt}{0} = \frac{dy}{x} = \frac{du}{0}.$$

Thus, by integrating the above, we find the invariant $p = \frac{1}{2}(x^2 + y^2)$ so that (61) is reduced to

$$2a(t)(u_p + pu_{pp}) - a^3(t) \left(u_{tt} + \frac{3\dot{a}(t)}{a(t)}u_t \right) = 0 \quad (65)$$

with $u = u(p, t)$.

A Lagrangian of (65) is

$$L = -\frac{a^3(t)}{2}u_t^2 + a(t)pu_p^2.$$

It turns out that a symmetry of (65) for $a(t) = t$ is

$$X_1^* = u\partial_u - t\partial_t.$$

We reduce (65) with $a(t) = t$, using X_1^* and obtain the characteristic equations

$$\frac{du}{u} = \frac{dt}{-t} = \frac{dp}{0}.$$

Integrating yields $\gamma = ut$, and (65) is reduced to the ordinary differential equation

$$2\gamma_p + 2p\gamma_{pp} + \gamma = 0. \quad (66)$$

A solution of (66) is

$$\gamma(p) = \text{BesselJ}[0, \sqrt{2p}] C_1 + 2\text{BesselY}[0, \sqrt{2p}] C_2, \quad (67)$$

where $\text{BesselJ}[n, z]$ is the Bessel function of the first kind $J_n(z)$, $\text{BesselY}[n, z]$ is the Bessel function of the second kind $Y_n(z)$ and C_1, C_2 are arbitrary constants.

5.4 Conclusion

We have discussed the isometries of the FRW metric for different curvatures in their relationship to the Noether symmetries of the geodesic equations. The nonlinear wave and Klein-Gordon equations were constructed and analysed in FRW geometry. The classical method of Noether's theorem was used for the derivation of symmetries and conservation laws of the underlying equations. As an illustration, we performed a symmetry reduction of the wave equation on a FRW manifold and obtained an exact solution.

Chapter 6

Higher-order Symmetries and Conservation Laws

6.1 Introduction

We investigate the existence of higher-order symmetries and conservation laws for the Klein-Gordon equation. We apply the multiplier approach that leads to a large class of interesting and higher-order conserved flows that would not have been obtained by variational techniques such as Noether's theorem. Other multipliers and conserved densities exist for the Gordon-type equations and may be found in [53].

It can be proved that with the well-known transformations,

$$X = \frac{1}{2}(x - t) \quad \text{and} \quad T = \frac{1}{2}(x + t), \quad (68)$$

the (1+1) classical wave equation

$$u_{tt} - u_{xx} - k(u) = 0, \quad (69)$$

can be transformed to the canonical form [4]

$$u_{XT} - k(u) = 0. \quad (70)$$

Equation (70) has been extensively studied in terms of its symmetries and variational properties [4]. In particular, the sine-Gordon equation, $u_{XT} - \sin u = 0$, has been shown to have higher-order variational symmetries giving rise to interesting, nontrivial conservation laws, for example, the symmetries,

$$\begin{aligned} X_1 &= (u_{XXX} + \frac{1}{2}u_X^3)\partial_u, \\ X_2 &= (u_{XXXX} + \frac{5}{2}u_X^2u_{XX} + \frac{5}{2}u_Xu_{XX}^2 + \frac{3}{8}u_X^5)\partial_u, \\ X_3 &= (u_{TTT} + \frac{1}{2}u_T^3)\partial_u, \end{aligned} \quad (71)$$

are variational as they satisfy Theorem 1 [4].

The first two symmetries in (71) lead to the corresponding densities

$$\Phi_1^T = -\frac{1}{2}u_{XX}^2 + \frac{1}{8}u_X^4, \quad \Phi_2^T = \frac{1}{2}u_{XXX}^2 - \frac{5}{4}u_X^2u_{XX}^2 + \frac{1}{16}u_X^6. \quad (72)$$

In a previous paper [53], we investigated the canonical form of the wave equation (70). Using the multiplier method, it was found that the only other cases of (70) that yield derivative dependent symmetries are when $k(u) = u$ and $k(u) = e^u$. The third-order symmetries for (70) are

$$\begin{aligned} k(u) = u & : X_* = (u_{XXX} + ne^{X+T})\partial_u, \text{ } n \text{ is an arbitrary constant,} \\ k(u) = e^u & : X_{**} = (u_{XXX} - \frac{1}{2}u_X^3)\partial_u. \end{aligned} \quad (73)$$

These symmetries can be useful for finding higher-order symmetries and conservation laws for the classical wave equation (69). Once the results of the (1+1) wave equation (69) are known, they may be extended to the multi-dimensional Gordon-type equations. That is, the multi-dimensional Gordon-type equations are best considered as

$$u_{tt} - \Delta u - k(u) = 0, \quad (74)$$

where Δ denotes the Laplacian.

6.2 (1+1) Gordon-type equations

Consider the following special cases of equation (69) in the form

$$(a) \quad u_{xx} - u_{tt} - \sin u = 0$$

$$(b) \quad u_{xx} - u_{tt} - u = 0$$

$$(c) \quad u_{xx} - u_{tt} - e^u = 0$$

In each case, we list one of the higher-order symmetries and conserved densities which arise as a consequence of transforming the results of the canonical forms, (71) and (73). Case (a) is done in detail.

$$(a) \quad u_{xx} - u_{tt} - \sin u = 0$$

In converting from equations (70) to (69), we use the transformations,

$$x = X + T, \quad t = T - X$$

and obtain higher-order symmetries for the classical equation (69), we denote these symmetries by \mathcal{X} . We will now illustrate the method using $X_1 = (u_{XXX} + \frac{1}{2}u_X^3)\partial_u$ from (71). Since,

$$\begin{aligned} u_X &= u_x x_X + u_t t_X \\ &= u_x - u_t, \end{aligned}$$

$$\begin{aligned} u_{XX} &= u_{xx} x_X + u_{xt} t_X - u_{tx} x_X - u_{tt} t_X \\ &= u_{xx} - 2u_{xt} + u_{tt}, \end{aligned}$$

$$\begin{aligned}
u_{XXX} &= u_{xxx}x_X + u_{xxt}t_X - 2(u_{xtx}x_X + u_{xtt}t_X) + u_{ttx}x_X + u_{ttt}t_X \\
&= u_{xxx} - 3u_{xxt} + 3u_{xtt} - u_{ttt},
\end{aligned}$$

we have that the equivalent of X_1 is

$$\mathcal{X}_1 = (u_{xxx} - 3u_{xxt} + 3u_{xtt} - u_{ttt} + \frac{1}{2}(u_x - u_t)^3) \partial_u,$$

where \mathcal{X}_1 is also an evolutionary generator of (69), that leads to the conserved density

$$\begin{aligned}
\Phi_1^t &= \frac{1}{8}(u_t^4 + 4u_{tt}^2 - 3u_t^3u_x + 4u_{ttt}u_x - 4\cos(u)u_x^2 + 8u_{tt}(\sin(u) - u_{xt}) \\
&\quad - 16\sin(u)u_{xt} + 3uu_x^2u_{xt} - 4u_xu_{xtt} + 4uu_{xttt} + u_t^2(-4\cos(u) + 3u_x^2 \\
&\quad + 3u(u_{xt} - u_{xx})) + 8\sin(u)u_{xx} - 3uu_x^2u_{xx} + 8u_{xt}u_{xx} - 4u_{xx}^2 \\
&\quad - 4u_xu_{xxt} - 12uu_{xxtt} + 4u_xu_{xxx} + u_t(-u_x^3 + u_x(8\cos(u) \\
&\quad - 6u(u_{xt} - u_{xx})) - 8(u_{xtt} - 2u_{xxt} + u_{xxx})) + 12uu_{xxx} - 4uu_{xxxx}).
\end{aligned}$$

$$(b) \quad u_{xx} - u_{tt} - u = 0$$

$$\mathcal{X}_2 = (u_{xxx} - u_{ttt} - 3u_{txx} + 3u_{ttx} + e^x)\partial_u,$$

where \mathcal{X}_2 corresponds to X_* in (73) with $n = 1$. The corresponding conserved density for \mathcal{X}_2 is

$$\begin{aligned}
\Phi_2^t &= \frac{1}{2}(-u_t^2 + u_{tt}^2 + u_{ttt}u_x - u_x^2 - 2u_{tt}u_{xt} - u_xu_{xtt} + 2u_{xt}u_{xx} - u_{xx}^2 \\
&\quad - u_xu_{xxt} + u_xu_{xxx} - 2u_t(e^x - u_x + u_{xtt} - 2u_{xxt} + u_{xxx}) + u(2u_{tt} - 4u_{xt} \\
&\quad + u_{xttt} + 2u_{xx} - 3u_{xxtt} + 3u_{xxx} - u_{xxxx})).
\end{aligned}$$

$$(c) \quad u_{xx} - u_{tt} - e^u = 0$$

$$\mathcal{X}_3 = (u_{xxx} - u_{ttt} - 3u_{txx} + 3u_{ttx} - \frac{1}{2}(u_x - u_t)^3)\partial_u,$$

where \mathcal{X}_3 corresponds to X_{**} in (73). The corresponding conserved density for X_3 is

$$\begin{aligned}\Phi_3^t = & \frac{1}{8}(-u_t^4 + 4u_{tt}^2 + 3u_t^3u_x + 4u_{ttt}u_x - 4e^u u_x^2 + 8u_{tt}(e^u - u_{xt}) \\ & - 16e^u u_{xt} - 3uu_x^2 u_{xt} - 4u_x u_{xtt} + 4uu_{xtt} - u_t^2(4e^u + 3u_x^2 \\ & + 3u(u_{xt} - u_{xx})) + 8e^u u_{xx} + 3uu_x^2 u_{xx} + 8u_{xt}u_{xx} - 4u_{xx}^2 - 4u_x u_{xxt} \\ & - 12uu_{xxt} + 4u_x u_{xxx} + u_t(u_x^3 + u_x(8e^u + 6u(u_{xt} - u_{xx}))) \\ & - 8(u_{xtt} - 2u_{xxt} + u_{xxx})) + 12uu_{xxt} - 4uu_{xxx}).\end{aligned}$$

6.3 (1+2) Klein-Gordon equation

We now consider the (1+2) Klein-Gordon equation,

$$u_{xx} + u_{yy} - u_{tt} - u = 0. \quad (75)$$

In the discussion that follows, we first extrapolate a symmetry of equation (75), and secondly we take a formal approach (the multiplier method) for finding symmetries.

Using \mathcal{X}_2 from (b) above, we construct a symmetry of equation (75), namely

$$\mathcal{X}_A = (u_{xxx} + u_{yyy} - u_{ttt} - 3u_{txx} - 3u_{tyy} + 3u_{ttx} + 3u_{tty} + e^x + e^y) \partial_u$$

and we obtain the corresponding conserved density,

$$\begin{aligned}\Phi_A^t = & \frac{1}{2}(-u_t^2 + u_{tt}^2 + u_{ttt}u_y - u_y^2 - 2u_{tt}u_{yt} - u_y u_{ytt} + 2u_{yt}u_{yy} - u_{yy}^2 - u_y u_{yyt} + u_y u_{yyy} + \\ & u_{ttt}u_x - u_{yyt}u_x - u_x^2 - 2u_{tt}u_{xt} + 2u_{yy}u_{xt} - u_x u_{xtt} + u_x u_{xyy} + 2u_{yt}u_{xx} - 2u_{yy}u_{xx} + 2u_{xt}u_{xx} - \\ & u_{xx}^2 - u_y u_{xxt} - u_x u_{xxt} + u_y u_{xxy} + u_x u_{xxx} - u_t(2e^x + 2e^y - 2u_y + 2u_{ytt} - 4u_{yyt} + 2u_{yyy} - \\ & 2u_x + 2u_{xtt} + u_{xyy} - 4u_{xxt} + u_{xxy} + 2u_{xxx}) + u(2u_{tt} - 4u_{yt} + u_{ytt} + 2u_{yy} - 3u_{yyt} + \\ & 3u_{yyy} - u_{yyyy} - 4u_{xt} + u_{xtt} + 2u_{xyt} + 2u_{xx} - 3u_{xxt} + 2u_{xxy} - 2u_{xxy} + 3u_{xxt} - u_{xxx})).\end{aligned}$$

More formally, we employ the multiplier approach. Suppose

$$\frac{\delta}{\delta u} [\mathcal{Q}(u_{xx} + u_{yy} - u_{tt} - u)] = 0, \quad (76)$$

where $\mathcal{Q} = \mathcal{Q}(x, y, t, u_x, u_x, u_{xx}, u_{xy}, u_{xxx}, u_{xxy}, u_{xyy}, u_{yyy})$. Although not pursued here, the calculations may include derivatives of u with respect to t . Then

$$\mathcal{Q}[(u_{xx} + u_{yy} - u_{tt} - u)] = D_t \Phi^t + D_x \Phi^x + D_y \Phi^y,$$

where Φ^x, Φ^y are the conserved fluxes and Φ^t is the conserved density.

We obtain,

$$\begin{aligned} \mathcal{Q} = & \frac{1}{6} \left\{ -3 \left(-\frac{1}{3} u_{yyy} C_4 x^3 + (u_{xy} C_4 + u_{xyy} y C_4 + u_{xyy} C_3 + u_{yyy} C_1) x^2 + (-u_{xxy} y^2 C_4 \right. \right. \\ & + ((-u_{xx} + u_{yy}) C_4 - 2C_1 u_{xyy} - 2u_{xxy} C_3) y - 4u_{xyy} C_5 - 2u_{xy} C_1 + (-u_{xx} \\ & + u_{yy}) C_3 - 2u_{xxy} C_6 + (-2C_6 + 2C_2) u_{yyy} - 2u_y C_{11} \Big) x + \frac{1}{3} u_{xxx} y^3 C_4 + (u_{xxy} C_1 \\ & - u_x C_4 + u_{xxx} C_3) y^2 + ((2C_6 - 2C_2) u_{xyy} + (u_{xx} - u_{yy}) C_1 - 2u_{xy} C_3 + 4u_{xxy} C_5 \\ & + 2u_{xxx} C_6 + 2C_{11} u_x) y - 2u_{xyy} C_8 - 2u_{xxy} C_7 - 2u_{yx} C_2 - 2u_{yyy} C_{10} \\ & \left. \left. + (-2u_{yy} + 2u_{xx}) C_5 - 2u_x C_{13} - 2u_y C_{12} - 2u_{xxx} C_9 \right\} \right. \end{aligned} \quad (77)$$

where the C_i ($i = 1, 2, 3, \dots, 13$) are arbitrary constants. Using (77), we obtain the set of multipliers \mathcal{Q}_i below. We have also listed the corresponding conserved densities Φ_i^t .

$$\begin{aligned} \mathcal{Q}_1 &= u_x, \\ \Phi_1^t &= \frac{1}{2} (-u_t u_x + u u_{xt}), \end{aligned}$$

$$\begin{aligned} \mathcal{Q}_2 &= u_y, \\ \Phi_2^t &= \frac{1}{2} (-u_t u_y + u u_{yt}), \end{aligned}$$

$$\begin{aligned} \mathcal{Q}_3 &= x u_y - y u_x, \\ \Phi_3^t &= \frac{1}{2} (u_t (-x u_y + y u_x) + u (x u_{yt} - y u_{xt})), \end{aligned}$$

$$\begin{aligned} \mathcal{Q}_4 &= u_{xxx}, \\ \Phi_4^t &= \frac{1}{2} (-u_t u_{xxx} + u u_{xxx t}), \end{aligned}$$

$$\mathcal{Q}_5 = u_{yyy},$$

$$\Phi_5^t = \frac{1}{2}(-u_t u_{yyy} + u u_{yyyt}),$$

$$\mathcal{Q}_6 = u_{xyy},$$

$$\Phi_6^t = \frac{1}{2}(-u_t u_{xyy} + u u_{xyyt}),$$

$$\mathcal{Q}_7 = u_{xxy},$$

$$\Phi_7^t = \frac{1}{2}(-u_t u_{xxy} + u u_{xxyt}),$$

$$\mathcal{Q}_8 = -u_{yx} + x u_{yyy} - y u_{xyy},$$

$$\Phi_8^t = \frac{1}{2}(u_t(-x u_{yyy} + u_{xy} + y u_{xyy}) + u(x u_{yyyt} - u_{xyt} - y u_{xyyt})),$$

$$\mathcal{Q}_9 = u_{xx} - 2x u_{xyy} + 2y u_{xxy} - u_{yy},$$

$$\Phi_9^t = \frac{1}{2}(u_t(u_{yy} + 2x u_{xyy} - u_{xx} - 2y u_{xxy}) + u(-u_{yyt} - 2x u_{xyyt} + u_{xxt} + 2y u_{xxyt})),$$

$$\mathcal{Q}_{10} = -x u_{xxy} - x u_{yyy} + y u_{xyy} + y u_{xxx},$$

$$\Phi_{10}^t = \frac{1}{2}(u_t(x u_{yyy} - y u_{xyy} + x u_{xxy} - y u_{xxx}) + u(-x u_{yyyt} + y u_{xyyt} - x u_{xxyt} + y u_{xxxxt})),$$

$$\mathcal{Q}_{11} = -x u_{xx} + x^2 u_{xyy} + x u_{yy} + y^2 u_{xxx} - 2xy u_{yxx} - 2y u_{xy},$$

$$\Phi_{11}^t = \frac{1}{2}(-u_t(x u_{yy} - 2y u_{xy} + x^2 u_{xyy} - x u_{xx} - 2xy u_{xxy} + y^2 u_{xxx}) + u(x u_{yyt} - 2y u_{xyt} + x^2 u_{xyyt} - x u_{xxt} - 2xy u_{xxyt} + y^2 u_{xxxxt})),$$

$$\mathcal{Q}_{12} = y u_{xx} + x^2 u_{yyy} - y u_{yy} + y^2 u_{yxx} - 2xy u_{yyx} - 2x u_{xy},$$

$$\Phi_{12}^t = \frac{1}{2}(-u_t(-y u_{yy} + x^2 u_{yyy} - 2x u_{xy} - 2xy u_{xyy} + y u_{xx} + y^2 u_{xxy}) + u(-y u_{yyt} + x^2 u_{yyyt} - 2x u_{xyt} - 2xy u_{xyyt} + y u_{xxt} + y^2 u_{xxyt})),$$

$$\begin{aligned}
\mathcal{Q}_{13} &= -xyu_{xx} - \frac{1}{3}x^3u_{yyy} + \frac{1}{3}y^3u_{xxx} + xyu_{yy} - y^2u_{xy} - xy^2u_{xxy} + yx^2u_{xyy} \\
&\quad + x^2u_{xy}, \\
\Phi_{13}^t &= \frac{1}{6}(u_t(-3xyu_{yy} + x^3u_{yyy} - 3x^2u_{xy} + 3y^2u_{xy} - 3x^2yu_{xxy} + 3xyu_{xx} \\
&\quad + 3xy^2u_{xxy} - y^3u_{xxx}) + u(3xyu_{yyt} - x^3u_{yyyt} + 3x^2u_{xyt} - 3y^2u_{xyt} \\
&\quad + 3x^2yu_{xxyt} - 3xyu_{xxt} - 3xy^2u_{xxyt} + y^3u_{xxxxt})).
\end{aligned}$$

The evolutionary, higher-order multipliers $\mathcal{X}_i = \mathcal{Q}_i \partial_u$ are variational. One may prove this with the use of Theorem 1. For example,

$$\begin{aligned}
\mathcal{X}E + \mathcal{A}\mathcal{F}_{\mathcal{Q}_8}E &= Q^{xx} + Q^{yy} - Q^{tt} - Q \\
&\quad + (D_{xy} + yD_{xyy} - xD_{yyy})(u_{xx} + u_{yy} - u_{tt} - u) \\
&= u_{xxxy} + u_{xyyy} - u_{xytt} - u_{xy} + y(u_{xxxyy} + u_{xyyyy} - u_{ttxyy} \\
&\quad - u_{xyy}) - x(u_{xxyyy} + u_{yyyyy} - u_{ttyyy} - u_{yyy}) + 2u_{xyyy} \\
&\quad + xu_{xxyyy} - yu_{xxxyy} - u_{xxxy} + u_{yyyyy} - 2u_{xyyy} - yu_{xyyyy} \\
&\quad - u_{xyyy} - xu_{yytyt} + yu_{xytyt} + u_{xytt} - xu_{yyy} + yu_{xyy} + u_{xy} \\
&= 0.
\end{aligned}$$

After some lengthy calculations, it appears that for the multi-dimensional Gordon-type equations (74), *higher-order* symmetries/multipliers (and the corresponding conserved quantities) may be determined for the case $k(u) = u$ only. The underlying calculations for the cases $k(u) = \sin(u)$ and $k(u) = e^u$ produce negative results despite spending a huge amount of time on it. This seems to be a consequence of the underlying differential operator being linear only if $k(u) = u$ (see Proposition 1).

6.4 Conclusion

In the first of our analysis of the classical Gordon-type equations, we utilized results based on higher-order symmetries of the equations in canonical form. We established interesting results of higher-order symmetries and conserved flows for the (1+1) classical equations. We studied the (1+2) Klein-Gordon equation to determine possible higher-order symmetries. The higher-order symmetries were deduced by extrapolating the results of the (1+1) Klein-Gordon equation and, more formally, using the multiplier approach. In applying the multiplier approach to the Klein-Gordon equation, we determined a large set of thirteen higher-order symmetries and conserved densities, which would not have been obtained with variational techniques such as Noether's theorem.

Conclusion

Symmetry analysis is a special tool used to understand and construct solutions of differential equations. The existence of infinitely many generalized symmetries is of great significance, especially in situations of physical and mathematical interest, where symmetries are used to reduce the number of unknown functions. Therefore, understanding the symmetry structure of spacetimes in any dimension is important. Numerous studies have also been dedicated to finding the conservation laws for given differential equations. Conservation laws play a significant role in the solution process of differential equations. In this study, we identified numerous symmetries and conserved flows of some nonlinear wave equations.

We constructed the wave equation in several spacetime geometries, bearing in mind that the four dimensional wave equation may be of more physical significance. For this purpose, we implemented the covariant d'Alembertian operator. The constructed wave equation naturally inherited some nonlinearity on the geometries and was cumbersome and tedious to solve. We began our study by analyzing wave and Klein-Gordon equations on spacetimes such as: de Sitter, Milne, Bianchi III and FRW.

Wave and Klein-Gordon equations in de Sitter spacetimes proved to be interesting

from the symmetry point of view. Using the Lie symmetry generators (one parameter Lie groups of transformations), we classified and reduced the underlying equations, leading to the derivation of conserved quantities. The equations were studied using some special potential functions and with restrictions on the mass parameters. It is well-known that the (1+3) linear wave equation admits a 16-dimensional Lie algebra of symmetries (excluding the infinite symmetry) on flat spacetime. Comparatively, we discovered that the Lie algebra of the wave equation with zero potential on de Sitter spacetime is 11-dimensional. In the cases discussed, we found ‘twelve’ or ‘eighteen’ dimensional Lie symmetry groups. Interestingly, all the symmetry groups contained a ‘six’ dimensional Lie symmetry subgroup. As such these symmetries form a subgroup of the Killing group admitted by the de Sitter spacetime.

We investigated a class of wave and Gordon-type equations on the Milne metric. In particular, we conducted a Lie and Noether symmetry analysis of a Klein-Gordon equation on this manifold and calculated the conserved densities. In an effort to obtain higher-order symmetries, we exploited multiplier methods for the Klein-Gordon equation. This method was successful for the projected equation. The wave equation on the Bianchi III manifold provided some interesting symmetries. We classified the symmetry generators based on some parameters of the line element and then obtained the associated conserved forms.

In studying the FRW manifold, we first took a brief look at the isometries of the FRW metric for different curvatures. The nonlinear wave and Klein-Gordon equations were constructed and the Noether symmetries were determined. In applying the classical Noether’s theorem, the conserved forms of the wave equation were derived. In the final chapter, we employed the multiplier approach on lower dimensional Gordon-type equations. We found that the multipliers led to a large class of interesting and higher-order symmetries and conserved flows that would not be

obtained by variational techniques such as Noether's theorem. Calculations of the (1+1) equations were extrapolated to obtain results for the (1+2) equation. The extrapolation may be useful if applied to higher dimensional equations.

We have performed detailed symmetry reductions of the wave equation on the spacetimes under investigation in order to obtain exact or invariant solutions. In general, the procedure performed, i.e., the method of invariants, is the most convenient. Not all of the symmetries provided here lead to physical conservation laws. However, these are as useful in application - mainly to reduce the underlying differential equation. We hope that solving the nonlinear wave equation in curved spacetime provides some insight into the geometry or relativity of different manifolds.

Bibliography

- [1] I. Newton, “*The Mathematical Works*,” D.T. Whiteside, Johnson Reprint Corp., 1964.
- [2] V.I. Arnold, “*Mathematical Methods of Classical Mechanics*,” 2nd ed., Sringer-Verlag, New York, 1989.
- [3] S. Anco and G. Bluman, “Direct Construction Method for Conservation Laws of Partial Differential Equations Part I: Examples of conservation law classifications,” *European J. of Appl. Maths.*, vol. 13, pp. 545, 2002.
- [4] P. Olver, “*Application of Lie Groups to Differential Equations*,” Springer, New York, 1993.
- [5] L. V. Ovsiannikov, “*Group analysis of differential equations*,” Academic Press, New York, 1982.
- [6] N.H. Ibragimov, “*CRC Handbook of Lie group analysis of differential equations: Symmetries, exact solutions and conservation laws*,” vol. 1, Boca Raton, CRC Press Inc., 1994.
- [7] N.H. Ibragimov, “*Elementary Lie Group Analysis and Ordinary Differential Equations*,” John Wiley & Sons, Chichester, 1999.

- [8] E. Noether, “Invariante Variationsprobleme,” *Nachrichten der Akademie der Wissenschaften in Göttingen, Mathematisch-Physikalische Klasse*, vol. 2, pp. 235, 1918 (English translation in “*Transport Theory and Statistical Phys.*,” vol. 1(3), pp. 186, 1971).
- [9] A. H. Bokhari and A. H. Kara, “Noether versus Killing symmetry of conformally flat Friedmann metric,” *Gen. Relativ. Gravit.*, vol. 39, pp. 2053, 2007.
- [10] A. H. Bokhari, A. H. Kara, A. R. Kashif and F. D. Zaman, “Noether Symmetries Versus Killing Vectors and Isometries of Spacetimes,” *Int. J. Th. Phys.*, vol. 45(6), pp. 1029, 2006.
- [11] N. Byers, “E. Noether’s discovery of the deep connection between symmetries and conservation laws,” Physics/9807044.
- [12] G. Compère, “*Symmetries and conservation laws in Lagrangian gauge theories with applications to the Mechanics of black holes and to Gravity in three dimensions*,” University of Bruxelles, 2007.
- [13] C.W. Misner, K. S. Thorne and J. A. Wheeler, “*Gravitation*,” W. H. Freeman, San Francisco, 1973.
- [14] K. Yagdjian and A. Galstian, “Fundamental Solutions for the Klein-Gordon Equation in de Sitter Spacetime,” *Comm. in Math. Phys.*, vol. 285, pp. 293, 2009.
- [15] S. Jamal, A.H. Kara and A.H. Bokhari, “Symmetries, conservation laws, reductions and exact solutions for the Klein-Gordon equation in de Sitter spacetimes,” *Canadian J. of Phys.*, vol. 90(7), pp. 667, 2012.
- [16] S. Jamal, A.H. Kara, F.D. Zaman and A.H. Bokhari, “The symmetries and conservation laws of some Gordon-type equations in Milne spacetime,” *Pramana J. of Phys.*, P - 9682, 2012.

- [17] S. Jamal, A.H. Kara and A.H. Bokhari, “Symmetries, conservation laws and reduction of wave and Gordon-type equations on Riemannian manifolds,” *Proc. of the WASET International Conference on Applied Mathematics and Engineering*, Phuket, vol. 60, pp. 945, 2011.
- [18] S. Jamal, A. H. Kara and R. Narain, “Wave equations in Bianchi spacetimes,” *J. of Applied Math.*, 2012. doi:10.1155/2012/765361
- [19] U. Camci, S. Jamal and A. H. Kara, “Invariances and conservation laws based on some Friedmann-Robertson-Walker manifolds,” *General Relativity and Gravitation*, 2013.
- [20] S. Jamal and A. H. Kara, “Higher-order symmetries and conservation laws of multi-dimensional Gordon-type equations,” *Pramana J. of Phys.*, vol. 77 (3), pp. 447, 2011.
- [21] E. Bessel-Hagen, “Über die Erhaltungssätze der Elektrodynamik,” *Math. Ann.* vol. 84, pp. 258, 1921.
- [22] H. Goldstine, “*A History of the Calculus of Variations from the 17th through 19th Century*, *Studies in the History of Mathematical and Physical Sciences*,” vol. 5, Springer-Verlag, New York, 1980.
- [23] I. M. Anderson and T. E. Duchamp, “Variational principles for second order quasi-linear scalar equations,” *J. Differential Equations*, vol. 51, pp. 1, 1984.
- [24] N. H. Ibragimov, “*Transformation Groups Applied to Mathematical Physics*,” Reidel, Dordrecht, Netherlands, 1985.
- [25] G. Bluman and S. Kumei, “*Symmetries and Differential Equations*,” Springer-Verlag, New York, 1989.

- [26] N. H. Ibragimov, A. H. Kara and F. M. Mahomed, “Lie-Bäcklund and Noether Symmetries with applications,” *Nonlinear Dynamics*, vol. 15, pp. 115, 1998.
- [27] H. Steudel, “Über die Zuordnung zwischen Invarianzeigenschaften und Erhaltungssätzen,” *Zeit. Naturforsch.*, vol. 17A, pp. 129, 1962.
- [28] U. Göktas and W. Hereman, “Computation of Conservation Laws for Nonlinear Lattices,” *Physica D*, vol. 123, pp. 425, 1998.
- [29] W. Hereman, M. Colagrosso, R. Sayers, A. Ringler, B. Deconinck, M. Nivala and M. S. Hickman, “*In Differential Equations with Symbolic Computation*,” Birkhäuser Verlag, Basel, 2005.
- [30] W. Hereman, “Symbolic Computation of Conservation Laws of Nonlinear Partial Differential Equations in Multi-Dimensions,” *Int. J. of Quantum Chem.*, vol. 106, pp. 278, 2006.
- [31] A. H. Kara and F. M. Mahomed, “Relationship between Symmetries and Conservation Laws,” *Int. J. Th. Phys.*, vol. 39(1), pp. 23, 2000.
- [32] A. H. Kara and F. M. Mahomed, “A Basis of Conservation Laws for Partial Differential Equations,” *J. Nonlinear Math. Phys.*, vol. 9, pp. 60, 2002.
- [33] A.H. Kara and F.M. Mahomed, “Noether-type symmetries and conservation laws via partial Lagrangians,” *Nonlinear Dynamics*, vol. 45, pp. 367, 2006.
- [34] N.H. Ibragimov, A. H. Kara, and F. M. Mahomed, “Relationship between symmetries and conservation laws,” *Nonlinear Dynamics*, vol. 15(2), pp. 115, 1998.
- [35] I. M. Anderson and T. E. Duchamp, “On the existence of global variational principles,” *Am. J. Math*, vol. 102, pp. 781, 1980.
- [36] H. Stephani, “*General Relativity - An introduction to the theory of the gravitational field*,” 2nd ed., Cambridge University Press, Cambridge, 1990.

- [37] H. V. Peiris, “*Cosmology Part I: The Unperturbed Universe*,” Institute of Astronomy, University of Cambridge, Cambridge.
- [38] M. Dafermos and I. Rodnianski, “*The wave equation on Schwarzschild-de Sitter spacetimes*,” ArXiv.0709.2766, 2008.
- [39] A.H. Bokhari, A.Y. Al-Dweik, A.H. Kara, M.Karim, and F.D. Zaman, “Wave equation on spherically symmetric Lorentzian metrics,” *J. of Math. Phys.*, vol. 52 (6), 2011.
- [40] J.F. Bony and D. Hafner, “Decay and non-decay of the local energy for the wave equation in the de Sitter-Schwarzschild metric,” *Comm. Math. Phys.*, vol. 282(3), pp. 697, 2008.
- [41] K. Yagdijian and A. Galstian, “Fundamental solutions for wave equation in Robertson-Walker model of universe and $L^p - L^q$ -Decay Estimates,” *Discrete and Continuous Dynamical Systems S*, vol. 2(3), pp. 483, 2009.
- [42] N.D. Birrell and P.C.W. Davies, “*Quantum fields in curved space*,” Cambridge, New York, Cambridge University Press, 1984.
- [43] C. Møller, “*The theory of relativity*,” Oxford, Clarendon Press, 1952.
- [44] A.D. Rendall, “Applications of the theory of evolution equations to general relativity,” *General Relativity - Proc. of the 16th International Conference*, Eds.: N T Bishop and S D Maharaj, World Scientific, Singapore, 2002.
- [45] A. Mahdi Mugbil, “*PhD Thesis: On Noether symmetries and conservation laws*,” King Fahd University of Petroleum and Minerals, Dhahran, Saudi Arabia, 2011.
- [46] S. Capozziello, G. Marmo, C. Rubano, P. Scudellaro, “Noether symmetries in Bianchi universes,” *Int. J. Mod. Phys. D*, vol. 6, pp. 491, 1997.

- [47] U. Camci and Y. Kucukakca, “Noether gauge symmetry for $f(R)$ gravity in Palatini formalism,” *Phys. Rev. D*, vol. 76, 2007.
- [48] A.K. Sanyal, “Bianchi Type I Cosmology in Generalized Saez-Ballester Theory via Noether Gauge Symmetry,” *Phys. Lett. B*, pp. 177, 2002.
- [49] D. S. Gomez, “*On Friedmann-Lemaître-Robertson-Walker cosmologies in non-standard gravity*,” University of Barcelona, 2011.
- [50] A. Friedman, “On the Curvature of Space,” *General Relativity and Gravitation*, vol. 31(12), 1999.
- [51] S. Capozziello, A. Stabile and A. Troisi, “Spherically symmetric solutions in $f(R)$ gravity via the Noether symmetry approach,” *Class. Quantum Grav.*, vol. 24, 2007.
- [52] I. Hussain, M. Jamil and F. M Mahomed, “Noether gauge symmetry approach in $f(R)$ gravity,” *Astrophys. Space Sci.*, 2011.
- [53] S. Jamal and A. H. Kara, “New higher-order conservation laws of some classes of wave and Gordon-type equations,” *Nonlinear Dynamics*, vol. 67, pp. 97, 2010.